





ISO 9001 CERTIFIED

607 NW 27th Ave  
Ocala, FL 34475  
Phone: (352) 629-5020 or 800-533-3569  
Fax: (352)-629-2902

## OPERATION MANUAL

**ES-Key**  
**8 PDM module (4 selectable polarity outputs)**  
**with 4 Inputs (selectable polarity)**  
P/N 610-00034





  607 NW 27th Ave Ocala, FL 34475 Phone : (352) 629-5020 Fax : (352)-629-2902	FOR EXTERNAL DISTRIBUTION			PAGE	1 of 18
	<b>OPERATION MANUAL</b>			DATE	1/22/2015
PRODUCT GROUP	ES-Key	P/N	FSG-MNL-00110	REV	1.00
PRODUCT	8 PDM module with Inputs			BY	GMC

<b>1.</b>	<b>REVISION LOG .....</b>	<b>1</b>
<b>2.</b>	<b>MODULE OVERVIEW .....</b>	<b>2</b>
2.1.	SCOPE .....	2
2.2.	PART NUMBERS.....	2
2.3.	DEFAULT CONFIGURATION SETUP.....	2
<b>3.</b>	<b>MODULE OPERATION .....</b>	<b>3</b>
3.1.	SELECTABLE POLARITY INPUTS .....	3
3.1.1.	<i>Input polarity selection.....</i>	4
3.2.	SOLID STATE OUTPUTS .....	5
3.2.1.	<i>Flash outputs .....</i>	5
3.2.2.	<i>Pulse Width Modulate (PWM) outputs .....</i>	6
3.2.3.	<i>Output polarity selection.....</i>	7
3.3.	MODULE TYPE AND ADDRESS.....	8
3.3.1.	<i>Device type selection.....</i>	8
3.4.	INPUT/OUTPUT MEMORY SPACE.....	9
<b>4.</b>	<b>CONNECTOR DESCRIPTION.....</b>	<b>10</b>
4.1.	CONNECTOR PINOUT .....	10
4.1.1.	<i>Terminating resistor requirement (CAN communication).....</i>	11
4.2.	SYSTEM COMPATIBILITY .....	11
<b>5.</b>	<b>LEGACY PART NUMBER COMPATIBILITY CHART .....</b>	<b>12</b>
5.1.	LEGACY COMPATABILITY .....	12
5.1.1.	<i>104434.....</i>	12
5.1.2.	<i>104528.....</i>	13
5.1.3.	<i>104529.....</i>	14
5.1.4.	<i>105071.....</i>	15
<b>6.</b>	<b>MOUNTING .....</b>	<b>16</b>
6.1.	MOUNTING DIMENSIONS.....	16
6.2.	MOUNTING NOTES.....	16
<b>7.</b>	<b>DIAGNOSTICS .....</b>	<b>17</b>
<b>8.</b>	<b>GLOSSARY .....</b>	<b>18</b>
<b>9.</b>	<b>TECHNICAL DETAILS .....</b>	<b>18</b>
9.1.	WEEE (WASTE OF ELECTRICAL AND ELECTRONIC EQUIPMENT) DIRECTIVE.....	18

## 1. Revision Log

Rev	Date	Approved	Changes
1.00	2-02-2015	GMC	Initial requirements

  607 NW 27th Ave Ocala, FL 34475 Phone : (352) 629-5020 Fax : (352)-629-2902	FOR EXTERNAL DISTRIBUTION			PAGE	2 of 18	
	<b>OPERATION MANUAL</b>			DATE	1/22/2015	
	PRODUCT GROUP	ES-Key	P/N	FSG-MNL-00110	REV	1.00
	PRODUCT	8 PDM module with Inputs			BY	GMC

## 2. Module Overview

### 2.1. Scope

The Power Distribution Module (PDM) is an ES-Key™ node designed to allow a designer the ability to utilize the product within the ES-Key™ electrical system network. The module responds to commands to activate its physical outputs and reports the state of its inputs back to the network. The module has 8 outputs of which 4 of the outputs can be polarity selectable or configured as polarity selectable inputs.

### 2.2. Part numbers

8 PDM With Inputs                      Hale – p/n                      610-00034

### 2.3. Default Configuration Setup

The default module configuration when the part is delivered will be set for 8 positive outputs set to a device ID of 1 see Table 1 and Table 2.

Function	Mode	Position	Function	Mode	Position
IN 0 OUT 7	OUTPUT	UP	POL IN0	NEG	UP
		UP	POL IN1	NEG	UP
IN 1 OUT 6	OUTPUT	UP	POL IN2	NEG	UP
		UP	POL IN3	NEG	UP
IN 2 OUT 5	OUTPUT	UP	DEVICE	TYPE 1	DOWN
		UP	AUX	N/A	UP
IN 3 OUT 4	OUTPUT	UP	AUX	N/A	UP
		UP	AUX	N/A	UP

Table 1. Default Dip Switch Settings.

(Note: The top row of dip switches must be selected in pairs).

(Note: The shunt jumpers must be selected in pairs).

4		5		6		7	
H2	H3	H4	H5	H6	H7	H8	H9
Pos 1	Pos 1	Pos 1	Pos 1	Pos 1	Pos 1	Pos 1	Pos 1
POSITIVE		POSITIVE		POSITIVE		POSITIVE	

Table 2. Default Shunt Settings

(Note: Selection switches are only read on power up).

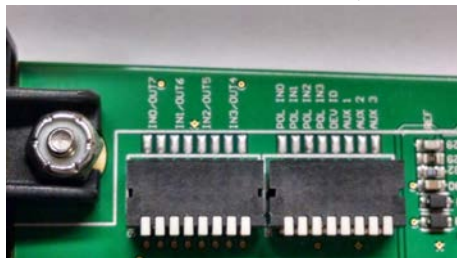



Figure 1. Dip Switch selection switches



Figure 2. Output polarity shunts

 607 NW 27th Ave Ocala, FL 34475 Phone : (352) 629-5020 Fax : (352)-629-2902	FOR EXTERNAL DISTRIBUTION			PAGE	3 of 18
	<b>OPERATION MANUAL</b>			DATE	1/22/2015
PRODUCT GROUP	ES-Key	P/N	FSG-MNL-00110	REV	1.00
PRODUCT	8 PDM module with Inputs			BY	GMC

### 3. Module Operation

#### 3.1. Selectable polarity inputs

The module has digital inputs that can be configured for either positive or ground input (see section 3.1.1). An input is flagged as ACTIVE in the ES-Key database when the voltage level of the input is within the required range (refer to the table below). (refer to the table below).

Input Polarity	Input requirement
Positive	Input is flagged as ACTIVE when its voltage is greater than 60% of supply power.
Ground	Input is flagged as ACTIVE when its voltage is less than 40% of supply power.

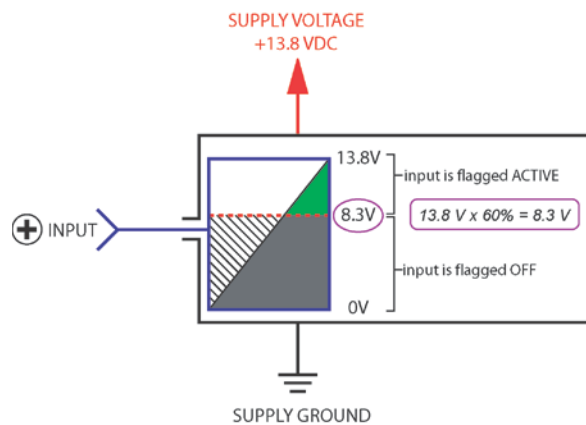

Figure 3. *Positive input example.*

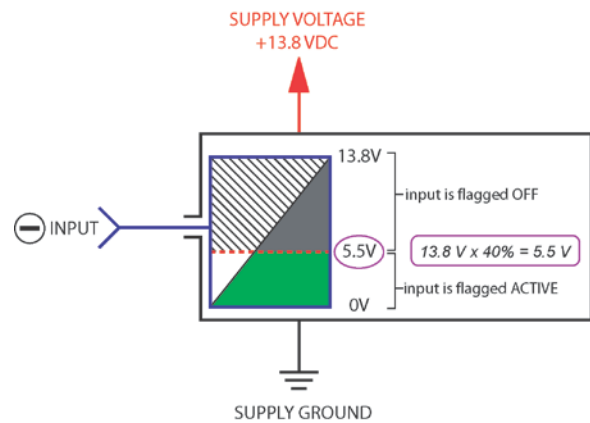



Figure 4. *Ground input example.*

The examples above illustrate the voltage range required for an input to be flagged as ACTIVE to the ES-Key database. The voltage range is based on the polarity of the input (positive or ground) and the voltage level of the supply voltage. In figure 1 the input is a positive polarity type, the supply voltage is 13.8 VDC, and the valid voltage range for the input is 8.3 VDC and greater (less than 8.3 VDC flags the input as OFF).

  607 NW 27th Ave Ocala, FL 34475 Phone : (352) 629-5020 Fax : (352)-629-2902	<b>FOR EXTERNAL DISTRIBUTION</b>			<b>PAGE</b>	4 of 18	
	<b>OPERATION MANUAL</b>			<b>DATE</b>	1/22/2015	
	<b>PRODUCT GROUP</b>	ES-Key	<b>P/N</b>	FSG-MNL-00110	<b>REV</b>	1.00
	<b>PRODUCT</b>	8 PDM module with Inputs			<b>BY</b>	GMC

### 3.1.1. Input polarity selection

The polarity of each input is selected by setting the input/output and polarity dip switches (located inside of the case) to the desired positions. Table 3 shows the settings to select the input configurations of inputs 0 - 3.

INPUT	DIP SWITCH	DIP SWITCH	DIP SWITCH	
			POS	DOWN
0	IN0/OUT7	DOWN	POL IN0	DOWN
			NEG	UP
1	IN1/OUT6	DOWN	POL IN1	DOWN
			NEG	UP
2	IN2/OUT5	DOWN	POL IN2	DOWN
			NEG	UP
3	IN3/OUT4	DOWN	POL IN3	DOWN
			NEG	UP

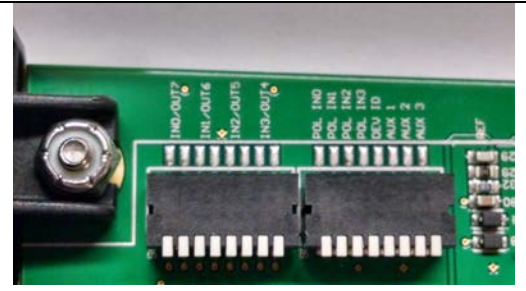



Figure 5 Dip Switch selection switches.

Table 4. Default Dip Switch Settings.

(Note: Selection switches are only read at power up).

  607 NW 27th Ave Ocala, FL 34475 Phone : (352) 629-5020 Fax : (352)-629-2902	FOR EXTERNAL DISTRIBUTION			PAGE	5 of 18	
	<b>OPERATION MANUAL</b>			DATE	1/22/2015	
	PRODUCT GROUP	ES-Key	P/N	FSG-MNL-00110	REV	1.00
	PRODUCT	8 PDM module with Inputs			BY	GMC

### 3.2. Solid State Outputs

Each output of the PDM utilizes solid state, fully protected high-side drivers that feature overload protection, current limitation, open load detection and transient protection. These output drivers replace the requirement of a relay and circuit breaker. The module also has 4 low-side drivers that feature overload protection and transient protection (see section 3.2.3 for polarity selection).

*High Current Rating.* Each of the high current outputs is capable of supplying 7.5 Amps continuously on all outputs at 85° Celsius.

*Low Current Rating.* Each of the low current outputs is capable of supplying .25 Amps continuously on all outputs at 85° Celsius.

*Circuit Protection/Breaker.* If output current exceeds 8 Amps nominal the output will automatically turn off. The module will attempt to connect the output to the load two more times at 5 second intervals. If the output is still overloaded, then it will remain off.

The "circuit breaker" feature can be reset (or reinitialized) by de-activating the output through the ES-Key™ network - in the distributed network, any number of switches may be configured to deactivate the particular output. When the output is turned back on, the over current tests will be initiated.

When an output switch is in an over current situation, a fault is logged to the USM and data logger. The system fault light will be activated while any over current situation exists.

*Circuit Activation Detection/Diagnostics.* When an output driver is intended to be ON, and a load is not detected at the output, the system will generate a network tag to indicate open circuit ("no-load") for the specific output. The tag can be used by the ES-Key™ network for diagnostics or indication. The minimum load current to activate this tag is 4 amps nominal. During an over current shutdown condition, this tag will be active for the particular output.



Likewise, a separate tag is generated to indicate that a load is operating within the proper limits (see section 3.4).

#### 3.2.1. Flash outputs

The PDM outputs have the capability to flash at two flash periods: 150 Hz and 75 Hz. Output memory spaces 12 - 19 control the output flash feature and output memory space 20 controls the flash period (see section 3.4). Activate an outputs flash output (output memory space 12-19) to begin flashing the output. The physical output (output memory space 0-7) should be OFF.

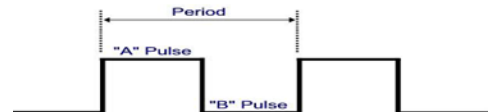
Outputs 0 - 3 flash on the "A" pulse, and outputs 4 - 7 flash on the "B" pulse. The period length is determined by the flash rate. This logic makes implementing alternating flashers quite simple.



  607 NW 27th Ave Ocala, FL 34475 Phone : (352) 629-5020 Fax : (352)-629-2902	<b>FOR EXTERNAL DISTRIBUTION</b>			<b>PAGE</b>	6 of 18	
	<b>OPERATION MANUAL</b>			<b>DATE</b>	1/22/2015	
	<b>PRODUCT GROUP</b>	ES-Key	<b>P/N</b>	FSG-MNL-00110	<b>REV</b>	1.00
	<b>PRODUCT</b>	8 PDM module with Inputs			<b>BY</b>	GMC

When the physical output is ON and its flash output is ON the flash occurs on the opposite pulse. For example, output 1 normally flashes on the "A" pulse, but when its flash output (output memory space 13) and its physical output (output memory space 1) are activated together the output flashes on the "B" pulse.

Output memory space 0	Output memory space 12	Result
OFF	OFF	Physical output 0 (pin 1) is OFF
ON	OFF	Physical output 0 (pin 1) is ON
OFF	ON	Physical output 0 (pin 1) is flashing on the "A" pulse
ON	ON	Physical output 0 (pin 1) is flashing on the "B" pulse

Output memory space 4	Output memory space 16	Result
OFF	OFF	Physical output 4 (pin 5) is OFF
ON	OFF	Physical output 4 (pin 5) is ON
OFF	ON	Physical output 4 (pin 5) is flashing on the "B" pulse
ON	ON	Physical output 4 (pin 5) is flashing on the "A" pulse

### 3.2.2. Pulse Width Modulate (PWM) outputs

Any output can be controlled ON at reduced power by activating its PWM output (see section 3.4).

Output memory space 0	Output memory space 24	Result
OFF	OFF	Physical output 0 (pin 1) is OFF
ON	OFF	Physical output 0 (pin 1) is ON
OFF	ON	Physical output 0 (pin 1) is ON at 60% PWM
ON	ON	Physical output 0 (pin 1) is ON (no PWM)

For example, as shown in the table above, if the output and PWM are activated the load for a physical output will be ON. To set the physical output to PWM (reduced power) mode it is necessary only to shed the primary output address for the desired output.

 607 NW 27th Ave Ocala, FL 34475 Phone : (352) 629-5020 Fax : (352)-629-2902	FOR EXTERNAL DISTRIBUTION <b>OPERATION MANUAL</b>			PAGE	7 of 18
	PRODUCT GROUP	ES-Key	P/N	FSG-MNL-00110	DATE
PRODUCT	8 PDM module with Inputs			REV	1.00
				BY	GMC

**3.2.3. Output polarity selection**

Output 0-3 are always positive the polarity of output 4-7 is selected by setting the output polarity shunts and the input/output dip switches (located inside of the case) to the desired positions. Table 4 and 5 shows the settings to select the output configurations of outputs 4 - 7.

OUTPUT	DIP SWITCH	
4	IN3/OUT4	UP
5	IN2/OUT5	UP
6	IN1/OUT6	UP
7	IN0/OUT7	UP

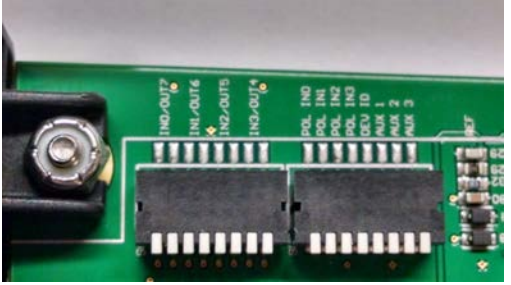

Figure 6 Dip Switch selection switches.

Table 5. Default Dip Switch Settings.

Output 4		Output 5		Output 6		Output 7	
Shunt H2-H3		Shunt H4-H5		Shunt H6-H7		Shunt H8-H9	
POSITIVE	POS 1	POSITIVE	POS 1	POSITIVE	POS 1	POSITIVE	POS 1
NEGATIVE	POS 2	NEGATIVE	POS 2	NEGATIVE	POS 2	NEGATIVE	POS 2

Table 6. Default Dip Switch Settings.

(Note: Selection switches are only read at power up).

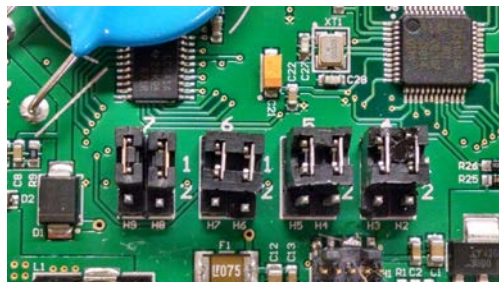



Figure 7. Output polarity selection Shunts.



  607 NW 27th Ave Ocala, FL 34475 Phone : (352) 629-5020 Fax : (352)-629-2902	FOR EXTERNAL DISTRIBUTION			PAGE	8 of 18
	<b>OPERATION MANUAL</b>			DATE	1/22/2015
PRODUCT GROUP	ES-Key	P/N	FSG-MNL-00110	REV	1.00
PRODUCT	<b>8 PDM module with Inputs</b>			BY	GMC

### 3.3. Module type and address

The PDM is recognized by the ES-Key Professional software as a PDM module (device type 1), or as a *switch input/output* module (device type 4) depending on the position of the selector switch used for device type identification (see section 3.3.1).

#### 3.3.1. Device type selection

The device type is selected by setting the selection switch (located inside of the case) to the desired position. The switch is labeled DEV ID and is directly related to the device type. When the switch is down it is a device type 1. When the switch is up it is a device type 4.

The address for both versions is selected by rotating the address switch to the desired value (0-15). Use an address selection tool (or a #1 Philips screwdriver) to set the position of the switch to the desired address.

(Note: Selection switches are only read at power up).

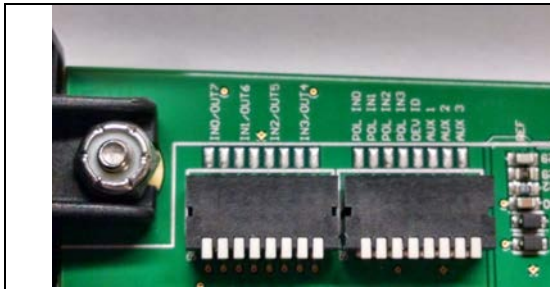

Figure 8. Selection switches.

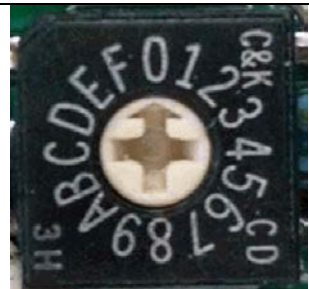



Figure 9. Address switch



Figure 10 Address selection tool.



  607 NW 27th Ave Ocala, FL 34475 Phone : (352) 629-5020 Fax : (352)-629-2902	<b>FOR EXTERNAL DISTRIBUTION</b>			<b>PAGE</b>	9 of 18	
	<b>OPERATION MANUAL</b>			<b>DATE</b>	1/22/2015	
	<b>PRODUCT GROUP</b>	ES-Key	<b>P/N</b>	FSG-MNL-00110	<b>REV</b>	1.00
	<b>PRODUCT</b>	<b>8 PDM module with Inputs</b>			<b>BY</b>	<b>GMC</b>

### 3.4. Input/output memory space

The PDM uses standard ES-Key defined input and output memory space. The polarity selectable inputs are mapped into the input space, and the outputs are mapped into the output space.

INPUT MEMORY SPACE	
INPUT	DESCRIPTION
0	Physical input 0
1	Physical input 1
2	Physical input 2
3	Physical input 3
4	<i>reserved</i>
5	<i>reserved</i>
6	<i>reserved</i>
7	<i>reserved</i>
8	Output 0 active tag
9	Output 1 active tag
10	Output 2 active tag
11	Output 3 active tag
12	Output 4 active tag
13	Output 5 active tag
14	Output 6 active tag
15	Output 7 active tag
16	<i>reserved</i>
17	<i>reserved</i>
18	<i>reserved</i>
19	<i>reserved</i>
20	Output 0 circuit open tag
21	Output 1 circuit open tag
22	Output 2 circuit open tag
23	Output 3 circuit open tag
24	Output 4 circuit open tag
25	Output 5 circuit open tag
26	Output 6 circuit open tag
27	Output 7 circuit open tag
28	<i>reserved</i>
29	<i>reserved</i>
30	<i>reserved</i>
31	<i>reserved</i>

OUTPUT MEMORY SPACE	
OUTPUT	LOCATION
0	Physical output 0
1	Physical output 1
2	Physical output 2
3	Physical output 3
4	Physical output 4
5	Physical output 5
6	Physical output 6
7	Physical output 7
8	<i>reserved</i>
9	<i>reserved</i>
10	<i>reserved</i>
11	<i>reserved</i>
12	Flash output 0
13	Flash output 1
14	Flash output 2
15	Flash output 3
16	Flash output 4
17	Flash output 5
18	Flash output 6
19	Flash output 7
20	Flash period (ON = 150Hz, OFF = 75Hz)
21	<i>reserved</i>
22	<i>reserved</i>
23	<i>reserved</i>
24	PWM output 0
25	PWM output 1
26	PWM output 2
27	PWM output 3
28	PWM output 4
29	PWM output 5
30	PWM output 6
31	PWM output 7

  607 NW 27th Ave Ocala, FL 34475 Phone : (352) 629-5020 Fax : (352)-629-2902	<b>FOR EXTERNAL DISTRIBUTION</b>			<b>PAGE</b>	10 of 18	
	<b>OPERATION MANUAL</b>			<b>DATE</b>	1/22/2015	
	<b>PRODUCT GROUP</b>	ES-Key	<b>P/N</b>	FSG-MNL-00110	<b>REV</b>	1.00
	<b>PRODUCT</b>	<b>8 PDM module with Inputs</b>			<b>BY</b>	<b>GMC</b>

## 4. Connector Description

The module has one connector and one power input stud. The following definitions apply:

### 4.1. Connector Pin Out

Mating connector: Deutsch DTM06-12SA (GRAY) Mating sockets: 0462-201-20141 Wedge lock: WM12S      Recommended wire gage: 18-24 AWG		
PIN	CIRCUIT	DESCRIPTION
1	Output 0	Digital output (positive polarity, 7.5A)
2	CAN High	ES-Key CAN, SAE J1939 Proprietary, 250 kbits/S
3	CAN Shield	ES-Key CAN, SAE J1939 Proprietary, 250 kbits/S
4	Output 2	Digital output (positive polarity, 7.5A)
5	Output 4 / Input 3	Digital output (positive polarity, 7.5A)
		Digital output (negative polarity, .25A)
		Digital Input (positive polarity)
		Digital Input (negative polarity)
6	Output 6 / Input 1	Digital output (positive polarity, 7.5A)
		Digital output (negative polarity, .25A)
		Digital Input (positive polarity)
		Digital Input (negative polarity)
7	Output 7 / Input 0	Digital output (positive polarity, 7.5A)
		Digital output (negative polarity, .25A)
		Digital Input (positive polarity)
		Digital Input (negative polarity)
8	Output 5 / Input 2	Digital output (positive polarity, 7.5A)
		Digital output (negative polarity, .25A)
		Digital Input (positive polarity)
		Digital Input (negative polarity)
9	Output 3	Digital output (positive polarity, 7.5A)
10	Output 1	Digital output (positive polarity, 7.5A)
11	CAN Low	ES-Key CAN, SAE J1939 Proprietary, 250 kbits/S
12	Supply -	Module supply (vehicle ground)

Mating terminal: #10 ring terminal Recommended wire gage: 8 AWG (for maximum load on the 8 outputs)		
PIN	CIRCUIT	DESCRIPTION
STUD	Supply +	Module supply (+9VDC...+32VDC)

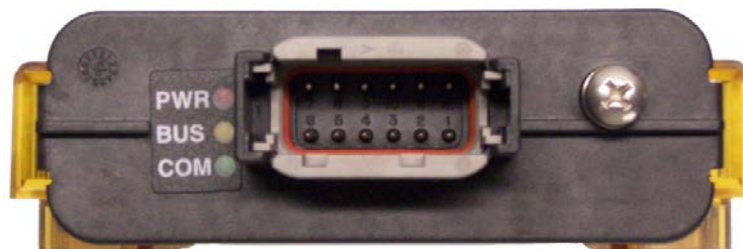



Figure 11. Connector identification.

  607 NW 27th Ave Ocala, FL 34475 Phone : (352) 629-5020 Fax : (352)-629-2902	FOR EXTERNAL DISTRIBUTION			PAGE	11 of 18
	<b>OPERATION MANUAL</b>			DATE	1/22/2015
PRODUCT GROUP	ES-Key	P/N	FSG-MNL-00110	REV	1.00
PRODUCT	8 PDM module with Inputs			BY	GMC

#### 4.1.1. Terminating resistor requirement (CAN communication)

Two terminating resistors (120 Ohm) are required on the CAN bus for proper operation (one at each end of the CAN bus). Only two terminating resistors are allowed on a CAN bus.

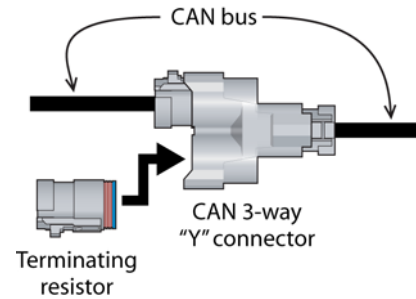

Terminating resistor            p/n DT06-3S-P006

CAN 3-way "Y" connector    p/n DT04-3P-P007



#### 4.2. System compatibility

The PDM Module is compatible with other Class 1 CAN devices.

  607 NW 27th Ave Ocala, FL 34475 Phone : (352) 629-5020 Fax : (352)-629-2902	FOR EXTERNAL DISTRIBUTION			PAGE	12 of 18	
	<b>OPERATION MANUAL</b>			DATE	1/22/2015	
	PRODUCT GROUP	ES-Key	P/N	FSG-MNL-00110	REV	1.00
	PRODUCT	8 PDM module with Inputs			BY	GMC

## 5. Legacy Part Number Compatibility Chart

### 5.1. Legacy Compatibility

The new 610-00034 replaces several existing part numbers. The following configurations will configure the new module to work as existing part numbers. (Note: The default configuration will be set to a 104434)

#### 5.1.1. 104434

The legacy 104434 PDM module had 8 positive 7.5 Amp outputs. Reference the table below to set the module to a 104434 configuration.

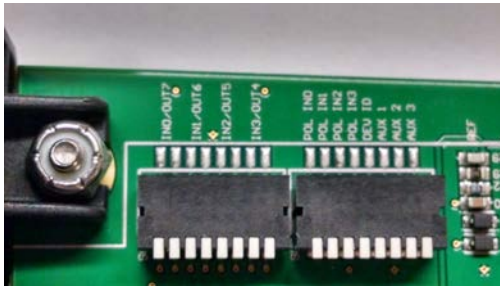

Figure 12 Dip Switch selection switches.

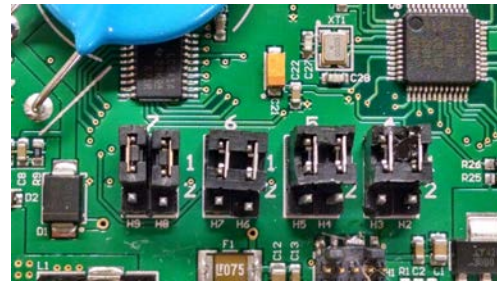



Figure 13 Output polarity selection Shunts.

## LEGACY 104434

Shunt H2 and H3	Position 1
Shunt H4 and H5	Position 1
Shunt H6 and H7	Position 1
Shunt H8 and H9	Position 1
Dip SW IN0 / OUT7	Position UP (Done in Pairs)
Dip SW IN1 / OUT6	Position UP (Done in Pairs)
Dip SW IN2 / OUT5	Position UP (Done in Pairs)
Dip SW IN3 / OUT4	Position UP (Done in Pairs)
Dip SW POL IN0	N/A
Dip SW POL IN1	N/A
Dip SW POL IN2	N/A
Dip SW POL IN3	N/A
Dip SW DEV ID	Position Down
DIP SW AUX 1	N/A
DIP SW AUX 2	N/A
DIP SW AUX 3	N/A

Table 7. Legacy 104434 configuration.

  607 NW 27th Ave Ocala, FL 34475 Phone : (352) 629-5020 Fax : (352)-629-2902	FOR EXTERNAL DISTRIBUTION			PAGE	13 of 18
	<b>OPERATION MANUAL</b>			DATE	1/22/2015
PRODUCT GROUP	ES-Key	P/N	FSG-MNL-00110	REV	1.00
PRODUCT	8 PDM module with Inputs			BY	GMC

### 5.1.2. 104528

The legacy 104528 PDM module had 6 positive 7.5 Amp outputs and 2 polarity selectable inputs. Reference the table below to set the module to a 104528 configuration.

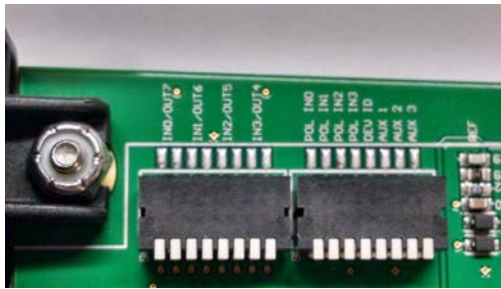

Figure 14 Dip Switch selection switches.

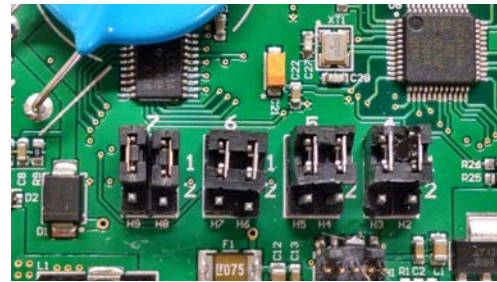



Figure 15 Output polarity selection Shunts.

## LEGACY 104528

Shunt H2 and H3	Position 1
Shunt H4 and H5	Position 1
Shunt H6 and H7	Position 1
Shunt H8 and H9	Position 1
Dip SW IN0 / OUT7	Position DOWN (Done in Pairs)
Dip SW IN1 / OUT6	Position DOWN (Done in Pairs)
Dip SW IN2 / OUT5	Position UP (Done in Pairs)
Dip SW IN3 / OUT4	Position UP (Done in Pairs)
Dip SW POL IN0	Reference section 3.1.1
Dip SW POL IN1	Reference section 3.1.1
Dip SW POL IN2	N/A
Dip SW POL IN3	N/A
Dip SW DEV ID	Position Down
DIP SW AUX 1	N/A
DIP SW AUX 2	N/A
DIP SW AUX 3	N/A

Table 8. Legacy 104528 configuration.

  607 NW 27th Ave Ocala, FL 34475 Phone : (352) 629-5020 Fax : (352)-629-2902	FOR EXTERNAL DISTRIBUTION			PAGE	14 of 18
	<b>OPERATION MANUAL</b>			DATE	1/22/2015
PRODUCT GROUP	ES-Key	P/N	FSG-MNL-00110	REV	1.00
PRODUCT	<b>8 PDM module with Inputs</b>			BY	GMC

### 5.1.3. 104529

The legacy 104529 PDM module had 4 positive 7.5 Amp outputs and 4 polarity selectable inputs. Reference the table below to set the module to a 104529 configuration.

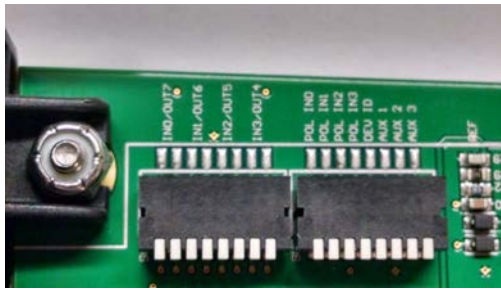

Figure 16 Dip Switch selection switches.

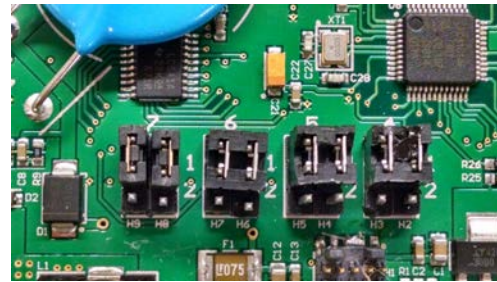



Figure 17 Output polarity selection Shunts.

## LEGACY 104529

Shunt H2 and H3	Position 1
Shunt H4 and H5	Position 1
Shunt H6 and H7	Position 1
Shunt H8 and H9	Position 1
Dip SW IN0 / OUT7	Position DOWN (Done in Pairs)
Dip SW IN1 / OUT6	Position DOWN (Done in Pairs)
Dip SW IN2 / OUT5	Position DOWN (Done in Pairs)
Dip SW IN3 / OUT4	Position DOWN (Done in Pairs)
Dip SW POL IN0	Reference section 3.1.1
Dip SW POL IN1	Reference section 3.1.1
Dip SW POL IN2	Reference section 3.1.1
Dip SW POL IN3	Reference section 3.1.1
Dip SW DEV ID	Position Down
DIP SW AUX 1	N/A
DIP SW AUX 2	N/A
DIP SW AUX 3	N/A

Table 9. Legacy 104529 configuration.

  607 NW 27th Ave Ocala, FL 34475 Phone : (352) 629-5020 Fax : (352)-629-2902	FOR EXTERNAL DISTRIBUTION			PAGE	15 of 18
	<b>OPERATION MANUAL</b>			DATE	1/22/2015
PRODUCT GROUP	ES-Key	P/N	FSG-MNL-00110	REV	1.00
PRODUCT	8 PDM module with Inputs			BY	GMC

#### 5.1.4. 105071

The legacy 105071 PDM module had 4 positive 7.5 Amp outputs and 4 negative .25 Amp outputs. Reference the table below to set the module to a 105071 configuration.

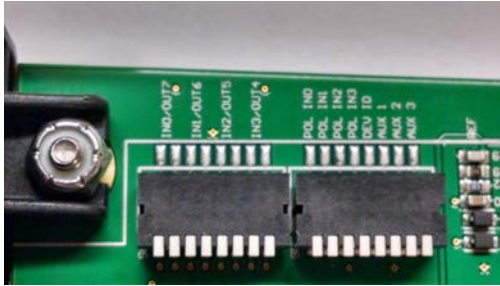

Figure 18 Dip Switch selection switches.

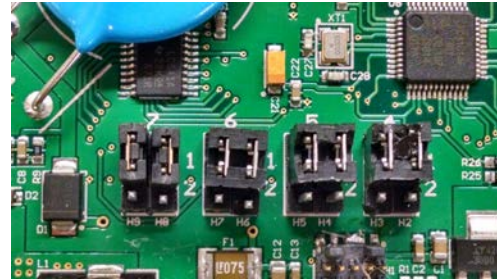



Figure 19 Output polarity selection Shunts.

## LEGACY 105071

Shunt H2 and H3	Position 2
Shunt H4 and H5	Position 2
Shunt H6 and H7	Position 2
Shunt H8 and H9	Position 2
Dip SW IN0 / OUT7	Position UP (Done in Pairs)
Dip SW IN1 / OUT6	Position UP (Done in Pairs)
Dip SW IN2 / OUT5	Position UP (Done in Pairs)
Dip SW IN3 / OUT4	Position UP (Done in Pairs)
Dip SW POL IN0	N/A
Dip SW POL IN1	N/A
Dip SW POL IN2	N/A
Dip SW POL IN3	N/A
Dip SW DEV ID	Position Down
DIP SW AUX 1	N/A
DIP SW AUX 2	N/A
DIP SW AUX 3	N/A

Table 10. Legacy 105071 configuration.



 607 NW 27th Ave Ocala, FL 34475 Phone : (352) 629-5020 Fax : (352)-629-2902	FOR EXTERNAL DISTRIBUTION <b>OPERATION MANUAL</b>			PAGE 16 of 18
	PRODUCT GROUP ES-Key	P/N FSG-MNL-00110	DATE 1/22/2015	REV 1.00
PRODUCT 8 PDM module with Inputs			BY GMC	

## 6. Mounting

### 6.1. Mounting dimensions

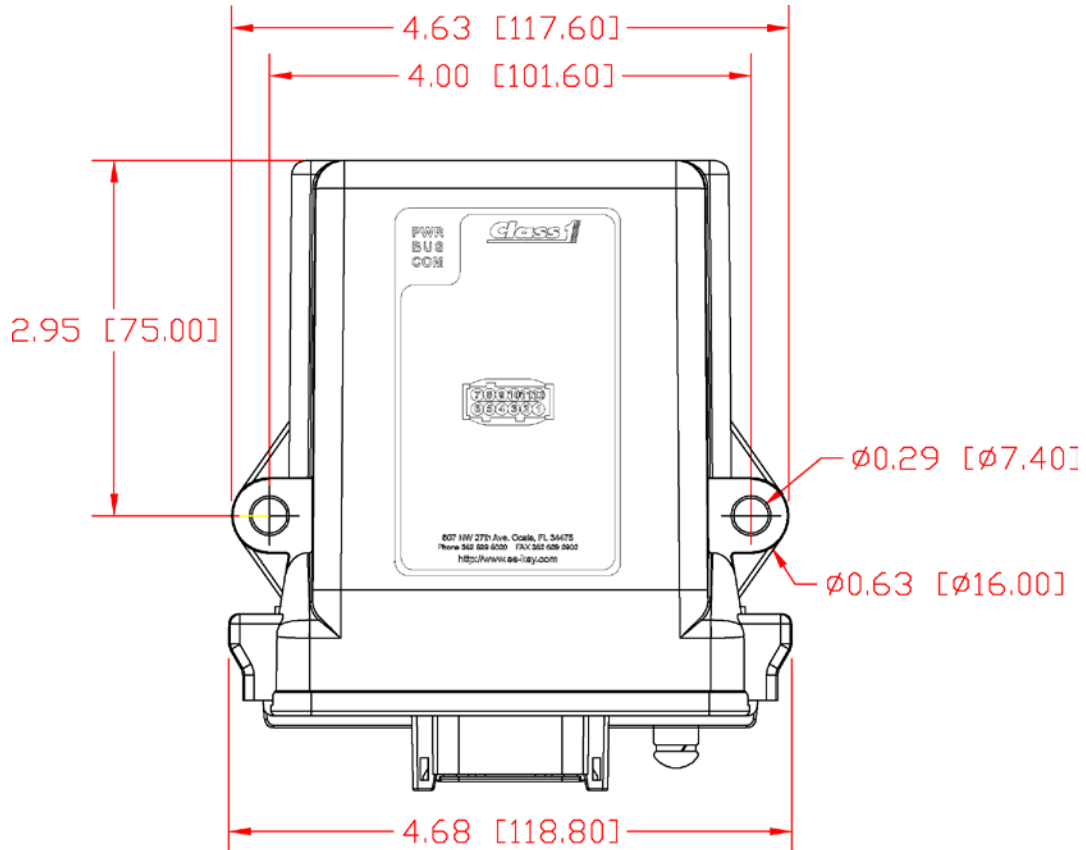

Figure 20. Mounting dimensions – inches [millimeters].

### 6.2. Mounting notes

When mounting the module vertically, make certain the connector is pointed down so as to eliminate the possibility of standing water in the connector.

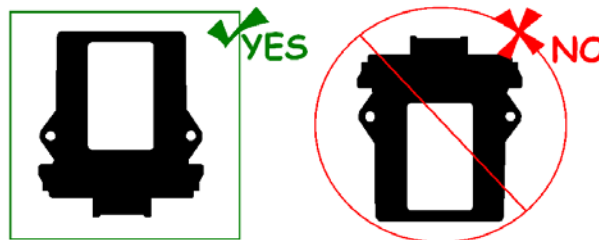



Figure 21. Vertical mounting requirement.

  607 NW 27th Ave Ocala, FL 34475 Phone : (352) 629-5020 Fax : (352)-629-2902	FOR EXTERNAL DISTRIBUTION <b>OPERATION MANUAL</b>			PAGE	17 of 18
	PRODUCT GROUP	ES-Key	P/N	FSG-MNL-00110	DATE
PRODUCT	8 PDM module with Inputs			REV	1.00
				BY	GMC

## 7. Diagnostics

The Power Distribution module has 3 diagnostic LEDs which are viewable through the top of its amber enclosure.

**PWR** - +5VDC logic power  
**BUS** - +9...+32VDC Module power  
**COM** - Module status indicator

The COM LED indicates the module's CAN communication status.

**On Solid**  
 Module on-line



**Flashing slow (2Hz)**  
 CAN bus okay, but the module is not receiving messages from the Universal System Manager (USM).

**Flashing fast (8Hz)**  
 CAN bus error, no communications or not connected.

**Flashing fast (20Hz)**  
 Output Over Current Indication

**Double flash**  
 CAN bus has an *ACTIVE* error, no communications.



  607 NW 27th Ave Ocala, FL 34475 Phone : (352) 629-5020 Fax : (352)-629-2902	FOR EXTERNAL DISTRIBUTION			PAGE	18 of 18	
	<b>OPERATION MANUAL</b>				DATE	1/22/2015
	PRODUCT GROUP	ES-Key	P/N	FSG-MNL-00110	REV	1.00
	PRODUCT	8 PDM module with Inputs			BY	GMC

## 8. Glossary

<b>PDM</b>	<u>P</u> ower <u>D</u> istribution <u>M</u> odule
<b>LED</b>	<u>L</u> ight <u>E</u> mitting <u>D</u> iode. The lights on the display used to show tank level and information.
<b>CAN</b>	<u>C</u> ontroller <u>A</u> rea <u>N</u> etwork. SAE J1939 communication method.
<b>EEPROM</b>	<u>E</u> lectrically <u>E</u> rasable <u>P</u> rogrammable <u>R</u> ead- <u>O</u> nly <u>M</u> emory. The memory of the tank level display, used to store the display information (tank level points, display type, dim value, etc).
<b>OEM</b>	<u>O</u> riginal <u>E</u> quipment <u>M</u> anufacturer.
<b>SAE</b>	<u>S</u> ociety of <u>A</u> utomotive <u>E</u> ngineers.
<b>ESD</b>	<u>E</u> lectro <u>S</u> tatic <u>D</u> ischarge.
<b>IP</b>	<u>I</u> ngress <u>P</u> rotection (IP 67, etc).
<b>p/n</b>	part <u>n</u> umber

## 9. Technical details

Product category	ES-KEY
Voltage range	+9VDC...+32VDC
Power consumption	Supply+ input (stud)
@13.8VDC	65mA <sup>(1)</sup>
@27.6VDC	85mA <sup>(1)</sup>
Output current capability	7.5A per output positive .25A per output negative
Input current draw	2mA per input (positive or ground polarity)
Operational temperature range	-40°C...+85°C
Environmental range	IP 67
CAN specification	SAE J1939 proprietary, 250 Kbits/second
Protection	Reverse voltage protection (stud and pin 12)
	CAN buses protected to 24V
	ESD voltage protected to SAE J1113 specification for heavy duty trucks (24V)
	Transient voltage protected to SAE J1113 specification for heavy duty trucks (24V)
	Load dump voltage protected to SAE J1113 specification for heavy duty trucks (24V)
Dimensions (W x L x H) in inches [mm]	4.680 [118.80] x 5.240 [133.10] x 1.420 [36.07]

<sup>(1)</sup> Does not include current draw due to outputs connected to external loads.

### 9.1. WEEE (Waste of Electrical and Electronic Equipment) directive



This symbol [crossed-out wheeled bin WEEE Annex IV] indicates separate collection of waste electrical and electronic equipment in the European Union countries.

Please do not throw the equipment into the domestic refuse.

Each individual European Union member state has implemented the WEEE regulations into national law in slightly different ways. Please follow your national law when you want to dispose of any electrical or electronic products.

**More details can be obtained from your national WEEE recycling agency.**