

CUSTOMER ORDER SPECIFICATION FOR HALE RSDM FIRE PUMP END

Customer Name: _____ Customer P.O. NO.: _____
 Order Prepared By: _____ Hale Customer NO.: _____ Date: _____
 Fire Dept. Name: _____ City: _____ State: _____
 Requested Delivery Date: _____ Max. Elevation for Pump Test: _____ FT
 Reference Specifications: _____

Engine: Mfr: _____ Model: _____ Horsepower: _____ @ _____ RPM
 Full Load Governed RPM: _____ Peak Torque: _____ LB/FT @ _____ RPM
 Application confirmed with: (for applications not on list) _____

1. Pump Model (Circle price of Model Desired): * Select Ratio in Step 4 below

FLOW GPM (LPM)	1000 (4000)	1250 (5000)	1500 (N/A)	Material
RSDM	\$9,672	\$9,672	\$9,672	Cast Iron
RSDM	CONSULT FACTORY			Bronze

2. NFPA Rating: Options Available

- None N/C
- Provided \$575
- Dual Rating (US GPM/LPM) \$775

3. Pump Ratio (Circle Ratio Desired):

RATIO	DESIGNATION
1.29	-12
1.40	-14
1.59	-15
1.80	-18
1.97	-20
2.16	-21
2.37	-23

4. Gearbox Position (Check one Box):

- Vertical N/C
- Horizontal LH \$175
- Horizontal RH \$175

GEARBOX POSITION

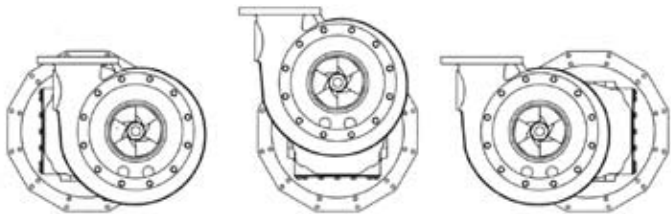

Horizontal Left Hand Vertical Horizontal Right Hand

GEARBOX POSITION

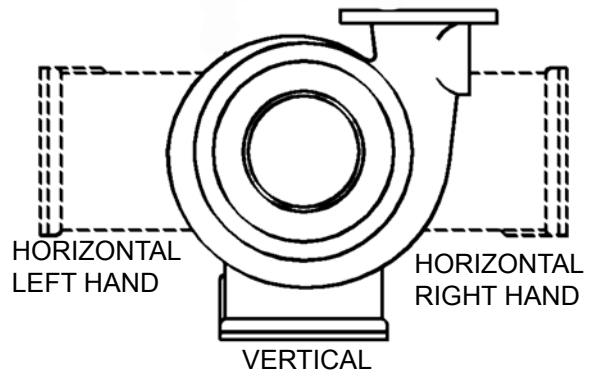

5. Discharge Position: (Check One Box)

- UP (Shown Above) STD
- LEFT \$ 250
- RIGHT \$ 250
- DOWN (Inverted) \$ 250

6. Discharge Options (Check One Box):

- Open N/C
- Cast iron manifold (with blanks) \$1155

7. Bellhousing and Coupler: (Check Two Boxes)

- SAE 3 x SAE 2 BELL HOUSING ADAPTER \$3518
- DIRECT MOUNT SAE #3 or #4 FLYWHEEL HOUSING N/C
- SAE#10 Elastomeric \$1711
- SAE #11-1/2 Elastomeric \$1711

NOTE: Hale reserves the right to make improvements in design and materials and changes in price without notice
 ALL PRICES ARE U.S. DOLLARS F.O.B. CONSHOHOCKEN, PA 19428 USA

8. Suction Ends (Check One Box):

- 6" VICTAULIC **STD**
- Hale metric bolt Flange \$ 495
- 5" NST Short \$ 962
- 5" NST Long \$ 962
- 6" NST Short \$ 962
- 6" NST Long \$ 962
- 6" NST w/115 Flange \$ 918
- 6" NST Suction Manifold w/MIV-E Consult Factory

9. Connection K: (Check One Box)

CONNECTION K	Cast Iron
Blank/Open	12
2-1/2 NPT	60
3" NPT	94
TRV w/115	416
TRV wo/115	678
Zinc Anode w/flange	170
Magnesium Anode w/flange	112

SAE FLYWHEEL DIMENSIONS			
		11-½ CLUTCH	10 CLUTCH
A	NO.	8 EQUAL SPACE	8 EQUAL SPACE
	SIZE	3/8 - 16	3/8 - 16
B		13.125	11.625
C		13.875	12.375
D		1.56	2.12

SAE FLYWHEEL HOUSING DIMENSIONS				
		NO. 2	NO. 3	NO.4
E	NO.	12	12	12
	SIZE	3/8 - 16	3/8 - 16	3/8 - 16
F		17.625	16.125	14.250
G		18.375	16.875	15.000

NOTE: Engine Application data and compatibility is the responsibility of the purchaser.

FOR ADDITIONAL OR LOOSE ACCESSORIES, VALVES, FLANGES, SEE SEPARATE ACCESSORY PAGE PRICE LIST AND ATTACH TO PUMP ORDER



Hale Products, Inc. A Unit of IDEX Corp. 700 Spring Mill Avenue Conshohocken, PA 19428 USA
 TEL: 610/825-6300 1-800/220-HALE FAX: 610/825-9615 www.haleproducts.com

Class 1 A Unit of IDEX Corp. 607 NW 27th Avenue Ocala FL 34475 USA
 Tel: 352-629-5020 800-533-3569 Fax: 352-629-2902 www.class1.com