

**CUSTOMER ORDER SPECIFICATION FOR HALE RMC PEDESTAL FIRE PUMP**

Customer Name: \_\_\_\_\_ Customer P.O. NO.: \_\_\_\_\_  
 Order Prepared By: \_\_\_\_\_ Hale Customer NO.: \_\_\_\_\_ Date: \_\_\_\_\_  
 Fire Dept. Name: \_\_\_\_\_ City: \_\_\_\_\_ State: \_\_\_\_\_  
 Requested Delivery Date: \_\_\_\_\_  
 Max. Elevation for Pump Test: \_\_\_\_\_ FT Panel Width: \_\_\_\_\_ IN.  
 Reference Specifications: \_\_\_\_\_

Engine: Mfr: \_\_\_\_\_ Model: \_\_\_\_\_ Horsepower: \_\_\_\_\_ @ \_\_\_\_\_ RPM  
 Full Load Governed RPM: \_\_\_\_\_ Peak Torque: \_\_\_\_\_ LB/FT @ \_\_\_\_\_ RPM  
 Application confirmed with : \_\_\_\_\_

**Additional Information Required for PTO Drive:**

Truck Transmission: \_\_\_\_\_ Manufacturer: \_\_\_\_\_ Model: \_\_\_\_\_  
 PTO: Model \_\_\_\_\_, % \_\_\_\_\_, Torque Rating \_\_\_\_\_, Rotation \_\_\_\_\_

**1. Pump Model (Circle price of Model Desired):**

\* See Rating Charts for Impeller Size & Speed

Flow GPM (LPM)	1000 (4000)	1250 (5000)	1500 (N/A)	Material
Pump Model (Metric)	100 (400M)	125 (500M)	150 (N/A)	
RMC-0*	\$7,374	\$7,374	\$7,374	Cast Iron
RMC-1*	\$6,974	\$6,974	\$6,974	Cast Iron
RMC-0*	CONSULT FACTORY			Bronze
RMC-1*	CONSULT FACTORY			Bronze

**1A. Pump Light Kit Option (Check Applicable Box(es)):**

- NFPA Midship Light Kit \$156
- No Light Kit N/C

**1B. Pump Manual Option (Check Applicable Box(es)):**

- Paper Manual version \$36
- CD Version (2) N/C

**1C. Panel Placard Option (Check Applicable Box(es)):**

- Stamped S/N Placard \$29
- No Panel Placard N/C

**2. NFPA Rating: Options Available**

- None N/C
- Provided \$200
- Dual Rating (GPM/LPM) \$290

**3. Pump Mounting**

- Top Mounting Small Profile Pedestal N/C
- Bottom Mounting Small Profile Pedestal N/C
- Bottom Mount Pedestal \$320

**4. Suction End: (Check One Box)**

- NONE (6 x 11 ASA FLANGE CONNECTION) N/C
- 6 INCH NPTF FLANGE (Cast Iron) \$270
- 6 INCH NPTF FLANGE (Stainless) \$820

**5. Discharge Manifold (Check One Box):**

- NONE (4 x 9 ASA FLANGE CONNECTION) N/C
- 4 INCH NPTF FLANGE (Cast Iron) \$250
- 4 INCH NPTF FLANGE (Stainless) \$320

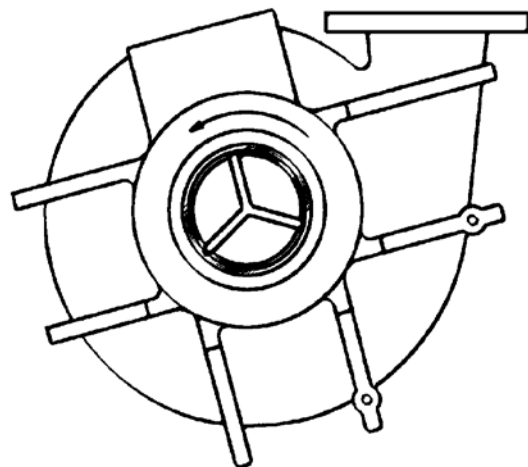

RMC Pump

NOTE: Hale reserves the right to make improvements in design and materials and changes in price without notice  
 ALL PRICES ARE U.S. DOLLARS F.O.B. CONSHOHOCKEN, PA 19428

6. Volute Position: (Position 1 is Standard/Normal position) (Circle Position Desired)

- Vertical Position N/C
- Other Position \$250

# RMC SERIES REAR MOUNT PUMP

PUMP MAY BE ROTATED IN 30 DEG INCREMENTS

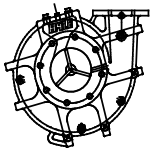

POSITION-1  
0 DEG.  
(STANDARD)

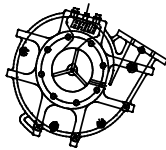

POSITION-2  
30 DEG.

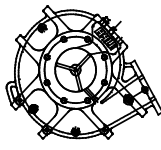

POSITION-3  
60 DEG.

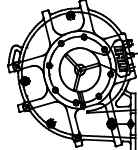

POSITION-4  
90 DEG.

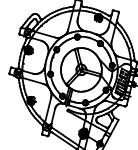

POSITION-5  
120 DEG.

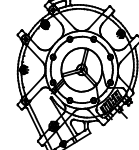

POSITION-6  
150 DEG.

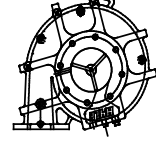

POSITION-7  
180 DEG.

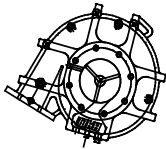

POSITION-8  
210 DEG.

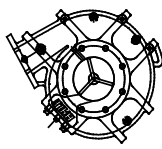

POSITION-9  
240 DEG.

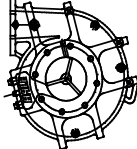

POSITION-10  
270 DEG.

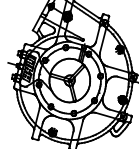

POSITION-11  
300 DEG.

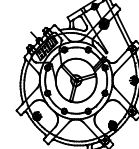

POSITION-12  
330 DEG.

7. Pro Tech Warranty (FIRE SERVICE APPLICATIONS ONLY) (NET PRICE, NO DISCOUNTS)

- Standard 5 Year Warranty (Parts and Labor for the first two years, parts only years 3-5) N/C
- Pro Tech Gold Warranty - 1 Additional Year of Labor \$250
- Pro Tech Gold Warranty - 2 Additional Years of Labor \$750
- Pro Tech Gold Warranty - 3 Additional Years of Labor \$1500

FOR ADDITIONAL OR LOOSE ACCESSORIES, VALVES, FLANGES, SEE SEPARATE ACCESSORY PAGE PRICE LIST AND ATTACH TO PUMP ORDER



Hale Products, Inc. A Unit of IDEX Corp. 700 Spring Mill Avenue Conshohocken, PA 19428 USA  
 TEL: 610/825-6300 1-800/220-HALE FAX: 610/825-9615 www.haleproducts.com

Class 1 A Unit of IDEX Corp. 607 NW 27th Avenue Ocala FL 34475 USA  
 Tel: 352-629-5020 800-533-3569 Fax: 352-629-2902 www.class1.com