

**CUSTOMER ORDER SPECIFICATION FOR HALE HP100-U FIRE PUMP**

Customer Name: \_\_\_\_\_ Customer P.O. NO.: \_\_\_\_\_  
 Order Prepared By: \_\_\_\_\_ Hale Customer NO.: \_\_\_\_\_ Date: \_\_\_\_\_  
 Fire Dept. Name: \_\_\_\_\_ City: \_\_\_\_\_ State: \_\_\_\_\_  
 Requested Delivery Date: \_\_\_\_\_ Max. Elevation for Pump Test: \_\_\_\_\_ FT  
 Reference Specifications: \_\_\_\_\_

Engine: Mfr: \_\_\_\_\_ Model: \_\_\_\_\_ Horsepower: \_\_\_\_\_ @ \_\_\_\_\_ RPM  
 Full Load Governed RPM: \_\_\_\_\_ Peak Torque: \_\_\_\_\_ LB/FT @ \_\_\_\_\_ RPM  
 Application confirmed with: (for applications not on list) \_\_\_\_\_  
 Truck Transmission: Manufacturer: \_\_\_\_\_ Model: \_\_\_\_\_  
 PTO: Model \_\_\_\_\_, % \_\_\_\_\_ Torque Rating \_\_\_\_\_, Rotation \_\_\_\_\_

**1. Pump Model (501-3230-01-0)**  
 HP100-U \$3,212

**FOR ADDITIONAL OR LOOSE ACCESSORIES,  
 VALVES, FLANGES, SEE SEPARATE  
 ACCESSORY PAGE PRICE LIST AND ATTACH  
 TO PUMP ORDER**

**2. Pump Rotation**  
 ENGINE ROTATION N/C

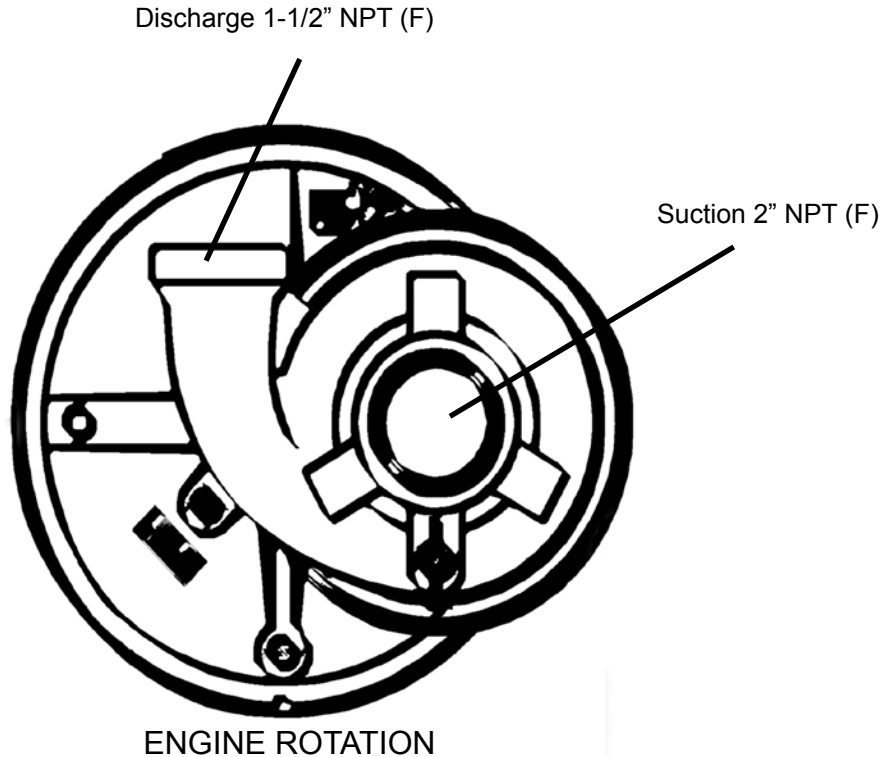

Hale Products, Inc. A Unit of IDEX Corp. 700 Spring Mill Avenue Conshohocken, PA 19428 USA  
 TEL: 610/825-6300 1-800/220-HALE FAX: 610/825-9615 www.haleproducts.com

Class 1 A Unit of IDEX Corp. 607 NW 27th Avenue Ocala FL 34475 USA  
 Tel: 352-629-5020 800-533-3569 Fax: 352-629-2902 www.class1.com

NOTE: Hale reserves the right to make improvements in design and materials and changes in price without notice  
 ALL PRICES ARE U.S. DOLLARS F.O.B. OCALA, FLORIDA 34475 USA