

CUSTOMER ORDER SPECIFICATION FOR HALE DE-ICING PUMPS

Customer Name: _____ Customer P.O. NO.: _____
 Order Prepared By: _____ Hale Customer NO.: _____ Date: _____
 Dept. Name: _____ City: _____ State: _____
 Requested Delivery Date: _____ Max. Elevation for Pump Test: _____ FT

DE-ICING PUMPS

MODEL	PART NUMBER	SUCTION & DISCHARGE	SHAFT SIZE 9(e)	KEY WIDTH	GEARBOX RATIO	VOLUTE POSITION	PUMP ROT.	LIST PRICE
2CBP3TTT	501-0480-02-0	2" NPT (F) x 1-1/2" NPT (F)	1-3/8"	3/8"	2.83	6	Engine	\$7287
2CBP3TTT	501-0480-12-0	2" NPT (F) x 1-1/2" NPT (F)	1-3/8"	3/8"	2.83	6	Opposite Engine	\$7287
2CBP3TTT	501-0480-14-0	2" NPT (F) x 1-1/2" NPT (F)	1-3/8"	3/8"	2.83	6	Opposite Engine	\$7287

METALLURGY

PUMP CONSTRUCTION	VOLUTE AND HEAD	IMPELLER & CLEARANCE RINGS	PUMP SHAFT & IMPELLER KEY
Bronze Fitted Pumps	Cast Iron	Bronze	Stainless Steel

STANDARD EQUIPMENT PACKAGE INCLUDED WITH DE-ICING MOUNTED PUMPS:

- Cast iron, bronze fitted, two stage centrifugal pump
- Self adjusting mechanical seal
- Heat treated steel alloy spur gears
- Stainless steel drive shaft with key
- Hydrostatic testing at 1000 PSI
- Weight: 120 lbs (54kg)
- (2) Operation and Maintenance Manuals

NOTE: The Hale 2CBP3TTT De-icing Pumps are compatible with Type I and IV de-icing fluid only

PUMP POSITION

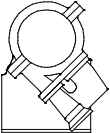
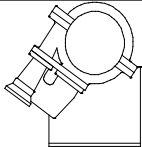
VOLUTE POSITION	ROTATION & POSITION NO.
	Engine Rotation Position 6
	Opp. Engine Rotation Position 12
	Opp. Engine Rotation Position 14

Other positions available - Contact Factory

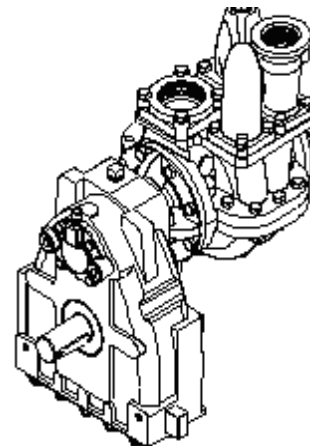

PART NUMBER	PART DESCRIPTION	KIT CONTENTS	WEIGHT LBS (KG)	LIST PRICE
545-1540-11-0	Level 1 Repair Kit for 2CBP3TTT	Includes gaskets, seals, oil seals, bearings, retaining rings & pump mechanical seal	5 (2)	\$708.42
546-1540-12-0	Pump Overhaul Kit for 2CBP3TTT	Includes Level 1 Repair Kit, impellers, pump-shaft, input shaft & gear	30 (14)	\$3663.53

FOR ADDITIONAL OPTIONAL EQUIPMENT, SEE HALE VALVES AND ACCESSORIES, PAGES A THROUGH F



Hale Products, Inc. A Unit of IDEX Corp. 700 Spring Mill Avenue Conshohocken, PA 19428 USA

TEL: 610/825-6300 1-800/220-HALE FAX: 610/825-9615 www.haleproducts.com

NOTE: Hale reserves the right to make improvements in design and materials and changes in price without notice

ALL PRICES ARE U.S. DOLLARS F.O.B. CONSHOHOCKEN, PA 19428

© 2009 Hale Products Inc, Printed in USA