

CUSTOMER ORDER SPECIFICATION FOR HALE DSD FIRE PUMP

Customer Name: _____ Customer P.O. NO.: _____
 Order Prepared By: _____ Hale Customer NO.: _____ Date: _____
 Fire Dept. Name: _____ City: _____ State: _____
 Requested Delivery Date: _____ Max. Elevation for Pump Test: _____ FT
 Reference Specifications: _____

Engine: Mfr: _____ Model: _____ Horsepower: _____ @ _____ RPM
 Full Load Governed RPM: _____ Peak Torque: _____ LB/FT @ _____ RPM
 Is Engine Listed in Hale Recommended Pump/Engine Combination List? YES No
 Application confirmed with:(for applications not on list) _____

1. Pump Model (Circle Price of Model Desired):

FLOW GPM (LPM)	750 (3000)	1000 (4000)	1250 (5000)	1500 (N/A)	Material
Pump Model (METRIC)	75 (300M)	100 (400M)	125 (500M)	150* (N/A)	
DRIVE UNIT REAR	\$11,105	\$11,105	\$11,105	\$11,659	Cast Iron
DRIVE UNIT FRONT	\$12,243	\$12,243	\$12,243	N/A	Cast Iron
DRIVE UNIT REAR	CONTACT FACTORY				Bronze
DRIVE UNIT FRONT	CONTACT FACTORY				Bronze

* Requires (2) 6 Inch Suction Inlets or Hale's optional weld and rams horn

NFPA Rating Certification Standard

1A. Pump Light Kit Option (Check Applicable Box(es)):

- NFPA Midship Light Kit \$156
- No Light Kit N/C

1B. Pump Manual Option (Check Applicable Box(es)):

- Paper Manual version \$36
- CD Version (2) N/C

1C. Panel Placard Option (Check Applicable Box(es)):

- Stamped S/N Placard \$29
- No Panel Placard N/C

2. NFPA Rating (Check Applicable Box(es)):

- Provided N/C
- Dual Rating (GPM/LPM) \$175

3. Drive Unit and Pump Ratio (Check One Box): N/C

MODEL	G SERIES			EXTRA LONG	
	RATIO	L	R	RATIO	XG
-15	1.58	STD	N/C	N/A	N/A
-17	1.71	STD	N/C	N/A	N/A
-19	1.86	STD	N/C	1.96	253
-21	2.05	STD	N/C	2.13	253
-23	2.28	STD	N/C	2.32	253
-25	N/A	N/A	N/A	2.55	253
-28	N/A	N/A	N/A	2.83	253

4. Volute Side Discharge (Check One Box):

CONNECTION K	Cast Iron
BLANK/OPEN	12
2-1/2 INCH NPT	60
3 INCH NPT	94
TRV w/115 Flange	416
TRV-L w/115 Flange	678
Magnesium Anode w/115 Flange	170
Zinc Anode w/115 Flange	112

5. Drive Unit Shift and Tach Cable (Check Boxes):

A. SHIFT OPTION (airshift included as standard):

- Customer Supplied Shift Control N/C
- VPS shift Control \$ 86

B. AUXILIARY OVERRIDE OPTION*

- Manual Shift Override, 72" cable \$1300
- Manual Shift Override, 55" cable \$1300
- Manual Shift Override, Turn Rod \$1300

C. TACHOMETER* (G series Only)

- No Cable or Panel Adapter N/C
- Panel Adapter Only \$ 123
- Cable and Panel Adapter \$ 230

NOTE: Hale reserves the right to make improvements in design and materials and changes in price without notice
 ALL PRICES ARE U.S. DOLLARS F.O.B. CONSHOHOCKEN, PA 19428 USA

6 Suction End (Check Box):

- 6" Victaulic N/C
- Rams Horn Weld Suction Tee \$ 900

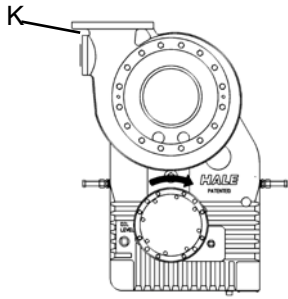

DRIVE UNIT REAR
("L" GEARBOX)
(FACING INPUT SHAFT)

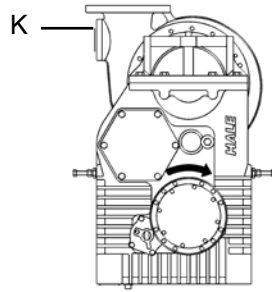

DRIVE UNIT FRONT
("R" GEARBOX)
(FACING INPUT SHAFT)

7. Volute Position (Circle Position Desired): (Position 21 is Standard)

- Vertical Position (21) N/C
- Other Positions \$100

POSSIBLE VOLUTE POSITIONS (22-1/2° INCREMENTS)

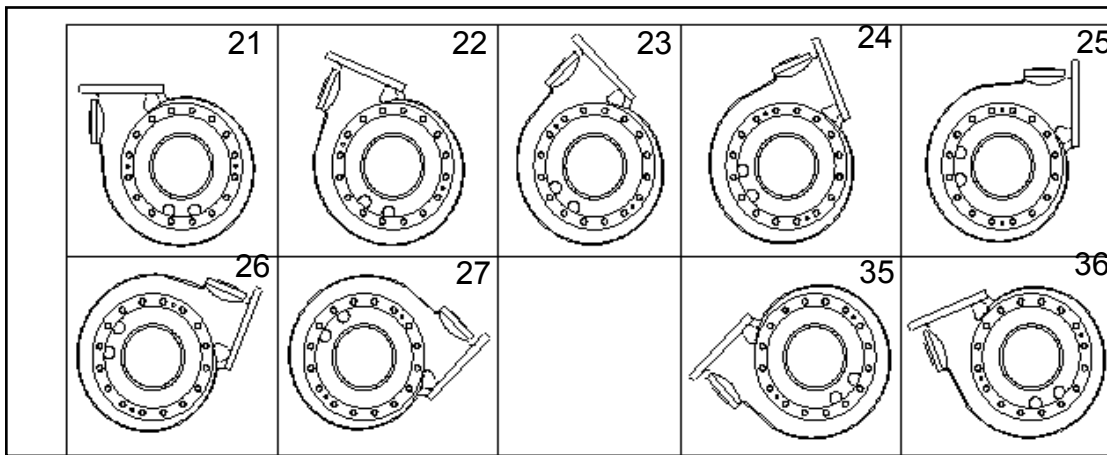

8. Paint Option

DESCRIPTION	PRICE
<input type="checkbox"/> Black Primer	N/C
<input type="checkbox"/> Gray Primer	\$100
<input type="checkbox"/> Hale Black Finish Coat	\$450
<input type="checkbox"/> Hale Red Finish Coat	\$450

9. Pro Tech Warranty (FIRE SERVICE APPLICATIONS ONLY) (NET PRICE, NO DISCOUNTS)

<input type="checkbox"/> Standard 5 Year Warranty (Parts and Labor for the first two years, parts only years 3-5)	N/C
<input type="checkbox"/> Pro Tech Gold Warranty - 1 Additional Year of Labor	\$250
<input type="checkbox"/> Pro Tech Gold Warranty - 2 Additional Years of Labor	\$750
<input type="checkbox"/> Pro Tech Gold Warranty - 3 Additional Years of Labor	\$1500

FOR ADDITIONAL OR LOOSE ACCESSORIES, VALVES, FLANGES, SEE SEPARATE ACCESSORY PAGE PRICE LIST AND ATTACH TO PUMP ORDER



Hale Products, Inc. A Unit of IDEX Corp. 700 Spring Mill Avenue Conshohocken, PA 19428 USA
TEL: 610/825-6300 1-800/220-HALE FAX: 610/825-9615 www.haleproducts.com

Class 1 A Unit of IDEX Corp. 607 NW 27th Avenue Ocala FL 34475 USA
Tel: 352-629-5020 800-533-3569 Fax: 352-629-2902 www.class1.com