

**CUSTOMER ORDER SPECIFICATION FOR HALE 2CBP FIRE PUMP**

Customer Name: \_\_\_\_\_ Customer P.O. NO.: \_\_\_\_\_  
 Order Prepared By: \_\_\_\_\_ Hale Customer NO.: \_\_\_\_\_ Date: \_\_\_\_\_  
 Fire Dept. Name: \_\_\_\_\_ City: \_\_\_\_\_ State: \_\_\_\_\_  
 Requested Delivery Date: \_\_\_\_\_ Max. Elevation for Pump Test: \_\_\_\_\_ FT  
 Reference Specifications: \_\_\_\_\_

Engine: Mfr: \_\_\_\_\_ Model: \_\_\_\_\_ Horsepower: \_\_\_\_\_ @ \_\_\_\_\_ RPM  
 Full Load Governed RPM: \_\_\_\_\_ Peak Torque: \_\_\_\_\_ LB/FT @ \_\_\_\_\_ RPM  
 Application confirmed with: (for applications not on list) \_\_\_\_\_  
 Truck Transmission: Manufacturer: \_\_\_\_\_ Model: \_\_\_\_\_  
 PTO: Model \_\_\_\_\_, % \_\_\_\_\_ Torque Rating \_\_\_\_\_, Rotation \_\_\_\_\_

**1. Pump Model (Circle price of desired model):** \_\_\_\_\_  
**(Hale P/N: 501-6310-00-0): Note: (X) indicates pump ratio selected.**

PUMP MODEL	2CBP(X)	Material
2CBP PTO DRIVE	\$5,855	Cast Iron
2CBPH HYDRAULIC DRIVE	\$7,056	Cast Iron
2CBP PTO DRIVE	CONSULT FACTORY	Bronze
2CBPH HYDRAULIC DRIVE	CONSULT FACTORY	Bronze

**1A. Pump Light Kit Option (Check Applicable Box(es)):**

- NFPA Midship Light Kit \$156
- No Light Kit N/C

**1B. Pump Manual Option (Check Applicable Box(es)):**

- Paper Manual version \$36
- CD Version (2) N/C

**1C. Panel Placard Option (Check Applicable Box(es)):**

- Stamped S/N Placard \$29
- No Panel Placard N/C

**2. Pump Ratio (Circle desired ratio):** N/C

RATIO	MODEL
2.00	2CBP2
2.83	2CBP3
3.94	2CBP4
4.93	2CBP5

**3. Pump Rotation (Check One Box):**

- ENGINE ROTATION N/C
- OPPOSITE ENGINE ROTATION N/C

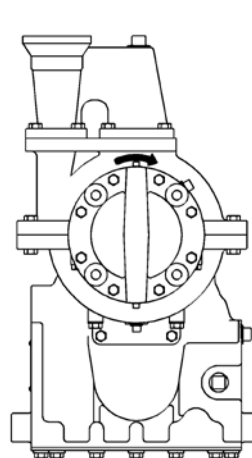

ENGINE ROTATION

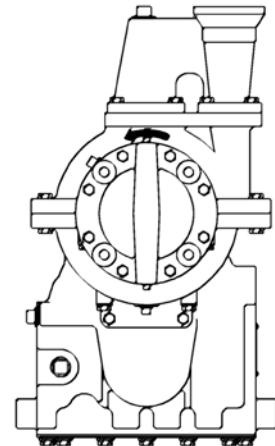

OPPOSITE ENGINE ROTATION

**4. Gearbox Cooler (Check One Box):**

- NONE N/C
- PROVIDED \$ 275

**FOR ADDITIONAL OR LOOSE ACCESSORIES, VALVES, FLANGES, SEE SEPARATE ACCESSORY PAGE PRICE LIST AND ATTACH TO PUMP ORDER**

NOTE: Hale reserves the right to make improvements in design and materials and changes in price without notice  
 ALL PRICES ARE U.S. DOLLARS F.O.B. CONSHOHOCKEN, PA 19428

6. VOLUTE POSITION (Circle Position Desired)

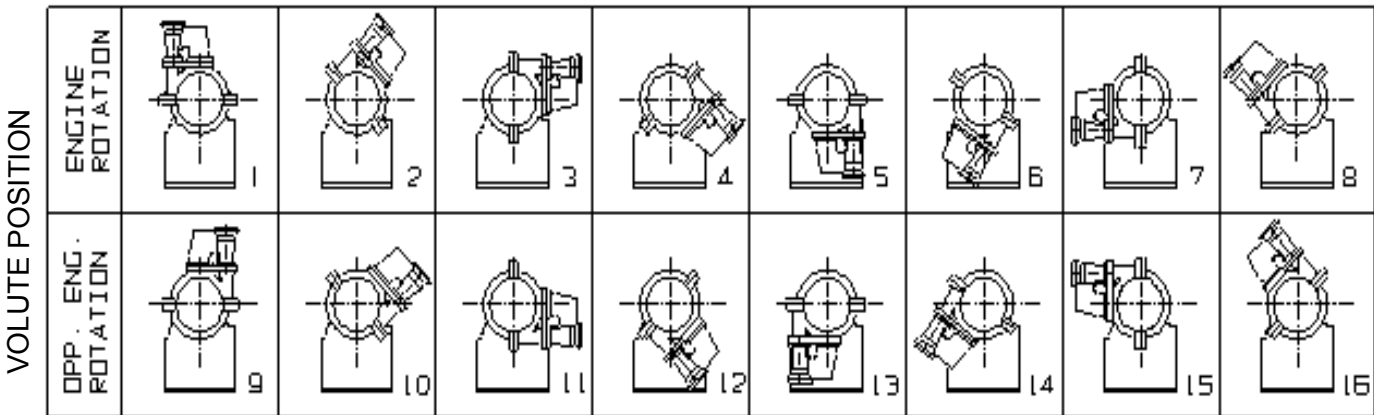

WHEN DISCHARGE POSITION IS NOT SPECIFIED ON ORDER POSITION NO. 1 OR NO. 9 WILL BE SHIPPED DEPENDING ON PUMP ROTATION SELECTED.

7. Pro Tech Warranty (FIRE SERVICE APPLICATIONS ONLY) (NET PRICE, NO DISCOUNTS)

- |                          |  |        |
|--------------------------|--|--------|
| <input type="checkbox"/> | Standard 5 Year Warranty (Parts and Labor for the first two years, parts only years 3-5) | N/C    |
| <input type="checkbox"/> | Pro Tech Gold Warranty - 1 Additional Year of Labor                                      | \$250  |
| <input type="checkbox"/> | Pro Tech Gold Warranty - 2 Additional Years of Labor                                     | \$750  |
| <input type="checkbox"/> | Pro Tech Gold Warranty - 3 Additional Years of Labor                                     | \$1500 |



Hale Products, Inc. A Unit of IDEX Corp. 700 Spring Mill Avenue Conshohocken, PA 19428 USA  
 TEL: 610/825-6300 1-800/220-HALE FAX: 610/825-9615 www.haleproducts.com

Class 1 A Unit of IDEX Corp. 607 NW 27th Avenue Ocala FL 34475 USA  
 Tel: 352-629-5020 800-533-3569 Fax: 352-629-2902 www.class1.com