

**INTERNATIONAL LTD
THERMAL RESEARCH**



Installation and Operating Manual

Oasis[®] Zephyr[™] HW

Diesel Hot Water Heating System



Manual Issue Date/Copyright © September 2013

International Thermal Research

IN CANADA:

2431 Simpson Road

Richmond, BC, Canada V6X 2R2

Tel: 1-800-755-1272 or 604-278-1272

Fax: 604-278-1274

IN THE UNITED STATES:

Suite B, 11915 NE 56th circle

Vancouver, WA USA 98682

Tel:1-800-993-4402 or 360-993-4877

Fax: 360-993-1105

Email: info@itrheat.com

Website: www.itrheat.com

Website: <http://www.itrheat.com> All rights reserved. No part of this manual may be reproduced or transmitted in any form by any means, electronic or mechanical, including photocopying and recording, information storage, retrieval, or transmission, without permission in writing from International Thermal Research

Disclaimer:

Due to our commitment for quality and ongoing product improvement, ITR reserves the right to modify or change without notice, any materials, applications, equipment, accessories, and/or prices. All measurements and weights are approximate.

Read and save these instructions for future reference

Table of Contents

Page	
Section 1, Overview	1-1
1.1 Unpacking the Heating System	1-2
1.2 Protect Your Warranty	1-2
1.3 Heater Features	1-3
1.4 Critical Factors	1-4
1.5 Equipment, Tools, and Skills	1-5
1.6 Testing and Inspection	1-6
Section 2, Mounting the Heater Unit	2-1
2.1 Before You Begin	2-1
2.2 Mounting Location	2-2
2.3 What NOT to Do	2-4
2.4 Installation Procedure	2-4
Section 3, Installing the Exhaust System	3-1
3.1 Before You Begin	3-1
3.2 Mounting Location and Recommendations	3-1
3.3 What NOT to Do	3-3
3.4 Installation Procedure	3-4
Section 4, Installing the Fuel System	4-1
4.1 Before You Begin	4-1
4.2 Fuel System Installation and Recommendations	4-1
4.3 What NOT to Do	4-2
4.4 Installation Procedure	4-3
Section 5, Installing Cabin Fans	5-1
5.1 Before You Begin	5-1
5.2 Fan System Operation; Features; Multi-Zone Heating; Accessories and Components Needed	5-2
5.3 What NOT to Do	5-3
5.4 Mounting Locations	5-5
5.5 Installation Procedure	5-6

Section 6, Wiring the Electrical System		6-1
6.1	Before You Begin	6-1
6.2	Electrical Noise	6-1
6.3	12 VDC.....	6-3
6.4	120/240 VAC Options and Installation Procedure	6-3
6.5	Electrical Components	6-5
6.6	What NOT to DO.....	6-7
6.7	Installation Procedure	6-7
Section 7, Plumbing the System		7-1
7.1	Before You Begin	7-1
7.2	Plumbing Components.....	7-1
7.3	What NOT to Do	7-3
7.4	Installation Procedure	7-4
Section 8, Filling and Testing the Circulation System.....		8-1
8.1	Before You Begin	8-1
8.2	What NOT To Do.....	8-1
8.3	Installation Procedure for Expansion-Tank Filling Method	8-2
8.4	Installation Procedure for Manifold Method.....	8-3
Section 9, Domestic Hot Water Heating		9-1
9.1	Before You Begin	9-1
9.2	Domestic Hot Water System.....	9-2
Section 10, Engine Heat Management.....		10-1
10.1	Engine Waste Heat Function.....	10-1
10.2	Engine Waste Heat Installation Procedure	10-2
10.3	Engine Pre-Heat Function.....	10-2
10.3	Engine Pre-Heat Function Installation Procedure	10-3
Section 11, Operation		11-1
11.1	Starting the Heater	11-1
11.2	Signs of Normal Operation	11-1
11.3	Main Control Board Operation.....	11-2
11.4	Turning Off the Heater (Seasonal)	11-3
11.5	Using the Electric Heating Elements	11-3
11.6	Turning Off the Heater (Maintenance)	11-3
11.7	Resetting a Fault	11-4
Section 12, Troubleshooting		12-1
12.1	Overview	12-1
12.2	Power On	12-1
12.3	Burner On.....	12-1
12.4	Service Switch Off	12-2
12.5	Remote Switch Off	12-2

12.6	Heater Cycling	12-2
12.7	Thermostats Off	12-3
12.8	Voltage Low or High	12-3
12.9	Overheat	12-4
12.10	Fuse Blown.....	12-4
12.11	Fuel Pump/Solenoid.....	12-5
12.12	Ignitor	12-5
12.13	Combustion Fan	12-6
12.14	Water Pump	12-6
12.15	Flame Out	12-6
12.16	Compressor.....	12-8
12.17	Bypass Mode	12-8
12.18	Water Pump On	12-9
12.19	LCD Readout Remote Panel	12-9
12.20	Flame Sensor Module.....	12-9
12.21	Test Points	12-10
12.22	Reduced Output.....	12-11
12.23	Dirty Exhaust	12-11
12.24	Carbon Monoxide Dangers.....	12-12

Section 13, Maintenance **13-1**

13.1	The First Few Weeks.....	13-1
13.2	Coolant.....	13-1
13.3	Nozzle	13-2
13.4	Fuel Lines and Filter	13-3
13.5	Combustion Chamber	13-3
13.6	Hoses and Tubes.....	13-3
13.7	Electrical System.....	13-3
13.8	Recommended Spare Parts	13-4
13.9	Protecting Hydronic Heating Systems.....	13-6

Addendum

Inspection Check Sheet

Warranty Information & Warranty Card

List of Figures

<u>Figure</u>		<u>Page</u>
Figure 1-1	External Dimensions	1-1
Figure 1-2	Typical Series Plumbed Layout	1-6
Figure 2-1	Floor Mount Installation	2-3
Figure 2-2	Heater Mounting Bracket Configuration	2-5
Figure 3-1	Installing the Exhaust System	3-5
Figure 3-2	Installing an Exhaust Goose-Neck System	3-5
Figure 4-1	Fuel Connection Schematic	4-3
Figure 5-1	Wiring the Fan's Aquastat	5-3
Figure 5-2	Mounting a Spacesaver Fan	5-7
Figure 5-3	Installing a Relay for Additional Fan Amperage	5-7
Figure 6-1	Sample Wiring Diagram for Electrical Elements	6-4
Figure 6-2	Wiring a Fan Speed Switch	6-9
Figure 6-3	Wiring Diagram V2001	6-10
Figure 7-1	Three Approved Methods of Installing Heater Hose	7-4
Figure 7-2	Single Loop System, Three Fans, Summer Loop	7-5
Figure 8-1	Filling System Using "Manifold Method"	8-5
Figure 9-1	Single Loop System, Three Fans, Summer Loop	9-2
Figure 10-1	Single Loop System, Three Fans, Summer Loop	10-2
Figure 13-1	Maintenance Schedule	13-5

Overview

Thank you for purchasing the **Oasis® Zephyr™ HW** diesel hot water heating system.

This section describes features of the **Oasis® Zephyr™ HW** heater and explains what to do when you first receive your heater. It also covers critical information you need to know prior to installation, including how to protect your warranty.

Some of the figures in this manual represent a typical installation, but other configurations or methods may be acceptable. If in doubt, contact ITR for assistance.

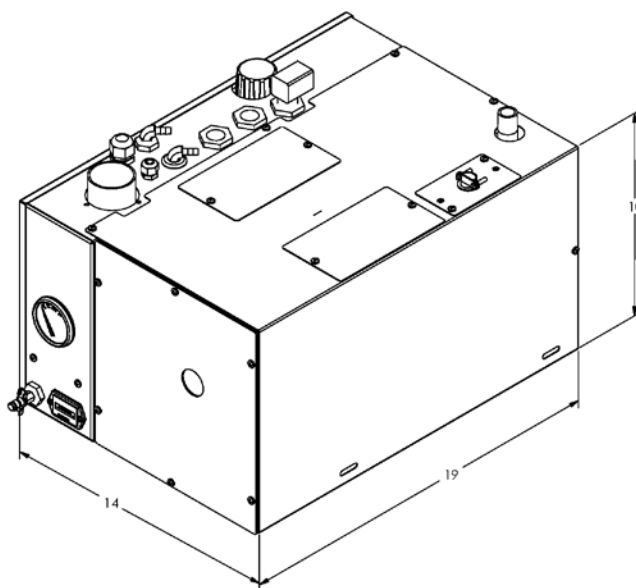

Figure 1-1: Oasis® Zephyr™ HW external dimensions

1.1 Unpacking the Heating System

When you receive your **Oasis® Zephyr™ HW** heater:

1. Unpack it carefully.
2. Check each component against the provided parts list to ensure that you have everything, and that all parts are undamaged.
3. If you discover any missing or defective parts, call ITR immediately.
4. If you are not installing the heater right away, secure all components so none will be misplaced.
5. **Before installing the heater, read the rest of this manual. It contains critical information for a proper installation.**

It's important to follow the installation procedures in this manual to ensure maximum performance of the heater and that you and/or your customers enjoy a warm, comfortable environment and plenty of hot water when needed.

1.2 Protect Your Warranty

This document reflects approved installation techniques, methods, and materials, and applies only to ITR equipment. The heater and supplied components are only guaranteed by ITR if the entire system has been installed according to the requirements and recommendations set forth in this manual.

NOTICE

Warranty coverage will not be extended to ITR heaters and system components used in an improper installation. Use of unapproved materials, equipment, or installation procedures will void the warranty for the entire heating system. ITR does not accept liability for any damage or loss of service resulting from unapproved installations and/or modifications.

1.3 Heater Features

Oasis® Zephyr™ HW ADVANTAGES

- Efficient
- Clean
- Quiet
- Compact
- Safe
- Rugged
- Reliable
- Economical

The **Oasis® Zephyr™ HW** is an advanced hydronic heater with many advantages over forced-air systems. The **Zephyr™** provides space heating using a “heat-transfer fluid” pumped to fan-equipped, radiator-style heat-exchangers. The same “hot” fluid is circulated through an internally mounted, flat-plate heat-exchanger to provide a continuous supply of domestic hot water. The heater runs on 12VDC power, using a diesel fired burner to maintain the temperature of the heater fluid. The **Zephyr™** heater can run waste heat from a vehicle's engine through an internal heat exchanger, and the addition of an optional secondary water pump also allows for pre-heating of the engine.

Other features and benefits of the **Oasis® Zephyr™ HW** heating system include:

- 1500 Watt, 120 VAC (optional 240 VAC) electric element for a supplemental or backup heating source when the vehicle is connected to a power source.
- High-temperature stainless steel burner and water jacket to prevent premature warping or burnout.
- Temperature gauge to measure coolant temperature and indicate when the heater has reached operating temperature.
- Insulated enclosure to retain heat and minimize noise.
- Easy installation and field serviceability, with hookups and connections readily accessible from the top of the heater.
- Quiet operation and low power consumption.
- Low-pressure fuel system with built-in fuel pump.
- Fuel-efficient burner compatible with a wide variety of diesel-based fuels.
- Smoke and smell free exhaust.
- Sealed, fan assisted combustion chamber, designed to use outside air through a direct ventilation hook-up.
- Simple, low amperage draw ignition.
- Return fuel line to eliminate air in the system and prevent nuisance shutdowns.

Section 1, Overview

- Electronically-controlled system with:
 - Automatic safety shutdown.
 - Manual reset overheat temperature sensor and a thermal cutoff for overheat protection.
 - LED display control panel for diagnostics.
 - Patented, proprietary flame sensor
- Remote control panel with on/off reset button, LCD digital readout, and audible alarm.
- Heating control for up to four separate space heating zones, each with its own optional thermostat.
- On demand, continuous domestic water heating without the need for hot water storage.
- Use of engine waste heat to provide system heating.
- Engine pre-heating capabilities (using an optional external pump).

1.4 Critical Factors

Please pay attention to alerts of "Danger" "Warning" "Caution" and "Notice" in this manual.

The key factors to keep in mind when planning and installing the heater are:

- Location restrictions for the heater, electrical control box, and exhaust outlet (to reduce noise, vibration, heat loss, etc.).
- Length, routing, and sizing of the hot fluid lines, fuel lines, air-inlet venting and tubing, exhaust piping, and wiring.
- Outside air - direct, unrestricted air intake requires a draw of outside air for combustion.
- Ability to easily access and service the product, especially fuel, plumbing, and electrical systems.
- System testing and inspection procedures as explained in the supplied inspection check sheets.

1.5 Equipment, Tools, and Skills

If you are the installer, you must be qualified and authorized to perform the installation; this requires mechanical aptitude and electrical knowledge. The installation of the **Oasis@ Zephyr™ HW** shall be in accordance with local regulations and CSA Standard 139. Make sure you comply with existing ABYC/RVIA industry practices, using the highest and most recent standards and codes. Good workmanship is essential. Please refer back to *Section 1.1, Protect Your Warranty*.

You will need the following to install the heating system:

- Standard tools normally available in a well-equipped shop.
- Approved fasteners (used with the supplied mounting hardware) for securely mounting the heater.
- Appropriate exhaust piping that is a maximum of 12' long with no bends.
- Combustion fan intake hose, through-hull adapter, and clamps.
- Exhaust collar.
- Approved 1/4" ID supply and return fuel lines, rubber or copper.
- Enough heater hose to connect the heater to the expansion tank, the expansion tank to the circulation pump, and for appropriate runs to and from each interior fan. If engine waste heat is recycled into the system, heater hose is required to connect the heater to the engine block.
- Clamps to secure all heater hose and fuel hose connections.
- Expansion tank and radiator cap with a maximum pressure relief of 7 lbs.
- Overflow tank to connect to expansion tank, with clear plastic 3/8" ID hose. Tank must be heavy-duty plastic, with a screw-down cap, and sturdy enough to mount firmly to a vertical surface.
- DC compatible thermostat(s) for temperature regulation of each interior heating zone (up to 4).

Section 1, Overview

- A container to fill the system with fluid after installation.
- Cabin fans or passive radiators to distribute heat to interior heating zones.

See *Figure 1-2* for a typical series plumbed layout using the **Oasis® Zephyr™ HW** heater.

1.6 Testing and Inspection

After all components have been properly installed according to standard practices and the recommendations of this manual, the heating system should be test-operated and inspected.

For your convenience, you can use the pullout *Inspection Check Sheet* in this manual. The check sheet is divided into stages, allowing each phase of the inspection to be carried out systematically.

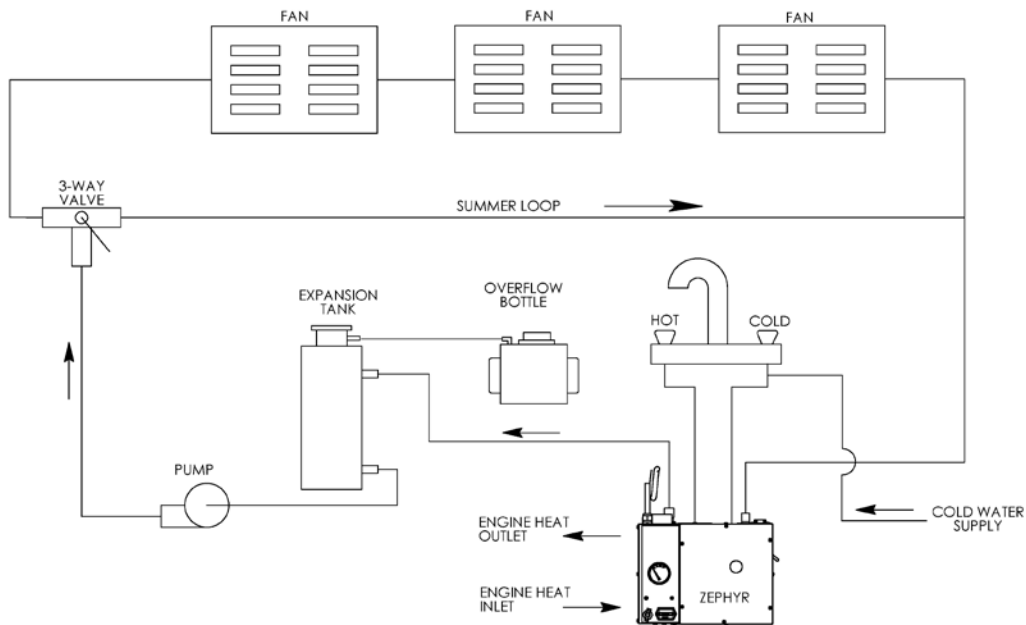

Figure 1-2: Typical Zephyr system series layout, with three cabin fans and optional summer loop.

Mounting the Heater Unit



2.1 Before You Begin

Plan the location of the heater and all its major components in advance to ensure the chosen locations are appropriate and within technical specifications.

Consider the following factors to help you decide exactly where to mount the heating system:

- Heater weight when full.
- Ventilation requirements.
- Exhaust outlet location and maximum acceptable exhaust length.
- Potential for vibration and jarring.
- Fuel storage location.
- Most efficient plumbing runs.
- Safe and convenient access for maintenance.
- Number and location of interior fans.
- Location of other equipment to be installed or connected to the heater, including control box, expansion tank, overflow bottle and circulation pump. Note: the circulation pump must be mounted in a location that is below the expansion tank.

! WARNING

Make sure you are familiar with *Section 1, Overview* of this manual. If the system is not installed according to specifications and with the correct equipment, your heater may not operate properly, safety may be compromised, and your warranty may be voided.



2.2 Mounting Location

- Mounting location must be able to support double the gross weight of the heater when full (i.e. 70 lbs x 2 = 140 lbs/63.5 kg).
- The **Oasis® Zephyr™ HW** model is 10.5"H x 14"W x 19"D (26.6 cm x 35.5 cm x 48.2 cm). (See *Figure 1-1*)

! DANGER

The Oasis® Zephyr™ HW heater must not be installed in any compartment with flammable gases.

- The **Oasis® Zephyr™ HW** heater must be isolated completely from all living spaces. Combustion air must be drawn directly from an outside source and cannot contain any combustible gases. Use the supplied air intake hose (part# 8019) and the aluminum air intake collar (part# 10089). Securely clamp and seal all air inlet hose connections. Ensure the supply of combustion air to the heater is not obstructed or cut off.
- The heater must be mounted in an area that provides unrestricted access to the front panel and left-side panel, as well as access to fuel, water, power and exhaust connections. There should be at least 8" of clearance on the left side of the heater for accessing and servicing the components in the mechanical box, 9" of clearance to the front of the heater for accessing and servicing the burner, and 3" of clearance to the top of the heater for accessing fittings and aquastats. The right side and back side of the heater do not require clearance. The heater can be installed in a location that allows accessibility to the front and side service panels through access panels. It must, however, be possible to completely remove and replace the heater's service panels in order to properly service and maintain the heater.
- The heater must not be installed in any compartment with flammable gases.
- The heater must be mounted horizontally and must be level. It must be mounted using the supplied mounting brackets with fitted rubber grommets. These brackets fit through the slots on the bottom right side of the heater and are secured to the mounting surface with appropriate fasteners, fender washers and lock washers. The heater is secured the same way on the left side. The mounting holes are located on the bottom of the heater inside the left service panel. (See *Figure 2-2*).

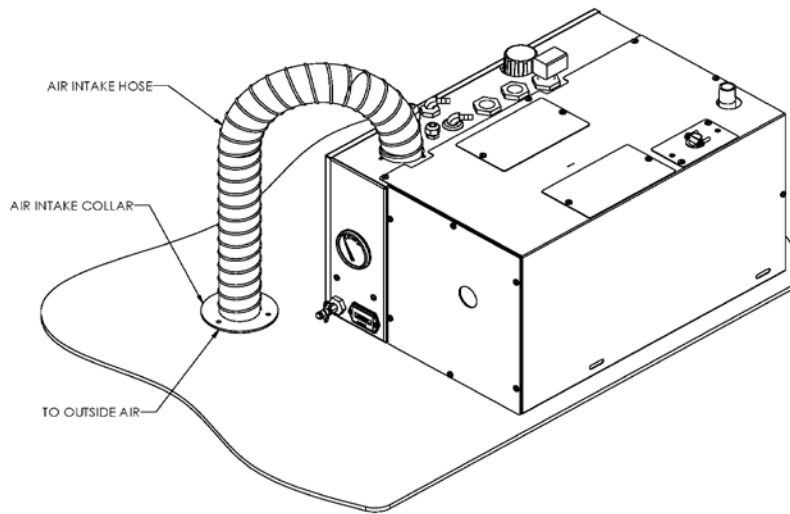

Figure2-1: Oasis® Zephyr™ HW typical floor mount installation showing dedicated fresh-air intake.

WARNING

If The **Oasis® Zephyr™ HW** is going to be mounted in the engine compartment, check for adequate ventilation. Make sure there are no exhaust leaks and that all exhaust fittings are well-fastened to the heater and the muffler. Any assembly parts that may cause injury through accidental contact should be protected. Isolate the unit in a closed compartment so that no exhaust from the heater will infiltrate interior living spaces.

- Choose a sturdy surface in a location that won't be unduly affected by vibration or jarring.
- Mount the unit with the front side panel and left side panel facing out and accessible. Facing out simplifies installation, maintenance and servicing. If the heater is mounted in a location without removable access panels, there must be a minimum of 9" of accessibility to the front of the heater, and at least 8" of accessibility on the left of the heater, to allow for the removal service panels.
- Ensure that exhaust tubing can be properly and safely routed outside the vehicle. The maximum exhaust run for the system is 12' without 90° bends.

2.3 What NOT to Do



Don't mount the heater without a direct connection to the combustion fan from an outside air source.

Don't mount the heater without the supplied exhaust fittings installed and the exhaust directed out from under the vehicle.

Don't mount the heater in a location that restricts access to service panels or creates interference with top mounted connections.



2.4 Installation Procedure

After choosing the mounting location for the **Zephyr**:

- 1 Make sure the thru-hole exhaust ring is secured in-place. Place a bead of heat-rated sealant around the top edge of the exhaust ring. Place the heater COMPLETELY over the exhaust ring so the exhaust outlet of the heater is as close as possible to being centered within the exhaust ring. Make sure the heater is horizontal and level.
- 2 Secure the heater on both sides. Use appropriate fasteners, the supplied mounting brackets with fitted rubber grommets, fender washers, and lock washers. (See *Figure 2-2*).

WARNING

The **Oasis® Zephyr™ HW** must be mounted (with a sealant) completely over the thru-hole exhaust ring! Outside air must not be allowed to enter the vehicle through the exhaust thru-hole.

Section 2, Mounting the Heater Unit

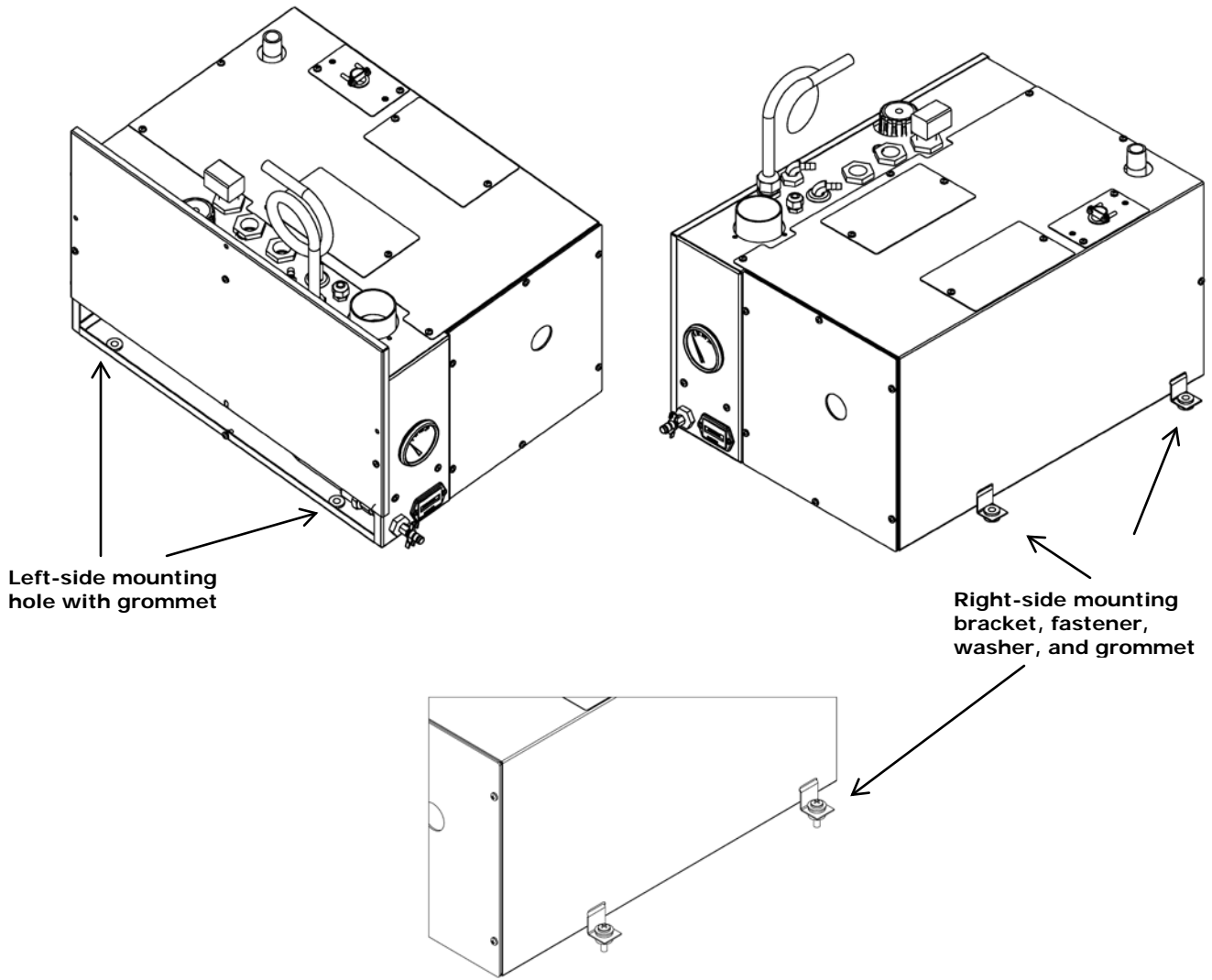

Figure 2-2: Heater Mounting Bracket Configuration

Installing the Exhaust System



3.1 Before You Begin

For efficient and safe operation of the Oasis® Zephyr™ HW follow all recommendations for properly installing the exhaust. Any deviations from these recommendations must be approved in advance by ITR.

! DANGER

Although the heater's exhaust produces very low carbon monoxide emissions, caution is advised:

- Do not operate the Oasis® Zephyr™ HW in an enclosed area unless there is adequate ventilation.
- Isolate the Oasis® Zephyr™ HW in a closed compartment so that no air from the unit will infiltrate vehicle living areas.

Never place any exhaust parts close to combustible material or through a combustible wall or ceiling without fireproof protection. The exhaust can reach high temperatures. Heater exhaust must be ducted to the outside of the vehicle.

3.2 Mounting Location

If you can't meet the technical specifications for mounting the exhaust, don't use the Oasis® Zephyr™ HW. The heater may perform poorly or become damaged if not installed according to specifications.



Recommended Exhaust Outlet Locations

The following are recommended for coach exhaust outlet locations:

- Mount the exhaust outlet **outside** the coach, not inside the heater compartment. Otherwise, exhaust fumes could infiltrate the vehicle.

- In a coach, the typical mounting location for the exhaust outlet is under the floor of the **Oasis® Zephyr™ HW** compartment, or on the other side of the coach, directly across from the heater. Keep in mind you cannot exceed 12' of exhaust piping without any bends, or 8' with two 90°, 2" minimum radius bends.
- Position the outlet of the exhaust pipe so the exhaust exits off the side of the coach, not directly underneath the coach or under an opening window, a vent or a slide-out.



Recommendation for Installation

- You may use sweep bends, but each 90° bend is equivalent to two feet of exhaust piping. For example, if you use two 90° bends you must deduct two feet per bend from the maximum allowed 12' straight exhaust pipe length. Therefore you will be restricted to 8' of straight exhaust piping if you include two bends.
- Combustion air must be drawn directly from outside the vehicle using the supplied air intake hose.
- Use an ITR-manufactured muffler (part# 10282) with a straight-through design. No other muffler is acceptable.

! DANGER

The exhaust and outlet are HOT and the surrounding areas must be thermally shielded and protected from hot surfaces and heat build-up. Nothing can come into inadvertent contact with any part of the exhaust system.

- The exhaust must have a minimum of 3" (7.6 cm) clearance from all surfaces.
- Ensure that the exhaust cannot be plugged or restricted.
- The **Oasis® Zephyr™ HW** is supplied with a 3" x 1.25" MPT nipple (part# 2342) that is threaded into the exhaust outlet. A 1.25" FPT elbow is attached to the nipple. The supplied muffler is threaded into this elbow. Any exhaust fittings extending this assembly must have a minimum of 1.25" ID throughout their length. (see *Figure 3.1*)
- The supplied exhaust elbow (part# 2337) is 1.25" FPT. Any aftermarket elbows used must be the same thread and must be of large radius design.

- The exhaust must be supported at least every 3' of its installed length.
- All non-threaded exhaust connection points must use appropriate clamps to ensure that connections are tight and leak free. A small amount of sealing compound may be used in conjunction with clamps, but do not overuse sealing compound, as it can clog the exhaust. The **Oasis® Zephyr HW** heating system exhaust outlet pipe, and the exhaust pipe itself, must not be distorted or damaged during this process.
- When the **Oasis® Zephyr™ HW** is running, the connection points and the system must be checked for leaks. Any leaks found must be corrected. Periodically, check the exhaust fittings, connections, exhaust tube, and insulation for leaks and integrity, and correct if required.
- Appropriate exhaust insulation must be used to cover the entire length of any interior exhaust run.
- Solid steel exhaust tubing or other approved exhaust tubing is recommended. Stepped band clamps are recommended for joining the tubing as they apply firm, even pressure.
- Install an exhaust collar on the exhaust pipe to isolate the pipe from the coach frame. This reduces vibration and noise and protects the coach from the effects of high exhaust temperature. (See *Figure 3-1*).

3.3 What NOT to DO

Don't mount the exhaust pipe inside the heater compartment.

Don't use more than 8' of exhaust pipe if 180° of total bends are present.

Don't use any mufflers not supplied or approved by ITR.



3.4 Installation Procedure

Figure 3-1: Installing the Exhaust System shows a standard setup for the exhaust. To install the exhaust system:

- 1 Leave suitable air spacing to protect combustible materials. Use an exhaust collar and metal shields where required.
- 2 Find an appropriate location for the exhaust hole of the heater. (See *Figure 3-1*)
- 3 Securely screw the exhaust piping to the **Oasis® Zephyr™ HW** fitting using approved sealant.
- 4 Connect the exhaust piping in series with the muffler, using heavy-duty exhaust clamps. If you use vibration isolation mounts they must be rated for high temperature.
- 5 Connect the flexible 2" ID air-intake tubing (part# 8019) to the air-intake fitting on top of the heater. Use a #32 gear clamp to attach the tubing to this fitting. The other end of the air-intake hose can be installed in 2 configurations as explained below.
- 6 Find a suitable location to mount the air-intake adapter (part# 10089). Drill a 2" hole through the floor. Insert the adapter from underneath and use 3 screws to secure against floor. Use a #32 gear clamp to attach the tubing to this adapter. Ensure the run of tubing is as short as possible to facilitate air flow. (See *Figure 3-1*)
- 7 Secure both ends of the air-intake tubing with properly sized hose clamps to prevent air leaks.
- 8 Make sure the air-intake and exhaust hoses have no leaks and are not touching each other.
- 9 If necessary, protect the air-intake entrance from water and dirt with a guard or shield.
- 10 If installing the **Zephyr** on a yacht, use a dual thru-hull adapter (part# 5158) and make sure it is at least 30" above the waterline. The exhaust must be goose-necked. (See *Figure 3-2*)

Section 3, Installing the Exhaust System

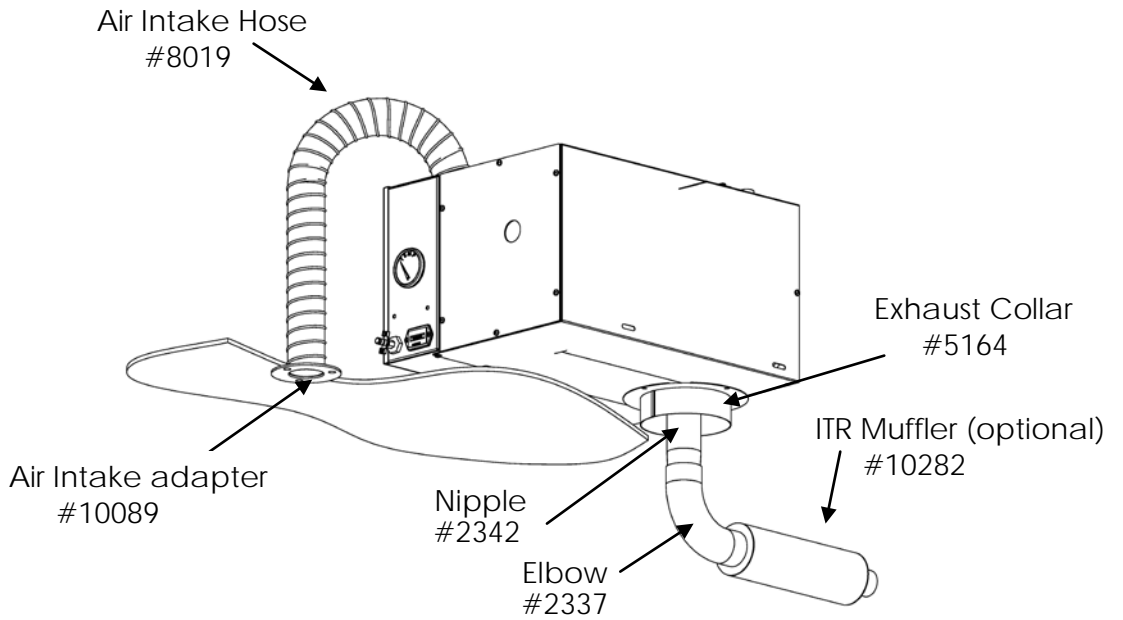

Figure 3-1: Installing the Exhaust System

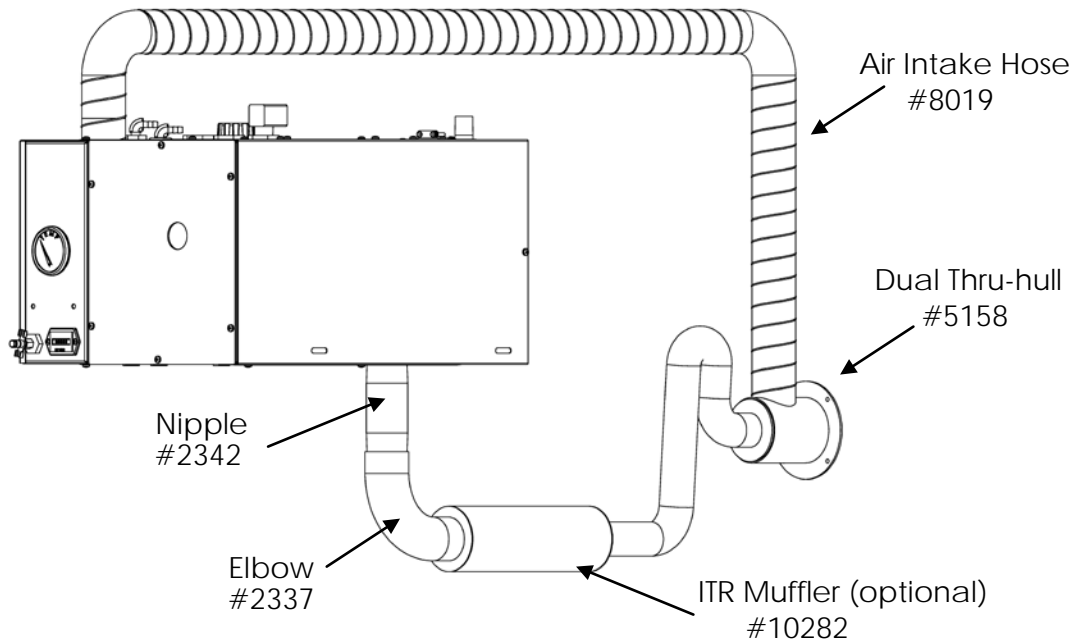
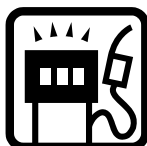

Figure 3-2: Installing a Marine Exhaust Goose Neck System

Installing the Fuel System



4.1 Before You Begin

For efficient and safe operation of the **Oasis® Zephyr™ HW**, follow all recommendations for properly installing the fuel system. Any deviations from these recommendations must be approved by ITR.

! DANGER

Although the **Oasis® Zephyr™ HW** is compatible with furnace oil, stove oil, Biodiesel 20 and jet fuel, it is only certified for use with diesel #1 and #2. **DO NOT USE GASOLINE, CRANKCASE OIL, OR ANY OIL CONTAINING GASOLINE.**

Keep fuel lines away from any heat source above 100°F (38°C).

Keep gasoline and any equipment that uses gasoline away from the **Oasis® Zephyr™ HW** location. **The Oasis® Zephyr™ HW** is not rated for use in a flammable environment.

! WARNING

Never share the fuel supply line of the **Oasis® Zephyr™ HW** with any other fuel-burning device.

4.2 Fuel System Installation

The fuel pump in the **Oasis® Zephyr™ HW** has a maximum flow capacity of 25 gallon/hr and a maximum flow pressure of 11.5 psi. A 10 micron fuel filter is recommended. Select a fuel filter based on these requirements.



Recommendations for Installation

The **Oasis® Zephyr™ HW**'s fuel connections are accessed from the top of the heater. Both 1/4" hose barb connections are located on the top left of the **Zephyr™** and are labelled "inlet" and "return". The minimum recommended size for the fuel line is 1/4" I.D. The fuel return line should connect to the fuel supply tank.

The following are recommended for fuel system installation:

NOTICE

The fuel supply line from the fuel tank to the heater fuel inlet must originate from a dedicated fuel pickup.

- The fuel supply line should be installed with minimal rise from the fuel tank. The total rise from the bottom of the pickup tube to the fuel inlet on the **Oasis® Zephyr™ HW** should not exceed 60". There are no minimum clearance requirements between the fuel tank and the **Oasis® Zephyr™ HW**.

! CAUTION

The fuel line must be secured throughout its run, to prevent damage from rubbing, chafing and kinking during normal operation.

- All fuel line connection points and hoses must use suitable clamps and must be checked for leaks upon installation. They must also be checked periodically as part of normal maintenance. Constant tension spring clamps are recommended for these connection points.
- A primary, UL and/or CSA approved fuel oil filter (not provided) must be installed on the supply line between the fuel tank and the **Oasis® Zephyr™ HW**, in a manner that ensures easy access for maintenance. All filters must be replaced as part of normal maintenance.
- Fuel line hose must have a minimum rating of SAE 30R7, appropriate for use with the fuels listed above.



4.3 What NOT to Do

- **Don't** allow the fuel or fuel lines to become contaminated with foreign material.
- **Don't** allow fuel lines to become damaged or constricted.

! CAUTION

Ensure that fuel lines are always protected from contamination by foreign material. When installing or servicing, seal off ends to prevent contamination. After installing, you may also wish to flush the fuel line to rid of it of air or any foreign material.



4.4 Installation Procedure

To complete the fuel system installation:

- 1 Install an inline fuel filter. The optimal fuel filter location is on a compartment wall next to the **Oasis® Zephyr™ HW**, inline between the fuel tank and the heater.
- 2 Connect the fuel line from the inlet side of the filter to the dedicated pick-up on the main diesel fuel tank.
- 3 Inspect the supply fuel line for any loose connections or damage. Fittings must be secure and airtight.
- 4 Install a shut-off valve between the filter and the fuel inlet of the heater and, if desired, on the tank side of the fuel filter to allow fuel supply shut off and filter replacement. (See *Figure 4-1*)
- 5 Install a fuel line from the fuel return of the heater to the top of the fuel tank. This line will allow air within the fuel lines to be purged from the system.

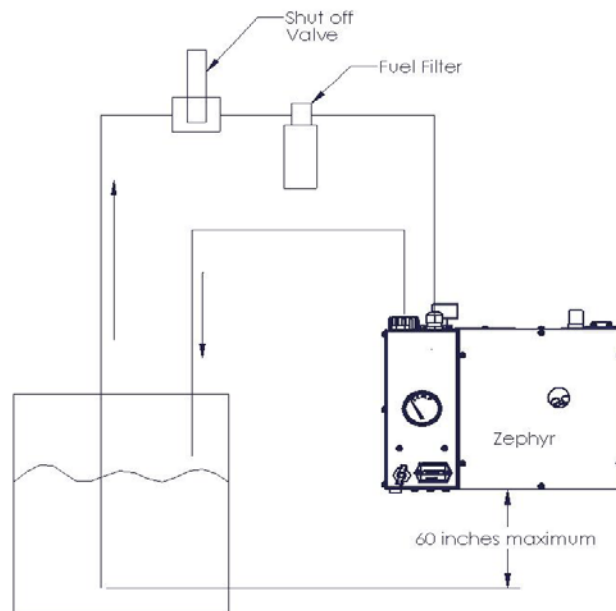

Figure 4-1: Fuel Connection Schematic

Installing Cabin Fans



5.1 Before You Begin

ITR makes the following cabin fans for space heating and individual cabin heating:



Standard Cabin Fan (Part No. 6002)

- Dimensions: 10" Wide 6" High 6.75" Deep
- Power Requirement: 0.9 Amp @ 12VDC
- Output: 8,700 BTU/h @ 120F and 3.0 GPM
- Connections: 3/4" Hose
- Construction: Stainless Steel Case



High Output Cabin Fan (Part No. 6093)

- Dimensions: 10" Wide 6" High 6.75" Deep
- Power Requirement: 1.6 Amp @ 12VDC
- Output: 12,000 BTU/h @ 120F and 3.0 GPM
- Connections: 3/4" Hose
- Construction: Stainless Steel Case



Small Case Defroster Fan (Part No. 6048)

- Dimensions: 10" Wide 6.0" High 9.5" Deep
- Power Requirement: 10.5 Amp @ 12VDC on High
- Output: 16,000 BTU/h @ 120F and 3.0 GPM on High
- Connections: 3/4" Hose
- Construction: Stainless Steel Case



Low Profile Galvanized Cabin Fan (Part No. 6094)

- Dimensions: 13.25" Wide 4.5" High 8" Deep
- Power Requirement: 1 Amp @ 12VDC
- Output: 6,000 BTU/h @ 120F and 3.0 GPM
- Connections: 3/4" Hose
- Construction: Galvanized Case



Small Space Galvanized Cabin Fan (Part No. 6095)

- Dimensions: 9.0" Wide 5.5" High 5.0" Deep
- Power Requirement: 0.5 Amp @ 12VDC
- Output: 4,000 BTU/h @ 120F and 3.0 GPM
- Connections: 3/4" Hose
- Construction: Galvanized Case

Low Profile Dual Fan Defrost Heater (Part No. 6096)

- Dimensions: 15.5" Wide 6.0" High 13.0" Deep
- Power Requirement: 9.8 Amp @ 12VDC on High
- Output: 20,000 BTU/h @ 120F and 3.0 GPM on High
- Connections: 3/4" Hose
- Construction: Plastic Case

NOTICE

Only the installation of ITR cabin fans is covered in this manual. If you are installing non-ITR cabin fans, you must obtain prior approval from ITR. You must check the fans' total amperage draw to ensure they will be compatible with the Zone Control Board. You must also check flow capacity, to ensure that each non-ITR fan meets system requirements.

5.2 Fan System Operation

ITR fans consist of a 12 VDC brushless fan and heater coil, similar to those found in a radiator.

When the heater unit comes on, the fan draws ambient air from the vehicle interior, blows it through the heater coil and back into the interior through a vent. There must be an input and output vent for each fan unit.

Features

ITR heater fans can be supplied with a built-in temperature sensor (aquastat), which prevents fan operation until the system has reached a minimum operating temperature.

Section 5, Installing Fan Heaters

Installation of aquastats on the fans is necessary to prevent cold air from being blown out of the cabin fans during the brief period that it takes the heated coolant to travel from the tank to the cabin fans. *Figure 5-1* shows how to wire the aquastat.

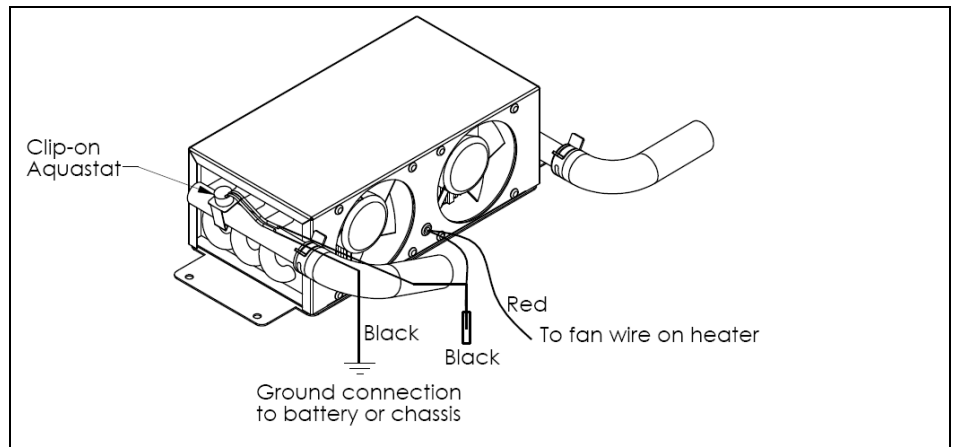

Figure 5-1: Wiring the Fan's Aquastat

If a "passive" radiant heat system is desired (i.e. baseboard or fin and tube configurations), consult ITR for recommended installation procedures and design.

Multiple Zone Heating

Up to four thermostats (positive DC compatible) can be installed to allow separate temperature regulation of the four zones. Each zone has a maximum rating of 5 amps, and all of the zones together cannot exceed a total of 10 amps. Note: A typical external pump in the system will draw 2.5 amps. If a larger pump is used, the maximum current rating cannot exceed 10 amps.

For larger installations, contact ITR.

Accessories and Components

ITR supplies a variety of accessories that can be introduced to the system during installation. These can be purchased separately as needed. Some of the most commonly used items are:

- **Thermostats** — installed in the vehicle's interior for each individual heating zone (up to 4 for the **Oasis® Zephyr™ HW**).
- **Air Outlet Vents** — covers that are installed flush to an interior wall.
- **Fan Guards** — to protect the fan blades from damage. Recommended for fans installed in storage areas or other accessible areas where something could contact the fans.
- **Two-Speed Fan Switches** — to allow low and high-speed setting control from inside the vehicle. For use with a variety of ITR cabin fans.
- **Three-Speed Fan Switches** — to enable low, medium and high-speed settings from inside the vehicle. For use with ITR defrost heaters.
- **Air Ducting** — to allow installation of fans in remote locations (i.e. not directly adjacent to the interior space to be heated). Heated air is ducted to output locations.
- **Air outlet plates** - to allow ducting for one, two or three separate outlets (e.g. use one fan to heat two different areas by installing a dual air outlet plate).



5.3 What NOT to Do

- **Don't** install fans that require more BTUs than the **Oasis® Zephyr™ HW** can produce, or the system will not operate effectively.
- **Don't** mount the return air outlet too close to the fan's air intake source.



5.4 Mounting Locations

Carefully choose the mounting locations of your fans:

- Locate the fans to evenly heat the desired area.
- Provisions must be made to protect water lines from freezing.
- Install fans at floor level or very near floor level, in order to optimize circulation.
- Allow a minimum 16 square inch (100 cm sq.) opening in the fan heaters' mounting compartment to allow sufficient intake of air.

ITR can suggest optimal fan locations if you provide a floor plan of your vehicle.

ITR's cabin heater fans can be mounted on the floor or on the wall, either flat or on their side.

The thermostat(s) should be mounted on an interior wall or bulkhead, away from windows, heater vents, and cabin fan heaters. This will avoid an inaccurate reading of the actual zone temperature.



5.5 Installation Procedure

After choosing the appropriate mounting location and configuration:

- 1** Mount the fan using appropriate sheet metal screws or wood screws. (See *Figure 5-2*.)
- 2** If you are using ducting and a dual air outlet plate for any fan, limit the total length of duct for both outlets to 36" for optimum air output.
- 3** Select the appropriate mounting location for the thermostat(s), as well as any fan speed switches. See *Section 6- Electrical Systems* for wiring thermostats to the **Zephyr™** control board.
- 4** The **Zephyr™** zone board allows a cumulative draw of 18 amps, including external pumps. If an individual cabin fan draw is larger than the 5 amp limit, you must install a separate relay to power the fan. This relay will use the existing fan circuit as a signal and must be wired to a secondary power source (fused from the positive battery terminal), and not from the power to the heater's control board. (See *Figure 5-3*.)
- 5** To install plumbing lines to the fans, see *Section 7 – Plumbing the System*.

Section 5, Installing Fan Heaters

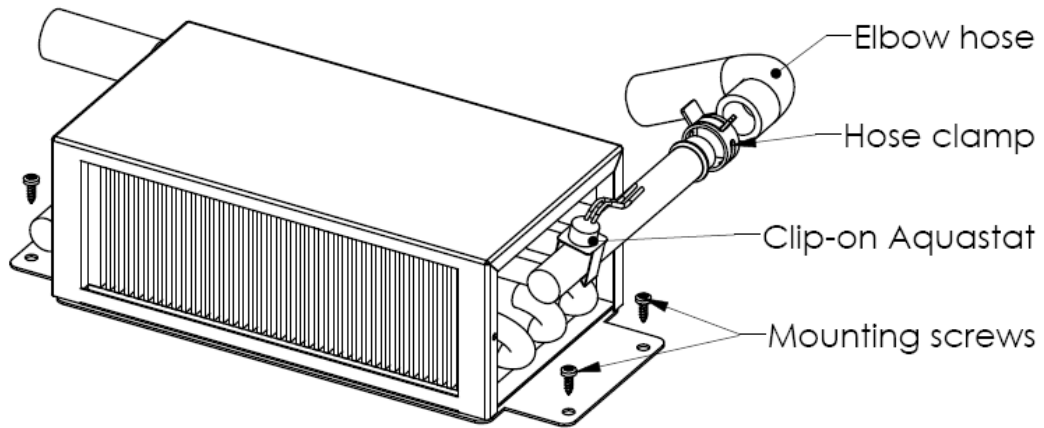

Figure 5-2: Mounting a SpaceSaver Fan

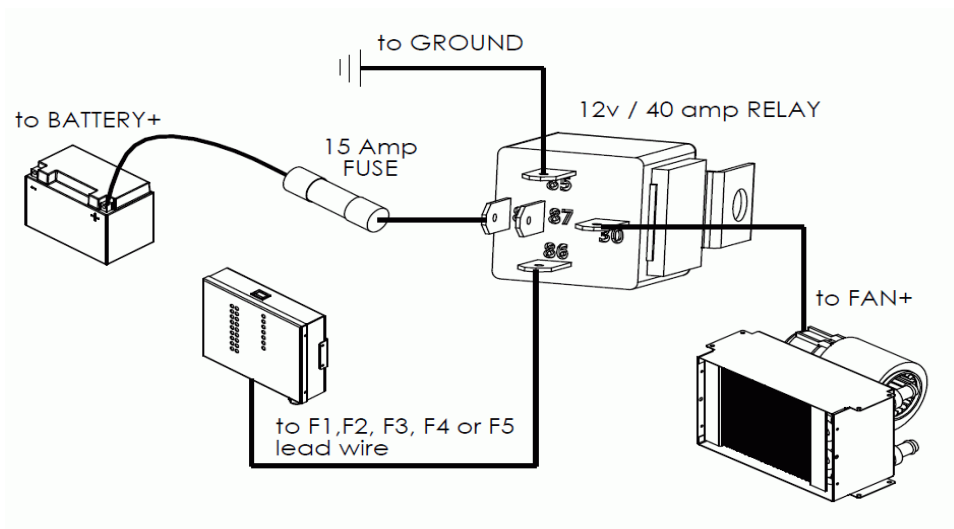

Figure 5-3: Installing a Relay for Additional Fan Amperage

Wiring the Electrical System



6.1 Before You Begin

The heater and its electrical control board are pre-wired and have been thoroughly tested together as a unit.

To review the wiring system for the entire heating system, refer to the schematic at the end of this section (*Figure 6-3*).

! WARNING

All electrical connections and wiring must comply with normally-accepted 12 VDC and 120VAC (North America)/240 VAC (Europe) wiring practices, local regulations, and ABYC /RVIA standards. Only a qualified electrical installer should complete the wiring. All field wiring is to be in accordance with CSA Standard C22.1, Canadian Electrical Code Part I or the National Electric Code.

6.2 Electrical Noise

Electrical noise is an unwanted electrical signal which produces undesirable effects in the circuits of the control system.

Most electronic noise stems from crude wiring practices, which allow "coupling" (the transfer of electrical noise into the control circuit from the noise source). Erratic, intermittent, and inconsistent system behaviour often suggests electrical signal interference, and can be difficult to diagnose. Lower power level controllers that use electronic logic, especially those using integrated circuits, are especially sensitive to electronic noise.

A typical electronic noise source is any piece of equipment that can cause changes in voltage or current when turned ON and OFF. A single side-band transmitter is an example of this type of equipment.

Common electronic noise sources:

- Loose connections
- Switches and relay contacts operating inductive loads, such as motors, coils, solenoids, and relays etc.
- Welding machinery
- Heavy current carrying conductors
- Fluorescent and neon lights

Sensor input and power output lines, as well as the power source line, all have the potential to couple the control circuit to a noise source.

"Common Impedance Coupling" occurs when two circuits share a common conductor. Avoid running multiple loads or return lines on one conductor. Use independent leads for each return circuit, and terminate all return circuits at the same physical point.

"Magnetic (Inductive) Coupling" generally appears when there are wires running parallel, or in close vicinity to, each other. This is especially prevalent when the wires from several circuits are bundled together in order to make the system wiring appear neat.

"Electrostatic (Capacitive) Coupling" is a function of the distance wires run parallel with each other, the distance between the wires, and the diameter of the wire. The best way to eliminate Electrostatic Capacitive Coupling is to run separate leads from separate circuits in separate bundles, taking special care to keep AC (high power lead) wires separated from DC (low power level) wires. If possible, twisted lead pairs and shielded cables should be used. Note: special attention should be given to AC power lines, because they are a source of unusual types of noise-related problems in control circuits.

"Electromagnetic (Radiation) Coupling" occurs when the control circuit is very close to a high-energy source that is capable of magnetic or electrostatic induction of a voltage. A common source of such radiation is an inverter, alternator, generator, motor transformers, fluorescent lights, radio, TV, and navigation equipment.

6.3 12 VDC

The following applies to the 12VDC power supplied to the heater:

- There is one electrical terminal on the main control board for the primary 12 VDC positive (red) and negative (black) power. There are no direct 12 VDC power connections to the heater itself.

! WARNING

Primary DC power should originate from a dedicated connection on the house battery bank. A 25 amp fuse or breaker must be included inline from the battery to the positive connection on the control board. The primary power wire gauge must be sized to permit no more than a 3% voltage drop from the battery to the heater.

- There are no switches on the control board or box that disconnect the power to the heater and/or control board once 12 VDC power has been supplied to the board.
- A properly-shielded power system is required for safe, trouble-free operation.

6.4 120/240 VAC

- **The Oasis® Zephyr™ HW** is equipped with one 1500 Watt 120 VAC (North America) electric heating element or one 1500 Watt 240 VAC (Europe) electric heating element (optional). The connections for the electrical supply are on the top right side of the heater, under a cover.
- The power wires for the heating elements are three 14 gauge stranded copper leads that use standard AC color code (black – hot, white – neutral, green/yellow – ground). They are to be connected using standard 120/240 VAC electrical connectors and terminals. The wires are to be connected to a switch, and from there to a separate AC circuit breaker. Once the connection is completed, the wires are to be inserted back into their compartment and the cover secured.
- The electrical heating element is operated independently from the control board. It is best to wire the element to a separate switch with indicator light to see when the element is activated. (See *Figure 6-1*).

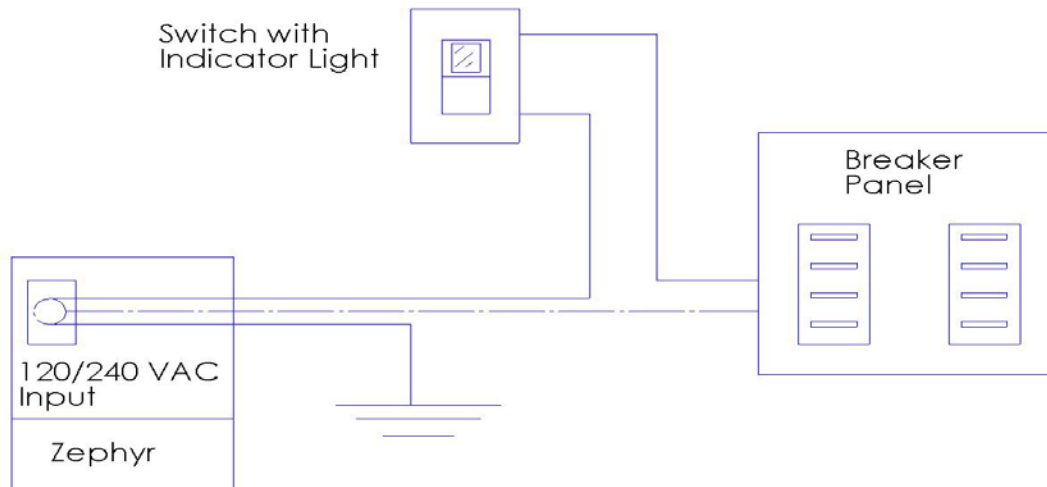

Figure 6-1: Sample Wiring Diagram for Electrical Elements

- To circulate heated coolant when only the Electric heating element is being used, a separate switch must be used.

Note: The electric element provides approximately 5100 BTUs and is a supplemental heat source that can be used on its own or in conjunction with the burner. It's heating capabilities are limited and will not provide the same heating performance as the diesel burner.

Installation Procedure



To use only the electric heating element:

- 1** Install a switch and wire to the A1 terminal on the main control board and the battery negative terminal. This will be wired in parallel to the wire already connected to the A1 terminal.
- 2** Turn ON the switch shown in *Figure 6-1*. This will activate the electric heating element and will heat coolant inside the tank.
- 3** To use the heated coolant inside of the tank, turn on the switch that is wired to the A1 terminal (Step 1). The circulating pump will turn on and circulate the heated coolant when there is a call for heat from thermostats or domestic water.
- 4** The circulating pump will continue to operate until either the switch wired to the A1 terminal is turned off, or there is no longer a call for heat.

NOTICE

During installation or servicing, or if coolant is low, do not operate the electric element until coolant is added to the heater and all trapped air has been removed from the system.

6.5 Electrical Components

- **Control Box and Board** – The main control board is contained in a stainless steel control box and is connected to the heater via a 12' long, 1/2" diameter interface cable. All components in the heater unit are pre-wired through the interface cable to the main terminal block on the control board. (See *Figure 6-3*.)
- **Fuses** – The control board contains four fuse holders with fuses pre-installed. These are standard, automotive, spade type fuses available from most auto parts stores.
- **Thermal Cutoff** - The heater burner box contains a non-resettable thermal cut-off that will provide protection against an overheat condition within the burner box. If activated, the thermal cut-off is designed to stop fuel flow to the burner nozzle.
- **Accessory Terminal Block** – The following components need to be wired into the accessory terminal block on the control board:
 - Cabin fan heaters
 - Fan speed switches (if any)
 - Circulation pump
 - Domestic water aquastat
 - Engine-heat aquastat
- **Fault Bypass and Reset Buttons** – These buttons allow testing of the heating system by bypassing the fault-sensing circuit. This fault bypass feature is engaged by depressing and holding the top button, depressing and releasing the bottom button, and then releasing the top button. To reset the heater, turn the heater service switch OFF, then ON again.

! WARNING

Do not leave heater running unattended in bypass mode. Bypass mode runs for five (5) minutes.

- **Test Points** – These points on the control board allow troubleshooting of the heating system. For detailed information on the use of each test point, see *Section 12.10 - Test Points*.
- **Diagnostic Display** – An LED indicator for diagnostics of the heater. It also has signal lights for heater power and the circulating pump.
- **Circulating Pump Jumper** – This jumper on the control board allows you to run the circulating pump and test system circulation without turning the heater on.
- **Battery Connector** – Connection points for positive and negative power from house battery to the heater.
- **Remote Connector** – Connection point for the cable from the remote LCD panel.
- **Service Switch** – The service switch allows full operation (service switch ON) or partial operation (service switch OFF) of the heater control board. In the OFF position, it will only allow the circulating pump and cabin fan to run in response to both a call for heat from the thermostat or domestic water aquastat, and the presence of an alternate heat source (engine or electric heating element) supplying short circuit fault reset function. This is performed by turning the service switch OFF, then ON.
- **Hour Meter** – Located on the front of the heater, the hour meter counts the accumulated operating hours for the heater.
- **Remote LCD Panel** – This panel enables the diesel burner and allows operational control and fault reset from inside the vehicle. The panel also provides diagnostic information and a fault history. The panel connects to the control board via a supplied 25' RJ11 cable. A 50' cable is available as an option.



6.6 What NOT to Do

Never shut off the heater power via an inline battery or master switch while the system is running. Never disconnect the battery when the heater is running, and never disconnect the battery while the inverter is charging.

NOTICE

Doing either will severely damage the heater because it fails to automatically purge the combustion chamber. Such damage is detectable upon inspection and will *not* be covered under warranty. Always shut the system off using the normal system controls, after it has completed its purge.

When running in bypass mode, never leave the heater unattended.



6.7 Installation Procedure

Consult the following table for required wire gauges and lengths. Consult *Figure 6-3* to view how various components are connected.

CONDUCTOR SIZES (GAUGE) FOR 3% DROP IN VOLTAGE

Length of Conductor from Source of Current To Device and Back To Source – Feet

		<u>10</u>	<u>15</u>	<u>20</u>	<u>25</u>	<u>30</u>	<u>40</u>	<u>50</u>	<u>60</u>	<u>70</u>	<u>80</u>	<u>90</u>	<u>100</u>
	<u>AMPS</u>												
5	-	18	16	14	12	12	10	10	10	8	8	8	6
10	-	14	12	10	10	10	8	6	6	6	6	4	4
15	-	12	10	10	8	8	6	6	6	4	4	2	2
20	-	10	10	8	6	6	6	4	4	2	2	2	2

© American Boat and Yacht Council, Inc.

Section 6, Wiring the Electrical System

- 1** Mount the control box adjacent to and accessible to the heater unit. Mount it vertically, not horizontally. Do not mount it close to excessive heat.
- 2** Wire the positive terminal of the house battery through a 25 amp, heavy-duty rated fuse (using #10 gauge wire) to the positive terminal on the control board inside the main control box. Wire the negative terminal of the house battery to the negative terminal of the control board. Wire the heater ground wire directly to battery negative.
- 3** Using the recommended wire gauges, prepare all wire terminations for approved connections from the control board to each of the fan heaters and thermostats (and any optional switches).
- 4** Wire the fan heaters to the terminals in the control board using #16 wire (minimum) and a #8 fork connection on each fan. See *Figure 6-3*. There are four terminals, F1 to F4, corresponding to the four heating zones.
- 5** Connect the fan grounds to the negative terminal of the battery or to an adjacent chassis ground location.
- 6** Wire the thermostats for the fan heaters to the terminals in the control board using #18 gauge wire (minimum) and a single #8 fork connection. See *Figure 6-3* for the correct terminals (T1 to T4, and T-C common).
- 7** If domestic water heating, engine waste heat, or summer/winter loop functions of the heater are required, see *Section 9 - Domestic Hot Water Heating* and *Section 10 - Engine Heat Management* for details.
- 8** Install the switch between the fan circuit and the positive DC fan connection using #16 wire (minimum) and a #8 fork connection. See *Figure 6-2* for a switch wiring diagram.
- 9** Mount the remote panel in an interior area where it can be easily accessed. Any accessory switches should be mounted adjacent to the remote panel for ease of use.
- 10** Connect the remote cable from the control board to the remote panel.
- 11** Ensure that all pre-wired connections between the heater and control box are secure.

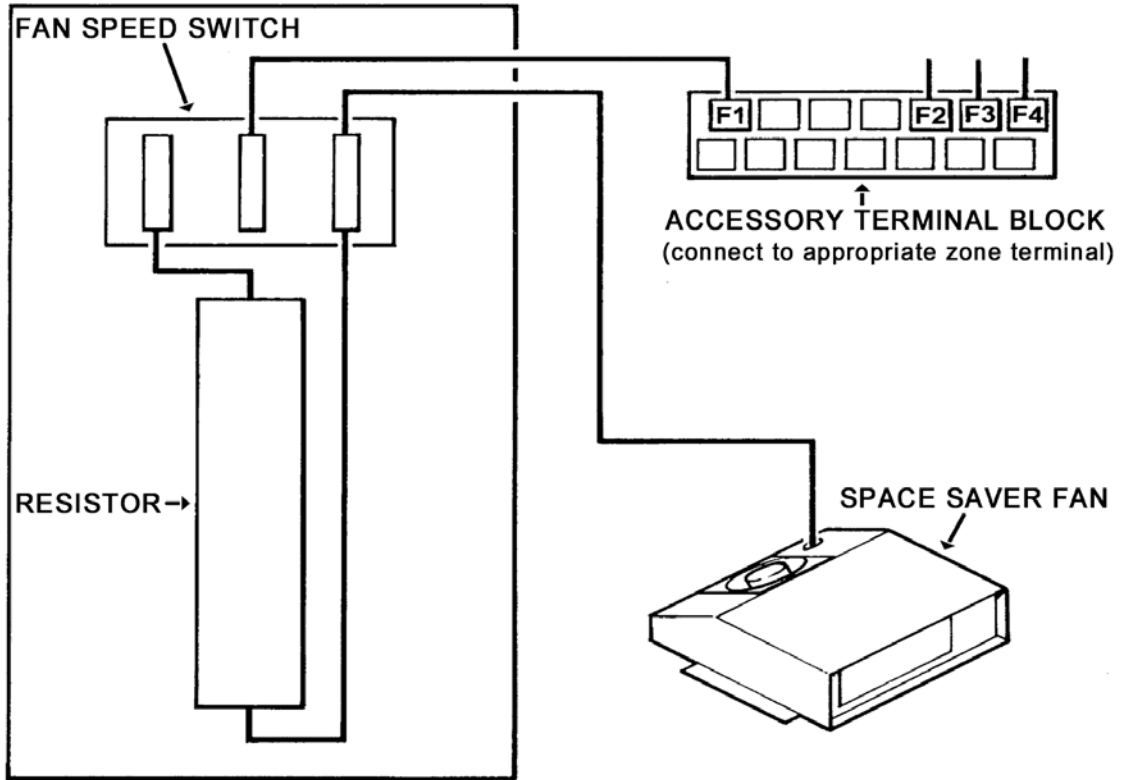

Figure 6-2: Wiring for a Fan Speed Switch

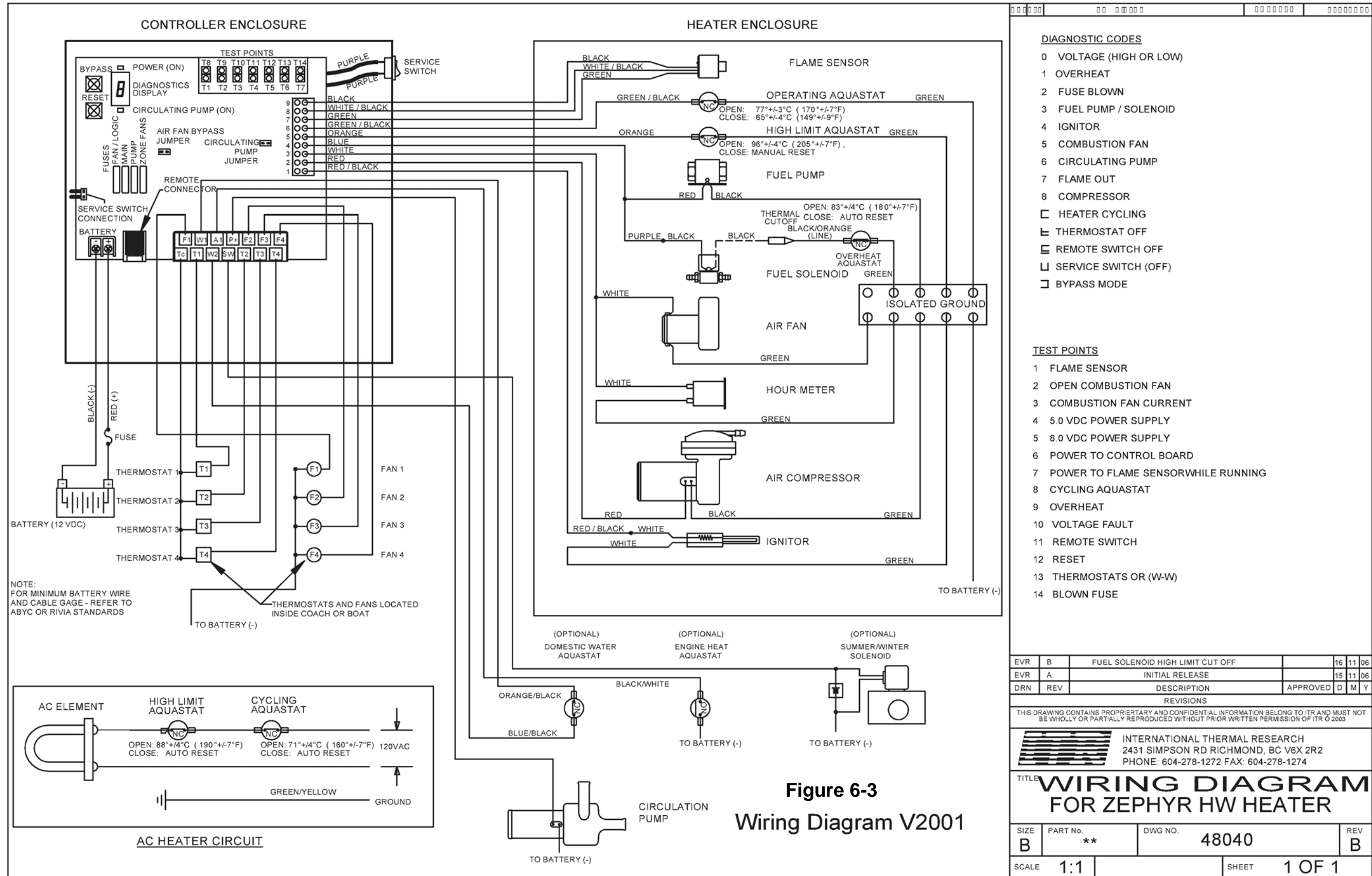
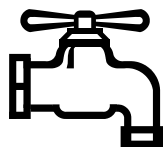

Figure 6-3
Wiring Diagram V2001

Plumbing the System



7.1 Before You Begin

For an efficient heating system, you must:

- Install a pump with enough capacity to provide sufficient coolant flow to all components in the system.
- Install the appropriate number of cabin fans for the space to be heated.
- Minimize heat loss from coolant tubes and hoses.
- Eliminate any air within the system .

Installing too many cabin fans may reduce the efficiency of the individual fans, resulting in less overall heat output. Without adequate flow to the cabin fans downstream, fans located directly after the heater can starve a system.



7.2 Plumbing Components

Expansion tank — allows the circulating fluid to expand when it gets hot and works in conjunction with the overflow tank. Mount either a horizontal or vertical expansion tank as the highest point of the system. Connect the outlet of the heater to the inlet of the expansion tank and the outlet of the expansion tank to the inlet of the circulation pump. **Never use a radiator cap with more than a maximum pressure relief of 7 lbs.**

Never remove the expansion tank cap when the system is hot and or running. Scalding coolant will be forcefully expelled, and could cause serious injury. Only remove the cap when the system is cold.

Circulating water pump — when used with the **Oasis® Zephyr™ HW**, the circulating water pump must be installed below the expansion tank. This will allow fluid from the expansion tank to gravity feed the pump. Jumper terminals are located inside the main control box that will power the pump independent of other heater functions when it is time to fill and purge the system.



TIP →

Reduce heat loss as much as possible by insulating the hose where it may be exposed to outside air. However, when you run hose through closets, cupboards, and storage lockers, a little heat loss is desirable to reduce moisture in these areas.

Overflow Tank — allows you to monitor fluid levels and add fluid to the system. An approved overflow bottle must be made of heavy-duty plastic and mounted firmly to a vertical surface. An overflow bottle (part# 10089) similar to that pictured at left is available from ITR. A heat-rated 3/8" ID hose connects to the outlet on the filler neck of the expansion tank and the inlet of the overflow bottle. A drain hose should be connected to the overflow bottle for external drainage. Unless the system is overfilled, drainage from this hose is unlikely, but as a precaution, the drain hose should be installed and directed toward the ground.

Heater Hose/Pex Tubing — Uses heavy-duty heater hose or 5/8" ID PEX tubing. Slip-on foam insulation coverings may be used over the hose, tubing and fittings to reduce heat loss. Secure all hose connections with constant-tension spring clamps. Various connection and clamping methods are shown in *Figure 7-1*. When using heater hose, be careful to avoid tight bends that will create a restriction. Plastic bend supports (part# 8048) are available that provide pex tube support for 90° bends. Pre-formed rubber elbows (part# 6071) are used for 90° connections to the heat exchanger fans.



Air Bleeder Vents — Air vents can be installed at strategic points within the plumbed system where air might accumulate. An inline bleed assembly (part# 2215) is available for this purpose.



Shut-off Valves — Inline shutoff ball valves should be installed on either side of an item to isolate it so it can be serviced or replaced without draining the system.



NOTICE

7.3 What NOT to Do

The heating system's circulating water pump is the most critical part of the heating system. **Never** let the pump run dry or you will damage the impeller. This is not covered under warranty.

Don't use low-quality heater hose.

Don't let the hose come into contact with solvents, which may cause it to soften and swell. If there is any risk that solvents may contact the hose, insert the hose into PVC plastic tubing for protection.



7.4 Installation Procedure

To install and connect the plumbing components and heater hose see *Figure 1-2* and *Figure 7-2* for typical plumbing layout diagrams.

- 1** Mount the overflow tank adjacent to the expansion tank at about the same level, in a location that allows fluid to be added to it easily.
- 2** Connect the overflow tank to the expansion tank inlet fitting using a clear plastic 3/8" hose. Secure both connections with a clamp.
- 3** While referring to *Figure 7-2*, connect the outlet of the heater to the inlet (top) of the expansion tank. Connect the outlet of the expansion tank to the inlet of the circulation pump. Use constant-tension spring clamps on all hose connections. A reducer and a short piece of 1/2" hose is needed to connect the 3/4" hose to the 1/2" connections on the circulation pump.
- 4** Lay out the heater hose horizontally through the vehicle, and connect the fan(s) in a series loop. Keep high points to a minimum.

- 5 Ensure there are no kinks or sharp bends that might restrict the coolant flow. For PEX tubing bends, fit the tubing into a plastic bend support (available for 5/8" and 3/4" tubing). Standard heater hose does not require bend supports but do not bend the hose to the point of collapsing.
- 6 Connect the outlet of the single fan or the last fan in the loop to the inlet of the **Zephyr**.
- 7 To make use of the engine heat management feature (see *Section 10 - Engine Heat Management*) connect the hoses that run to and from the engine to the appropriate connections on the back of the heater (see *Figure 10-1*). Consult the vehicle manufacturer's information for tying into the engine cooling system. The connections on the back of the heater are 1/2" NPT.

NOTICE

Using a silicone spray lubricant will make hose connections much easier. **DO NOT USE PETROLEUM BASED LUBRICANTS ON HOSE CONNECTIONS.** Pex to hose connections (see *Figure 7.1*) require a pex insert (part#61008)

- 8 Make sure all connections are secure and clamped.

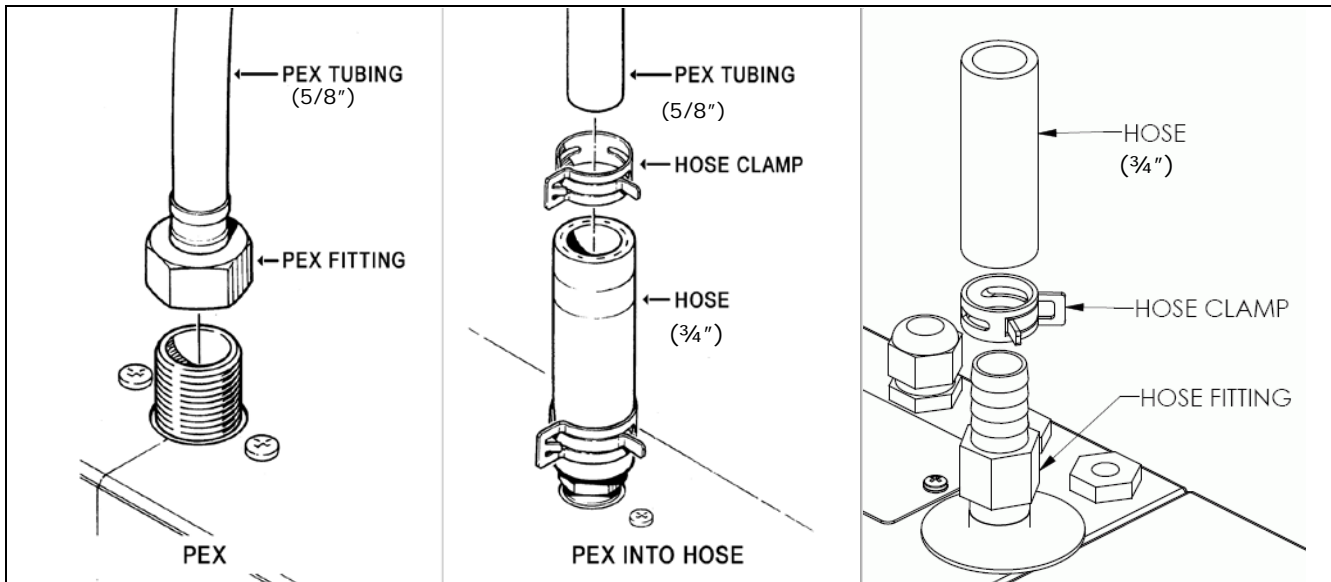

Figure 7-1: Three approved methods of installing heater hose (consult ITR for alternative methods and required parts)

Section 7, Plumbing the System

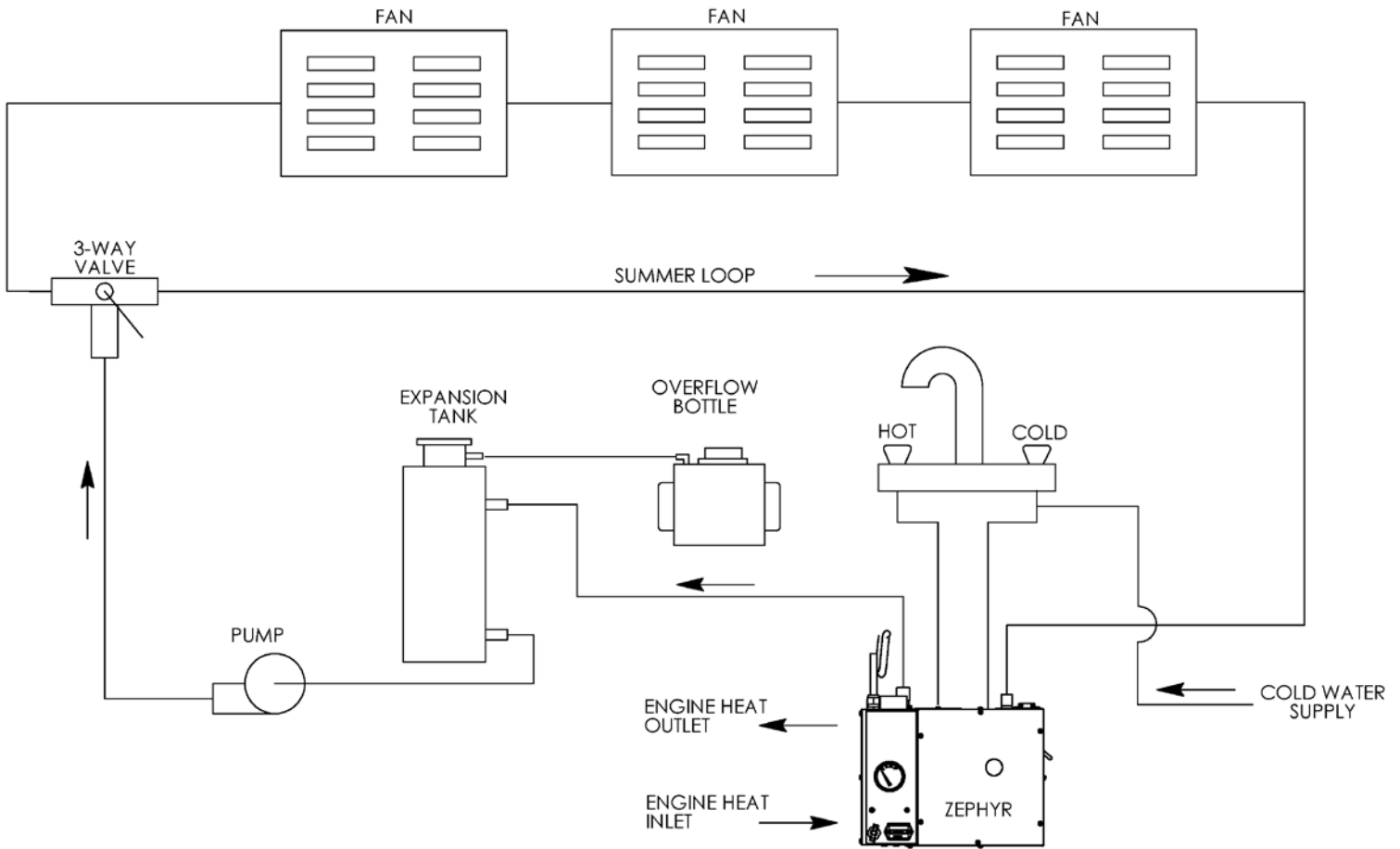

Figure 7-2: Single loop system with three fans and optional summer loop.

Filling and Testing the Circulation System

**TIP →**

If you fill the system with a 50/50 mix of antifreeze and water, this may save you from having to drain and refill the system.

However, if you are unsure of the installation, it's better to fill and test the system with water first.

8.1 Before You Begin

After the heating system has been installed, you are ready to fill the system with fluid for purging and testing purposes.

There are two recommended ways you can fill the heating system with fluid and purge it of air at the same time:

- Through the expansion tank
- Through a priming manifold

These methods are described below. They are very similar, but the manifold method provides a permanent, built-in mechanism for filling and purging. When using the manifold, you will need a **separate self-priming pressure pump (30 – 40 PSI)**.

After the first 50 hours of operation, vehicle movement may cause air bubbles to be dislodged. Monitor fluid levels carefully and add fluid if necessary.



8.2 What NOT To Do

Don't forget to remove the circulating pump jumper (see *Figure 6-3*) and store it on a single jumper pin after filling and purging. Otherwise, the pump will run continuously.

Do not attempt to purge the system without installing an expansion tank in the system. Do not bypass the expansion tank when purging the system. Failure to install the expansion tank or bypassing the expansion tank prior to purging the system will result in permanent damage to the heater.

NOTICE

Always use a non-toxic Propylene-glycol based antifreeze with additives generally recognized as safe (GRAS) by the FDA.

NOTICE

Never let the circulation pump run dry during filling and purging. Never operate the pump without fluid in the system.

Continue purging until you can no longer hear bubbling within the system or see cavitation within the pump. This ensures that any trapped air is removed from the system. Leaving air in the system may cause incorrect heater operation and may cause damage to the unit from overheating. Such damage is not covered under warranty. After 10 hours of system operation, check the fluid levels and add fluid if necessary.

! DANGER

Never remove the cap on the expansion tank when the system is hot and running. Scalding hot water may be forcefully expelled.

8.3 Procedure for Expansion Tank Filling Method

What follows is the easiest and quickest method by which to fill the system. This method, however, will only be effective if the circulation pump is located directly below the expansion tank.

- 1 Remove the lid from the expansion tank and, using a funnel, fill the tank to a level that is above the tank return connection but below the filler neck.
- 2 Turn on the heater's circulating pump using the pump jumper (See *Figure 6-3*) and allow the pump to draw fluid from the expansion tank.
- 3 Continue to fill the expansion tank as fluid levels drop. Once the fluid can be seen flowing into the expansion tank from the return connection, the system is full.
- 4 Run the circulation pump for at least 10 minutes to assure that any trapped air is forced out.

- 5 Top up the fluid level to just below the filler neck of the expansion tank and replace the expansion tank cap.
- 6 Remove the pump jumper and return it to one of the pins for storage.

NOTICE

Do not let the circulation pump run dry while filling the system using the expansion tank method.



8.4 Procedure for Manifold Filling Method

This method involves permanently installing a priming manifold in-line with the circulation loop. A priming manifold is available from ITR. Note that this method requires a self priming pressure pump (30 – 40 PSI) that has a built in pressure switch.

Use this method if you have installed PEX tubing for the heating system.

To fill, purge, and test the heater's circulation system using the manifold method, see *Figure 8-1* and adhere to the following procedure:

- 1 Put the pressure pump suction hose into a 5-gallon tank of 50/50 mix of antifreeze and water. Equip the hose with a screen mesh to capture any debris in the mix.
- 2 Attach the outlet of the self-priming pump to the manifold inlet and a spare hose from the tank to the manifold outlet. (See *Figure 8-1*)
- 3 Close the middle valve (2) and open both in-outlet valves (1 & 3). This forces the fluid to circulate through the 50/50 tank
- 4 Check to ensure all air vents and drains are sealed.
- 5 Start the pressure pump.

Section 8, Filling and Testing the Circulation System

- 6** As fluid is pumped out of the 50/50 tank, make sure that the supply pump never draws air.
- 7** Slowly add more fluid to the tank until all air has been expelled and the mixture starts coming out of the return hose in the 50/50 tank. Keep the fluid level in the tank above the inlet of the suction hose. This will flush the system of any debris and purge the lines of air.
- 8** Monitor the heating system during filling and purging to ensure:
 - all fittings remain secure.
 - there are no leaks in any connections or hosing.
 - there is good flow through the expansion tank.
 - pressure in excess of 7 PSI does not build up.
- 9** If you discover any leaks, temporarily stop the filling procedure to repair the leak.
- 10** Continue running the pressure pump for about 10 minutes *after* it has purged all air from the system. Continue monitoring for leaks.
- 11** Stop the pressure pump and close valves 1 and 3 right away to prevent the system from draining. Open valve 2 to allow normal system operation.
- 12** If you filled the system with straight water, drain it and refill with a 50/50 mix of antifreeze and water.
- 13** Fill the overflow tank to the correct fluid level.
- 14** Turn on the heater's circulating pump by connecting the pump jumper on the control board (see *Figure 6-3*).
- 15** Check that the circulating pump runs quietly and smoothly. If there is still bubbling or if cavitation is present, purge the system again.
- 16** Double check the entire plumbing system for leaks. Open and close all air vents to eliminate remaining air bubbles.
- 17** Recheck fluid level and ensure there is circulation in the expansion tank.
- 18** Remove the pump jumper on the control board. This returns the pump to normal operation.

Section 8, Filling and Testing the Circulation System

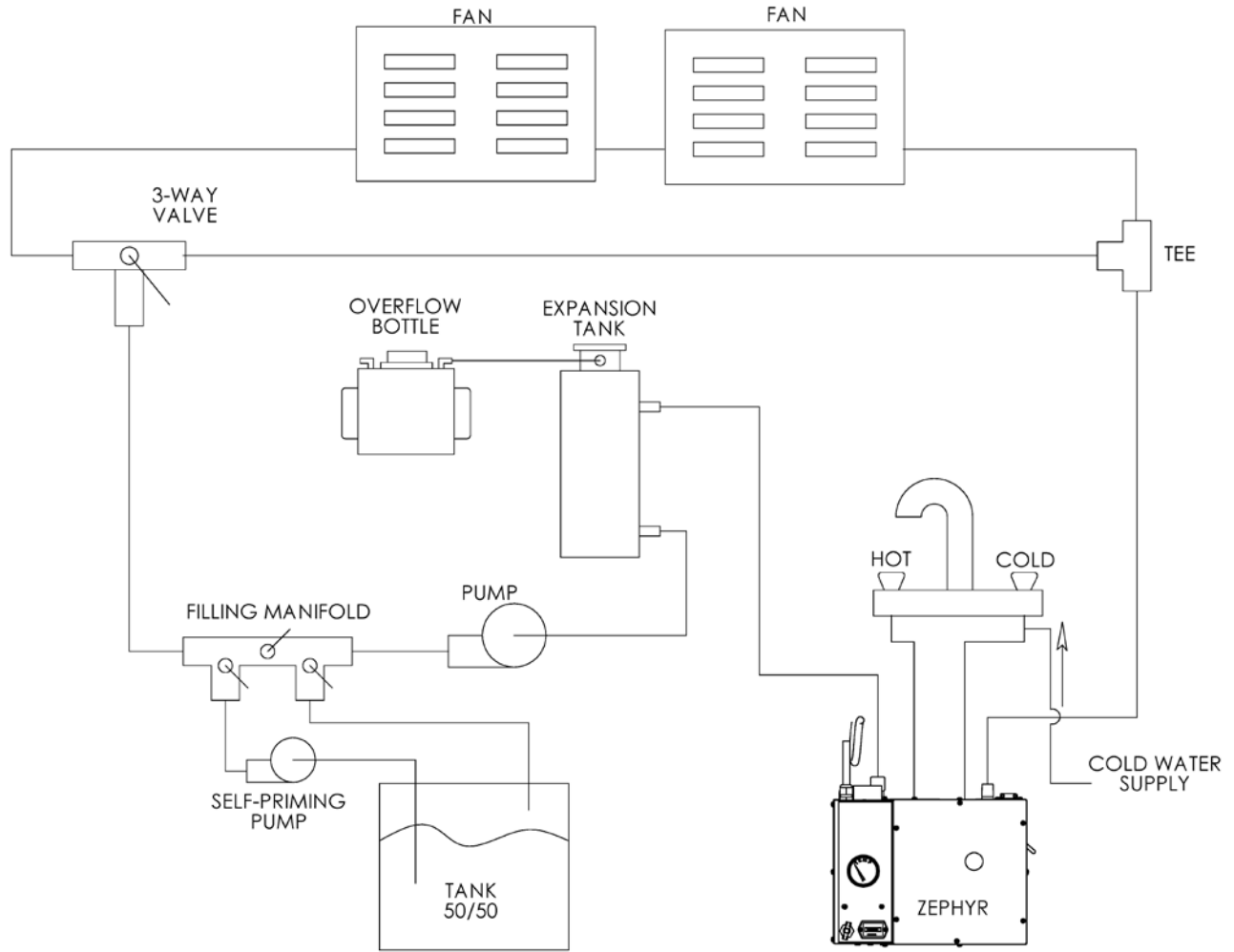

Figure 8-1: Filling system using “manifold method” system loop shown with optional summer loop valve.

Domestic Hot Water Heating



9.1 Before You Begin

During the summer months, when you need hot domestic water but don't need space heating, use the optional three way valve or electric solenoid to route coolant through the heat exchanger only, and not through the space heating loop. (See *Figure 9-1*). This valve should be mounted so it is easy to reach. (See *Figure 6-3* for details on hooking up an electric solenoid).

The heat exchanger in the **Zephyr** has an additional heat transfer loop. If this loop is plumbed to the engine, when the engine is running, heat generated by the engine will be transferred to the heating system, providing space heat and hot water without running the burner. An optional pump can be installed to pre-heat the engine using the **Zephyr**. *Section 10- Engine Heat Management* provides details of the engine heat management feature and *Section 7.4 - Plumbing Installation Procedure* provides instruction for connecting the **Zephyr** to a vehicle's engine. Consult the vehicle manufacturer's information to tie into the vehicle's engine coolant system.

For help with wiring the electrical components of the heat exchangers, see the wiring schematic, *Figure 6-3*.

9.2 Domestic Hot Water System

The Oasis® Zephyr™ HW will provide continuous hot water when the burner is firing. When the temperature gauge indicates the coolant inside the tank is hot and the heater has cycled-off, short draws of water will be available without activating the burner or electric element.

The components of the **Oasis® Zephyr™ HW** that provide domestic hot water to the system include:

Heat Exchanger — The stainless steel flat plate heat exchanger is UL and CSA approved for domestic water heating. It is an internal component of the **Oasis® Zephyr™ HW** and is intended for hot water output.

Aquastat — An aquastat (temperature sensor inside the heater) signals the burner to fire when there is a call for hot water.

Mixing Valve — The mixing valve provides temperature control and prevents scalding.

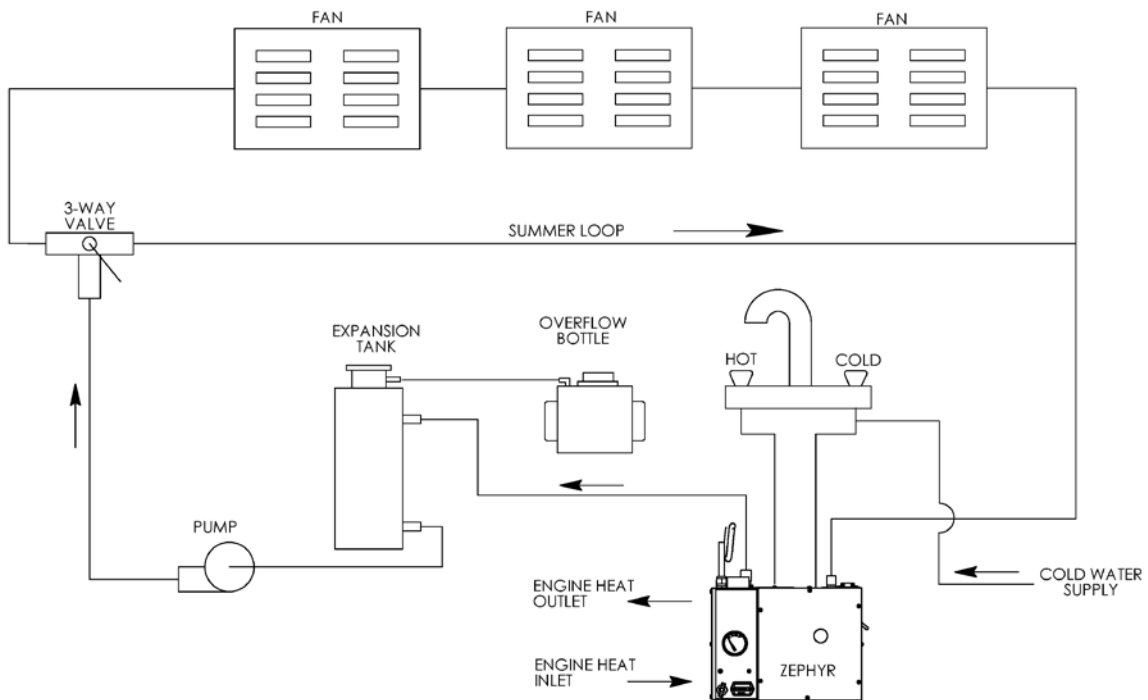

Figure 9-1: Single loop system with three fans and optional summer loop.

Engine Heat Management

10.1 Engine Waste Heat Function



Besides providing space and domestic water heating, your **Oasis® Zephyr™ HW** heater can be used to preheat a vehicle's engine and to recycle waste heat produced by the engine.

A liquid cooled engine produces a large amount of waste heat while running. If a thermostat or aquastat is calling for heat, the **Oasis® Zephyr™ HW** can use this waste to heat a vehicle and provide domestic hot water. The **Zephyr's** heat exchanger will also preheat an engine by transferring heat to it from the **Oasis® Zephyr™ HW** heater. An optional, manually switched pre-heat pump must be installed to enable this feature.

NOTE: The engine heat function can be used with the service switch ON or OFF.

CAUTION

Where there is a chance of contaminating domestic water when using a hydronic heating system, use a non-toxic, propylene-glycol based antifreeze with inhibitors generally recognized as safe (GRAS) by the FDA. Do not use automotive, ethylene glycol, or any undiluted or petroleum based antifreeze, as these are toxic.

CAUTION

Do not connect your engine cooling system directly to the heating system. Before connecting anything to your engine, consult your engine owner's manual for any restrictions on plumbing into the engine cooling system.



10.2 Waste Heat Function Installation Procedure

- 1 To make use of engine heat without running the burner, turn OFF the heater control switch located on the remote indicator panel. This will stop the burner from operating, but all other heater functions will operate normally. (Note: the burner switch can remain on while heating the system with heat from the vehicle's engine. The burner may fire initially if the system is cold, but will shut-off once the cycle temperature is reached and remain off as long as the engine is providing heat to the system). Start the engine.
- 2 When the engine temperature aquastat, located on the heat-exchanger, warms to its pre-set temperature, it will switch on the circulating pump of the heating system and distribute heat, assuming any thermostats or domestic water aquastat are calling for heat.
- 3 The circulating pump will continue to operate until the engine aquastat has cooled down, or until all thermostats or domestic water aquastats are satisfied.

10.3 Engine Pre-Heat Function

As an option, the **Oasis® Zephyr™** can also be used to pre-heat a vehicle's engine before starting. The **Oasis® Zephyr™ HW** has two plumbing connections on the back panel that connect to the engine coolant system. Pre-heating the engine makes it easier to start in cold temperatures.

The optional engine pre-heat function requires a manual switch mounted inside the vehicle's interior (not supplied) which activates a separate pump (not included) to circulate engine coolant. In order for the **Oasis® Zephyr™ HW** to provide heat to a cold engine, the burner and/or the electric heating element must be on, and a thermostat must be turned up to initiate a call for heat. If using the electric heating element, the vehicle must be connected to a source of power (120VAC). See *Section 6.4 - Wiring the Electric System, 120/240 VAC Options and Installation Procedure* for using the electric heating element.



10.4 Engine Pre-heat Installation Procedure

- 1** Mount a manual switch in an appropriate place in the vehicle's interior, usually near the dashboard.
- 2** Wire the manual switch to the installed engine pre-heat water pump. Connect it to the main feed on the control board that connects to the vehicle's power source beside the battery connection. (See *Figure 6-3*) The switch circuit should include a 5 amp fuse on the power side.
- 3** Connect the ground-wire of the engine pre-heat pump to vehicle battery's negative terminal.
- 4** To test the engine pre-heat function: if the **Zephyr** is not on and at operating temperature, turn ON the burner and/or electric heating element and turn up a thermostat to initiate a call for heat. The **Oasis® Zephyr™** will start distributing heat to the engine. Start the vehicle. The engine temperature gauge should indicate that the engine is warm.
- 5** Note that the burner outputs 33,000 BTUs, while the electric heating element outputs 5,100 BTUs. It will take much longer to pre-heat the engine with the electric heating element only.

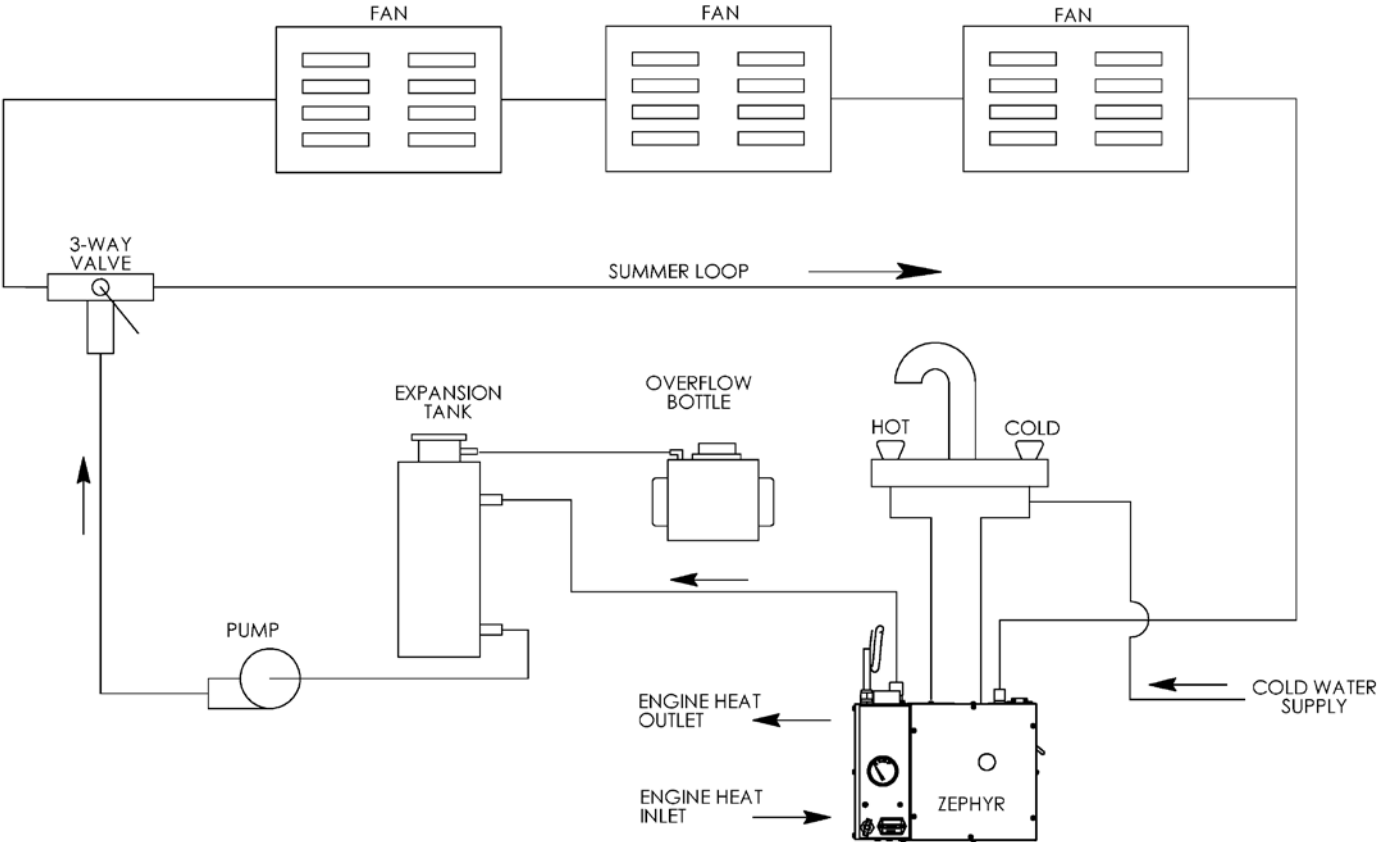

Figure 10-1: Single loop system with three fans, optional summer loop and engine coolant flow direction.

Operation



The initial start-up of your **Oasis® Zephyr™ HW** heater must be done by an authorized service person. Be sure that all components have been properly installed according to the instructions laid out in this manual prior to the initial start.

11.1 Starting the Heater

Never attempt to start the heater without the burner faceplate securely fastened to the burner box

The major steps in starting the heater are as follows:

1. Turn on the ON/Off control switch, located on the remote interior panel.
2. Turn up the zone thermostat to a setting higher than room temperature.
3. Start the heater by switching the service switch to ON. This switch is located on the side of the electronic control box.

11.2 Signs of Normal Operation

When the heater is operating normally:

- The igniter will glow and the combustion air intake fan and the circulating pump will begin to run. Whenever the pump is running, a green LED at the bottom of the LED display will be on.
- A few seconds later, the fuel pump will start delivering fuel to the regulator, the compressor turns ON, and fuel is drawn to the burner nozzle. The fuel is atomized and sprayed into the combustion chamber to start combustion.

- After the ignition period (about 10 seconds), the igniter shuts OFF, and the burner continues to operate. The heater will operate until all the zone thermostats are satisfied, or until the heater reaches its normal water operating temperature of approximately 180°F, as shown on the front of the Zephyr. Once the normal operating temperature is reached, the burner itself will cycle off and the combustion fan will operate for an additional two minutes to purge the burner.
- If a zone thermostat or domestic water heater aquastat is not satisfied, the circulating pump will continue to operate. If a thermostat cannot be satisfied by the residual heat in the system and the water temperature drops, the burner will restart and cycle until all thermostats are satisfied. Once all thermostats are satisfied, the heater will purge for 2 minutes, and the circulating pump will stop. Alternatively, the circulating pump and cabin fans can run using the A1 terminal on the control board (see *Figure 6-3*). An aquastat temperature sensor, wired to the A1 terminal on the control board, will control the engine heat function. The circulating pump will run once the engine heat is available (A1 connected to vehicle battery's negative terminal) and any thermostat or domestic water aquastat is calling for heat. Note: The engine heat function can be used with the service switch ON or OFF. After the heater has been running for a little while, the water outlet of the heater case should become warm. If the water hose leaving the outlet of the heater does not warm up immediately after the circulating pump comes on, water is not circulating properly and air may be in the system. Turn the heater OFF and check water circulation.

11.3 Main Control Board Operation

Once the heater is operating normally, you must check the operating safety functions of the main board. To make sure the safety functions work properly, squeeze off the flow of air from the compressor. This can be done with your fingers, or by using a pair of smooth faced pliers. The hose may need to be pinched for several seconds before the heater stops. Pinching off the hose will shut off the flame. If you continue to block the air inlet, the heater will try to restart two more times. If it is unable to restart after two attempts, the heater will shut down, stopping the compressor and fuel pump. The control board will display a code '7.' Release the air hose, reset the control board, and the heater will continue with normal operation. This test assures the control board is functioning correctly.

11.4 Turning Off the Heater (for Seasonal Purposes)

NOTICE

NEVER shut off the power to the heater using the circuit breaker or a master switch, or disconnect the battery while the heater is running. Doing so will cause serious damage to the heater, which will not be covered under warranty.

To turn the heater OFF, turn OFF the control switch, located on the remote interior panel, and turn OFF the service switch on the main control board box. The room thermostat or the remote interior panel switch can be switched ON or OFF at any time, without harming the heater.

The heater will automatically run through the purge cycle, which takes about two minutes.

11.5 Using the Electric Heating Element

The electric heating element can be activated using the separate installed switch. If the switch has an indicator light, this light will come on. The electric heating element is operated independently of the control board. Sensors on the heater are monitoring tank temperature and controlling activation of the heating element. When the tank reaches a certain temperature, the heating element will automatically shut off. The heating element draws 12.5 Amps from the 120 VAC circuit.

11.6 Turning Off the Heater (for Maintenance)

To shut down the heater totally, for maintenance purposes **make sure to follow the steps below in the order listed:**

1. Turn OFF, the service switch on the electronic control box.
2. Wait until the heater has completed the purge cycle and turned itself OFF.
3. Disconnect the power supply.

11.7 Resetting After a Fault

When a fault occurs and has been corrected, you can reset the heater by switching the service switch on the side of the main control box OFF and back ON, or by doing the same with the remote interior panel control switch. This will reset the heater and clear the diagnostic code display.

Note: Component faults can only be reset using the service switch.

Troubleshooting

12.1 Overview

The electronic control board consists of a flash microcontroller programmed to monitor the timing and safety functions of the heater. Each time the board is energized by a call for heat, it will check its own circuits for any problems. Should a problem exist, the board will shut down.



You can easily monitor your **Oasis® Zephyr™ HW** heater's operation by checking the electronic control box. Faults or problems will be immediately picked up by the control board, and an LED diagnostic code indicator will light up to pinpoint the fault. Once the fault has been corrected, it can be reset by switching the service or remote switch OFF, then ON again. The diagnostic codes are described below.

12.2 Power On (Green)

The POWER ON indicator is lit whenever the service switch on the control box is ON and if the remote panel is switched ON, a small red LED on the lower right of the remote panel view box will also glow. If this light does not come on, check to see if the service switch is ON.

If the power ON light does NOT activate, check for a blown fuse.

12.3 Burner On

No diagnostic code will be displayed on the main board or the remote panel when the burner is ON and operating normally. A small red LED on the lower right of the remote panel view box will glow, indicating it is ON.

12.4 U – Service Switch Off

- The service switch is switched OFF.
- The burner will shut down if it has been running.
- The diagnostic code U will be displayed.
- The control board will purge the system, with the combustion fan and circulating pump running for two minutes. At the end of the purge period, the system will power down and will go into a low power consumption mode (10mA maximum). There will not be any display or LED indicators lit.

12.5 E Remote Switch Off

The remote panel is switched OFF.

- The burner will shut down.
- The diagnostic E code will be displayed.
- The control board will activate the combustion fan and circulating pump for two minutes in order to purge the system

If the remote switch is put in the ON position, the control board will resume operation and a small red LED will glow near the lower right hand corner of the remote panel view box. If there is no diagnostic code displayed or small LED glowing:

- Make sure the service switch is ON.
- Make sure the remote switch cable is plugged into the control box and remote switch.
- Make sure the remote rocker switch is working.
- Check for cable continuity.

12.6 C Heater Cycling (Normal Operation)

The operating (cycling) aquastat installed on the coolant tank of the heater has been satisfied.

- The burner will shut down.
- The diagnostic code C will be displayed.

- The control board will purge the burner using the combustion fan for two minutes and then stop. The circulating pump will run until the last thermostat is satisfied, then purge for two minutes and stop.
- To maintain system temperature, the operating aquastat will cycle the burner off at 170° F (77°C) and on again at 149°F (65°C).
- If the heater cools and fails to resume operations and the diagnostic code **C** continues to be displayed, the aquastat is faulty or has an open connection.

12.7 **E** - Thermostats off (Normal Operation)

All thermostats and aquastats are satisfied.

- The burner will shut down.
- The diagnostic code **E** will be displayed.
- The control board will purge the system using the combustion fan and circulating pump for two minutes. When any thermostat or aquastat calls for heat, the heater will resume normal operation.
- If the heater fails to resume operations, check thermostats and their connections.

12.8 **O** - Voltage Low or High

The power supply voltage is below 11Vdc or above 15Vdc

- The burner will shut down.
- The diagnostic code, **O** will be displayed.
- A buzzer will sound for 10 seconds.
- The control board will purge the system using the combustion fan and circulating pump for two minutes while checking if a voltage fault is still present.
- If the voltage fault has cleared, the control board will reset the alarm and restart the burner. If the condition has not cleared by the end of the purge period, the diagnostic code **O** will remain displayed. The control board will continue to check the voltage every half hour until the voltage fault has cleared, and then restart the burner. To manually reset the fault, switch the service switch or the remote panel switch OFF then ON again.

12.9 1 - Overheat

The high temperature limit has been reached.

- The burner will shut down.
- The diagnostic code, 1 will be displayed.
- The buzzer will sound for 10 seconds.
- The control board will purge the system with the combustion fan and circulating pump for two minutes while it is checking if the overheat condition still exists. If the condition exists, the diagnostic code 1 will continue to be displayed.
- In order to restart the burner, first check the circulating pump, the level of the coolant, and the movement of the coolant while the circulating pump is running. Reset the high limit aquastat (inside heater) and the fault indicator (turn the service or remote switch OFF then ON again). If the fault indicator does not reset, check for a faulty aquastat and proper grounding.

If a diagnostic code 1 lights up and the heater is not in an overheat condition, check the ground from the heater ground wire to the battery. The ground wire should be a minimum 10 gauge and connected directly to the battery.

12.10 2 - Fuse Blown

One of the fuses on the control board has blown.

- The burner will shut down.
- The diagnostic code 2 will be displayed.
- The buzzer will sound for 10 seconds.
- The control board will purge the system using the combustion fan and circulating pump for two minutes while it is checking for a blown fuse.
- If a blown fuse exists, the diagnostic code 2 will continue to be displayed.
- In order to restart the burner, replace any blown fuses. Then reset the fault indicator by switching the service switch or the remote panel switch OFF then ON again.

12.11 3 - Fuel Pump/Solenoid

The fuel pump or fuel solenoid has shorted.

- The burner will shut down.
- The diagnostic code 3 will be displayed.
- The buzzer will sound for 10 seconds.
- The control board will purge the system using the combustion fan and circulating pump for two minutes.
- In order to restart the burner, check the fuel pump and solenoid for a short circuit, then reset the fault indicator by switching the service switch OFF then ON again.

The remote panel switch does not reset short circuit faults.

12.12 4 - Igniter

The igniter is open or shorted

- The burner will shut down.
- The diagnostic code 4 will be displayed.
- The buzzer will sound for 10 seconds.
- The control board will purge the system using the combustion fan and circulating pump for two minutes.
- In order to restart the burner, check the igniter and its connections. Then reset the fault indicator by switching the service switch or the remote panel switch OFF then ON again. Note that diagnostic code 4 will be displayed if the igniter is open or shorted.
- The remote panel switch does not reset a short circuit fault.

12.13 5 - Combustion Fan

- The combustion fan is open or shorted.
- The burner will shut down.
- The diagnostic code 5 will be displayed.
- The buzzer will sound for 10 seconds.
- The control board will purge the system using the circulating pump for two minutes.
- In order to restart the burner, check the combustion fan. Then reset the fault by switching the service switch or the remote panel switch OFF then ON again. Note that diagnostic code 5 will be displayed if the combustion fan is open or shorted.
- The remote panel switch does not reset a short circuit fault.

12.14 6 - Water Pump

The water pump is shorted.

- The burner will shut down.
- The diagnostic code 6 will be displayed.
- The buzzer will sound for 10 seconds.
- The control board will purge using the combustion fan for two minutes.
- In order to restart the burner, check the water pump. Then reset the fault indicator by switching the service switch OFF then ON again.
- The remote panel switch does not reset a short circuit fault.

12.15 7 - Flame Out

The flame went out or did not ignite.

- The burner will shut down.
- The diagnostic code 7 will be displayed.
- The control board will try to restart the burner two more times. After two unsuccessful restart attempts, the buzzer will sound for 10 seconds.
- The control board will purge using the combustion fan and circulating pump for two minutes. The diagnostic code 7 will continue to be displayed.

The single most common cause of flame faults is air entering the fuel system. This is normally caused by low fuel levels or loose fittings. As air accumulates and passes through the nozzle, it interrupts the fuel supply and shuts down the burner. When this happens, it may be necessary to reset the heater a few times to ensure all air has passed through the system. The **Zephyr** is equipped with a fuel manifold that helps to eliminate air in the supply line by allowing air to pass into the return line. Air may still, however, enter the nozzle and interrupt the fuel supply to the burner. If air continues to disrupt the flow of fuel into the nozzle, it is likely there is a leak somewhere in the fuel system.

A flame-out may also be caused by a dirty nozzle or a dirty filter. When diagnosing a flame-out, check the condition of the nozzle and clean it or replace it if necessary. Also check the condition of the nozzle o-ring and nozzle filter. (See *Section 13.3 - Nozzle*)

If the external fuel filter is dirty, it could create restriction in the fuel line and cause flame faults. Inspect and replace as necessary.

A flame fault can also be caused by starvation of fuel if the heater's fuel supply is shared with other equipment.

- Check connections on the fuel tank, fuel pump, and regulator. Check fuel lines for holes or cracks. Make sure the nozzle or fuel filters are not clogged or excessively dirty.
- Check the airline hoses for any restriction of airflow through the compressor. Restrictions may be caused by a crimped hose, clogged air filter, or a loose or leaking air hose connecting the compressor outlet to the nozzle. Check the air filter inlet for any obstructions.
- Check for negative pressure in the area around the heater. When the engine is running, it can draw air back through the heater's exhaust pipe. All intake air and exhaust connections must be tight.
- Check for restrictions or leaks in the combustion air in-take hose or exhaust pipe.
- Check for open circuit on fuel pump/solenoid and compressor.

To restart the burner, check the fuel supply and clean the nozzle. Then reset the fault indicator by switching the service switch or the remote switch OFF then ON again.

- If the conditions that caused the flame fault have been addressed and the heater does not ignite, the thermal cutoff may have been activated by an overheat condition within the burner box. Using a multimeter, check for continuity across the leads of the thermal cutoff. The thermal cutoff is located inside the burner box, and is mounted on the left side of the box. If there is no continuity, the heater **MUST** be inspected, and the reason for the overheat condition must be determined and corrected before further use. A replacement thermal cutoff must be obtained from your dealer.

12.16 **B** - Compressor

The air compressor has shorted.

- The burner will shut down.
- The diagnostic code, **B** will be displayed.
- The buzzer will sound for 10 seconds.
- The control board will purge the system using the combustion fan and circulating pump for two minutes.
- In order to restart the burner, check the air compressor. Then reset the fault by switching the service switch OFF then ON again.

The remote panel switch does not reset a short circuit fault.

12.17 **J** - Bypass Mode

The bypass mode is a service feature to be used by authorized service personnel only. The bypass mode overrides the operating aquastat, remote switch, voltage fault, fuse blown fault, flame out fault, open igniter fault, open fan fault, and thermostats. All these safety devices will be bypassed for five minutes.

- While in bypass mode, the diagnostic code **J** will be displayed and the Power ON LED will flash rapidly.
- If the heater's cycling aquastat is satisfied, or the overheat limit is reached, the burner will stop and purge for two minutes while displaying one of two diagnostic codes; heater cycling **C**, or **I** for overheat. The Power ON LED will flash slowly. The heater must then cool down before continuing in bypass mode. The bypass mode will timeout in five minutes. After the first three minutes running in bypass mode, the heater will automatically purge for the last two minutes.

12.18 Water Pump On (Green)

The green light located directly under the LED digit on the main board will come on whenever the circulating water pump is active.

12.19 LCD Readout Remote Panel (optional)

This panel will display the diagnostic explanation, which will match up to the diagnostic code on the main board. A small buzzer will sound for 10 seconds to alert you of a fault.



12.20 Flame Sensor Module

The Flame Sensor consists of: a sealed module with a photodiode aimed at the flame; a red LED indicator light and 3 wires (red (+), black (-), and yellow (signal)). All are connected to the main board). Under normal operating conditions, whenever the burner ignition begins, the red LED will flash once, indicating the red and black wires are connected and the module is receiving power and working properly. Once the burner is ignited, the LED will begin to flicker like the flame. If, for any reason, the flame is extinguished, the flickering will stop and the control board will shut down the heater.



If the yellow (signal) wire is disconnected, the board will shut down. If all wires are properly connected with module flashing and the board still shuts down, and diagnostic code 7 (Flame Out) appears, the board may be defective.

12.21 Test Points

The test points on the **Oasis® Zephyr™ HW** electrical control board allow for testing and troubleshooting of the electrical system. You will need a voltage meter to plug into the test points.

Test Point	Component	Results / Optimal Condition
TP1	Flame Sensor	A voltage meter should show a voltage of about 2 volts if the flame sensor detects a flame. If not, the voltage will be 0 volts. An oscilloscope will show a 0 to 5 volt square wave with a frequency of about 60 Hz if the flame sensor is detecting a flame.
TP2	Combustion Fan	Voltage will be between 4 and 5 volts if the combustion fan is operating correctly, and 1 volt if the combustion fan is not drawing any current (open).
TP3	Combustion Fan Current	Voltage will be between 1 and 5 volts if the combustion fan is drawing normal current, and 0 volts if the combustion fan is not drawing current.
TP4	5v Power Supply	Voltage should be between 4.8 and 5 volts. A lower voltage indicates a problem with the voltage supply to the control board.
TP5	8v Power Supply	Voltage should be between 7.9 and 8 volts. A lower voltage indicates a problem with the voltage supply to the control board.
TP6	Power To Control Board	The battery voltage supplied to the control board should be between 11 and 15 volts.
TP7	Power To Flame Sensor	The power to the flame sensor should read between 11 and 15 volts (same as battery voltage).
TP8	Cycling Aquastat	Voltage will be between 4.8 and 5 volts if the heater is cycling (cycling aquastat is open), and 0 if the cycling aquastat is closed.
TP9	Overheat Aquastat	Voltage will be 0 volts if an overheat condition is occurring or has occurred in the past two minutes (overheat aquastat is open). The voltage will be between 4.8 and 5 volts if the overheat aquastat is closed.
TP10	Voltage Fault	Voltage will be 0 volts if there is no voltage fault, and between 4.8 and 5 volts when there is a voltage fault.
TP11	Remote Switch	Voltage will be 0 volts when the remote switch is off, and between 4.8 and 5 volts when the switch is on.
TP12	Reset	Voltage will be 0 volts when the reset button is pressed, and between 4.8 and 5 volts when the reset button is not engaged.
TP13	Thermostats Or Domestic Water	Voltage will be 0 volts when the thermostat or domestic water system calls for heat and between 4.8 and 5 volts when heat is not called for.
TP14	Blown Fuse	Blown fuses for the burner, pump, or cabin fans will show a voltage of between 4.8 and 5 volts. Good fuses will show 0 volts.

12.22 Reduced Output

The heater may run without faulting, but at a reduced output. If this is noticed, it could be caused by the following:

- High altitude
- Dirty nozzle
- Defective regulator
- Too small a nozzle
- Poor water circulation
- Ash deposit in combustion chamber

12.23 Dirty Exhaust

The heater may run without faulting, but you may experience signs of soot, exhaust smoke and/or a pungent smell. This is usually caused by the wrong fuel to air ratio. Fuel to air ratio can be affected by the following:

- Low voltage
- High altitude
- Dirty compressor air filter
- Low compressor air output
- Restricted combustion airflow
- Low combustion fan output
- Partially clogged grooves in nozzle distributor

12.24 Carbon Monoxide Dangers

The American Boat and Yacht Council Inc. (ABYC) states:

Section 5.111: "Where heater is installed in an engine or bilge space, 100% fresh air shall be supplied for combustion."

Section 6.1: "Burners shall be of the mechanical draft type which employs a power driven fan, blower or other mechanism supplying air for combustion."

This means 100% fresh combustion air must be mechanically delivered through a sealed duct directly to the heater from outdoors. This is the recommended procedure no matter where the heater is installed. When combustion air is drawn from an unventilated heated space, the heater flame will become increasingly yellow as the oxygen in that space is consumed. An oxygen-starved flame produces excessive carbon monoxide (CO), some of which can easily escape the exhaust.

Carbon monoxide is a colorless, odorless, tasteless gas produced any time you burn a carbon-based fuel such as gasoline, wood, charcoal, kerosene, propane, or diesel. It disperses freely in the air and can accumulate in enclosed spaces or air pockets. RV owners and boaters are especially vulnerable to the dangers of CO because these vehicles have gas or diesel engines, as well as fuel-burning appliances, and their enclosed spaces can accumulate CO. CO is a cumulative poison; it can have fatal effects even at low concentrations.

A normal exhaust system is under constant attack from salt corrosion, gases, vibration, and impacts. It is important to inspect your exhaust system on a regular basis. Start with a visual inspection for signs of damage, and check each joint for discoloration from exhaust gas leaks or other signs that may indicate a possible leak. Inspect the entire system for corrosion, and check that clamps are in good condition and are secure.

Also, ensure that all ventilation systems are in good working order and not blocked. A poorly maintained heating system can produce excessive CO, so it's important to keep your **Oasis® Zephyr™ HW** clean, maintained on a regular basis, and in proper running condition. **Oasis®** hydronic heating systems should never produce smoke or a detectable odor. If this occurs, the heater requires service.

Maintenance



13.1 The First Few Weeks

About two weeks after your **Oasis® Zephyr HW** heater has been installed, you should conduct a general inspection of the entire system.

Check for any leaks in the exhaust system, fuel line system, coolant system and fresh water line system.

It is strongly recommended that the Oasis® Zephyr™ HW heater be started and allowed to run through one complete heating cycle at least every 30 to 45 days to ensure its proper function and to verify the proper operation of all components.

13.2 Adding Coolant

NOTICE

PRECAUTION: Where there is a chance of contaminating your domestic water when using a heating system, always use a non-toxic Propylene-glycol based antifreeze with additives generally recognized as safe (GRAS) by the FDA.

Do not use automotive, ethylene glycol, or any undiluted or petroleum based antifreeze as they can cause severe personal injury.



IT IS VERY IMPORTANT THAT YOU NEVER USE WATER ONLY AS A HEAT TRANSFER FLUID.

We recommend you use a mixture of 50% distilled water and 50% antifreeze as a heat transfer fluid. Cold weather conditions may dictate that more than 50% antifreeze is required in the coolant mixture. If this is the case, note that the added viscosity of the antifreeze solution may result in slower circulation throughout the system. Your antifreeze/water mixture should be changed every three years.

Antifreeze wears out and can become very acidic. USE DISTILLED WATER AS TOP-UP to replace system fluid lost to normal evaporation. Be cautious of the dilution levels of the antifreeze in the system and the possibility of freezing. Always winterize the freshwater system if left unheated in freezing temperatures.

A coolant conditioner can be added to keep the coolant alkaline. These inhibitors also prevent the coolant from forming calcium scales. If a conditioner is not installed in your system, check the pH level yearly. The components inside the heater should not normally require maintenance, except for periodic checks for obvious problems, such as leaks or overheating.

Note: Service kits are available from ITR for 1, 3 and 5 year service intervals. These kits contain the parts normally replaced during the respective service/maintenance intervals.

13.3 Nozzle

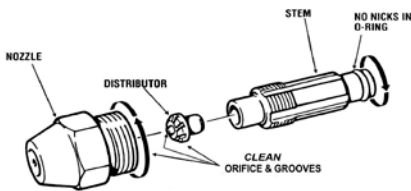

Nozzle problems such as clogging will result in a poor, small blue flame. Once the nozzle is removed from the fuel block, it can be disassembled and cleaned as part of regular maintenance. To disassemble the nozzle, position it vertically. Hold the nozzle head with a 5/8" box-end wrench, and the stem with a crescent wrench. Be sure to keep the wrench square on the stem, and do not use a tool with sharp edges, as the soft brass can damage easily. Turn the stem clockwise to unscrew it from the nozzle head. Keeping the nozzle vertical, carefully remove the nozzle head from the stem. This will expose the fuel distributor that sits in the end of the stem. Remove the o-ring from the stem. Clean all of the parts with regular automotive brake cleaner or a suitable solvent, using a rag and cotton swab. Blow air through the orifice of the distributor, stem and nozzle head. Make sure all parts are free of debris. Do not poke anything through the holes of any of the nozzle parts. Clean these only with solvent and compressed air. Reassemble the nozzle carefully, making sure the fuel distributor is seated properly in the stem. Do not over-tighten the nozzle head and stem connection. Replace the O-ring. A damaged, leaking O-ring will cause poor burning performance and possible flame-outs. Always lubricate the O-ring with a small amount of diesel fuel or silicone grease prior to replacing the nozzle into the fuel block.

13.4 Fuel Lines and Filters

Regularly inspect fuel lines for cracks, abrasion, abnormal wear, possible future damage and loose fittings or clamps. Filters should be replaced every season, even if they appear to be clean. Use a 10 micron filter to filter your main fuel supply.



13.5 Combustion Chamber

Quality of fuels vary, and some fuels may leave ash deposits in the burn chamber. The burner and combustion tube must be removed and the combustion chamber must be vacuumed clean every 1000 hours. If this is neglected, the exhaust will be restricted and will cause the combustion chamber to burn out. The exhaust pipe should be checked and vacuumed as required.

13.6 Checking Hoses and Tubes

Every so often, check the coolant hoses and tubes for leaks or weak points and make sure all clamps are tight. Replace any sections of worn hose immediately. Also check for flow restrictions and ensure that any installed bend supports are in their proper position. Check for unsupported hose or tubing and check and eliminate the potential for future problems.

13.7 Electrical System

The electronic control panel should not normally require servicing, except for the following:

- Make sure that all connections are secure.
- Periodically, do a voltage test to ensure that you are getting 12 volts from the battery.
- Check for corrosion of wires.

13.8 Recommended Spare Parts

A suggested maintenance schedule, *Figure 13-1*, lists suggested items and service intervals. The following is a list of parts recommended to have on hand:

- Fuel Filter Cartridge
- Air Filter
- Nozzle
- Nozzle Filter
- Nozzle "O" Ring
- Igniter

Over a period of time, operational parts of the heater will wear and may need replacing:

- Air Compressor
- Fuel Pump
- Flame Sensor
- Aquastats

<u>MAINTENANCE ITEM</u>	<u>MAINTENANCE FREQUENCY</u>	<u>SERVICE REQUIRED</u>
FUEL/WATER HOSES	SEASONALLY	INSPECT FOR LEAKS AND WEAK POINTS
HOSE CLAMPS	SEASONALLY	INSPECT FOR CORROSION. TIGHTEN IF LOOSE
COMBUSTION CHAMBER AND EXHAUST	1000 HOURS	VACUUM CLEAN
FUEL FILTER	SEASONALLY	INSPECT FOR CLEANING OR REPLACEMENT
NOZZLES DISTRIBUTOR ORIFICE, AIR SLOTS & O-RINGS	SEASONALLY OR 2000 HOURS	CLEAN AND INSPECT FOR WEAR AND DAMAGE
EXHAUST SYSTEM	SEASONALLY	INSPECT FOR LEAKS AND CORROSION
COOLANT MIXTURE	36 MONTHS 12 MONTHS	REPLACE CHECK pH LEVEL FOR ACIDITY
ELECTRONIC CONTROL PANEL	SEASONALLY	TEST VOLTAGE. INSPECT FOR CORRODED WIRES
AIR COMPRESSOR FUEL PUMP COMBUSTION FAN MOTOR	SEASONALLY	INSPECT FOR LEAKS, CORROSION & WEAR

Figure 13-1 Maintenance Schedule

13.9 Protecting Hydronic Heating Systems

The advantage of closed hydronic heating systems is that as long as there are no leaks, (i.e., no need to consistently add heat transfer fluid), the system reaches equilibrium. This results in minimal scale build-up and very little, if any, corrosion since after operating for a period of time, most oxygen has been "starved" out of the system fluid. Leak prevention is the single most important preventative maintenance item. Not only will a leak from the system cause damage to parts of the vehicle surrounding the system, but air will enter the system during the expansion and contraction process as the fluid heats up and cools down. Regular maintenance and prompt repair of leaks will provide years of problem-free operation from your **Oasis® Zephyr™ HW**.

Causes of Scale

Tap water is the most typical source selected for boiler fill water. This water contains dissolved solids such as magnesium and calcium which when heated becomes much less soluble and forms "scale." Scale is formed in the largest amounts where the temperature is highest in the system (i.e., the boiler or heat exchanger). As scale builds up, noise and cold spots develop, since scale plugs up water channels and acts as an insulator that impedes proper heater transfer. Use distilled water.

Acidity and Corrosion

Corrosion is the result of metal oxidizing (that is, metals reacting with oxygen-rich boiler fill water). The acidity of any liquid (including water) is a good indicator of how much corrosion will actually take place. As a rule of thumb, boiler fill water should have a pH greater than 7 and less than 10.5. The key to preventing corrosion is to make sure that the heating system is free of leaks and there is no need to replace it with fresh, oxygen rich, boiler fill water. Corrosion inside a hydronic heating system stops quite quickly as the fill water stabilizes and becomes oxygen-starved. The pH should be measured at least annually.

Since most hydronic heating systems are comprised of different metals (e.g., iron, copper, etc.), and since boiler fill water is an electrolyte (that is, it will conduct electrical current), electrochemical reactions ("galvanic" reactions) can take place. As the fill water stabilizes, however, it becomes a very weak electrolyte, so galvanic corrosion rarely becomes a problem - as long as the system remains leak-free.

Preventative Treatments

Corrosion and scale inhibitors are relatively inexpensive. Ideally, they should be applied only once, at the time of a new installation, or whenever a system has been completely drained. Boiler water treatment specialists agree that the prevention of leaks and the elimination of frequent boiler water top-up are high priorities in hydronic system maintenance.

Oasis® Zephyr™ HW Diesel Hydronic Heating System

January 2013

NOTICE

No warranty will be extended to unapproved, unauthorized or improper installations. Use of any materials or equipment unsuited for their intended use will result in a voided warranty for the entire heating system.

This Inspection Check Sheet is intended for use after the ITR heating system has been installed; it should also be used informally to monitor progress during the installation. Only authorized personnel may carry out the inspection and testing.

No rewiring of the Oasis® Zephyr™ HW is permitted unless it has been pre-approved by ITR.

1. Before Start-up **Hour Meter Reading** _____

✓	Step	1. Before Start-up
	1	The heater and all components are mounted in appropriate locations according to standards, with required clearances for maintenance. (see manual)
	2	All components, accessories and materials are ITR-manufactured or approved for their intended use.
	3	Length, routing and sizing of coolant hoses, fuel lines, air vents, combustion air intake hose, and exhaust tubing are installed and connected according to the installation guide standards.
	4	Oasis® Zephyr™ HW Heater is properly exhausted (i.e. no exhaust fumes from unit will infiltrate the vehicle interior).
	5	The combustion inlet is drawing 100% outside air and is unrestricted.
	6	No exhaust parts are close to, touching or passing through any combustible material (unless fire-protected).
	7	All exhaust connections and fittings are secure and airtight. Proper clamps are used and no hoses are kinked or pinched.
	8	Fuel supply has a dedicated pickup from main diesel fuel tank.
	9	Fuel lines do not pass through areas of excess heat and are separated from water lines.
	10	Fuel lines are secure with no risk of becoming pinched, kinked, or damaged during normal operation.
	11	All DC wiring connections are correctly secured, sized and installed according to normally-accepted wiring practices and applicable standards (ABYC/RV Standard).
	12	All AC electrical connections are correctly secured and sized to applicable standards.
	13	Fuses are correctly sized and positioned. Total amperage draw of all components are compatible with amperage supply of control board.

✓	Step	1. Before Start-up
	14	Battery connection is secure and direct from control board to house battery bank, with correct polarity.
	15	Battery connection is protected with a circuit breaker or heavy-duty fuse that is properly sized to the total system load and is protected from accidental disconnect.
	16	Heater case and all external electrical connections are properly grounded.
	17	Circulation system is full of 50/50 (recommended) mix of antifreeze and water (propylene glycol is strongly recommended).
	18	Circulation lines are properly insulated from cold and protected from solvents where necessary.
	19	Circulation pump jumper is in the unbridged position on the control board.
	20	If the engine waste heat reuse function is installed, coolant supply and return ports are correctly located, as per the engine manufacturer's recommendations.
	21	If engine pre-heat function is installed, all connections are tight and correct.
	22	Ensure expansion tank is at the highest point in the system, or there is another provision for the elimination of air from the system.
	23	Ensure air source for the cabin fans be supplied from living space or outside air only.

Comments: _____

Inspection #1 completed by: _____
Print name
Signature
Date

2. Initial Start-up

! DANGER

Never:

- Operate heater in enclosed area without adequate ventilation.
- Shut off heater power via an inline battery or master switch while system is running.
- Disconnect battery when heater is running.
- Disconnect battery when inverter is on.
- Leave heater running in bypass mode while unattended.
- Let the circulating water pump run dry.
- Operate the pump without fluid in the system.
- Mix antifreeze from engine with heater coolant.

✓	Step	2. Initial Start-up
	24	The voltage at main power feed at control board is between 11 VDC and 15 VDC.
	25	Turn on the heater at the remote panel and turn up all thermostats. If the furnace does not start, reset system by turning the remote switch off/on. When the heater tries to fire, wait until the fuel filter is full and all air is purged from the system
	26	Ensure these signs of normal operation appear immediately: <ul style="list-style-type: none"> • Circulating pump is running. • Green indicator lights on control board lights up. • Combustion air-intake fan is running. • Igniter glows orange or bright yellow. • Compressor and fuel pump turn on; fuel solenoid opens. • Furnace ignites (and igniter shuts off after thirty seconds). • Hot air comes out of the exhaust.
	27	Circulation system has been tested and purged of air: <ul style="list-style-type: none"> • fluid outlet on heater becomes warm • supply and return fluid hoses become warm (with a MAX of 30°F [17°C] difference between them when heater cycles off and only the pump is running) • no bubbling or cavitations is present If all of these conditions are not met, shut down the heater and check fluid circulation.
	28	Flow rate is checked and verified to be approximately 1 GPM per 10,000 BTU/H
	29	No leaks are present (check all hosing, connections, etc.).
	30	The overflow tank is filled to line (top up as necessary).

Comments: _____

Inspection #2 completed by: _____

Print name

Signature

Date

3. Normal Operation

✓	Step	3. Normal Operation
	31	Burner continues to operate until all zones have reached set temperature (Heater should cycle at 170°F with overheat shutdown at 190°F.).
	32	If installed, ensure the domestic hot water system operates effectively. Refer to the manual.
	33	Each interior fan operates effectively. Set Zone 1 thermostat to 10°F above ambient. If there is fan speed switch, set it to high. Furnace should fire and Zone 1 fans should come on immediately if system is at temperature. If system is cold and fans have internal aquastats, they will not turn on until the coolant reaches temperature. Set fan speed to low and confirm that speed reduces. Turn down thermostat and confirm fans shut down. Repeat for each interior zone.
	34	All interior fans operate effectively together (turn up all zone thermostats; total amperage draw of all fans must be 10 Amps or less).
	35	If installed, ensure that the freeze protection device functions correctly by finding the Low Temperature Thermostat (normally located on or immediately adjacent to the fresh water tanks). With the heater enabled, hold an ice-cube to the contact surface of the device. The heater should come on and run in less than one minute from the initial contact.
	36	Check to see if the heater shows a Code 7 on flame out by blocking the compressor air intake. Keep the intake blocked after the initial shutdown to confirm that the heater makes two attempts to relight, that the fault buzzer sounds at the Remote Panel, and that Code 7 appears on the control board display. The digital diagnostic panel should read, " <i>Flame Out, See Service Book...</i> "
	37	If installed, ensure the engine waste heat recycling function works correctly. Start the engine and bring it up to normal operating temperature. Turn on the thermostat and check that heat comes out of the vents.
	38	If installed, ensure the engine pre-heat function works correctly. With the heating system at temperature, turn on the pre-heat pump switch. Engine temperature should change within 15 minutes.
	39	If the heater cycles off on its own, ensure the combustion fan and the circulating pump continue to operate for another two minutes to purge the burner.

Comments: _____

Inspection #3 completed by: _____

Print name

Signature

Date

4. Shutdown

✓	Step	4. Shutdown
	40	Ensure that when the heater is turned off at the remote indicator panel, the heater runs through its two minute purge cycle.
	41	Check that with all systems off and no call for heat, the system shuts down completely after purging (two minutes).
	42	All fluid levels have been checked and topped up after cool-down.
	43	When the service switch is turned off (on side of electrical control box), the heater runs through its two minute purge cycle.
	44	Make sure that if the heater will not be operated during low temperature conditions, the domestic water system has been drained to avoid freezing.

Hour Meter Reading at completion of check out _____

Comments: _____

Inspection #4 completed by: _____
Print name Signature Date

Heater Model and Serial No.

Type of Installation

Cubic Volume of Heated Areas

Owners Name / Address / Telephone Numbers

Supervisor and final sign-off: _____
Print name Signature Date



Warranty Information

Attention Purchaser and Installer

General Warranty

- ITR warrants the OASIS® CH50, COMBI and ZEPHYR HW(referred to as "heater(s)") DISTRIBUTION MODULE and all accessories or other supplied components with the original purchase to be free of defects in materials and workmanship under design usage and service conditions for ONE (1) year from the heater "in-service" date. Warranty replacement parts are covered for the remainder of the heater's warranty.
- You must install the Product in compliance with the specifications, standards, and instructions in the *Installation Manual*.
- If you need to depart from the manual, you must first consult and obtain the written approval of ITR. Otherwise, your warranty may be voided or limited.
- Systems that are not installed to the published installation instructions (unless with prior written approval of ITR) will be ineligible for warranty coverage.
- Fill in the enclosed Warranty Card completely. It must be signed by the Owner and returned to ITR within 30 days of the date of the original installation. The Owner cannot transfer this warranty. Before mailing, make photocopies of the completed Warranty Card for your records. It will be a valuable reference if you need warranty repairs in the future.

Limited Warranty

The following warranties are in lieu of all other warranties and conditions. ITR makes no other warranties, representations, or conditions, express or implied. Expressly excluded are all implied or statutory warranties or conditions of merchantability of fitness for a particular purpose, and those arising by statute or otherwise in law or from dealing or trade usage.

The stated express warranties are in lieu of all liabilities or obligations for damages arising out of or in connection with the delivery, use, performance, or licensing of the Product or in connection with any services performed. In no event whatsoever will ITR be liable for indirect, consequential, exemplary, incidental, special, or similar damages, including but not limited to, lost profits, lost business revenue, failure to realize expected savings, other commercial or economic loss of any kind or any claim against ITR by any other party arising out of or in connection with the sale, delivery, use, performance, or repair of the Product, or in connection with any services performed, even if ITR has been advised of the possibility of such damages, whether based upon warranty, contract, or negligence. ITR's maximum liability shall not in any case exceed the contract price for the Products claimed to be defective.

No one is authorized to increase, alter, or enlarge ITR's responsibilities or obligations under these warranties.

Owner's Responsibilities

If any warrantable failures occur before the expiration of the warranty, the Owner must give notice of such failures to ITR or to the authorized ITR dealer from which the Product was originally purchased, and obtain written approval for the warranty repair.

The Owner is responsible for the following costs in case of a warrantable failure:

- shipping and insurance costs to deliver the defective Product to the dealer or ITR (if necessary)
- all repairs made to equipment ancillary to the Product, including the vehicle, coach engine, and other associated components of the vehicle in which the Product is installed
- lodging, meals, and other incidental expenses incurred by the Owner as a result of a warrantable failure
- "down time" expenses and all business costs and losses resulting from the warrantable failure

Not Covered Under Warranty

Warranty will be voided or not extended in the following circumstances:

- Owner fails to notify ITR or the authorized ITR dealer from which the Product was originally purchased about a warrantable failure and to obtain prior written approval for warranty repair.
- Original serial number on Product or electrical control board has been removed, altered, or is unreadable.
- Product has been modified or uses non-standard parts not approved by ITR.
- Product has been abused (such as by dropping it), damaged, vandalized, or has received improper maintenance.
- Product has been run dry or operated without appropriate antifreeze, causing damage to the heat exchanger, pump seals, etc.
- Product has been exposed to an environment detrimental to its effective operation, such as excessively wet, dirty, or hot areas.

Also not covered under warranty:

- Parts or Products no longer within the manufacturer's warranty period.
- Parts or Products installed or used in a manner contrary to ITR's printed instructions without ITR's prior written permission.
- Normal wear and tear of parts, including but not limited to, fuel filter, air filter, nozzles, fuses, ignitor, electrical motors, fuel pumps, air compressors, and carbon brushes.
- Product malfunctions due to improper installation of parts or Products, including but not limited to malfunctions causing inadequacies in air, fuel, or coolant flow; voltage problems due to improper wiring; and shock or vibration.

- Progressive damage to the engine or vehicle caused by failure of the Product or an improper installation.
- Diagnosis or repairs to fix problems not directly related to the Product or due to empty fuel tanks or poor fuel quality, fuel additives, acidic water, electrolysis, or any chemical reactions.
- Travel time and expenses by an ITR dealer.
- Removal and re-installation expenses for the ITR heater.

Customer Service Calls

ITR warrants the ITR heater and the Dealer warrants the installation.

If you have a service problem, first check the *Troubleshooting* section of the *Owner's Manual* to determine if your problem is addressed. Also ensure you are familiar with the design and installation setup.

When calling ITR or the Dealer with a service problem, have the following information ready at hand:

- model number and serial number of the Product
- a detailed description of the problem
- your *Installation Manual* and *Owner's Manual*

Depending on your location, an authorized service person may be able to visit your coach or yacht to help troubleshoot problems and repair your Product. Such service calls are at the Owner's expense. Regardless, you must obtain written approval from ITR or the Dealer for any warranty repair before it is undertaken. All repairs done under warranty are subject to the terms and conditions of the flat-rate manual.

Returns

If a service call by an authorized service person is not feasible, the Owner must do the following to obtain warranty service:

1. Immediately contact ITR (or your Dealer) and provide a full description of the problem.
2. Obtain (in writing) a Return or Repair Material Authorization (RMA) number from ITR for any warranty, return, repair, or service. ITR will refuse any return package and will not authorize service or repairs without a RMA number. (For repairs by authorized Dealers, the dealer must obtain an authorized RMA number from ITR before warranty work commences.)
3. When shipping your Product, pack securely, show the RMA and serial number of the Product on the outside of the shipping container, and ship prepaid and insured.
4. Provide written details of the problems, date of installation, proof of purchase, and a return address.

After repair or replacement of the Products still under warranty, ITR will pay return shipping charges. All repairs done under warranty are subject to the terms and conditions of the flat-rate manual.

Telephone / Email Service

Service information given over the telephone, by fax or by email is given only in good faith as an accommodation to the customer. Such information should not be relied upon without an independent verification of its applicability to the customer's particular situation. For customer service or other information, contact:

IN CANADA:

2431 Simpson Road
Richmond, BC, Canada V6X 2R2
Tel: 1-800-755-1272 or 604-278-1272
Fax: 604-278-1274
Email: info@itrheat.com

IN THE UNITED STATES:

11915 NE 56th Circle, Suite B
Vancouver WA USA 98682
Tel: 1-800-993-4402 or 360-993-4877
Fax: 360-993-1105
Email: info@itrheat.com

Website: <http://www.itrheat.com>

OWNER'S SERVICE LOG:

Date	Service Performed	Service Center