

**INTERNATIONAL LTD
THERMAL RESEARCH**

OASIS[®] NE-S Heating System

Installation and Operating Manual

**Diesel and AC Heating System
for Recreational Vehicles and Yachts**



CAN/CSA-C22.2 No.110-94 (R2014)
CSA B140.10-06 (R2015), CSA B140.0-03 (R2013)
UL307A (Edition 8), UL174 (Edition 11)

Copyright © September 2016

International Thermal Research

IN CANADA:

2431 Simpson Road

Richmond, BC, Canada V6X 2R2

Tel: 1-800-755-1272 or 604-278-1272

Fax: 604-278-1274

Email: info@itrheat.com

IN THE UNITED STATES:

11915 NE 56th Circle Suite B

Vancouver, WA, USA 98682

Tel: 1-800-993-4402 or 360-993-4877

Fax: 360-993-1105

Website: <http://www.itrheat.com>

All rights reserved. No part of this manual may be reproduced or transmitted in any form by any means, electronic or mechanical, including photocopying and recording, information storage, retrieval, or transmission, without permission in writing from International Thermal Research

Right to Modify:

Due to our commitment for quality and ongoing product improvement, ITR reserves the right to modify or change without notice, any materials, applications, equipment, accessories, and/or prices. All measurements and weights are approximate.

Table of Contents

Section 1, Overview 1-1

1.1	Unpacking the Oasis® NE-S Heating System	1-2
1.2	Protect Your Warranty.....	1-2
1.3	Oasis® NE-S Heating System Features	1-3
1.4	Critical Factors	1-5
1.5	Equipment, Tools and Skills	1-6
1.6	Testing and Inspection	1-7

Section 2, Mounting the Oasis® NE-S Heating System 2-1

2.1	Before You Begin.....	2-1
2.2	Identifying Your Oasis® NE-S Heating System Model	2-2
2.3	Your Mounting Location.....	2-2
2.4	What NOT to Do	2-4
2.5	Oasis® NE-S Mounting Procedure.....	2-4
2.6	Zone Control Board Mounting Procedure.....	2-5
2.7	Remote Operating Panel Mounting Procedure....	2-6

Section 3, Installing the Exhaust System 3-1

3.1	Before You Begin.....	3-1
3.2	Mounting Location	3-1
	Recommended Exhaust Outlet Locations.....	3-1
	Recommendation for Installation	3-2
	What NOT to Do	3-4
3.3	Procedure.....	3-4

Section 4, Installing the Fuel System 4-1

4.1	Before You Begin.....	4-1
4.2	Fuel System Installation.....	4-1
	Recommendations for Installation	4-1
4.3	What NOT to Do	4-2
4.4	Procedure.....	4-3

Section 5, Installing Fan Heaters..... 5-1

5.1	Before You Begin	5-1
5.2	Fan System Operation	5-2
	Features	5-2
	Multiple Zone Heating.....	5-3
	Accessories and Components Needed	5-3
5.3	What NOT to Do	5-4
5.4	Mounting Locations	5-4
5.5	Procedure	5-5

Section 6, Wiring the Electrical System 6-1

6.1	Before You Begin	6-1
6.2	Oasis® NE-S 12 VDC	6-2
6.3	Oasis® NE-S 120 VAC.....	6-3
6.4	Wiring the Zone Control Board	6-4
6.5	What NOT to Do	6-5

Section 7, Plumbing the System 7-1

7.1	Before You Begin	7-1
7.2	Coolant Plumbing Installation	7-2
7.3	What NOT to Do	7-4
7.4	Coolant Plumbing Installation Procedure	7-5
7.5	Potable Water Plumbing Installation	7-6
7.6	Engine Plumbing Installation	7-7
7.7	Procedure For Filling/Purging The Oasis® NE-S Heating System	7-8

Section 8, Operating the Oasis® NE-S Heating System 8-1

8.1	Features of your Oasis® NE-S Heating System ..	8-1
8.2	Operating Instructions for the Oasis® NE-S Heating System	8-3
8.3	Turning the Power to the Oasis® NE-S Heating System ON	8-4
8.4	Activating the Burner (Primary) and AC Heat (Secondary) from the Remote Operating Panel.....	8-5
8.5	Activating the Cabin Fan Heaters through the Thermostats.....	8-6
8.6	Activating the Potable Hot Water	8-6
8.7	Potable Water Temperature Adjustment	8-7
8.8	Activating Engine Heat & Pre-heat	8-8
8.9	Functions of the Remote Operating Panel	8-9
8.10	Functions of the Oasis® NE-S Control Panel	8-11
8.11	Functions of the Zone Control Board	8-12
8.12	Potable Water and Space Heating Priority	8-14
8.13	Maintenance	8-15
8.14	Protecting the Heating System	8-16
8.15	General Troubleshooting	8-17

Warranty Information & Warranty Card

List of Figures

Figure 1-1	Oasis® NE-S Heating System	1-1
Figure 1-2	Oasis® NE-S Heating System Overview	1-5
Figure 2-1	Oasis® NE-S Dimensions	2-3
Figure 2-2	Oasis® NE-S Mounting Brackets	2-5
Figure 2-3	Zone Control Board	2-6
Figure 2-4	Remote Operating Panel Mounting.....	2-6
Figure 3-1	Installing the Exhaust System (Bottom Exhaust).....	3-6
Figure 3-2	The Exhaust Hole Location & Mounting Template	3-7
Figure 3-3	The Exhaust Goose Neck Configuration	3-7
Figure 5-1	Wiring the Fan’s Aquastat.....	5-2
Figure 5-2	Mounting a Low Profile Cabin Fan	5-6
Figure 5-3	Installing a Relay for Add’l Fan Amperage ...	5-6
Figure 6-1	System Wiring	6-2
Figure 7-1	Oasis® NE-S Heating System Overview	7-3
Figure 7-2	Plumbing Oasis® NE-S For 5 Zones.....	7-3
Figure 7-3	Three Approved Methods of Installing Heater Hose (consult ITR for alternative methods and products)	7-6
Figure 7-4	Potable Hot Water System Plumbing.....	7-7
Figure 7-5	Engine Heat / Pre-heat System Plumbing	7-8
Figure 7-6	Filling/ Purging Oasis® NE-S Heating System Engine Heat/ Pre-heat System Plumbing	7-9
Figure 8-1	Oasis® NE-S Heating System Overview	8-3
Figure 8-2	Oasis® NE-S Main Control Panel	8-4
Figure 8-3	Mixing Valve Location	8-7
Figure 8-4	Remote Operating Panel.....	8-9
Figure 8-5	Zone Control Board	8-13
Figure 8-6	Zone Control Board Priority Jumper	8-14

Overview

Thank you for purchasing the Oasis® NE-S Heating System for recreational vehicles and yachts (for use on vessels over 65 feet in length).

NOTICE

The Oasis® NE-S Heating System is CSA/UL certified only for installation into Recreational Vehicles, Manufactured Homes, and Mobile housing.

This section covers critical information you need to know before beginning the installation including how to protect your Warranty, and tools and equipment needed.



Figure 1-1: Oasis® NE-S Heating System

1.1 Unpacking the Oasis[®] NE-S Heating System

When you receive the Oasis[®] NE-S Heating System:

- 1 Unpack it carefully.
- 2 Check each component against the shipping list to ensure that you have everything and that all parts arrived undamaged.
- 3 If you discover any missing or defective parts call ITR immediately.
- 4 If you are not installing the Oasis[®] NE-S Heating System right away, secure all components so none will be misplaced.
- 5 **Before installing the Oasis[®] NE-S Heating System read the rest of this Installation and Operating Manual. It contains critical information for a proper installation.**

A properly installed Oasis[®] NE-S Heating System is essential for several reasons:

- To ensure that you and/or your customers receive satisfactory results and enjoy a warm, comfortable environment.
- To ensure a trouble-free installation, a successful inspection and testing process, and ease of future maintenance.
- To protect your Warranty.

1.2 Protect Your Warranty

This document reflects approved installation techniques, methods, and materials, and applies only to ITR equipment. The Oasis[®] NE-S Heating System is only guaranteed by ITR if the entire system has been installed according to the requirements and recommendations set out here.

This includes:

- Deviations from the instructions in this Manual.
- Changes to any piece of ITR-supplied equipment.
- Substitution of a non-ITR approved component.

No Warranty will be extended to improper installations. Use of any unapproved materials, equipment or installation procedures will result in a voided warranty for the entire heating system. Any loss of service or damage as a result of any unapproved modification is the responsibility of the installer. ITR accepts no liability for any damage or loss of service resulting from unapproved modifications.

- Efficient
- Clean
- Quiet
- Compact
- Safe
- Rugged
- Reliable
- Economical

1.3 Oasis[®] NE-S Heating System Features

The Oasis[®] NE-S Heating System uses an 85,000 BTU (true output) diesel burner (12 VDC) controlled by a multi-functional electronic controller as the primary source of heating coolant fluid (anti-freeze and water). Two 1500 Watt, 120 VAC immersion elements are used as secondary heat sources to provide an additional 10,000 BTU of heat. The Oasis[®] NE-S Heating System heats the coolant fluid to provide a source of heat for all hydronic space heating needs. Through the use of its integral distribution pumps, the Oasis[®] NE-S Heating System has the ability to circulate the coolant fluid to all space heating areas. It can also provide a supply of domestic hot water using the integral heat exchanger. The Oasis[®] also incorporates engine heat and preheat functions. (see *Figure 1-2: Oasis[®] NE-S Heating System*).

Other features of the Oasis[®] NE-S Heating System include:

- Built in distribution pumps and heat exchangers for heating multiple zones and also producing domestic hot water. Heat exchanger also allows engine pre-heating (optional) as well as using engine waste heat. The Zone Board Controls up to five space heating zones.
- Support for high flow potable hot water demand. The mixing valve is factory set to limit the maximum temperature of the heated water to 120°F (49°C) with a total hot water demand of 3.0 GPM or less, and an incoming water temperature of 60°F (15°C) or higher.
- Easy to install and field serviceable with system hookups and connections easily accessible from the top of the heater.
- Easy to fill and purge zero pressure system.
- Easy to drain.

- A high-temperature, stainless steel burner and stainless steel jacket.
- 14 US gallon, welded, insulated stainless steel coolant tank that minimizes heat loss and optimizes heat recovery.
- Domestic water flow switch for quick response to domestic hot water demand.
- Low coolant level switch.
- Quiet operation and low power consumption.
- Low pressure fuel system with built-in fuel pump.
- Fuel efficient burner capable of burning a wide variety of diesel-based fuels (CSA/UL certified for diesel #1 and #2).
- Exhaust has minimal smoke and smell.
- Fan assisted sealed combustion chamber is designed to use outside combustion air.
- Low amperage draw ignition.
- Electronically-controlled system featuring:
 - automatic Safety Shutdown;
 - manual-resettable aquastats for safety overheat protection.
 - LED indicators on the Control Panel for diagnostics.
 - Patented, proprietary flame sensor.
- Remote Operating Panel with ON/OFF switch for the diesel burner, AC elements, and engine pre-heat, if installed.
- Control Panel with buttons for Power, Bypass, Reset, and indicator LED's for operational and diagnostic information.

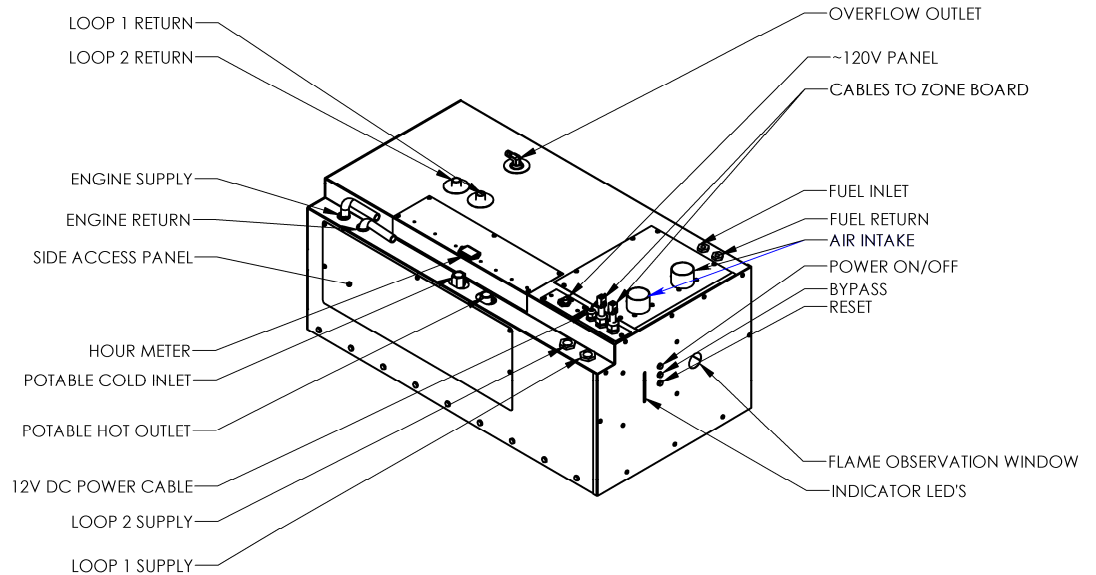

Figure 1-2: Oasis® NE-S Heating System Overview

1.4 Critical Factors

THE INSTALLATION SHALL BE IN ACCORDANCE WITH THE REGULATIONS OF AUTHORITIES HAVING JURISDICTION

Pay attention to the notices of "Danger" "Warning" "Caution" and "Notice" in this manual.

The key factors to keep in mind when planning and carrying out the installation are:

- Mounting location restrictions for the Oasis® NE-S Heating System and exhaust outlet (to reduce noise, vibration, heat loss, etc.).
- Length, routing and sizing of fluid lines, air-flow tubing, exhaust piping and wiring.
- Unrestricted vent required to draw in 100% outside air for combustion.
- Ability for technician to easily access and service the product, especially fuel, plumbing, and electrical systems.
- After installation, ability to purge water and fuel lines and inspect/test entire system using the ITR-supplied Inspection Check Sheet.

1.5 Equipment, Tools and Skills

As the user and/or installer, you must be qualified and authorized to do the installation, which requires mechanical aptitude and electrical knowledge. Make sure you comply with existing RVIA or ABYC (for yachts) industry practices, using the highest and most recent standards and codes. Good workmanship is essential. Please refer back to *Section 1 – Overview, sub-Section 1.2, Protect Your Warranty*.

You will need the following equipment and tools to install the heating system (not supplied). This list does not include optional equipment and accessories:

- Standard tools normally available in a well-equipped shop.
- Approved fasteners for mounting the heater unit.
- Steel (or stainless steel) 2" ID exhaust system piping, maximum 12' with no bends. (See *Section 3 – Installing the Exhaust System*, for details when bends are present.).
- Exhaust collar.
- ITR-muffler with straight-through design.
- Two 2" air intake collars for connecting fresh outside air
- Two 2" air intake hoses for connecting to fresh air intakes of the Oasis NE-S.
- 1/4" supply fuel line, approved rubber or copper.
- #10 sheet metal screws or wood screws to mount fan units inside the occupied areas.
- Heater hose (to connect Oasis NE-S hose fittings to interior fans).
- Potable water hose/PEX to connect the Oasis NE-S potable water hose/PEX fittings to the domestic water system.
- Overflow tank to connect to the Oasis[®] Heating Module with clear plastic 5/8" hose; tank must be made of heavy-duty plastic, vented with a screw-down cap, have an overflow outlet, and sturdy enough to mount firmly to a vertical surface.

- Up to five (5) thermostats (DC compatible) to allow temperature regulation of the heating zones.

1.6 Testing and Inspection

After all components have been properly installed according to standard practices, RVIA or ABYC (for yachts) standards, and the recommendations of this Installation and Operating Manual, the Oasis® NE-S Heating System should be test-operated for inspection purposes.

For your convenience, you can use the pullout *Inspection Check Sheet* in this Manual. The Inspection Check Sheet is divided into progressive sections, allowing each phase of the inspection to be carried out systematically, and then signed off by authorized persons.

Mounting Oasis[®] NE-S Heating System



2.1 Before You Begin

Plan the location of the Oasis[®] NE-S Heating System and all its major components in advance to ensure the chosen locations are compatible with installation requirements and within the technical specifications.

Consider the following factors to help you decide exactly where best to mount the Oasis[®] NE-S Heating System:

- Oasis[®] NE-S Heating System weight when full (256 lbs).
- Ventilation requirements.
- Exhaust outlet location and maximum acceptable length, including all 90 degree bends. Refer to section 3.2.
- Thru hull location and waterline (yachts). Refer to section 3.2.
- Potential for vibration and jarring.
- Length of run from fuel source to heater. Refer to section 4.2.
- Most efficient plumbing runs.
- Safe and convenient access for maintenance.
- Number and location of interior fans.
- Location of other equipment to be installed or connected to the Oasis[®] NE-S Heating System, including the Zone Control Box, heat exchangers, overflow tank, batteries, etc.

! WARNING

Make sure you are familiar with *Section 1 – Overview* of this Manual. If the system is not installed according to specifications and with the correct equipment, your Oasis® NE-S Heating System may not operate properly, safety may be compromised, and your Warranty may be voided.



2.2 Identifying Your Oasis® NE-S Heating System Model

As the owner, you must be fully aware of the controls and operating features particular to your model of the Oasis® NE-S Heating System. This is essential for the proper functioning and life of your Oasis® NE-S Heating System as well as protecting your warranty. Your model can be identified by locating the serial number label on the outside case of the Oasis® NE-S Heating System. The serial number identifies the model type through the first series of letters and numbers.



2.3 Your Mounting Location

Your mounting location should consider the following:

- Mounting location must be able to support double the gross weight of the Oasis® NE-S Heating System (i.e. 256 lbs. x 2 = 512lbs. /116 KG x 2 = 232 KG) and must be of a non-combustible and non absorptive surface.
- Oasis® NE-S Heating System is 15.3”H x 19.1”W x 36.1” D. (38.86 cm x 48.5 cm x 91.7 cm), see *Figure 2-1: Oasis NE-S Dimensions*.
- Oasis® NE-S Heating System must be installed in a compartment which is completely isolated from the atmosphere of living spaces.
- Combustion air must be drawn from an outside source and cannot contain any combustible gases.

Section 2, Mounting the Oasis[®] NE-S Heating System

- Mount the unit with the front panel facing out and accessible. This mounting position simplifies installation and maintenance. Leave the left side of the unit accessible for maintenance.
- The Oasis[®] NE Heating System must be mounted in an area that provides unrestricted access to the front and left side panels. Allow space for connection to the fuel, coolant, and potable water lines, as well as the power, exhaust, and air intake connections. The following are the minimum required clearances: 8" top clearance, 12" front clearance, 12" left side clearance; 0" clearance to all other Oasis[®] NE Heating System surfaces. Allow 1" clearance on the right side for attaching the mounting brackets.
- Oasis[®] NE-S Heating System must be mounted horizontal and level using eight, 1/4" through bolts and 1" diameter fender washers, lock washers and nuts.

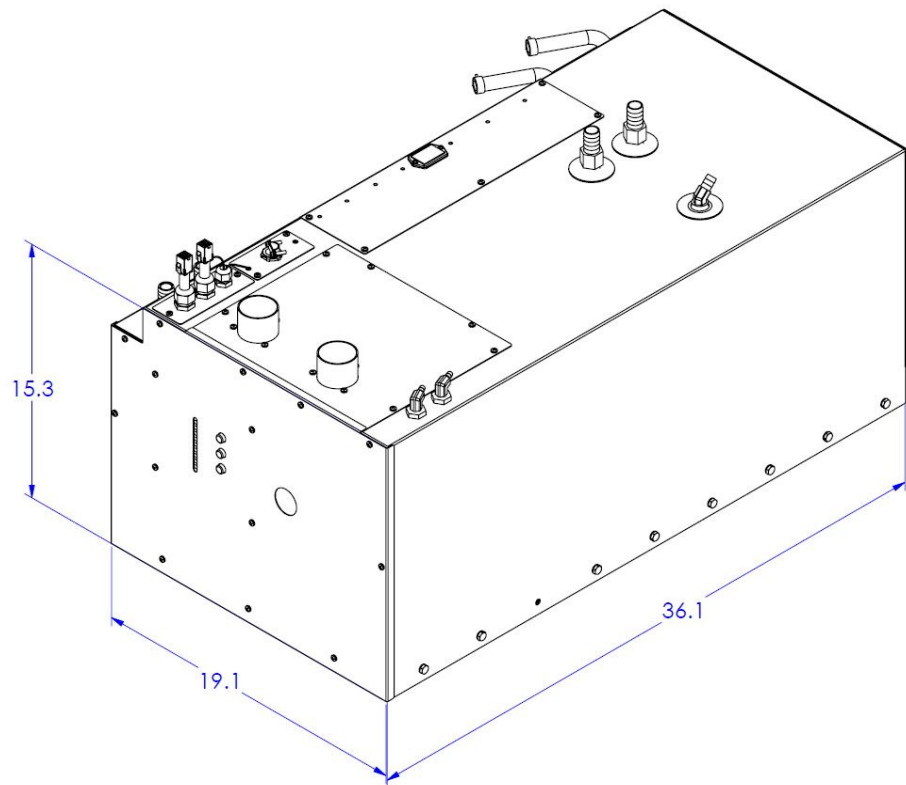

Figure 2-1: Oasis[®] NE-S Dimensions

! DANGER

Oasis® NE-S Heating System must not be installed or operated in any compartment with flammable gases.

! WARNING

If the Oasis® NE-S Heating System is going to be mounted in the engine compartment, check for adequate ventilation. When the engine is running this area could be under a negative pressure. Make sure the air-intake and exhaust hoses have no leaks and are well fastened to the heater, muffler and thru-hull fitting. Assembly parts that may cause injury through accidental contact should be protected.

! DANGER

This is a direct vent system. The combustion air must be drawn directly from the outside, without coming in contact with air that can infiltrate the living areas. See section 3.3.

- It is recommended that a catchpan be placed under the Oasis® NE-S Heating System to contain any unexpected leak.
- Choose a sturdy surface in a location that won't be unduly affected by vibration and jarring from rough roads or rough seas.
- Ensure that the exhaust tubing can be properly and safely routed to the outside. The maximum exhaust run for the system is 12', including 90 degree bends. See section 3.2.



2.4 What NOT to Do

- **Don't** mount the Oasis® NE-S Heating System in the rear of the coach or yacht underneath the sleeping area. The sound of the Oasis® NE-S Heating System cycling on and off may disturb light sleepers.



2.5 Oasis® NE-S Mounting Procedure

After choosing the mounting location for the Oasis® NE-S Heating System, mount the unit and ensure it is level. Secure the Oasis® NE-S Heating System in place (against the wall, floor or a mounting platform) using four (4) mounting brackets, eight (8) x

1/4" through bolts (or wood screws), and 1" diameter fender washers, lock washers, and nuts. (See Figure 2-2: Oasis NE-S Mounting Brackets.).

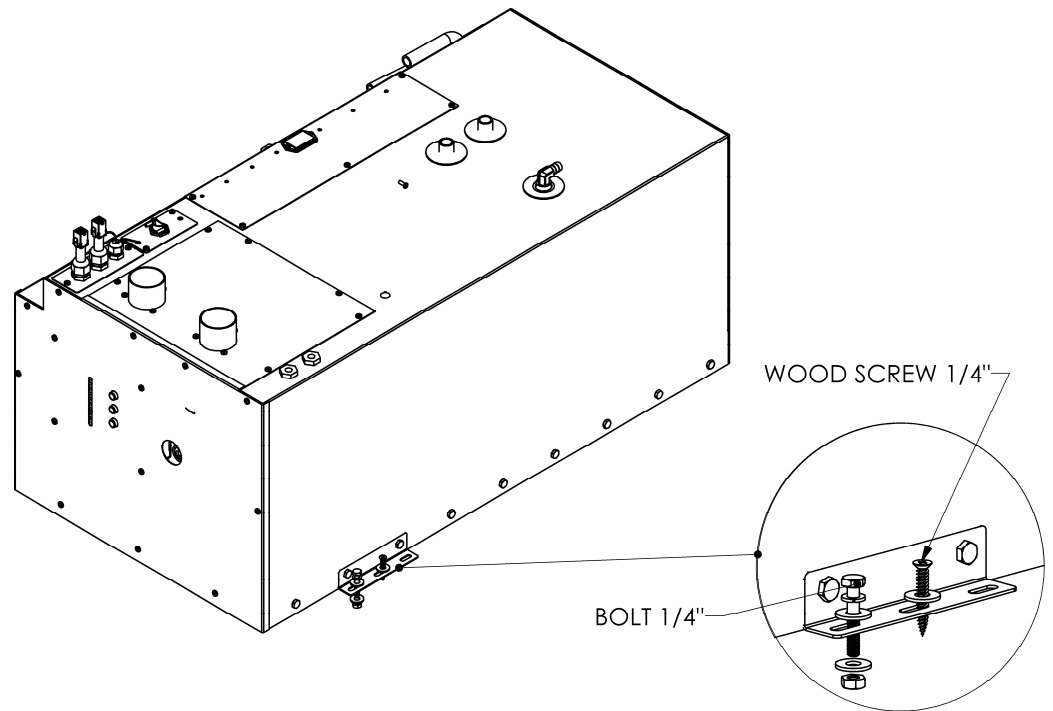

Figure 2-2: Oasis® NE-S Mounting Brackets

2.6 Zone Control Board Mounting Procedure

- Mount the Zone Control Box (containing the Zone Control Board) vertically, close to the Oasis® NE-S. Allow sufficient room to access the internal fuses as well as to view the display LED's on the front of the board.
- Mount the bracket against a wall using 2 flat head screws. The distribution module zone box will then click onto the bracket. See Figure 2-3.

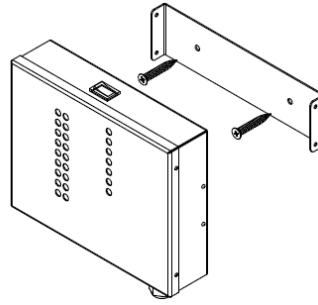

Figure 2-3: Zone Control Board

2.7 Remote Operating Panel Mounting Procedure

The Remote Operating Panel is mounted inside the Coach or Yacht, in an easy to access location. An opening for the remote panel must be cut in the wall or mounting panel. The Remote Operating Panel will be screwed in place using the 4 mounting holes.

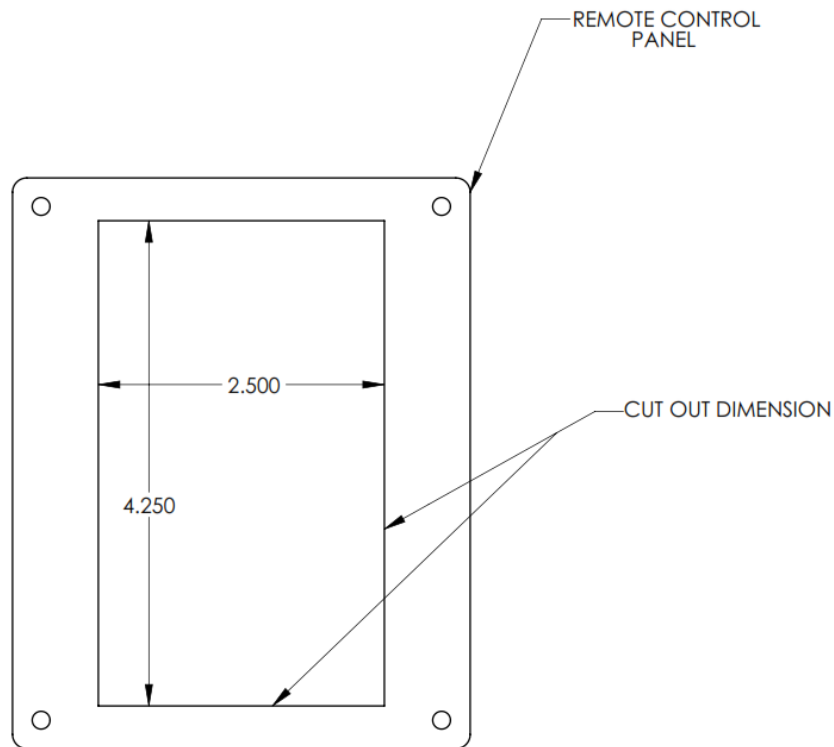

Figure 2-4: Remote Operating Panel Mounting

Installing the Exhaust System



3.1 Before You Begin

For efficient and safe operation of the Oasis[®] NE-S Heating System follow all recommendations for properly installing the exhaust. Any deviations from these must be approved in advance by ITR.

! DANGER

Although the heater's exhaust produces very low carbon monoxide emissions, caution is still advised:

- Do not operate the Oasis[®] NE-S Heating System in an enclosed area unless there is adequate ventilation.
- This is a direct vent system. The combustion air must be drawn directly from the outside, without coming in contact with air that can infiltrate the living areas. See section 3.3.

Never place any exhaust parts close to combustible material or through a combustible wall or ceiling without fireproof protection. The exhaust can reach high temperatures.

3.2 Mounting Location

If you can't meet the technical specifications for mounting the exhaust, don't use the Oasis[®] NE-S Heating System. The unit may perform poorly or become damaged if not installed according to specifications.



Recommended Exhaust Outlet Locations

The following is recommended for a coach exhaust outlet location:

- Mount the exhaust outlet **outside** the coach, not inside the heater compartment. Otherwise, exhaust fumes could infiltrate the coach from the Oasis[®] NE-S Heating System.

- When mounting the Oasis[®] NE-S Heating System in a coach, the typical mounting location for the exhaust outlet is under the floor of the heater compartment and out from the side of the coach, or out from the other side of the coach, directly across from the heater. The Oasis[®] NE-S Heating System will allow a maximum of 12' of exhaust piping, without any bends (excluding the exit bend from the heater).
- Position the outlet of the exhaust pipe so that the exhaust exits out from under the side of the coach, not directly underneath the coach or under an opening window or vent.
- If the exhaust is mounted under a slide-out, the outlet of the exhaust must be a minimum of 36" (inches) below the slide-out, including skirt and moldings.

In a yacht installation, the following is recommended for the exhaust outlet location:

- Mount the exhaust thru hull so that the exhaust fumes cannot enter or re-infiltrate any living areas.
- Make sure that the thru hull is at least 30" above the water line with a goose neck rise on the exhaust to help eliminate water from entering the Oasis[®] NE-S through the exhaust. If the dual exhaust air-intake thru hull is used, ensure that the air-intake is placed between 10 o'clock and 2 o'clock and also goose-necked to avoid water ingestion, see *Figure 3-3: The Exhaust Goose Neck Configuration*.
- There needs to be a 1/8" air gap around the exhaust thru hull. The standard thru hull is 4" in diameter. The hole for the fitting should be 4-1/4". Make sure that the holes for the mounting screws have enough material left to hold the screws firmly. The fitting must be centered in the hole.



Recommendation for Installation

The following applies to both a coach and yacht:

- You may use sweeping bends, but each 90° bend is equivalent to two feet of exhaust piping. For example, if you use two 90° bends, you must subtract 2' per bend from the maximum allowed 12' exhaust length. Therefore, you will be restricted to 8' of straight exhaust piping plus the two bends. Do not exceed these recommendations.

Section 3, Installing the Exhaust System

- The combustion air must be drawn from outside the coach or yacht. The maximum length of each air-intake tubing is 7 feet. Do not exceed this recommendation.
- Use an ITR-manufactured muffler with a straight-through design. No other muffler is acceptable.
- Exhaust outlet is on the bottom of the Oasis[®] NE-S Heating System, towards the back.

! DANGER

The exhaust and outlet are HOT and the surrounding areas must be thermally shielded and protected from the hot surfaces and heat build-up by insulation. Nothing can come into inadvertent contact with any part of the exhaust system.

- Exhaust must have a minimum of 3" (7.6 cm) clearance from all surfaces.
- Ensure that the exhaust cannot be plugged or restricted.
- The exhaust fitting on the Oasis[®] NE-S Heating System is 2.0" O.D. and the exhaust pipe used must have a minimum of 2.0" I.D. throughout its length.
- All exhaust elbows must be of a large radius design.
- The exhaust run must be supported a minimum of every 3' of its installed length.
- The exhaust and Oasis[®] NE Heating System connection point must use appropriate clamps and sealing compound to ensure that the connections are tight and leak free. Make sure any sealing used does not restrict the exhaust flow. The Oasis[®] NE Heating System exhaust outlet pipe and the exhaust pipe itself must not be distorted or damaged during this process.
- When the Oasis[®] NE-S Heating System is running the connection points and the system must be checked for leaks and any found must be corrected. Periodically, check the exhaust fittings, connections, exhaust tube, and insulation for leaks and integrity; make repairs or replacements if necessary.
- Appropriate exhaust insulation must be used to cover the entire length of any interior exhaust run.

- Solid stainless steel exhaust tubing or approved exhaust tubing is recommended but an approved stainless steel flexible exhaust tubing can also be used. If flexible exhaust tubing is used, the exhaust tubing must be inspected regularly for leaks and deterioration as this type of exhaust does not have the life expectancy of solid tubing. U-bolt clamps are recommended for joining flex and solid tubing as they apply firm, even pressure.
- In a coach, install an exhaust collar on the exhaust pipe to isolate the pipe from the coach frame. This reduces vibration and noise and protects the coach from the effects of high exhaust temperature, see *Figure 3-1: Installing the Exhaust system (Bottom Exhaust)*.



What NOT to Do

Don't mount the exhaust pipe inside the heater compartment.

Don't use more than 8' of exhaust pipe if 180° of total bends are present, excluding the one bend at the outlet of the heater.

Don't use any mufflers not supplied or approved by ITR.

Don't use too much muffler cement or exhaust sealant that you block the exhaust system.

Don't over-tighten exhaust clamps or you may crush the Oasis® NE-S Heating System's exhaust outlet pipe.



3.3 Procedure

Figure 3-1: Installing the Exhaust System (Bottom Exhaust) shows a standard setup for the down exhaust.

To install the exhaust system:

- 1 Leave suitable air spacing to protect combustible materials; use an exhaust collar and metal shields where required.
- 2 Find an appropriate location for the exhaust hole of the heater. (See Figure 3-2)

Section 3, Installing the Exhaust System

- 3** Securely seal the exhaust piping to the Oasis[®] NE-S Heating System fitting using an approved exhaust clamp.
- 4** Connect the exhaust piping in series with the muffler, using heavy-duty exhaust clamps. If you use vibration isolation mounts they must be high temperature.
- 5** Connect the flexible air-intake tubing (2" I.D.) to the air-intake fitting on top of the heater. Use a #32 gear clamp to attach the tubing to this fitting.

The other end of the air-intake hose can be installed in 2 configurations:

Installation of the air-intake adapters to the underside of the RV

Locate a suitable location to mount the air-intake adapters. Drill two, 2" holes through the floor. Insert the adapters from underneath and use 3 screws to secure each one against floor. The air entrance of the air-intake assembly shall be guarded or shielded to exclude rain, snow and debris. Use a #32 gear clamp to attach each air-intake tubing from the heater to each of the adapters. Ensure the run of tubing is as short as possible to facilitate air flow. See figure 3-1.

Installation of the air-intake adapter to the side of the RV

Locate a suitable location to mount the air-intake adapters. Drill two, 2" holes through the side wall (minimum ¼", maximum 2" wall thickness). Insert the adapters and use 3 screws to mount each one against side wall. Use a #32 gear clamp to attach each air-intake tubing from the heater to each of the adapters. Ensure the run of tubing is as short as possible to facilitate air flow. See figure 3-1.

- 6** Secure both ends of each air-intake tubing with properly sized hose clamps to prevent air leaks.
- 7** Make sure the air-intake tubing and exhaust piping have no leaks and are not touching each other.

- 8 Protect the air-intake entrance from water and dirt with a guard or shield.
- 9 On a yacht, make sure the thru hull is at least 30" above the waterline and the exhaust must be goose-necked, see *Figure 3-3: The Exhaust Goose Neck Configuration.*

WARNING

This unit is not to be used with an air filter. The use of an air filter can restrict the combustion air and result in improper and unsafe operation.

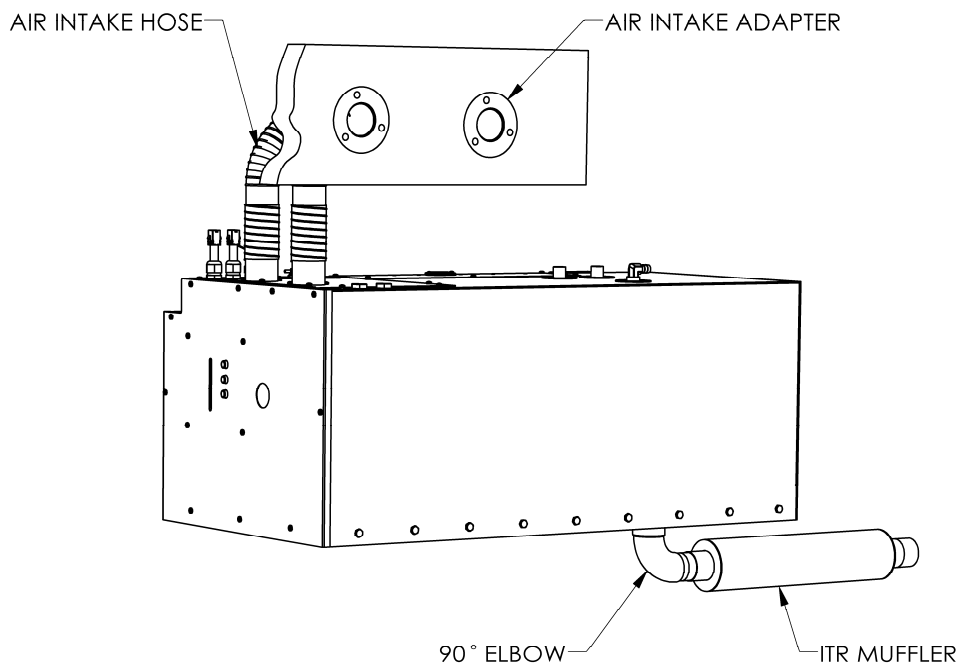

Figure 3-1: Installing the Exhaust System (Bottom Exhaust)

Section 3, Installing the Exhaust System

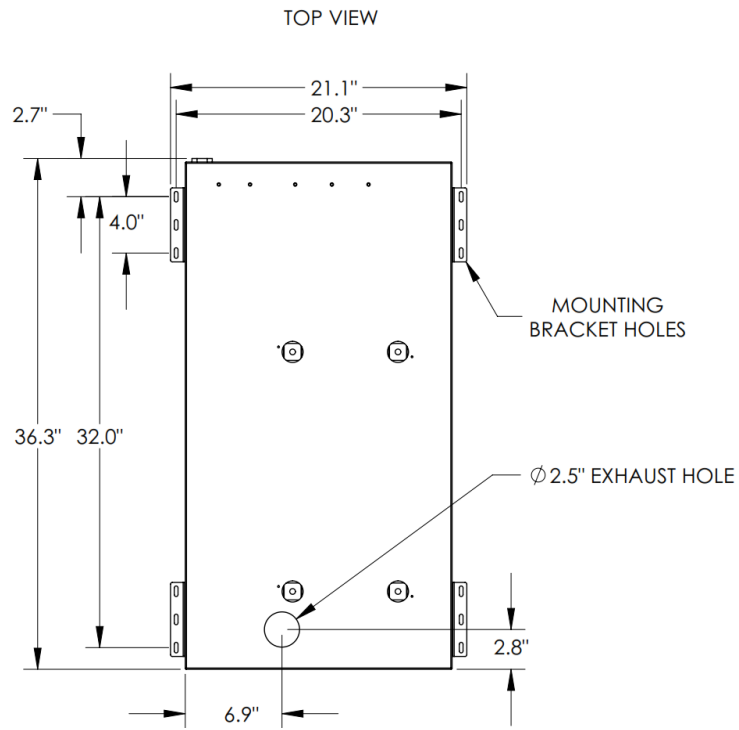

Figure 3-2: The Exhaust Hole Location & Mounting Template

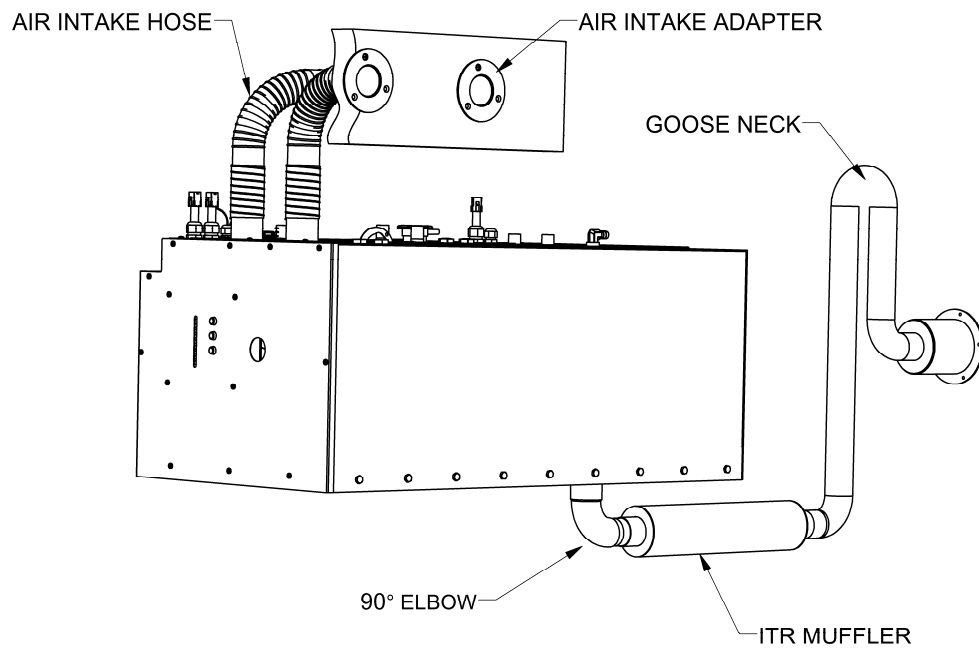
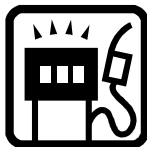

Figure 3-3: The Exhaust Goose Neck configuration

Installing the Fuel System



4.1 Before You Begin

For efficient and safe operation of the Oasis[®] NE-S Heating System, follow all recommendations for properly installing the fuel system. Any deviations from these must be approved in advance by ITR.

! DANGER

Use only diesel #1 and #2 in the Oasis[®] NE-S Heating System. DO NOT USE GASOLINE, CRANKCASE OIL, OR ANY OIL CONTAINING GASOLINE.

Keep fuel lines away from any heat source above 100°F (38°C).

Keep gasoline and any equipment that uses gasoline away from the Oasis[®] NE-S Heating System location. The Oasis[®] NE-S Heating System is not rated for use in an explosive environment.

! WARNING

Never share the fuel supply to the Oasis[®] NE-S Heating System with any other fuel-burning device.

4.2 Fuel System Installation

The fuel pump in the Oasis[®] NE-S Heating System has a maximum flow capacity of 32 GAL/Hr and a maximum pressure of 11.5 psi. A 10 micron fuel filter is recommended. Select a fuel filter based on these requirements.



Recommendations for Installation

The Oasis[®] NE-S Heating System's fuel connections are accessed from the top of the heater. The fuel inlet/outlet connections are located on the top right of the Oasis[®] NE-S Heating System and consist of 1/8" NPT threaded female fittings. The minimum recommended size for the fuel line is 1/4" I.D. The fuel return line should return directly to the fuel supply tank.

The following is recommended for the fuel system installation:

NOTICE

The fuel supply from the fuel storage tank to the fuel inlet must be from a dedicated fuel pickup on the top of the tank.

- The fuel supply line should be installed with minimal rise from the fuel tank. The total rise from the bottom of the pickup tube to the fuel inlet on the Oasis® NE-S should not exceed 60". There are no minimum clearance requirements between the fuel tank and the Oasis® NE-S.

! CAUTION

The fuel line must be routed and secured to prevent damage, chafing and kinking during normal operation.

- All fuel line connection points and hoses must use suitable clamps and/or sealant and must be checked for leaks on the initial installation and also periodically as part of normal maintenance.
- A primary, UL and/or CSA approved fuel oil filter (not provided) must be installed inline on the fuel supply hose, between the tank and the Oasis® NE-S, in a manner that ensures easy access for maintenance. A secondary fuel filter is mounted inside the Oasis® NE-S, just behind the fuel nozzle. Both filters must be inspected and replaced as required as part of normal maintenance.
- Fuel line hose used must be appropriate for your requirements. It is strongly recommended that the hoses have permanently installed end fittings.



4.3 What NOT to Do

- **Don't** allow the fuel or the fuel lines to become contaminated with foreign material.
- **Don't** allow the fuel lines to become damaged or constricted.

! CAUTION

Ensure that fuel lines are always protected from contamination by foreign material. When installing or servicing, seal off ends to prevent contamination. After installing, you may also wish to flush the fuel line to rid of it air and any foreign material.



4.4 Procedure

To complete the fuel system installation:

- 1** Install an inline fuel filter. The optimal location is on a compartment wall next to the Oasis[®] NE-S, inline between the fuel tank and the Oasis[®] NE-S.
- 2** Connect the fuel line to the dedicated fitting on the main diesel fuel tank.
- 3** Inspect the supply fuel line for any loose connections or damage. Fittings must be airtight.
- 4** If desired, install a shut-off valve on the tank side of the fuel filter to allow shutdown and filter service.

Installing Fan Heaters



5.1 Before You Begin

ITR makes a variety of 12 VDC fan heaters for individual cabins or areas:

The Small Space Cabin Fan (6095) draws 0.5 Amps and has an output of 4000 BTU/h.

The Low Profile Cabin Fan (6094) draws 1 Amp and has an output of 6000 BTU/h.

The Standard Cabin Fan (6002) draws 0.9 Amps and has an output of 8700 BTU/h.

The High Output Cabin Fan (6093) draws 1.6 Amps and has an output of 12000 BTU/h.

The Defrost Heater draws 10 Amps and provides 20,000 BTU/h. It comes with a 3-speed switch to control the speed of the fan.

For best results, the fans should be mounted as close to the floor as possible. They have a built-in aquastat (optional), which turns on the fan when the coolant running through it reaches 120°F (49°C).

Note: A limited number of fan heaters can be used with the Oasis[®] NE-S Heating System.

NOTICE

Only the installation of ITR fan heaters is covered in this Manual.

If you are installing non-ITR fan heaters, you must obtain prior approval from ITR. You must check the fans' total amperage draw to ensure they will be compatible with the Zone Control Board, as well as flow capacity to ensure that each fan meets system requirements.

5.2 Fan System Operation

ITR fans consist of a 12 VDC brushless fan and heater coil similar to a radiator.

When the heater unit comes on, the fan draws ambient air from the interior, blows it through the heater coil and back into the interior through a vent. There must be an input and output vent for each fan unit.

Features

- The Zone Control Board will not run the fans unless the coolant inside the Oasis[®] NE-S tank is above 120F. However, during the initial startup, the coolant in the lines will be lower than 120F until it has had a chance to mix with the coolant in the tank. ITR heater fans can be supplied with a built-in aquastat, which prevents fan operation until the system has reached minimum operating temperature. *Figure 5-1* shows how to wire up the aquastat in a fan.

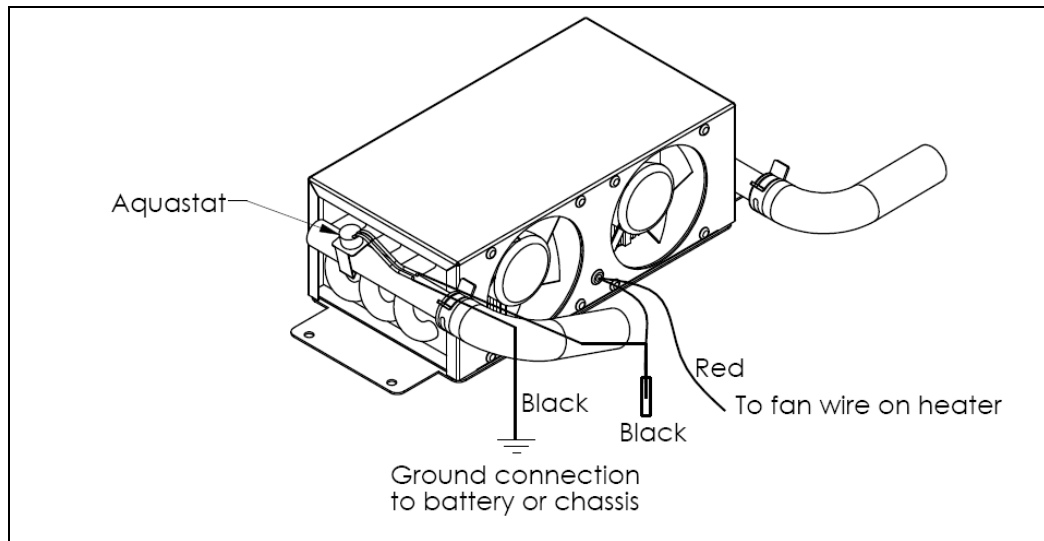

Figure 5-1: Wiring the Fan's Aquastat

- If a "passive" radiant heat system is desired (i.e. baseboard or fin and tube configurations), consult ITR for recommended installation procedures and design.

Multiple Zone Heating

The Oasis[®] NE-S Heating System can supply heat up to five interior zones.

Up to five thermostats (positive DC compatible) can be installed to allow temperature regulation of the zones. The thermostat controls the fan heater.

For larger installations, consult ITR.

Accessories and Components Needed

In addition to the fans themselves, you will need at least some of the following optional accessories and equipment which are not supplied but which can be purchased separately.

- **Thermostats** — thermostats can be installed in the interior. Digital or analog versions are available.
- **Air Outlet Vents** — covers that are installed flush with the wall to vent heat for the installed heater unit.
- **Fan Guards** — to protect the fan blades from damage, recommended for fans installed in storage areas or other accessible areas where something could contact the fan blades.
- **Screws** — #10 sheet metal screws or wood screws to mount the fan units. See *Figure 5-2: Mounting a Spacesaver Fan*.
- **Two-Speed Fan Switches** — to enable low and high-speed settings from inside the coach or yacht; for use with the ITR Cabin heater and Spacesaver fan.
- **Three-Speed Fan Switches** — to enable low, medium and high-speed settings from inside the coach or yacht; for use with the ITR defrost heater.
- **Air Ducting** — to allow you to install fans in a remote location (i.e. not directly adjacent to the interior space to be heated) and duct the heated air to its output location. Also, **air outlet plates** to allow you to install ducting for one, two or three separate outlets (e.g. you can use one fan to heat two different areas by installing a dual air outlet plate).



5.3 What NOT to Do

- **Don't** install more fans that require more heat than the Oasis® NE-S can produce. Your system will not run effectively. If you choose to use fans that draw higher current (more than 10 amps on zone 1, or more than 5 amps on zones 2-5), install a relay to handle the extra load; see *Figure 5-3: Installing a Relay for Additional Fan Amperage*. See section 6.4 for information on the Zone Control Board.
- **Don't** mount the return air outlet too close to the fan's air intake source.



5.4 Mounting Locations

Carefully choose the mounting locations of your fans:

- Locate the fans to evenly heat the specific zone.
- Provision must be made to protect potable water lines from freezing.
- Install fan at floor level or very near floor level, in order to optimize circulation.
- Allow a minimum 16 square inch (100 cm sq.) opening in the fan heaters' mounting compartment to allow sufficient intake of air.

ITR can suggest optimal fan locations if you provide a floor plan of your coach or yacht.



ITR's Cabin Fans (Low Profile Cabin Fan pictured at left) are attached to a mounting plate. They are designed to mount horizontally on a flat surface.



The thermostat should not be mounted on walls outside of the zone because that could cause false temperature readings. Mount on interior walls and bulkheads, away from windows, heater vents and cabin fan heaters.



5.5 Procedure

After choosing the appropriate mounting location and configuration:

- 1** Mount the fan using #10 sheet metal screws or wood screws, see *Figure 5-2: Mounting a Low Profile Cabin Fan*.
- 2** If you are using ducting and a dual air outlet plate for any fan, limit the total length of duct for both outlets to 36" for optimum air output.
- 3** Select the appropriate mounting location for the thermostat, as well as any fan speed switches. You will wire these up to the Zone Control Board in *Section 6 – Wiring The Electrical System*.
- 4** The Zone Control Board can control up to 5 zones. The cabin fan 1 lead (orange) can supply up to a maximum of 10 Amps. The other cabin fan leads 2-5 can supply up to a maximum of 5 Amps each. The total current draw is not to exceed 18 Amps for all cabin fan leads.
- 5** If the system requires higher amperage draws, install a separate relay to power the fans. This relay will use the existing fan circuit as a signal and must be wired to a secondary power source (not the heater's control board). See *Figure 5-3: Installing a Relay for Additional Fan Amperage*.
- 6** To install plumbing lines to the fans, see *Section 7 – Plumbing the System*.

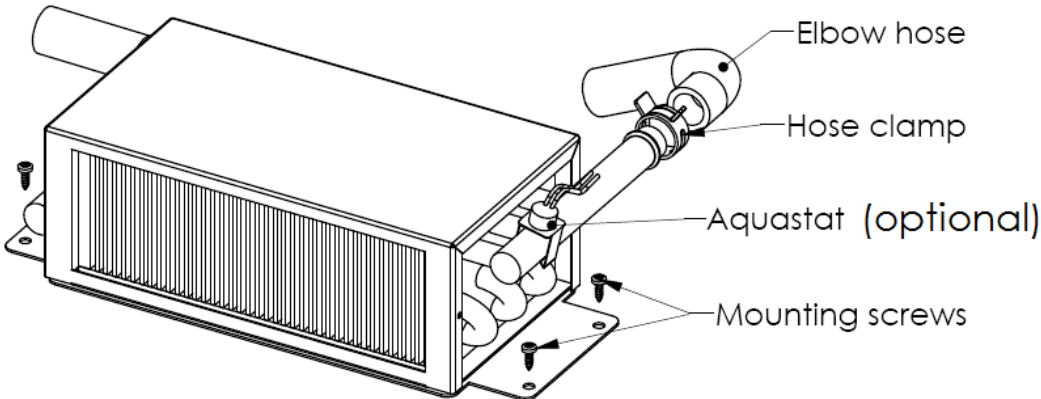

Figure 5-2: Mounting a Low Profile Cabin Fan

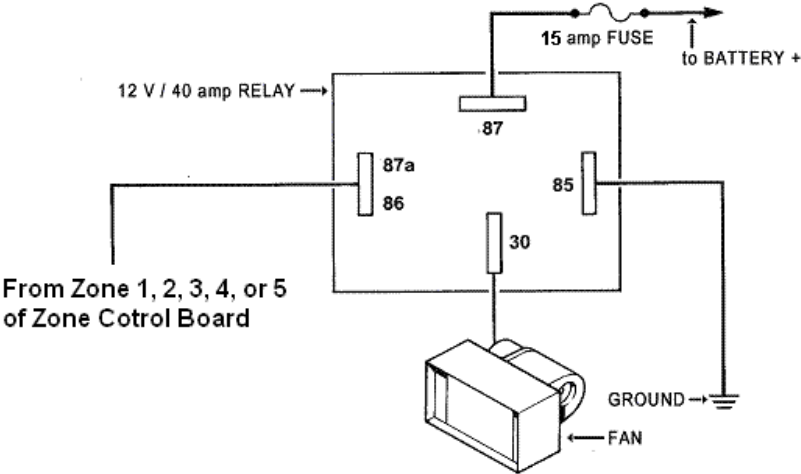

Figure 5-3: Installing a Relay for Additional Fan Amperage

Wiring the Electrical System



6.1 Before You Begin

The Oasis[®] NE-S and its electrical Control Board (mounted internally) are pre-wired and have been thoroughly tested together as a unit. To integrate the Oasis[®] NE-S into your system, wiring will be required between the following system components:

- 120VAC Power
- 12VDC battery
- Oasis[®] NE-S Heater
- Oasis NE-S Remote Operating Panel
- Oasis NE-S Zone Control Board
- Thermostats
- Cabin Fans

To review the wiring for the Oasis[®] NE-S Heating System, refer to the wiring diagram shown in *Figure 6-1: System Wiring*.

! WARNING

All electrical connections and wiring must comply with normally-accepted 12 VDC and 120 VAC wiring practices, local regulations, and ABYC/RVIA standards. Only a qualified electrical installer should complete the wiring. All field wiring is to be in accordance with CSA Standard C22.1, Canadian Electrical Code Part I or the National Electrical Code, ANSI/NFPA 70.

NOTICE

The main electronic Control Board is mounted onboard the Oasis[®] NE-S itself. It has no user adjustable components.

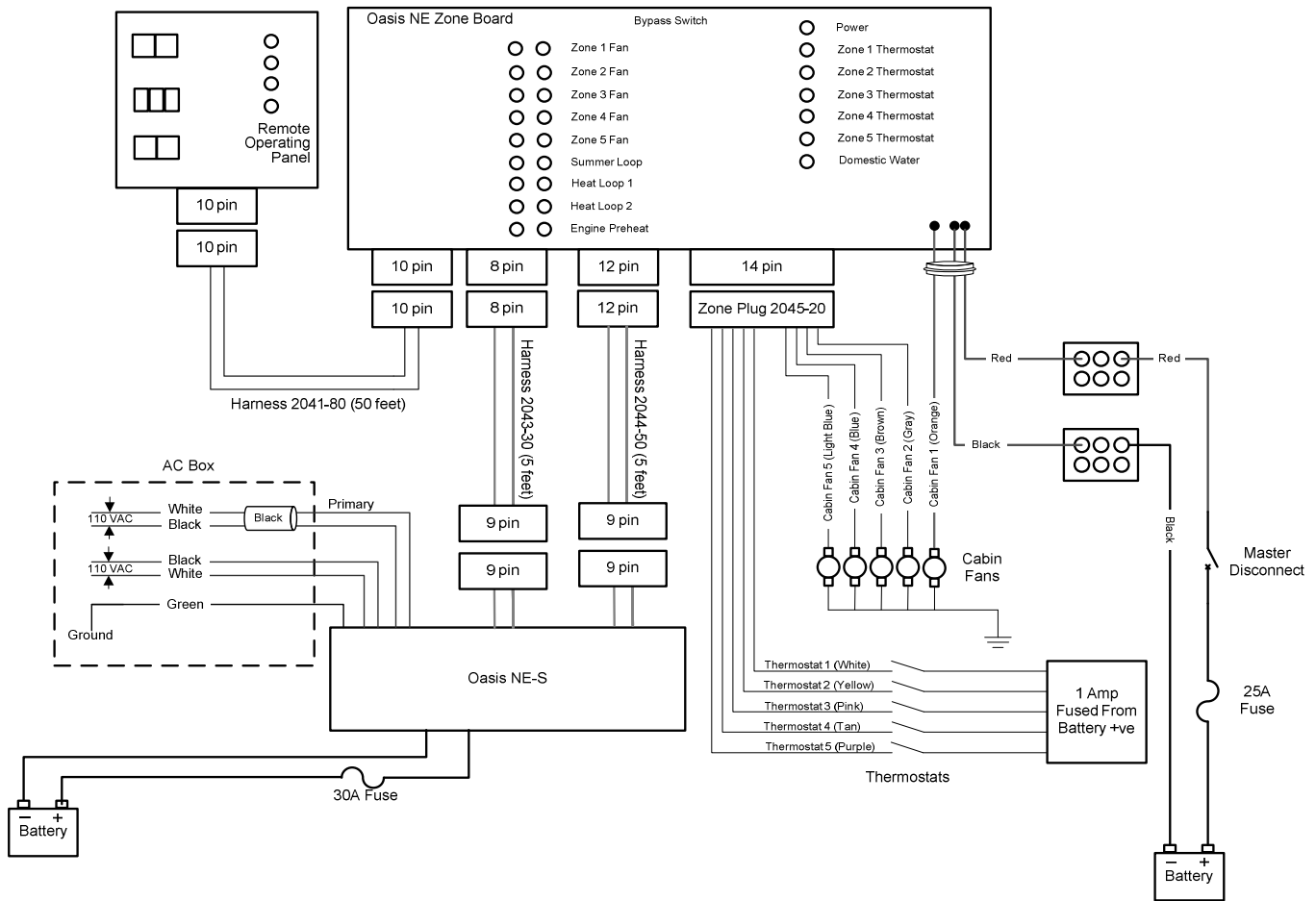

Figure 6-1: System Wiring

6.2 Oasis® NE-S 12 VDC

The following apply to the 12 VDC connections of the Oasis® NE-S:

- There is one paired set of 12 VDC electrical connections on the top left of the Oasis® NE-S. They consist of the primary DC positive (red) and negative (black) connection and are 12 gauge stranded copper wires.

! WARNING

Primary DC power should originate from a dedicated connection on the house battery bank. A 30 amp fuse must be included close to and inline from the battery to the positive (red) connection on the Oasis[®] NE-S Heating System. The primary power wire gauge must be sized to permit no more than a 3% voltage drop from the battery to the Oasis[®] NE-S Heating System.

- The 12 VDC connections to the Oasis[®] NE-S must be connected directly to the battery (through a fuse). There should be no battery disconnect switch between the battery and the Oasis[®] NE-S. This is to prevent the burner from being shut down without first going through its appropriate purge period. Without a proper purge period to cool the combustion chamber, the internal components of the Oasis[®] NE-S will become damaged. Note that the power to the Zone Control Board (see section 6.5) can go through a battery disconnect switch.
- A properly-shielded power system is required for safe, trouble-free operation.

6.3 Oasis[®] NE-S 120 VAC

- The Oasis[®] NE-S Heating System is equipped with two 1500 watt, 120 VAC (60 Hz) immersion elements. The connections for the electrical supply are on the top left side of the Oasis[®] NE-S Heating System, under a cover, labeled AC power.
- The power wires for the AC immersion elements are 14 gauge stranded copper leads that use standard AC color code (black-hot, white-neutral, green-ground). These are to be connected using standard 120 VAC electrical connectors and terminals.
- There are two sets of AC power wires, one set with black heat shrink (primary) and one set without heat shrink (secondary). Each individual set must be connected to a separate AC circuit breaker. The primary set of wires is connected to the left AC element, and the secondary set of wires is connected to the right AC element, located inside the Oasis[®] NE-S Heating System. If only one AC circuit breaker is available, you must connect to the primary wire set only. Once the connections are completed, the wires are to be inserted back into their compartment and the cover secured.
- The ground wire (green) is shared between the two connections.

6.4 Wiring the Zone Control Board

- Primary 12 VDC power to the Zone Control Board should originate after the master disconnect switch from a dedicated connection on the house battery bank.
- A 25 amp fuse or breaker must be included inline from the power source to the positive connection on the Zone Control Board. The primary power wire gauge must be sized to permit no more than a 3% voltage drop from the power supply to the Zone Control Board.
- The Oasis[®] NE-S and the Remote Operating Panel are connected to the Zone Control Board through the electrical connections located at the bottom of the Zone Control Board.
- The Zone Control Board connects to the thermostats and cabin fans through a 14 pin plug, with butt connect leads.

Cabin Fan leads

- The positive (red) lead from each cabin fan is to be attached to one of the trailing cabin fan leads, color coded for zones, from the thermostat and cabin fan connector plug.
- The negative lead from each cabin fan is to be attached to a ground terminal (not provided) that is connected to a battery ground.
- The cabin fan 1 leads (orange) can supply up to a maximum of 10 Amps. The other cabin fan leads 2-5 can supply up to a maximum of 5 Amps each. The total current draw is not to exceed 18 Amps for all cabin fan leads.
- If the system requires higher amperage draws, install a separate relay to power the fans. This relay will use the existing fan circuit as a signal and must be wired to a secondary power source (not the heater's control board). See Figure 5-3.

Thermostat Leads

- The power lead to the thermostat should be fused (1 Amp) and attached to a power terminal (not provided) that is connected to the battery.
- The return lead from each thermostat is to be attached to one of the trailing thermostat leads, color coded for zones, from the thermostat and cabin fan 14 pin connector plug on the zone control board.
- Note that the zone control board uses Heating Loop 1 to supply coolant to Zones 1 and 2, and uses Heating Loop 2 to supply coolant to Zones 3, 4, and 5. Zones 1 and 2 are calling for heat, the zone control board will activate the Heat Loop 1 pump. When Zones 3, 4, and 5 are calling for heat, the zone control board will activate the Heat Loop 2 pump.



6.5 What NOT to Do

NOTICE

Never shut off the Oasis[®] NE-S Heating System power via an inline battery or master switch while the system is running. Never disconnect the battery when the Oasis[®] NE-S Heating System is running, and never disconnect the battery while the inverter is charging. Do not wire the Oasis[®] NE-S Heating System through a disconnect that is used as a normal shut-down of the DC system.

Doing either will severely damage the Oasis[®] NE-S Heating System because it fails to automatically purge the combustion chamber. Such damage is detectable upon inspection and will *not* be covered under warranty. Always shut the system off using the normal system controls, after it has completed its purge and cooled down the combustion chamber.

Plumbing the System

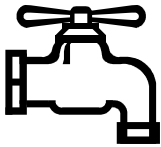

7.1 Before You Begin

For efficient and safe operation of the Oasis[®] NE-S Heating System, follow all of the recommendations in this section for properly installing the plumbing system. Any deviations from these must be approved in advance by ITR.

! DANGER

The Oasis[®] NE-S Heating System must use a non-toxic, propylene glycol based coolant with additives generally recognized as safe "GRAS" by the FDA. Use of non-propylene glycol based coolant can be harmful if contamination of potable water occurs due to a leak in the heat exchanger, which could be caused if the fresh water in the system is allowed to freeze.

When heat is called for, the distribution pumps in the NE-S send heated fluid out to the cabin fans and potable water heat exchanger.

For an efficient Oasis[®] NE-S Heating System operation, you must:

- Minimize heat loss from the Oasis[®] NE-S and hoses.
- Balance the heat output for each of the zones and balance the heat drawn by both space heating loops. Balancing can be done by adjusting the number and size of the cabin fans installed in each loop in the Oasis[®] NE-S Heating System. Figure 7-2: *Plumbing Oasis[®] NE-S Heating System for Five Zones*, shows a typical plumbing layout for circulating coolant from the Oasis[®] NE-S to the cabin fans in the two loops, and back to the Oasis[®] NE-S.

7.2 Coolant Plumbing Installation

The plumbing installation should consider the following:

- The Oasis[®] NE-S has an overflow fitting located on the top of the unit. Ensure a four (4) quart minimum overflow bottle is attached to the overflow fitting. The connection point should be from the bottom of the overflow bottle.
- The supply and return coolant plumbing connections are on the top of the Oasis[®] NE-S Heating System. The supply fittings are 1/2" NPT (female) bulkhead fittings, and the return fittings are 1/2" NPT (male) fittings. The supply coolant outputs from the Oasis[®] NE-S are labeled "Heating Loop 1 Supply" and "Heating Loop 2 Supply". The return coolant inputs to the Oasis[®] NE-S are connections labeled "Heating Loop 1 Return" and "Heating Loop 2 Return". Ensure proper direction of flow. Refer to Figure 7-1: *Oasis[®] NE-S Overview* for the location of the fittings.
- Two 1/2" NPT to 3/4" hose barb fittings must be fitted into the Oasis[®] NE-S coolant supply connections. Two 1/2" FPT to 3/4" hose barb fittings must be fitted into the Oasis[®] NE-S coolant return connections. All connections must be tightened to a leak free condition using an appropriate thread sealant.
- Hose and/or tubing used to connect to the Oasis[®] NE-S supply and return connections must be heavy duty heater hose, minimum 3/4" I.D, or 5/8" PEX.

NOTICE

All fittings (except Heat Loop 1 & 2 return fittings) on the Oasis[®] NE require two wrenches when tightening. One wrench must be placed on the bulkhead fitting and held in place to prevent this fitting from being overstressed. The other wrench can be used to tighten the matching half of the fitting onto it. Failure to follow this procedure will damage the Oasis[®] NE-S and the fittings.

! DANGER

Do not operate the Oasis[®] NE-S Heating System until a proper water/anti-freeze solution has been added to the Oasis[®] NE-S and the heating system and all trapped air has been bled. An inadequate mixture may cause system circulation problems and potential Oasis[®] NE-S Heating System damage and/or personal injury. Use only a non-toxic, propylene glycol based coolant with additives recognized as safe "GRAS" by the FDA. Refer to the anti-freeze manufacturer recommendations for instructions for your application.

Section 7, Plumbing the System

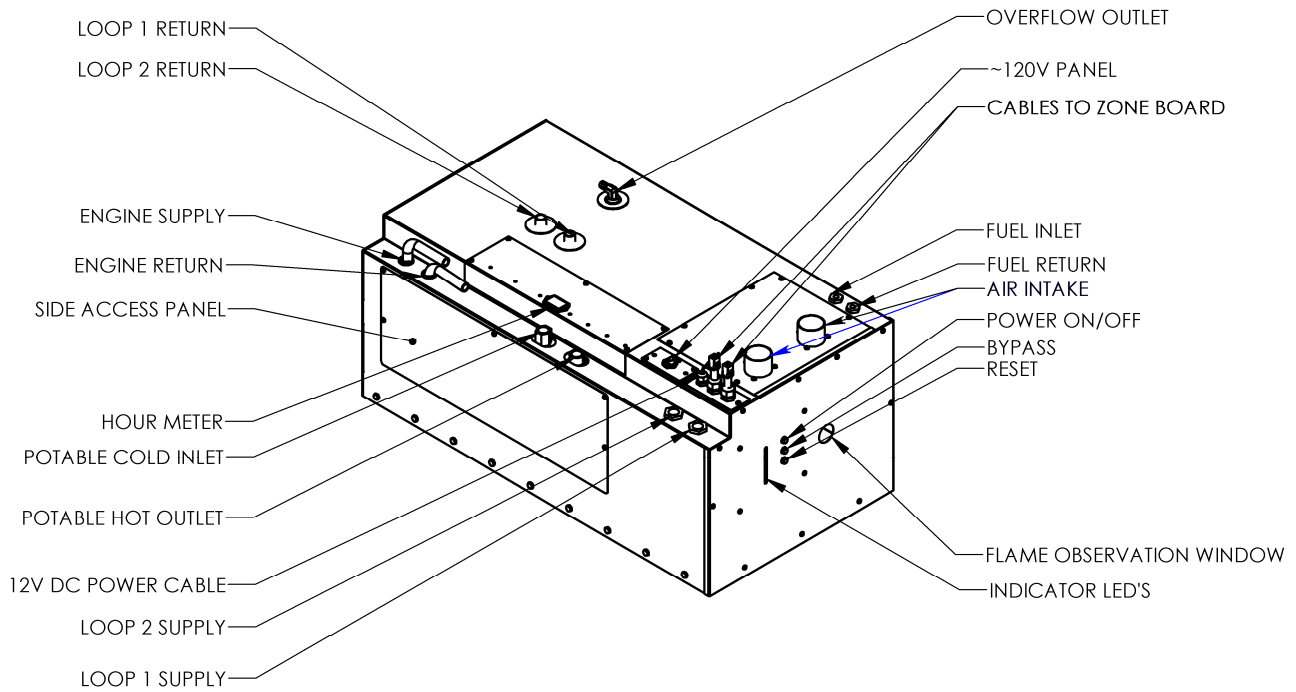

Figure 7-1 Oasis® NE-S Heating System Overview

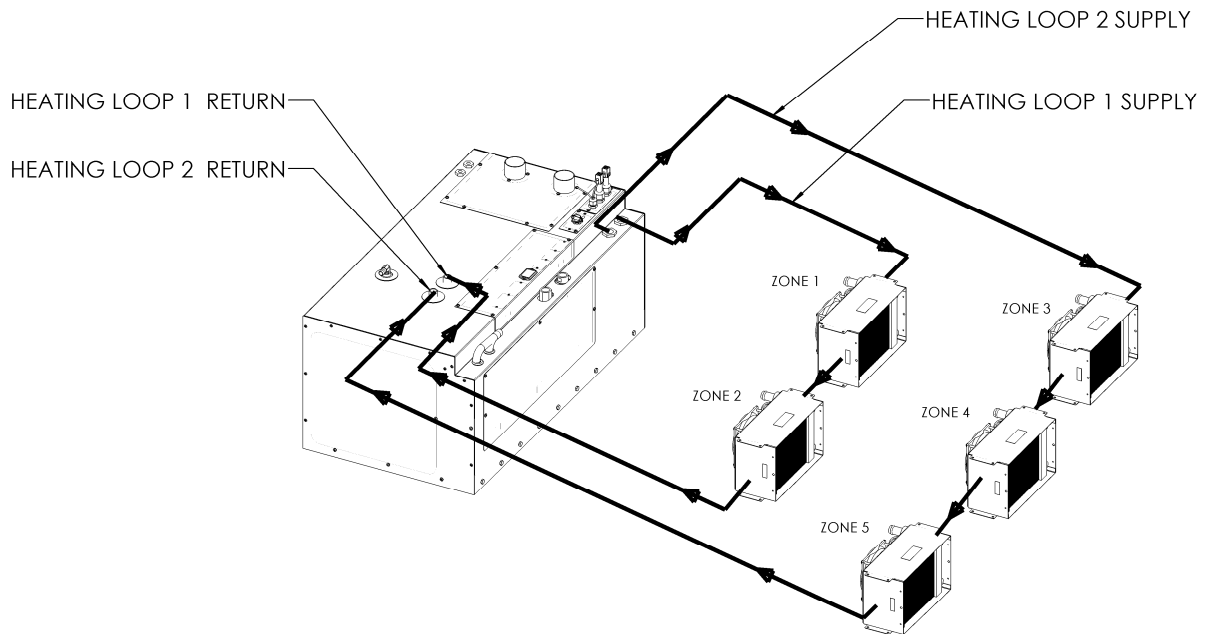

Figure 7-2: Plumbing Oasis® NE-S for 5 Zones

- All plumbing lines must be routed and secured to prevent damage, chafing and kinking.
- Ensure that the coolant flow is adequate through the Oasis[®] NE-S Heating System. The flow rate through each of the space heating loops should be at least 2.5 GPM. An indication of inadequate flow is a large temperature difference between the first cabin fan and the last cabin fan in each space heating loop (when the Oasis[®] NE-S Heating System is running and up to normal operating temperature). In a properly flowing system, each fan in the space heating loop will have an outlet temperature that is only a few degrees cooler than the preceding fan.
- The Oasis[®] NE-S should be filled and flushed prior to operation to remove any foreign debris.
- Use heavy-duty heater hose or PEX tubing. Slip-on foam insulation coverings may be used over the hose fittings to reduce heat loss. Secure all hose connections with constant tension spring clamps.



NOTICE

7.3 What NOT to Do

The Oasis[®] NE-S Heating System's coolant distribution pumps are one of the most critical parts of the system. **Never** let the pumps run dry or damage will occur to the impellers. This is not covered under warranty.

Don't use low-quality heater hose.

Don't let the hose come into contact with solvents, which may cause it to soften and swell. If there is any risk that solvents may contact the hose, insert it into PVC plastic tubing for protection.



7.4 Coolant Plumbing Installation Procedure

To install and connect the Oasis[®] NE-S and heater hose:

- 1 Connect two 1/2" NPT to 3/4" hose barb fittings onto the Oasis[®] NE-S coolant supply connections. Connect two 1/2" FPT to 3/4" hose barb fittings onto the Oasis[®] NE-S coolant return connections. Tighten all connections to a leak free condition using an appropriate thread sealant.
- 2 Hose and/or tubing used to connect to the Oasis[®] NE-S supply and return connections must be heavy duty heater hose, minimum 3/4" I.D, or 5/8" PEX.

Install the cabin fans for both space heating loops by connecting the supply line to the lower port on the cabin fan and the outlet to the next fan in the series loop. Each cabin fan heater should be plumbed so that fluid supply enters the bottom of the heating core and exits from the top. This helps keep air from being trapped in the cabin fan core. Ensure proper direction of flow. Refer to Figure 7-1: *Oasis[®] NE-S Overview* for the location of the fittings. Ensure there are no kinks or sharp bends that might restrict the fluid flow. See Figure 7-3: *Three Approved Methods of Installing Heater Hose (Consult ITR for Alternative Methods and Products)* for methods of attaching the heater hose.

- 3 Once the two space heating loops have been set up with the cabin fans, connect the two individual space heating loop supply lines to the "Heating Loop 1 Supply" and "Heating Loop 2 Supply" connections on the Oasis[®] NE-S. Connect the two space heating return lines to the "Heating Loop 1 Return" and "Heating Loop 2 Return" connections. Note that the zone control board uses Heating Loop 1 to supply coolant to Zones 1 and 2, and uses Heating Loop 2 to supply coolant to Zones 3, 4, and 5.
- 4 The Oasis[®] NE-S has an overflow fitting located on the top of the unit. Ensure a four (4) quart minimum overflow bottle is attached to the overflow fitting. The connection point should be from the bottom of the overflow bottle.

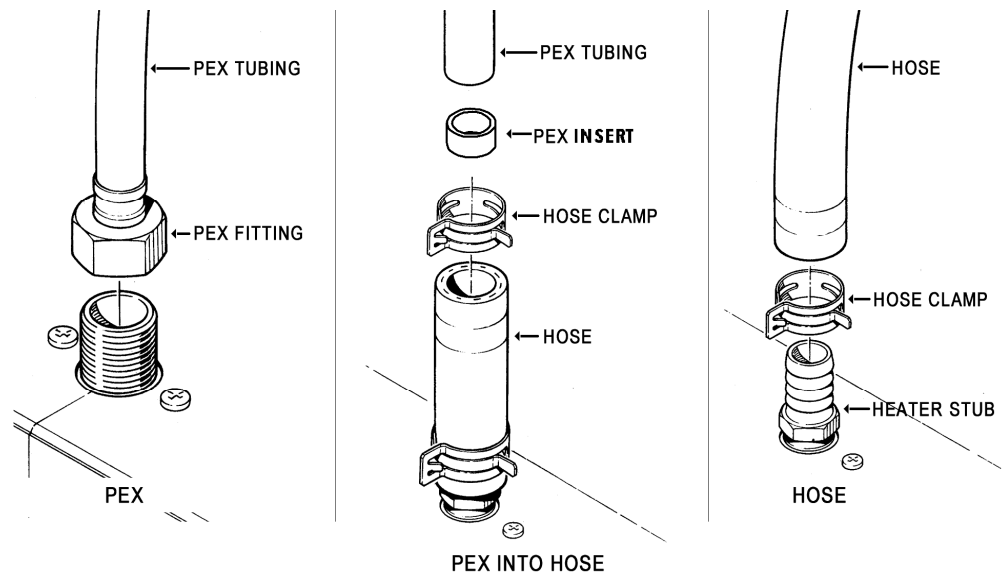

Figure 7-3: Three Approved Methods of Installing Heater Hose (consult ITR for alternative methods and products)

7.5 Potable Water Plumbing Installation

The Potable water connections are located on top of the Oasis[®] NE-S. The Cold water supply and Hot water outlet can be connected using ½" NPT to PEX crimp fittings.

The maximum water supply pressure to the heater is 150 PSI (10 bar). The Hot water Outlet temperature is regulated by an internal mixing valve factory set at 120F (49°C). If needed this valve can be adjusted between a range of 95F (35°C) to a maximum of 145F (63°C). A potable water drain is provided for winterizing purposes. This will prevent damage to the internal heat exchanger due to freezing water. See *Figure 7-4: Potable Hot water system plumbing*.

WARNING

All fittings, hose, tube and fitting sealant involving the potable water must be food safe and approved for use with potable water and rated for the potable water system pressure.

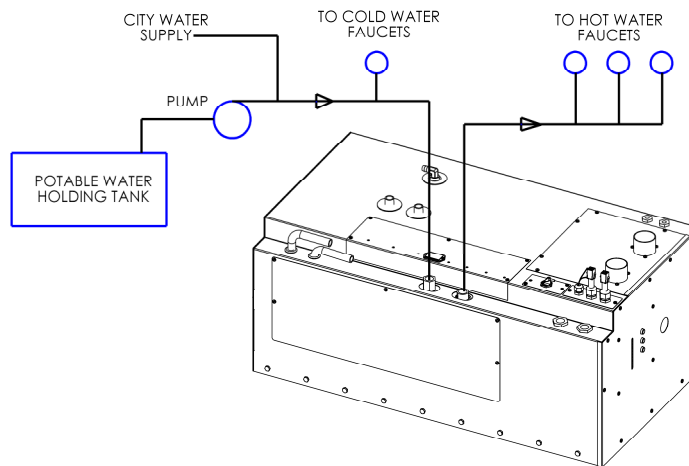

Figure 7-4 Potable Hot Water System Plumbing

7.6 Engine Plumbing Installation

The Engine Heat Inlet/Outlet connections are located on top left (towards the back) of Oasis[®] NE-S. These connection points are 1/2" hose. The connection can be made by placing PEX inserts into the 1/2" PEX hose, and sliding 1/2" PEX into the hose and clamping it in place. Alternatively, a 1/2" barb to 1/2" or 3/4" barb fitting can be used to make the connection to the engine coolant hose.

Hot coolant from the engine enters the Oasis[®] NE-S at the "Engine Heat Inlet". The "Engine Heat Outlet" returns the coolant back to the engine supply. This makes use of engine waste heat.

If the pre-heat function is installed, an additional pump is installed (inside the Oasis[®] NE-S) to move the engine coolant through the engine heat exchanger, when the engine is turned OFF. The pre-heat switch on the Remote Operating Panel will activate this pump. See *Figure 7-5: Engine heat/pre-heat system plumbing*.

It is recommended to contact the vehicle/engine manufacturer prior to proceeding with the engine plumbing installation.

WARNING

Prior to operating the engine pre-heat pump, the engine coolant loop must be connected to the Oasis[®] NE-S and the coolant line purged of air. The power to the engine pre-heat pump is left disconnected at the factory. Once the engine coolant loop has been purged, the side cover of the Oasis[®] NE-S must be removed and the power to the engine pre-heat pump must be connected.

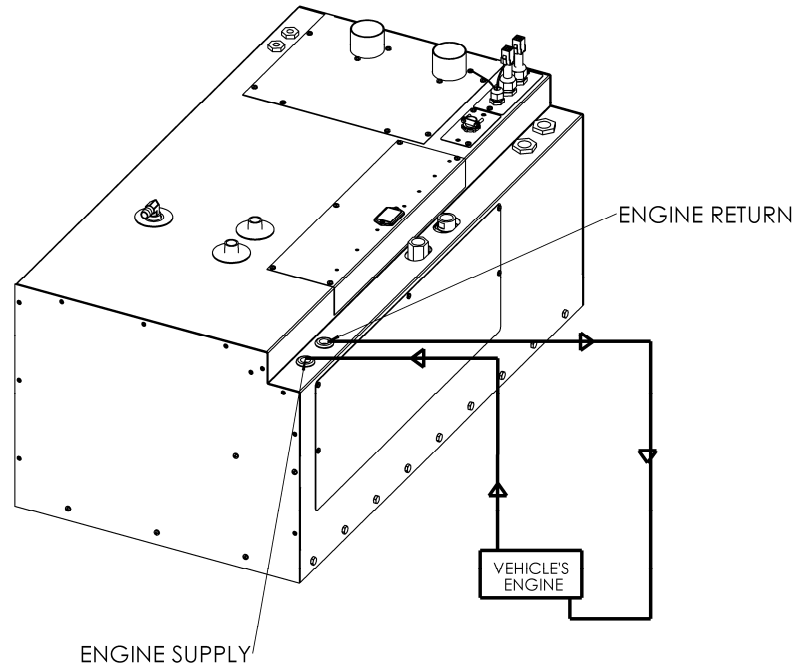

Figure 7-5 Engine Heat / Pre-heat System Plumbing

7.7 Procedure For Filling/Purging The Oasis[®] NE-S Heating System

- 1 Do not operate the Oasis[®] NE-S Heating System until the proper water/anti-freeze solution has been added to the Oasis[®] NE-S Heating System and all trapped air has been bled. An inadequate mixture may cause system circulation problems and potential Oasis[®] NE-S Heating System damage and/or personal injury.

Use only a non-toxic, propylene glycol based coolant with additives recognized as safe "GRAS" by the FDA. Refer to the anti-freeze manufacturer recommendations for instructions for your application.

- 2 Remove the front cover of the Oasis[®] NE-S, and using a self priming pump, fill the Oasis[®] NE-S Heating System through the filler port (1/2" hose barb connection) located at the bottom of the unit with a 50/50 mixture of propylene glycol and water.

Section 7, Plumbing the System

- 3 When the fluid starts to run into the overflow bottle, turn on the Bypass Switch on the Zone Control Board and wait until the coolant lines are filled and the overflow bottle fills to the "Minimum when cool" level.
- 4 When this level is reached, turn OFF the filler pump, and keep the bypass switch turned ON until the system is purged of air and the coolant level in the overflow bottle does not change.
- 5 Once the system has been purged of air, turn OFF the Bypass Switch on the Zone Control Board. This Bypass Switch should remain off during normal operation. It is only used to fill and purge the system. The shut-off valve on the filler hose must be in the closed position when the system has been filled.

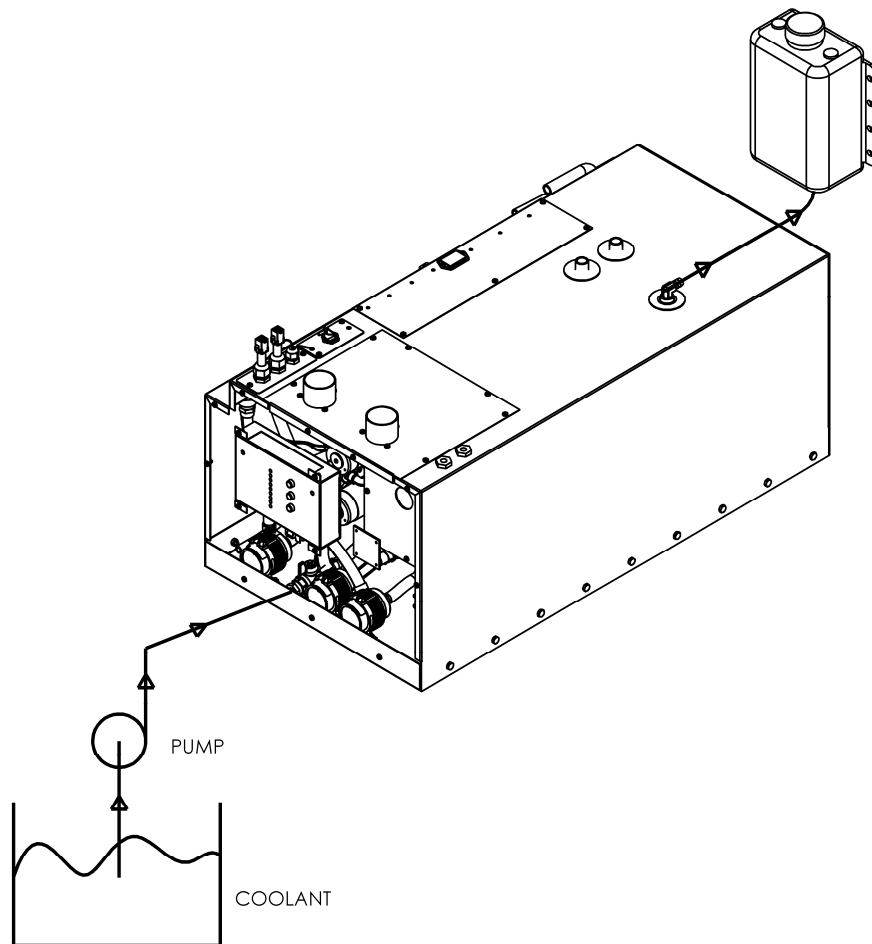

Figure 7-6 Filling/Purging Oasis[®] NE-S Heating System Engine Heat / Pre-heat System Plumbing.

Operating the Oasis[®] NE-S Heating System

This section describes the features, operation and maintenance of your new Oasis[®] NE-S Heating System. READ THESE INSTRUCTIONS AND SAVE FOR REFERENCE.

8.1 Features of Your Oasis[®] NE-S Heating System

The Oasis[®] NE-S Heating System uses an 85,000 BTU (true output) diesel burner controlled by a 12 VDC multi-functional electronic controller as the primary source of heating coolant (anti-freeze and water). Two 1500 Watt, 120 VAC immersion elements are used as secondary heat sources to provide an additional 10,000 BTU of heat. The Oasis[®] NE-S Heating System heats the coolant to provide a source of heat for all hydronic space heating needs. Through the use of its integral distribution pumps, the Oasis[®] NE-S Heating System has the ability to circulate the coolant to all space heating areas. It can also provide a supply of domestic hot water using the integral heat exchanger. The Oasis[®] also incorporates engine heat and preheat functions. (See *Figure 1-2: Oasis[®] NE-S Heating System*).

Other features of the Heating System include:

- Built in coolant distribution pumps capable of supplying coolant to multiple heating fans in two separate loops, located in up to five different zones.
- An internal heat exchanger provides for production of potable hot water.
- A separate internal heat exchanger provides for use of engine waste heat and engine pre-heat (optional). For engine pre-

Section 8, Operating the Oasis® NE-S Heating System

heat, an optional engine pre-heat pump and specific remote panel switch must be installed.

- Support for high flow domestic hot water demand. The system increases ground water temperature by 60F at a flow of 3.0 GPM (using only the diesel burner). The mixing valve (factory pre-set), will limit the temperature to 120F.
- Easy to install and field serviceable with the Oasis® NE-S Heating System hookups and connections easily accessible from the top of the heater.
- Easy to fill and purge, zero pressure system.
- Easy to drain.
- A high-temperature, stainless steel burner and stainless steel jacket.
- 13.75 US gallon welded, insulated stainless steel coolant tank that minimizes heat loss and optimizes heat recovery.
- Domestic water flow switch for quick response to domestic hot water demand.
- Low coolant level switch on the tank.
- Quiet operation and low power consumption.
- Low pressure fuel system with built-in fuel pump.
- Fuel efficient burner capable of burning a wide variety of diesel-based fuels (CSA/UL certified for diesel #1 and #2).
- Exhaust has minimal smoke and smell.
- Fan assisted, sealed combustion chamber is designed to use outside combustion air.
- Simple, low amperage draw ignition.
- Electronically-controlled system with:
 - automatic Safety Shutdown;
 - manual-resettable aquastats for safety overheat protection.
 - LED indicators on the Control Panel for diagnostics.
 - Patented, proprietary flame sensor.

- Remote Operating Panel with ON/OFF switch for the diesel burner, AC elements, and engine pre-heat, if installed.
- Control Panel buttons for Power, Bypass, Reset, and indicator LED's for operational and diagnostic information.

8.2 Operating Instructions for the Oasis® NE-S Heating System

NOTICE

The Oasis® NE-S Heating System must be installed and connections made in accordance with the recommendations in this Installation and Operating Manual prior to operating the heater.

- The Oasis® NE-S Heating System, *Figure 8-1: Oasis® NE-S Heating System*, heats the coolant to a preset temperature and will automatically cycle to maintain the temperature.

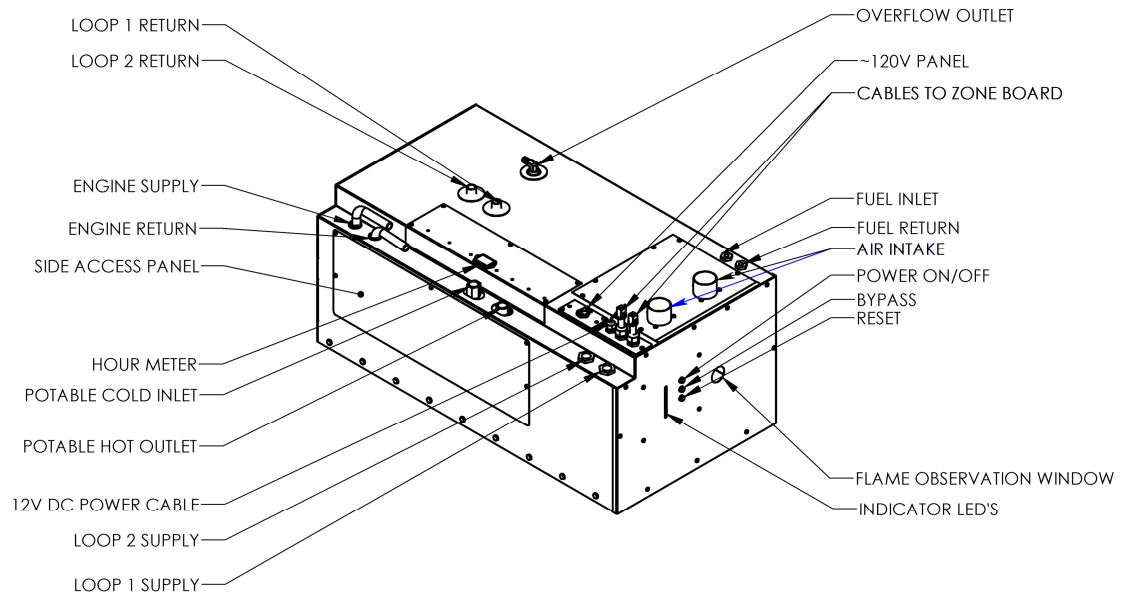

Figure 8-1 Oasis® NE-S Heating System Overview

8.3 Turning the Power to the Oasis® NE-S Heating System ON

- The Oasis® NE-S Heating System's main Control Panel (*Figure 8-2*), located on the front of the heater, contains three push buttons: ON/OFF power, Bypass, and Reset. The power switch must be pushed ON (power LED will turn ON) to turn the DC electrical power to the main control board ON and is required to be left ON whenever heat is required.
- The Zone Control board (*Figure 8-4*) will be powered whenever the master disconnect switch is ON. The master disconnect switch must be left ON whenever heat is required.
- When the Oasis® NE-S Heating System is shut down for any extended period or the season, it is recommended that the power switch and the battery master disconnect switch be turned OFF.

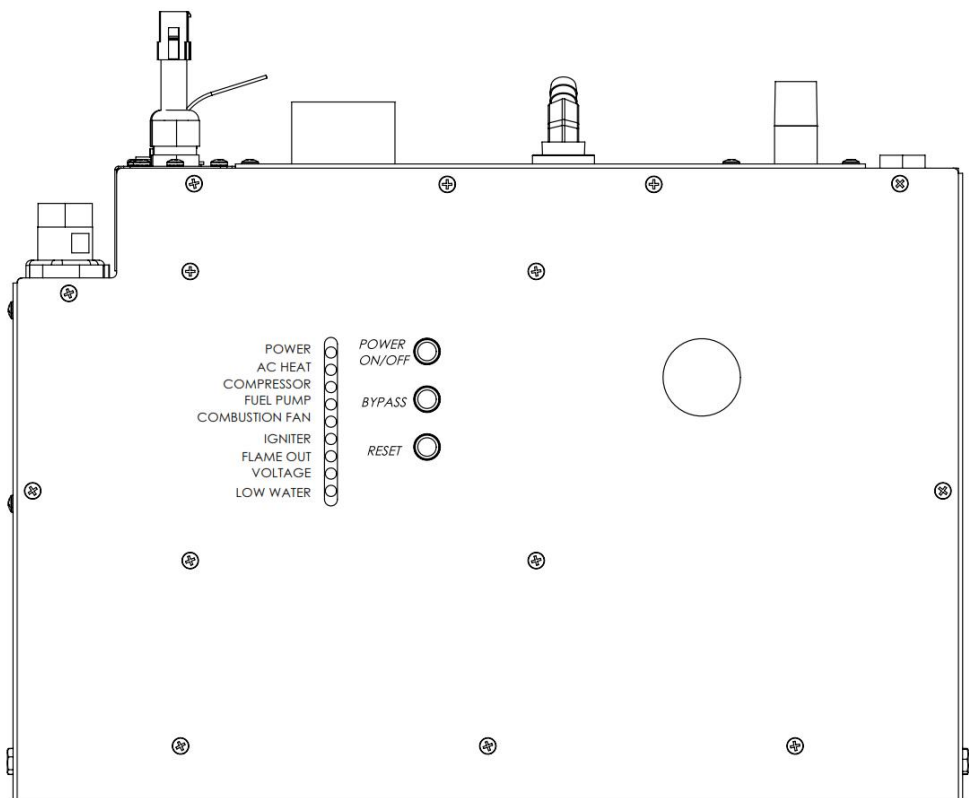

Figure 8-2 Oasis® NE-S Main Control Panel

NOTICE

Do not operate the Oasis® NE-S Heating System until a suitable water/anti-freeze solution is in the heater and all trapped air has been bled or removed.

! DANGER

Use only a non-toxic propylene glycol based coolant with additives generally recognized as safe "GRAS" by the FDA in the Oasis® NE-S Heating System.

8.4 Activating the Burner (Primary) and AC Heat (Supplemental) from the Remote Operating Panel

Activating the Burner (Primary Heat Source)

- The burner switch on the Remote Operating Panel controls the ON/OFF of the diesel burner (primary heat source). When the burner switch is turned ON, the diesel portion of the Oasis® NE-S will turn ON after ten seconds. The Burner LED will turn ON when the diesel burner has been activated. The burner will continue to operate until the coolant in the Oasis® NE-S reaches cycling temperature. At this point, the diesel burner will turn OFF. If the Oasis® NE-S Heating System coolant should cool down below this temperature range, the burner will again commence firing and will continue until either the burner switch on the remote panel is turned OFF or cycling temperature is again achieved. If the burner switch on the remote panel is turned OFF, or cycling temperature is achieved, the burner stops and the Oasis® NE-S enters a two minute cool down stage prior to completely shutting down.

Activating the AC Immersion Element(s) (Supplemental Heat Source)

- Place the AC power switch on the Remote Operating Panel to either the one element or two element position. The AC Heat (green) LED will turn ON indicating the AC element(s) are energized and the coolant is being electrically heated. The elements will continue to operate until the coolant in the Oasis® NE-S reaches cycling temperature. At this point, the elements and the AC heat LED will turn OFF. If the Oasis® NE-S Heating System coolant should cool down below this temperature range, the AC element(s) will again be energized and will continue until either the AC switch on the remote panel is placed in the OFF position or cycling temperature is

again achieved. If the AC element switch on the remote panel is turned OFF, or cycling temperature is achieved, the AC elements are de-energized and the AC Heat (green) LED turns OFF.

Activating the Burner and AC Immersion Element(s) Jointly

- Turn the burner switch ON and place the AC power switch on the Remote Operating Panel to either the one element or two element position. The Burner and AC Heat (green) LED's will turn ON indicating the diesel burner and AC element(s) have been selected.

8.5 Activating the Cabin Fan Heaters through the Thermostats

Burner or AC Heat or Engine Heat Source Available

- Any thermostat connected to the Zone Control Board and calling for heat will cause the cabin fan and loop pump controlled by that thermostat to be enabled (only if the coolant inside the Oasis® NE-S is above 120F). Note that zones 1 and 2 control Loop 1 Pump. Zones 3, 4, and 5 control Loop 2 Pump. Once the room temperature has reached the temperature called for by the thermostat the cabin fan will turn off.

8.6 Activating the Potable Hot Water

Burner or AC Heat or Engine Heat Source Available

- As long as the coolant in the Oasis® NE-S is above 120F, the unit will respond to a call for potable hot water. Ensure that a heat source has been selected (i.e. Burner, AC, Engine). The production of the potable hot water is **continuous** when the burner is operating and **limited** when using AC or engine heat.

NOTICE

The potable water pump is not a part of, nor controlled by the Oasis® NE-S Heating System.

8.7 Potable Water Temperature Adjustment

A thermostatic mixing valve located inside the Oasis® NE-S allows for adjusting the temperature of the potable hot water. The mixing valve is factory set to limit the maximum water temperature to 120°F (49°C) with a total potable hot water demand of 3.0 GPM or less, and an incoming water temperature of 60°F (15°C) or higher. If needed this valve can be adjusted in a range from 95F (35°C) to a maximum of 145F (63°C).

NOTICE

The mixing valve will compensate for temperature variations of incoming supply water and maintain the temperature to which it is set. However, in some cases, the temperature of the incoming water and the flow-rate demand of multiple faucets may limit the ability of the Oasis® NE-S to provide hot water at the temperature setting of the mixing valve, even if the mixing valve is set to its maximum. This is a normal operating characteristic of any on-demand, continuous hot water system that does not rely on heat retained within a stored volume of water. In this situation the temperature of the hot water may be increased by lowering the flow at the faucet and shower head.

To adjust the mixing valve, the side cover of the Oasis® NE-S must be removed. To access the valve, the valve cap must be removed. The mixing valve adjustment knob is shown in Figure 8-2.

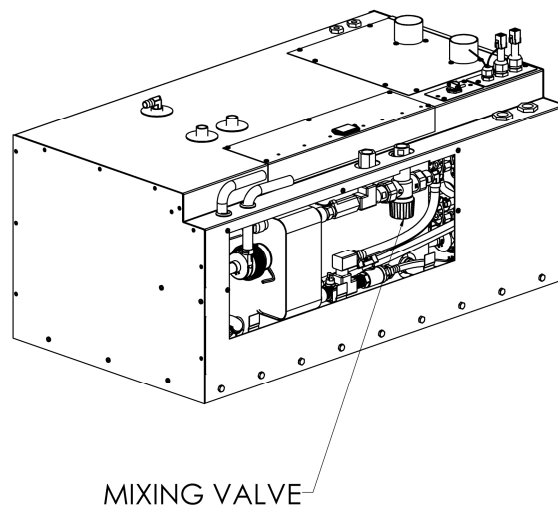

Figure 8-3 Mixing Valve Location

WARNING

The parts inside the heater are **HOT** when in operation. Use gloves when adjusting the mixing valve.

Turning the mixing valve knob clockwise will decrease the hot water outlet temperature and turning the knob counter-clockwise will increase the temperature.

8.8 Activating Engine Heat & Pre-heat

Burner or AC Heat On

Pre-heating the Engine (optional)

- Turn the engine preheat switch on the Remote Operating Panel to the ON position with the burner or AC switch turned ON. The engine preheat pump and coolant distribution pump will be activated once the Oasis® NE-S Heating System is within its set operating temperature range. The engine will start to be preheated by the Oasis® NE-S Heating System.

Engine Heat Used for Potable Water or Space Heating

- Start the vehicle engine and let it come up to the normal operating temperature. Turn the burner switch on the Remote Operating Panel to the ON position. The Oasis® NE-S Heating System will come up to the set operating temperature range and will cycle OFF. The heat from the vehicle engine will be transferred from the engine to the potable water and space heating loops. The burner and/or the AC elements will remain off if enough heat is provided by the engine. If the heat transferred from the engine is not sufficient to meet the space heating and potable hot water demand, the burner and/or the AC elements will turn ON.

8.9 Functions of the Remote Operating Panel

- The Oasis Heating System's Remote Operating Panel, *Figure 8-4: Remote Operating Panel*, contains one ON/OFF burner switch, one triple position AC element switch, one ON/OFF engine heat switch to control the optional engine pre-heat pump, and four LED's indicating Burner activation, AC element activation, heater fault, and zone fault.

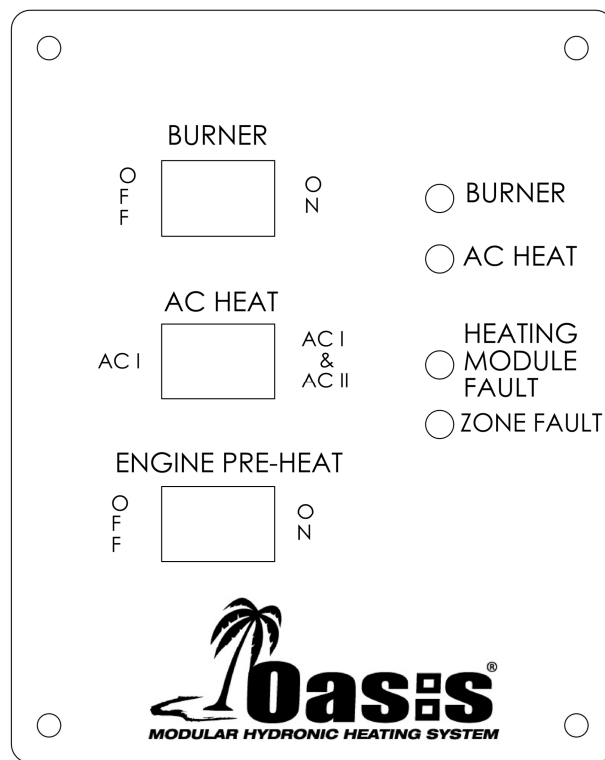

Figure 8-4 Remote Operating Panel

Burner Switch (Primary Heat Source)

- The burner switch on the remote panel controls the ON/OFF of the diesel burner. The Burner LED will turn on when the diesel burner has been activated, and will remain ON while the burner cycles on and off.

AC Element Switch (Supplemental Heat Source)

- The triple position AC element switch controls the activation of a single 120 VAC immersion element only, dual 120 VAC immersion elements jointly, or both elements off. The AC heat LED will turn ON to indicate when the element(s) are operating.

Engine Pre-Heat Switch (optional)

- The engine pre-heat switch (optional) controls the ON/OFF of the engine pre-heat pump (optional). However, the engine pre-heat pump (not included) will not function unless the coolant in the Oasis® NE-S Heating System has achieved a preset temperature.

Burner LED (Green)

- When ON, indicates the diesel burner has been activated.

AC Heat LED (Green)

- When ON, indicates one or both of the 120 VAC immersion elements(s) are operating.

Heating Module Fault LED (Red)

- When ON, indicates the Oasis® NE-S has faulted. The specific fault can be identified by examining the Control Panel located on the front of the Oasis® NE-S. There are indicator LED's on the panel that are used for diagnostics. Refer to the description of the Oasis® NE-S Control Panel (section 8.10) for further details.

Zone Fault LED (Red)

- When ON, indicates a space heating zone(s) has faulted. The specific fault can be identified by examining the Zone Control Board located beside the Oasis® NE-S. There are indicator LED's on the panel that indicate the problem. Refer to the description of the Zone Control Board for further details.

8.10 Functions of the Oasis® NE-S Control Panel

- The Oasis® NE-S Control Panel (Figure 8-2) contains three push buttons: Power ON/OFF, Bypass, and Reset. In addition, it contains nine LED's indicating Power, AC Heat, Compressor, Fuel Pump, Combustion Fan, Igniter, Flame Out, Voltage Fault and Low Water.

Power Button

- The power button turns ON/OFF the power to the control board. The Power LED (green) turns ON when the power to the control board is ON.

Bypass Button

- The bypass button is for **authorized service personnel only**.

Reset Button

- The reset button when pressed resets the control board.

Power LED (Green)

- The power LED (green) turns ON when the power to the control board is ON. The LED flashes when the Oasis® NE-S is in Bypass mode.

AC Heat LED (Green)

- The AC Heat LED (Green) turns ON when 120VAC is connected to the unit and the system has not yet reached the set point operating temperature.

Compressor, Fuel Pump, Combustion Fan, Igniter (Green)

- The compressor, fuel pump, combustion fan, and igniter LED's (Green) turn ON when the component is ON, and will flash if the component is electrically open or shorted.

Flame Out (Red)

- The Flame Out LED (Red) turns ON when a flame fault has been detected.

Voltage Fault (Red)

- The voltage fault LED (Red) turns ON when a voltage fault has been detected.

Low Water (Red)

- The Low Water LED (red) turns ON when a low coolant level in the Oasis® NE-S has been detected.

8.11 Functions of the Zone Control Board

- The Zone Control Board (*Figure 8-5*) contains seven green LED's for *Power, Zone 1, 2, 3, 4 and 5 Thermostats, and Potable Water*.
- It also contains nine matched pairings of red/green LED's for *Zone 1, 2, 3, 4 and 5 Fans, Summer Loop, Heat Loop 1, Heat Loop 2, and Engine Pre-heat Pump*.
- For the Zone Control Board to respond to a call for heat, the coolant temperature inside the Oasis® NE must be above 120F. When thermostats in Zones 1 or 2 call for heat, the cabin fans for those zones will turn ON, and the Heating Loop 1 Pump will activate and circulate hot coolant throughout the loop. When thermostats in Zones 3, 4, or 5 call for heat, the cabin fans for those zones will turn ON, and the Heating Loop 2 Pump will activate and circulate hot coolant throughout the loop.
- When the Engine Pre-Heat switch is turned ON, the Zone Control Board will turn on the Summer Pump and circulate hot coolant through the engine heat exchanger. At the same time, the engine pre-heat pump will turn ON and circulate the engine coolant through the engine heat exchanger.
- When the potable hot water is turned ON, the Zone Control Board will turn on the Summer Pump and circulate hot coolant through the internal potable water heat exchanger.
- When the Burner is turned ON, the Zone Control Board will turn on the Summer Pump and circulate hot coolant through the internal circuit, to provide even heating in the coolant tank.

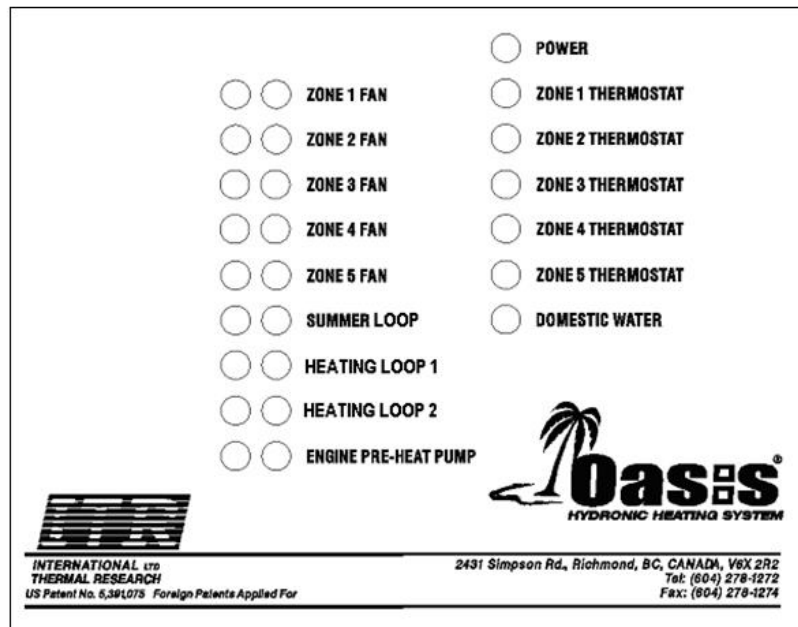

Figure 8-5: Zone Control Board

Power LED (Green)

- The power LED turns ON when the power to the Zone Control Board is ON.

Zone 1, 2, 3, 4, 5 Thermostat LED's (Green)

- The Zone # LED turns ON when the thermostat in the zone is calling for heat.

Potable Water LED (Green)

- The potable water LED turns ON when there is a call for potable hot water.

Zone 1, 2, 3, 4, 5 Fans, Summer Loop, Heat Loop 1, Heat Loop 2, Engine Pre-heat Pump Paired LED's (Red/Green)

- The nine paired LED's indicate the functionality of the corresponding devices. The green LED will turn ON when the device is operating normally. The red LED turns ON if a fuse has been blown.

8.12 Potable Water and Space Heating Priority

- By default, the Zone Control Board is shipped with the heating priority set for potable hot water and space heating to operate simultaneously. This means that when there is a call for potable hot water, space heating will also be available. If the user wishes to support a high flow rate potable water demand without the space heating function a "Priority" jumper located towards the top left of the Zone Control Board can be set to accommodate this feature. (Figure 8-6).

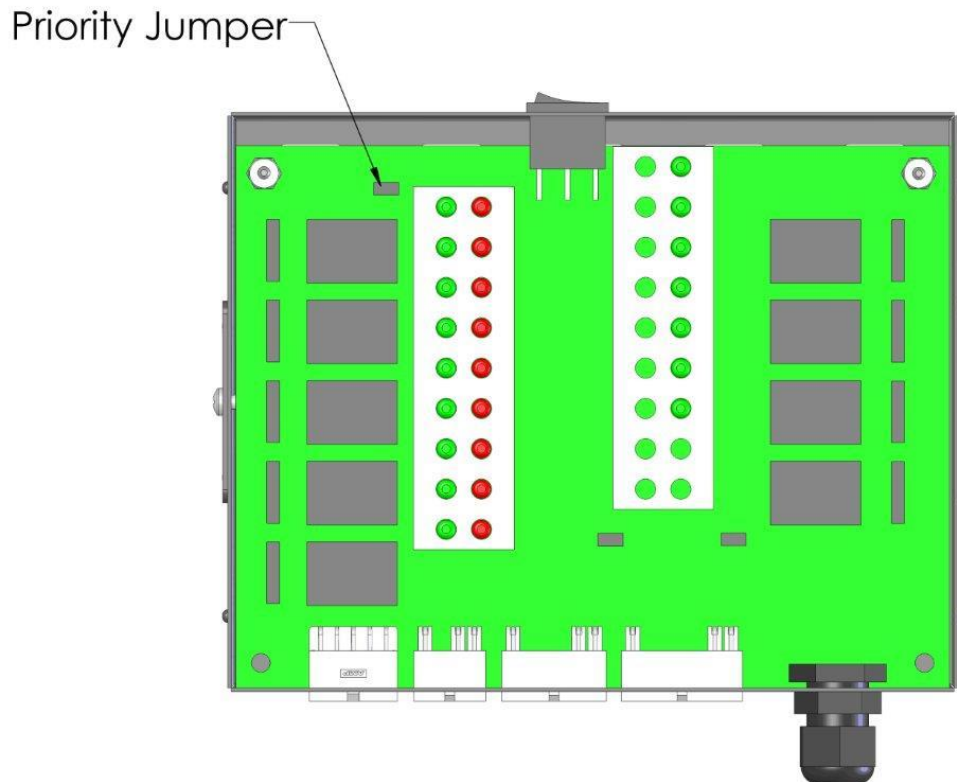

Figure 8-6: Zone Control Board Priority Jumper

8.13 Maintenance

Customer Monthly Maintenance: Check the following and correct as required:

- Coolant hoses and fittings for leaks and integrity.
- Check coolant level in the overflow bottle (3/4 full when hot). **Fill only when the system is COLD and in small quantities only to prevent overfilling.**
- Exhaust fittings, fuel fittings and connections, plumbing fittings and connections, for leaks and integrity.
- Exhaust and air-intake checked for no obstructions.
- Fuel lines, fittings for leaks and integrity.
- External fuel filter for clogging.

Annual Service Requirements: Perform the following:

- **Prior to operation for the season, a factory service tune-up of the Oasis® NE-S Heating System should be performed by trained service personnel.** Only personnel familiar with the equipment and its operation should perform the service tune-up. It is recommended that the dealer be contacted for this service or if not available, contact ITR for information on service resources.
- As a general guide, the regular maintenance items such as the igniter, fuel filters (nozzle filter and external filter), and air compressor filter should be replaced as opposed to inspected and cleaned. Their performance may be deteriorating and/or their remaining service life ending without any apparent visual signs or operating symptoms.
- The major components such as the air compressor, fuel pump, fuel nozzle, and combustion air fan should be examined for wear and should be serviced or replaced by the service technician as required.
- The combustion tube should be inspected by the service technician for wear and replaced if necessary. To access the combustion tube, the front panel of the Oasis® must

be removed along with the burner box cover. The fuel block must then be removed from its mounting position. Finally, the burner and counter-flow tube must be taken out by removing the nuts holding the burner box in position. If the tube is satisfactory, a thorough cleaning of the tube and burner chamber should be performed by blowing out and vacuuming any ash and carbon buildup. Any build up on the surface of the burner chamber will cause the heater to lose efficiency.

- Regular inspection and maintenance is the only way to ensure safe, reliable and efficient operation of your heating system.

8.14 Protecting the Heating System

NOTICE

Protect the Oasis® NE-S Heating System from temperature extremes and any dusty, dirty, corrosive environment.

! DANGER

Protect the Oasis® NE-S Heating System from cold temperatures and corrosion by using a proper mixture of anti-freeze and water. Use only a non-toxic propylene glycol based coolant with additives generally recognized as safe "GRAS" by the FDA in the Oasis® NE-S Heating System. Read and follow the anti-freeze manufacturer's instructions for the type of anti-freeze and mixture recommended for your application.

NOTICE

Note that any potable water in the Oasis® NE-S will freeze in cold temperatures and will damage the internal parts. The potable water heat exchanger must be drained (using provided drain valve) before freezing temperatures are encountered. Alternatively, the potable water system can be flushed with winterizing antifreeze that is safe for use in the potable water lines.

8.15 General Troubleshooting

Ensure that your heating system has both sufficient battery voltage and ground, and coolant level. The Oasis® NE-S is designed not to allow operation if these are incorrect (indicated by a lit Voltage LED or Low Water LED on the Oasis® NE-S Control Panel).

Burner Does Not Start Up

- Oasis® NE-S connected to 12 VDC power?
- Power button on Oasis® NE-S Control Panel pushed ON? Power LED lit on Oasis® NE-S Control Panel?
- Burner switch on Remote Operating Panel ON? Burner LED lit on Remote Operating Panel?
- Main fuse or circuit breaker blown or tripped?

AC immersion elements do not activate

- Primary Electric Element wires on Oasis® NE-S connected to 120 VAC power?
- AC switch on Remote Operating Panel placed in the one or two element position? AC Heat LED is lit on Remote Operating Panel?
- AC immersion elements circuit breakers tripped?

Burner Starts but Flame Faults

- Fuel nozzle plugged or dirty?
- Fuel supply present and adequate?
- Air-intake or exhaust not blocked or obstructed?
- Air in fuel line (white smoke from exhaust or popping sound from exhaust)?
- Fuel filter (external) dirty?
- Restrict the fuel return line with needle valve or pinch off completely.

Burner Starts but Zone Faults

- Power LED on Zone Control Board glowing green?
- Component matched LED pairings all glowing green on the Zone Control Board?
- Fuse blown for one of the pumps or cabin fans on the Zone Control Board?



Warranty Information

Attention Purchaser and Installer

General Warranty

- ITR warrants the OASIS® CH50, OASIS® COMBI, NE, and NE-S (referred to as "heater(s)") DISTRIBUTION MODULE and all accessories or other supplied components with the original purchase to be free of defects in materials and workmanship under design usage and service conditions for ONE (1) year from the heater "in-service" date. Warranty replacement parts are covered for the remainder of the heater's warranty.
- You must install the Product in compliance with the specifications, standards, and instructions in the *Installation Manual*.
- If you need to depart from the manual, you must first consult and obtain the written approval of ITR. Otherwise, your warranty may be voided or limited.
- Systems that are not installed to the published installation instructions (unless with prior written approval of ITR) will be ineligible for warranty coverage.
- Fill in the enclosed Warranty Card completely. It must be signed by the Owner and returned to ITR within 30 days of the date of the original installation. The Owner cannot transfer this warranty. Before mailing, make photocopies of the completed Warranty Card for your records. It will be a valuable reference if you need warranty repairs in the future.

Limited Warranty

The following warranties are in lieu of all other warranties and conditions. ITR makes no other warranties, representations, or conditions, express or implied. Expressly excluded are all implied or statutory warranties or conditions of merchantability of fitness for a particular purpose, and those arising by statute or otherwise in law or from dealing or trade usage.

The stated express warranties are in lieu of all liabilities or obligations for damages arising out of or in connection with the delivery, use, performance, or licensing of the Product or in connection with any services performed. In no event whatsoever will ITR be liable for indirect, consequential, exemplary, incidental, special, or similar damages, including but not limited to, lost profits, lost business revenue, failure to realize expected savings, other commercial or economic loss of any kind or any claim against ITR by any other party arising out of or in connection with the sale, delivery, use, performance, or repair of the Product, or in connection with any services performed, even if ITR has been advised of the possibility of such damages, whether based upon warranty, contract, or negligence. ITR's maximum liability shall not in any case exceed the contract price for the Products claimed to be defective.

No one is authorized to increase, alter, or enlarge ITR's responsibilities or obligations under these warranties.

Owner's Responsibilities

If any warrantable failures occur before the expiration of the warranty, the Owner must give notice of such failures to ITR or to the authorized ITR dealer from which the Product was originally purchased, and obtain written approval for the warranty repair.

The Owner is responsible for the following costs in case of a warrantable failure:

- shipping and insurance costs to deliver the defective Product to the dealer or ITR (if necessary)
- all repairs made to equipment ancillary to the Product, including the vehicle, coach engine, and other associated components of the vehicle in which the Product is installed
- lodging, meals, and other incidental expenses incurred by the Owner as a result of a warrantable failure
- "down time" expenses and all business costs and losses resulting from the warrantable failure

Not Covered Under Warranty

Warranty will be voided or not extended in the following circumstances:

- Owner fails to notify ITR or the authorized ITR dealer from which the Product was originally purchased about a warrantable failure and to obtain prior written approval for warranty repair.
- Original serial number on Product or electrical control board has been removed, altered, or is unreadable.
- Product has been modified or uses non-standard parts not approved by ITR.
- Product has been abused (such as by dropping it), damaged, vandalized, or has received improper maintenance.
- Product has been run dry or operated without appropriate antifreeze, causing damage to the heat exchanger, pump seals, etc.
- Product has been exposed to an environment detrimental to its effective operation, such as excessively wet, dirty, or hot areas.

Also not covered under warranty:

- Parts or Products no longer within the manufacturer's warranty period.
- Parts or Products installed or used in a manner contrary to ITR's printed instructions without ITR's prior written permission.
- Normal wear and tear of parts, including but not limited to, fuel filter, air filter, nozzles, fuses, ignitor, electrical motors, fuel pumps, air compressors, and carbon brushes.
- Product malfunctions due to improper installation of parts or Products, including but not limited to malfunctions causing inadequacies in air, fuel, or coolant flow; voltage problems due to improper wiring; and shock or vibration.

- Progressive damage to the engine or vehicle caused by failure of the Product or an improper installation.
- Diagnosis or repairs to fix problems not directly related to the Product or due to empty fuel tanks or poor fuel quality, fuel additives, acidic water, electrolysis, or any chemical reactions.
- Travel time and expenses by an ITR dealer.
- Removal and re-installation expenses for the ITR heater.

Customer Service Calls

ITR warrants the ITR heater and the Dealer warrants the installation.

If you have a service problem, first check the *Troubleshooting* section of the *Owner's Manual* to determine if your problem is addressed. Also ensure you are familiar with the design and installation setup.

When calling ITR or the Dealer with a service problem, have the following information ready at hand:

- model number and serial number of the Product
- a detailed description of the problem
- your *Installation Manual* and *Owner's Manual*

Depending on your location, an authorized service person may be able to visit your coach or yacht to help troubleshoot problems and repair your Product. Such service calls are at the Owner's expense. Regardless, you must obtain written approval from ITR or the Dealer for any warranty repair before it is undertaken. All repairs done under warranty are subject to the terms and conditions of the flat-rate manual.

Returns

If a service call by an authorized service person is not feasible, the Owner must do the following to obtain warranty service:

1. Immediately contact ITR (or your Dealer) and provide a full description of the problem.
2. Obtain (in writing) a Return or Repair Material Authorization (RMA) number from ITR for any warranty, return, repair, or service. ITR will refuse any return package and will not authorize service or repairs without a RMA number. (For repairs by authorized Dealers, the dealer must obtain an authorized RMA number from ITR before warranty work commences.)
3. When shipping your Product, pack securely, show the RMA and serial number of the Product on the outside of the shipping container, and ship prepaid and insured.
4. Provide written details of the problems, date of installation, proof of purchase, and a return address.

After repair or replacement of the Products still under warranty, ITR will pay return shipping charges. All repairs done under warranty are subject to the terms and conditions of the flat-rate manual.

Telephone / Email Service

Service information given over the telephone, by fax or by email is given only in good faith as an accommodation to the customer. Such information should not be relied upon without an independent verification of its applicability to the customer’s particular situation. For customer service or other information, contact:

IN CANADA:

2431 Simpson Road
Richmond, BC, Canada V6X 2R2
Tel: 1-800-755-1272 or 604-278-1272
Fax: 604-278-1274
Email: info@itrheat.com

IN THE UNITED STATES:

11915 NE 56th Circle, Suite B
Vancouver WA USA 98682
Tel: 1-800-993-4402 or 360-993-4877
Fax: 360-993-1105
Email: info@itrheat.com

Website: <http://www.itrheat.com>

OWNER’S SERVICE LOG:

Date	Service Performed	Service Center