

**INTERNATIONAL LTD  
THERMAL RESEARCH**

# *OASIS™ Heating Module*

## Installation and Operating Manual

Diesel and AC Heating System  
for Recreational Vehicles and Yachts



CSA TIL R-17  
ANSI/UL307A  
CAN/CSA-C22.2 No.165

Copyright © January 2011

**International Thermal Research**

**IN CANADA:**

2431 Simpson Road

Richmond, BC, Canada V6X 2R2

Tel: 1-800-755-1272 or 604-278-1272

Fax: 604-278-1274

Email: [info@itrheat.com](mailto:info@itrheat.com)

**IN THE UNITED STATES:**

11915 NE 56<sup>th</sup> Circle, Suite B

Vancouver, WA, USA 98682

Tel: 1-800-993-4402 or 360-993-4877

Fax: 360-993-1105

Website: <http://www.itrheat.com>

All rights reserved. No part of this manual may be reproduced or transmitted in any form by any means, electronic or mechanical, including photocopying and recording, information storage, retrieval, or transmission, without permission in writing from International Thermal Research

**Right to Modify:**

Due to our commitment for quality and ongoing product improvement, ITR reserves the right to modify or change without notice, any materials, applications, equipment, accessories, and/or prices. All measurements and weights are approximate.

# Table of Contents

<b>Section 1, Overview .....</b>	<b>1-1</b>
1.1	Unpacking the Heating Module ..... 1-2
1.2	Protect Your Warranty ..... 1-2
1.3	Oasis™ Heating Module Features ..... 1-3
1.4	Critical Factors..... 1-5
1.5	Equipment, Tools and Skills ..... 1-6
1.6	Testing and Inspection..... 1-7
<b>Section 2, Mounting the Oasis™ Heating Module .....</b>	<b>2-1</b>
2.1	Before You Begin ..... 2-1
2.2	Identifying Your Oasis™ Heating Module Model. 2-2
2.3	Your Mounting Location..... 2-2
2.4	What NOT to Do..... 2-4
2.5	Procedure ..... 2-4
<b>Section 3, Installing the Exhaust System.....</b>	<b>3-1</b>
3.1	Before You Begin ..... 3-1
3.2	Mounting Location ..... 3-1
Recommended Exhaust Outlet Locations.....	3-1
Recommendation for Installation .....	3-2
What NOT to Do.....	3-4
3.3	Procedure ..... 3-4
<b>Section 4, Installing the Fuel System .....</b>	<b>4-1</b>
4.1	Before You Begin ..... 4-1
4.2	Fuel System Operation..... 4-1
Recommendations for Installation.....	4-1
4.3	What NOT to Do..... 4-2
4.4	Procedure ..... 4-3
<b>Section 5, Installing Fan Heaters.....</b>	<b>5-1</b>
5.1	Before You Begin ..... 5-1

5.2 Fan System Operation ..... 5-2  
    Features ..... 5-2  
    Multiple Zone Heating ..... 5-3  
    Accessories and Components Needed ..... 5-3  
5.3 What NOT to Do ..... 5-4  
5.4 Mounting Locations ..... 5-4  
5.5 Procedure ..... 5-5

**Section 6, Wiring the Electrical System ..... 6-1**

6.1 Before You Begin ..... 6-1  
6.2 12 VDC ..... 6-1  
6.3 120 VAC ..... 6-2  
6.4 Remote Operating Panel Cable ..... 6-2  
6.5 Main Electronic Control Board ..... 6-3  
6.6 Distribution Module Zone Control Board  
    (Optional) ..... 6-3  
6.7 What NOT to Do ..... 6-4

**Section 7, Plumbing the System ..... 7-1**

7.1 Before You Begin ..... 7-1  
7.2 Plumbing Installation ..... 7-1  
7.3 What NOT to Do ..... 7-4  
7.4 Installation Procedure ..... 7-4

**Section 8, Operating the Oasis™ Heating Module ..... 8-1**

8.1 Features of your Oasis™ Heating Module ..... 8-1  
8.2 Your Heating Module Model ..... 8-2  
8.3 Operating Instructions for the  
    Oasis™ Heating Module ..... 8-3  
8.4 Turning the Power to the  
    Oasis™ Heating Module ON ..... 8-4  
8.5 Activating the Burner (Primary)  
    and AC Heat (Secondary) from the  
    Remote Operating Panel ..... 8-5  
8.6 Activating the Cabin Fan Heaters  
    through the Thermostats ..... 8-6  
8.7 Activating the Domestic Hot Water ..... 8-6  
8.8 Activating the Engine Heat ..... 8-6  
8.9 Functions of the Remote Operating Panel ..... 8-7  
8.10 Functions of the Heating Module Control Panel .. 8-9

8.11	Functions of the Distribution Module (Optional) Zone Control Panel .....	8-10
8.12	Maintenance .....	8-11
8.13	Protecting the Heating Module and Distribution Module (Optional) .....	8-13
8.14	General Troubleshooting .....	8-13

**Section 9, Installing Distribution Module, DM-12  
(optional) ..... 9-1**

9.1	Installing your Distribution Module (optional) ...	9-1
9.2	Selecting the Module Location .....	9-1
9.3	Selecting the Distribution Module Zone Box Location .....	9-2
9.4	Plumbing Installation .....	9-3
9.5	Filling/Purging the heating loop .....	9-7
9.6	Electrical Connection .....	9-8
9.7	Distribution Module Zone Control Board.....	9-9
9.8	Inspection and Testing .....	9-12
9.9	Hot water temperature adjustment .....	9-12

**Warranty Information & Warranty Card**

## List of Figures

Figure 1-1	Oasis™ Module .....	1-1
Figure 1-2	Oasis™ Heating and Distribution Module .....	1-5
Figure 2-1	Module Dimensions .....	2-3
Figure 2-2	Module Mounting Brackets .....	2-5
Figure 3-1	Installing the Exhaust System (Bottom Exhaust) .....	3-6
Figure 3-2	The Exhaust Hole Location & Mounting Template .....	3-6
Figure 3-7	The Exhaust Goose neck Configuration .....	3-7
Figure 5-1	Wiring the Fan's Aquastat .....	5-2
Figure 5-2	Mounting a Spacesaver Fan .....	5-6
Figure 5-3	Installing a Relay for Add'l Fan Amperage .....	5-6
Figure 6-1	System Wiring .....	6-3
Figure 7-1	Heating Module .....	7-3
Figure 7-2	Three Approved Methods of Installing Heater Hose (consult ITR for alternative methods and products) .....	7-5
Figure 8-1	Oasis™ Heating Module .....	8-3
Figure 8-2	Heating Module Main Control Panel .....	8-4
Figure 8-3	Remote Operating Panel .....	8-7
Figure 8-4	Zone Control Panel .....	8-11
Figure 9-1	Distribution Module .....	9-2
Figure 9-2	Distribution Module Zone box .....	9-2
Figure 9-3	Distribution Module Fittings Location .....	9-3
Figure 9-4	Domestic Hot Water System Plumbing .....	9-4
Figure 9-5	Engine Heat / Pre-heat System Plumbing .....	9-5
Figure 9-6	Connecting to the OASIS Heating Module .....	9-5
Figure 9-7	Connecting two Heating loops .....	9-6
Figure 9-8	Initial fill up Oasis system .....	9-7
Figure 9-9	Distribution Module Wiring .....	9-10
Figure 9-10	Zone Board Wiring (No Distribution module) .....	9-11
Figure 9-11	Mixing valve location .....	9-12

# Overview

Thank you for purchasing the Oasis™ Heating Module for recreational vehicles and yachts.

## NOTICE

**The Oasis™ Heating Module is LC certified only for installation into Recreational Vehicles, Manufactured Homes, and Mobile housing.**

This section covers critical information you need to know before beginning the installation including how to protect your Warranty, and tools and equipment needed.



**Figure 1-1: Oasis™ Heating Module**

## 1.1 Unpacking the Oasis™ Heating Module

When you receive the Oasis™ Heating Module:

- 1 Unpack it carefully.
- 2 Check each component against the shipping list to ensure that you have everything and that all parts arrived undamaged.
- 3 If you discover any missing or defective parts call ITR immediately.
- 4 If you are not installing the Oasis™ Heating Module right away secure all components so none will be misplaced.
- 5 **Before installing the Oasis™ Heating Module read the rest of this Installation and Operating Manual. It contains critical information for a proper installation.**

A properly installed Oasis™ Heating Module is essential for several reasons:

- To ensure that you and/or your customers receive satisfactory results and enjoy a warm, comfortable environment.
- To ensure a trouble-free installation, a successful inspection and testing process, and ease of future maintenance.
- To protect your Warranty.

## 1.2 Protect Your Warranty

This document reflects approved installation techniques, methods, and materials, and applies only to ITR equipment. The Oasis™ Heating Module is only guaranteed by ITR if the entire system has been installed according to the requirements and recommendations set out here.

This includes:

- Deviations from the instructions in this Manual.
- Changes to any piece of ITR-supplied equipment.
- Substitution of a non-ITR approved component.

No Warranty will be extended to improper installations. Use of any unapproved materials, equipment or installation procedures will



result in a voided warranty for the entire heating system. Any loss of service or damage as a result of any unapproved modification is the responsibility of the installer. ITR accepts no liability for any damage or loss of service resulting from unapproved modifications.

- Efficient
- Clean
- Quiet
- Compact
- Safe
- Rugged
- Reliable
- Economical

### 1.3 Oasis™ Heating Module Features

The Oasis™ Heating Module uses a diesel burner (12 VDC) controlled by a multi-functional electronic controller as the primary source of heating coolant fluid (anti-freeze and water). Two 1500 Watt, 120 VAC immersion elements are used as secondary heat sources. The Oasis™ Heating Module heats the coolant fluid to provide a source of heat for all hydronic space heating needs. When used with the Distribution Module (optional) and its integral distribution pumps, the Oasis™ Heating Module has the ability to circulate the coolant fluid to all space heating areas. It can also provide a supply of domestic hot water using the integral heat exchanger in the Distribution Module. The Oasis™ also incorporates engine heat and preheat functions. (see *Figure 1-2: Oasis™ Heating and Distribution Modules*).

Other features of the Oasis™ Heating Module include:

- A high-temperature, stainless steel burner and stainless steel jacket.
- 8.2 US gallon welded, insulated stainless steel coolant tank that minimizes heat loss and optimizes heat recovery.
- Low coolant level switch on the tank.
- Easy to install, completely modular and field serviceable with the Oasis™ Heating Module hookups and connections easily accessible from the front and top of the Heating Module.
- Quiet operation and low power consumption.
- Low pressure fuel system with built-in fuel pump.
- Fuel efficient burner capable of burning a wide variety of diesel-based fuels.
- Exhaust has minimal smoke and smell.

- Fan assisted sealed combustion chamber is designed to use outside combustion air.
- Simple, low amperage draw ignition.
- Electronically-controlled system with:
  - automatic Safety Shutdown;
  - manual-resettable aquastats for safety overheat protection.
  - LED indicators on the Control Panel for diagnostics.
  - Patented, proprietary flame sensor.
- Heating Module Remote Operating Panel with ON/OFF switch for the diesel burner, AC elements, and engine heat, if installed.
- Heating Module Control Panel with buttons for Power, Bypass, Reset, and indicator LED's for operational and diagnostic information.
- Distribution Module if installed with built in distribution pumps and heat exchanger for heating multiple zones and also producing domestic hot water. Heat exchanger also allows engine pre-heating as well as using engine waste heat. The Zone Board Controls up to five space heating zones.

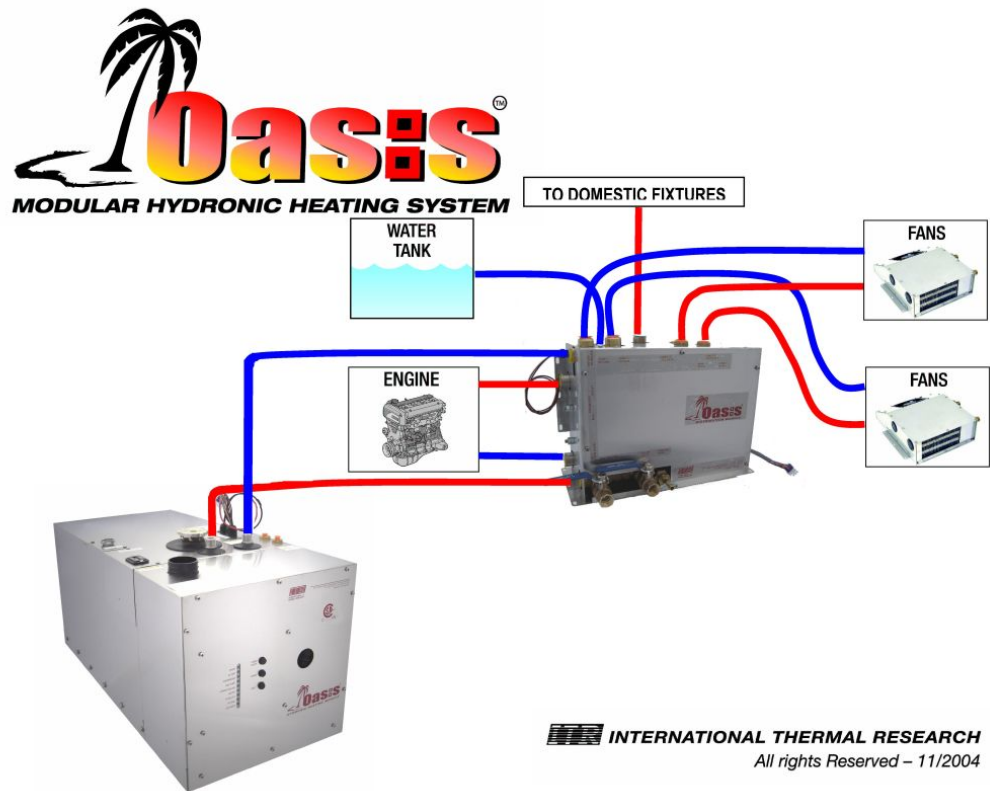

Figure 1-2: Oasis™ Heating and Distribution Module

## 1.4 Critical Factors

THE INSTALLATION SHALL BE IN ACCORDANCE WITH THE REGULATIONS OF AUTHORITIES HAVING JURISDICTION

Pay attention to the notices of "Danger" "Warning" "Caution" and "Notice" in this manual.

The key factors to keep in mind when planning and carrying out the installation are:

- Mounting location restrictions for the Oasis™ Heating Module, optional Distribution Module, and exhaust outlet (to reduce noise, vibration, heat loss, etc.).
- Length, routing and sizing of fluid lines, fuel lines, air-flow tubing, exhaust piping and wiring.
- Unrestricted vent required to draw in 100% outside air for combustion.

- Ability for technician to easily access and service the product, especially fuel, plumbing, and electrical systems.
- After installation, ability to purge water and fuel lines and inspect/test entire system using the ITR-supplied Inspection Check Sheet.

## 1.5 Equipment, Tools and Skills

As the user and/or installer, you must be qualified and authorized to do the installation, which requires mechanical aptitude and electrical knowledge. Make sure you comply with existing RVIA or ABYC industry practices, using the highest and most recent standards and codes. Good workmanship is essential. Please refer back to *Section 1 – Overview, sub-Section 1.2, Protect Your Warranty*.

You will need the following equipment and tools to install the heating system (not supplied). This list does not include optional equipment and accessories:

- Standard tools normally available in a well-equipped shop.
- Approved fasteners for mounting the heater unit.
- Steel (or stainless steel) 2" ID exhaust system piping, maximum 12' with no bends. (See *Section 3 – Installing the Exhaust System*, for details when bend are present.).
- Exhaust collar.
- ITR-muffler with straight-through design.
- 1/4" supply fuel line, approved rubber or copper.
- #10 sheet metal screws or wood screws to mount fan units inside the occupied areas.
- Heater hose (to connect optional Distribution Module hose fittings to interior fans).
- Domestic water hose and/or tubing to connect the Distribution Module hose fittings to the domestic water system.
- Overflow tank to connect to the Oasis™ Heating Module with clear plastic 3/8" hose; tank must be heavy-duty plastic, with a

screw-down cap, and sturdy enough to mount firmly to a vertical surface.

- Up to five (5) thermostats (DC compatible) to allow temperature regulation of the heating zones when connected to the Distribution Module.

## 1.6 Testing and Inspection

After all components have been properly installed according to standard practices, RVIA or ABYC standards, and the recommendations of this Installation and Operating Manual, the Oasis™ Heating Module should be test-operated for inspection purposes.

For your convenience, you can use the pullout *Inspection Check Sheet* in this Manual. The Inspection Check Sheet is divided into progressive sections, allowing each phase of the inspection to be carried out systematically, and then signed off by authorized persons.



# Mounting – Oasis™ Heating Module



## 2.1 Before You Begin

Plan the location of the Oasis™ Heating Module and all its major components in advance to ensure the chosen locations are compatible with installation requirements and within the technical specifications.

Consider the following factors to help you decide exactly where best to mount the Oasis™ Heating Module:

- Oasis™ Heating Module weight when full (160 lbs).
- Ventilation requirements.
- Exhaust outlet location and maximum acceptable length.
- Thru hull location and waterline (yachts).
- Potential for vibration and jarring.
- Length of run from fuel source to heater.
- Most efficient plumbing runs.
- Safe and convenient access for maintenance.
- Number and location of interior fans.
- Location of other equipment to be installed or connected to the Oasis™ Heating Module, including the optional Distribution Module, Zone Control Box, heat exchangers, overflow tank, batteries, etc.

**! WARNING**

---

Make sure you are familiar with *Section 1 – Overview* of this Manual. If the system is not installed according to specifications and with the correct equipment, your Oasis™ Heating Module may not operate properly, safety may be compromised, and your Warranty may be voided.

---



## 2.2 Identifying Your Oasis™ Heating Module Model

As the owner, you must be fully aware of the controls and operating features particular to your model of the Oasis™ Heating Module. This is essential for the proper functioning and life of your Oasis™ Heating Module as well as protecting your warranty. Your model can be identified by locating the serial number label on the outside case of the Oasis™ Heating Module. The serial number identifies the model type through the first series of letters and numbers.

The types of Oasis™ Heating Module models are:

CH50S – Oasis™ Heating Module (Stainless Steel Case)

CH50B – Oasis™ Heating Module (Galvanized Case)



## 2.3 Your Mounting Location

Your mounting location should consider the following:

- Mounting location must be able to support double the gross weight of the Oasis™ Heating Module (i.e. 160 lbs. x 2 = 320lbs./73 KG x 2 = 146 KG) and must be of a non-combustible and non absorptive surface.
- Oasis™ Heating Module is 14"H x 14"W x 30" D. (35.6 cm x 35.6 cm x 76.1 cm), see *Figure 2-1: Module Dimensions*.
- Oasis™ Heating Module must be installed in a compartment which is completely isolated from the atmosphere of living spaces.
- Combustion air must be drawn from an outside source and cannot contain any combustible gases.



## Section 2, Mounting the Oasis™ Heating Module

- Oasis™ Heating Module must be mounted in an area that provides unrestricted access to the front panel. Allow space for connection to the fuel and coolant lines, as well as the power and exhaust connections. (Minimum of 10" top clearance - top exhaust version; minimum of 6" top clearance - bottom exhaust version; 0" clearance to all other Oasis™ Heating Module surfaces). Allow 1" clearance on the sides for attaching the mounting brackets.
- Mount the unit with the front panel side facing out and accessible. Facing out simplifies installation and maintenance.
- Oasis™ Heating Module must be mounted horizontal and level using eight, 1/4" through bolts and 1" diameter fender washers, lock washers and nuts.

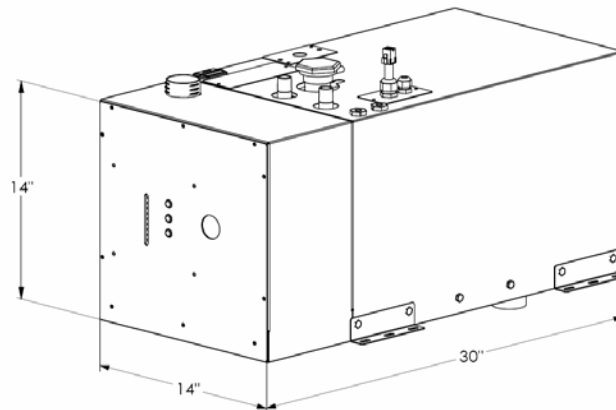

**Figure 2-1: Module Dimensions**

### **! DANGER**

Oasis™ Heating Module must not be installed or operated in any compartment with flammable gases.

### **! WARNING**

If the Oasis™ Heating Module is going to be mounted in the engine compartment, check for adequate ventilation. When the engine is running this area could be under a negative pressure. Make sure the air-intake and exhaust hoses have no leaks and are well fastened to the heater, muffler and thru-hull fitting. Assembly parts that may cause injury through accidental contact should be protected.

**! DANGER**

---

Isolate the unit in a closed compartment so that no air from the heater will infiltrate the living areas.

---

- It is recommended that a catchpan be placed under the Oasis™ Heating Module for containing any unexpected leakage.
- Choose a sturdy surface in a location that won't be unduly affected by vibration and the jarring of rough roads or rough seas.
- Ensure that the exhaust tubing can be properly and safely routed to the outside. The maximum exhaust run for the system is 12'.



## 2.4 What NOT to Do

- **Don't** mount the Oasis™ Heating Module in the rear of the coach or yacht underneath the sleeping area. The sound of the Oasis™ Heating Module cycling on and off may disturb light sleepers.



## 2.5 Procedure

After choosing the mounting location for the Oasis™ Heating Module, mount the module horizontally and level. Secure the Oasis™ Heating Module in place (against the wall, floor or a mounting platform) using eight (8) x 1/4" through bolts and 1" diameter fender washers, lock washers, and nuts. (See *Figure 2-2: Module Mounting Brackets.*)

Section 2, Mounting the Oasis™ Heating Module

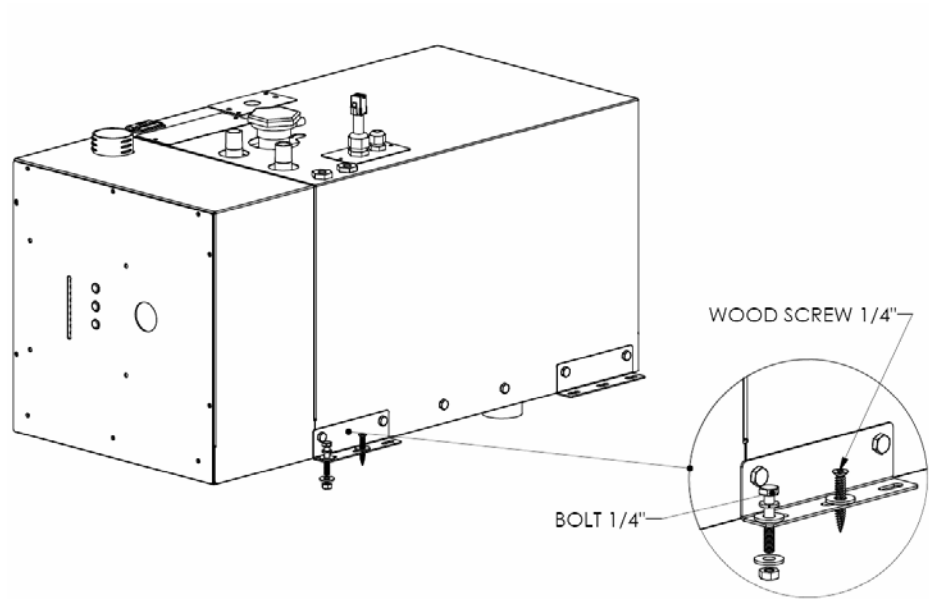

Figure 2-2: Module Mounting Brackets



# Installing the Exhaust System



## 3.1 Before You Begin

For efficient and safe operation of the Oasis™ Heating Module follow all recommendations for properly installing the exhaust. Any deviations from these must be approved in advance by ITR.

### ! DANGER

---

Although the heater's exhaust produces very low carbon monoxide emissions, caution is still advised:

- Do not operate the Oasis™ Heating Module in an enclosed area unless there is adequate ventilation.
- Isolate the Oasis™ Heating Module in a closed compartment so that no air from the unit will infiltrate the living areas.

Never place any exhaust parts close to combustible material or through a combustible wall or ceiling without fireproof protection. The exhaust can reach high temperatures.

---

## 3.2 Mounting Location

**If you can't meet the technical specifications for mounting the exhaust, don't use the Oasis™ Heating Module. The unit may perform poorly or become damaged if not installed according to specifications.**



### Recommended Exhaust Outlet Locations

The following is recommended for a coach exhaust outlet location:

- Mount the exhaust outlet **outside** the coach, not inside the heater compartment. Otherwise, exhaust fumes could infiltrate the coach from the Oasis™ Heating Module.

- In a coach, the typical mounting location for the exhaust outlet is under the floor of the Oasis™ Heating Module compartment, or on the other side of the coach, directly across from the module. Keep in mind you cannot exceed 12' of exhaust piping, without any bends, or 8' with two 90°, 2" minimum radius bends.
- Position the outlet of the exhaust pipe so that the exhaust exits off the side of the coach, not directly underneath the coach or under an opening window, vent or slide-out.

In a yacht installation, the following is recommended for the exhaust outlet location:

- Mount the exhaust thru hull so that the exhaust fumes cannot enter or re-infiltrate any living areas.
- Make sure that the thru hull is at least 30" above the water line with a goose neck rise on the exhaust to help eliminate water from getting to the Oasis™ Heating Module through the exhaust. If the dual exhaust air-intake thru hull is used, ensure that the air-intake is placed between 10 o'clock and 2 o'clock and also goose-necked to avoid water ingestion, see *Figure 3-3: The Exhaust Goose Neck Configuration*.
- There needs to be a 1/8" air gap around the exhaust thru hull. The standard thru hull is 4" in diameter. The hole for the fitting should be 4-1/4". Make sure that the holes for the mounting screws have enough material left to properly bite. The fitting must be centered in the hole.



### Recommendation for Installation

The following applies to both a coach and yacht:

- You may use sweep bends but each 90° bend is equivalent to two foot of exhaust piping. For example, if you use two 90° bends you must deduct two foot per bend from the maximum allowed 12' straight exhaust pipe length. Therefore you will be restricted to 8' of straight exhaust piping plus the two bends. Do not exceed these recommendations.
- The combustion air must be drawn from outside the coach or yacht. The maximum length of the air-intake tubing is 7 feet. Do not exceed this recommendation.

- Use an ITR-manufactured muffler with a straight-through design. No other muffler is acceptable.
- Exhaust outlet is on the top or bottom (model dependant) of the Oasis™ Heating Module, towards the back.

**! DANGER**

---

**The exhaust and outlet are HOT and the surrounding areas must be thermally shielded and protected from the hot surfaces and heat build-up by insulation. Nothing can come into inadvertent contact with any part of the exhaust system.**

---

- Exhaust must have a minimum of 3" (7.6 cm) clearance from all surfaces.
- Ensure that the exhaust cannot be plugged or restricted.
- The exhaust fitting on the Oasis™ Heating Module is 2.0" O.D. and the exhaust pipe used must have a minimum of 2.0" I.D. throughout its length.
- All exhaust elbows must be of a large radius design.
- The exhaust must be supported a minimum of every 3' of its installed length.
- The exhaust and Oasis™ Heating Module connection point must use appropriate clamps and sealing compound to ensure that the connections are tight and leak free. The Oasis™ Heating Module exhaust outlet pipe and the exhaust pipe itself must not be distorted or damaged during this process.
- When the Oasis™ Heating Module is running the connection points and the system must be checked for leaks and any found must be corrected. Periodically, check the exhaust fittings, connections, exhaust tube, and insulation for leaks and integrity and correct if required.
- Appropriate exhaust insulation must be used to cover the entire length of any interior exhaust run.
- Solid stainless steel exhaust tubing or approved exhaust tubing is recommended but an approved stainless steel flexible exhaust tubing can also be used. If flexible exhaust tubing is used, the exhaust tubing must be inspected regularly for leaks and deterioration as this type of exhaust does not have the life expectancy of solid tubing. Stepped

band clamps are recommended for joining flex and solid tubing as they apply firm, even pressure.

- In a coach, install an exhaust collar on the exhaust pipe to isolate the pipe from the coach frame. This reduces vibration and noise and protects the coach from the effects of high exhaust temperature, see *Figure 3-1: Installing the Exhaust system (Bottom Exhaust)*.



#### What NOT to Do

**Don't** mount the exhaust pipe inside the heater compartment.

**Don't** use more than 8' of exhaust pipe if 180° of total bends are present.

**Don't** use any mufflers not supplied or approved by ITR.

**Don't** over-tighten exhaust clamps or you may crush the Oasis™ Heating Module's exhaust outlet pipe.



### 3.3 Procedure

*Figure 3-1: Installing the Exhaust System (Bottom Exhaust)* shows a standard setup for the down exhaust. To install the exhaust system:

- 1** Leave suitable air spacing to protect combustible materials; use an exhaust collar and metal shields where required.
- 2** Find an appropriate location for the exhaust hole of the heater. (See Figure 3-2)
- 3** Securely seal the exhaust piping to the Oasis™ Heating Module fitting using an approved exhaust clamp.
- 4** Connect the exhaust piping in series with the muffler, using heavy-duty exhaust clamps. If you use vibration isolation mounts they must be high temperature.



- 5 Connect the flexible air-intake tubing (2" I.D.) to the air-intake fitting on top of the heater. Use a #32 gear clamp to attach the tubing to this fitting.

The other end of the air-intake hose can be installed in 2 configurations:

**Installation of the air-intake adapter to the underside of the RV**

Locate a suitable location to mount the air-intake adapter. Drill a 2" hole through the floor. Insert the adapter from underneath and use 3 screws to secure against floor. The air entrance of the air-intake assembly shall be guarded or shielded to exclude rain, snow and debris. Use a #32 gear clamp to attach the tubing to this adapter. Ensure the run of tubing is as short as possible to facilitate air flow. See figure 3-1.

**Installation of the air-intake adapter to the side of the RV**

Locate a suitable location to mount the air-intake adapter. Drill a 2" hole through the side wall (minimum ¼", maximum 2" wall thickness). Insert the adapter and use 3 screws to mount against side wall. Use a #32 gear clamp to attach the tubing to this adapter. Ensure the run of tubing is as short as possible to facilitate air flow. See figure 3-1.

- 6 Secure both ends of the air-intake tubing with properly sized hose clamps to prevent air leaks.
- 7 Make sure the air-intake and exhaust hoses have no leaks and are not touching each other.
- 8 Protect the air-intake entrance from water and dirt with a guard or shield.
- 9 On a yacht, make sure the thru hull is at least 30" above the waterline and the exhaust must be goose-necked, see *Figure 3-3: The Exhaust Goose Neck Configuration*.

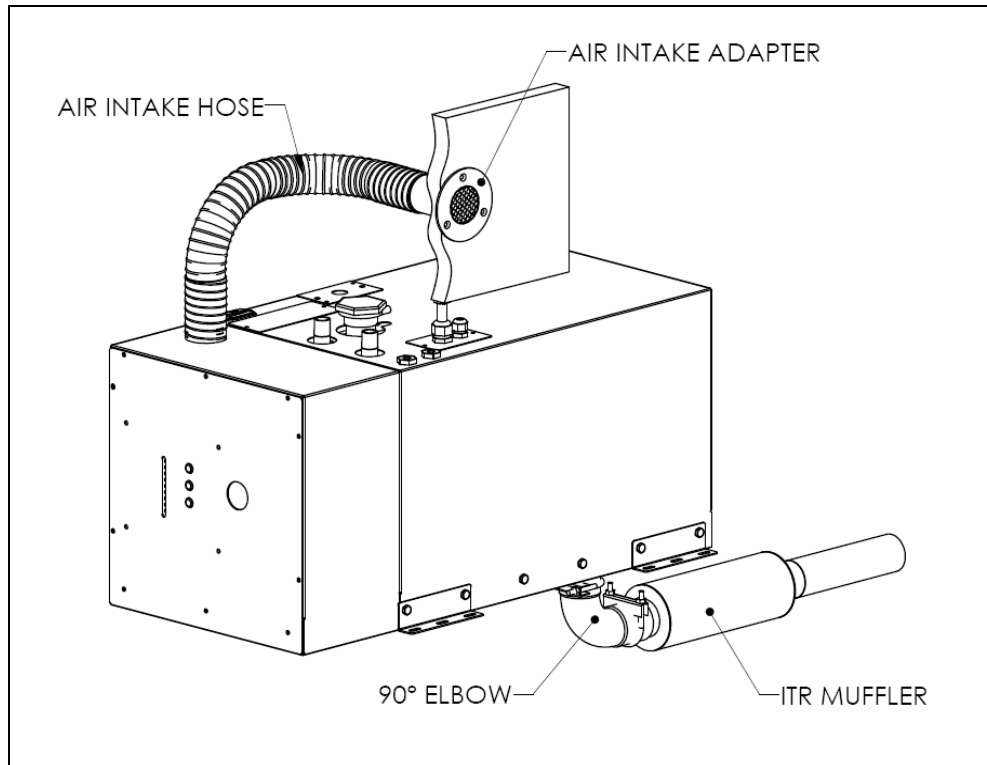

Figure 3-1: Installing the Exhaust System (Bottom Exhaust)

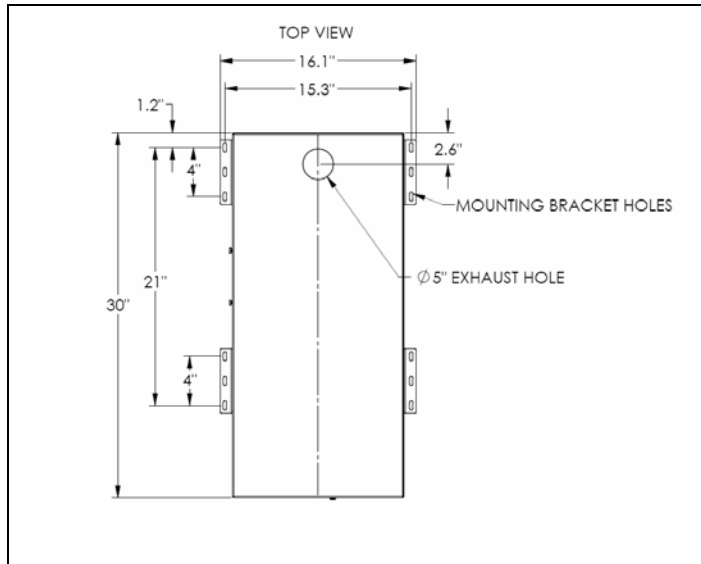
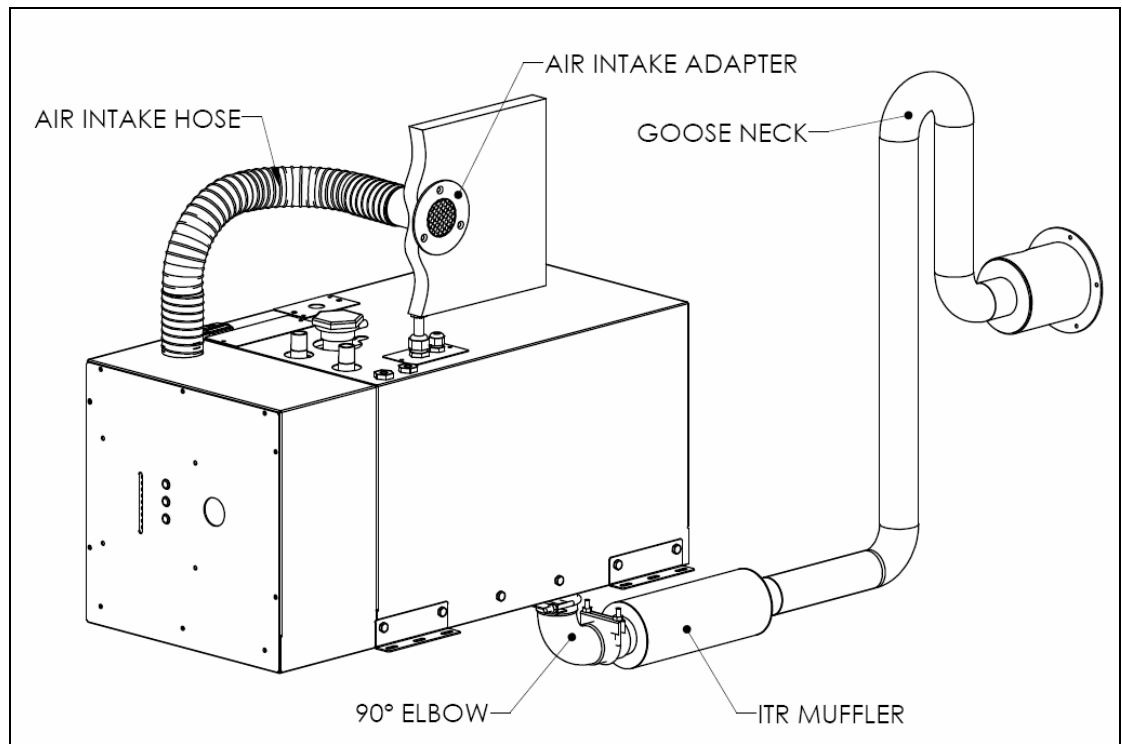

Figure 3-2: The Exhaust Hole Location & Mounting Template

### Section 3, Installing the Exhaust System



**Figure 3-3: The Exhaust Goose Neck configuration**



# Installing the Fuel System

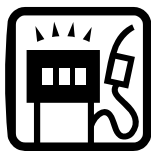

## 4.1 Before You Begin

For efficient and safe operation of the Oasis™ Heating Module, follow all recommendations for properly installing the fuel system. Any deviations from these must be approved in advance by ITR.

### ! DANGER

---

Use only diesel fuel, furnace oil, or stove oil in the Oasis™ Heating Module. **DO NOT USE GASOLINE, CRANKCASE OIL, OR ANY OIL CONTAINING GASOLINE.**

Keep fuel lines away from any heat source above 100°F (38°C).

Keep gasoline and any equipment that uses gasoline away from the Oasis™ Heating Module location. The Oasis™ Heating Module is not rated for use in an explosive environment.

### ! WARNING

**Never** share the fuel supply to the Oasis™ Heating Module with any other fuel-burning device.

---

## 4.2 Fuel System Installation

The fuel pump in the Oasis™ Heating Module has a maximum flow capacity of 25 GAL/Hr and a maximum pressure of 11.5 psi. A 10 micron fuel filter is recommended. Select a fuel filter based on these requirements.



### Recommendations for Installation

The Oasis™ Heating Module's fuel connection is accessed from the top of the heater. The fuel inlet, labelled, is located on the top right of the Oasis™ Heating Module and consists of a 1/8" NPT threaded female fitting. The fuel return, labelled, is located next to the fuel inlet and consists of a 1/8" NPT threaded female fitting. Minimum

recommended size for the fuel line is ¼" I.D. The fuel return line should return to the fuel supply tank.

The following is recommended for the fuel system installation:

## NOTICE

---

The fuel supply from the fuel storage tank to the fuel inlet must be from a dedicated fuel pickup on the top of the tank.

---

- The fuel supply line should be installed with minimal rise from the fuel tank. The total rise from the bottom of the pickup tube to the fuel inlet on the Oasis™ should not exceed 60". There are no minimum clearance requirements between the fuel tank and the Oasis™.

## ! CAUTION

---

The fuel line must be run and secured so as to prevent damage, chafing and kinking during normal operation.

---

- All fuel line connection points and hoses must use suitable clamps and/or sealant and must be checked for leaks on the initial installation and also periodically as part of normal maintenance.
- A primary, UL and/or CSA approved fuel oil filter (not provided) must be installed inline in the fuel supply hose, between the tank and the Oasis™ Heating Module, in a manner that ensures easy access for maintenance. A secondary fuel filter is mounted inside the Heating Module case. Both filters must be inspected and replaced as required as part of normal maintenance.
- Fuel line hose used must be appropriate for your requirements. It is strongly recommended that the hoses have permanently installed end fittings.



### 4.3 What NOT to Do

- **Don't** allow the fuel or the fuel lines to become contaminated with foreign material.
- **Don't** allow the fuel lines to become damaged or constricted.

**! CAUTION**

---

Ensure that fuel lines are always protected from contamination by foreign material. When installing or servicing, seal off ends to prevent contamination. After installing, you may also wish to flush the fuel line to rid of it air and any foreign material.

---



## 4.4 Procedure

To complete the fuel system installation:

- 1** Install the inline fuel filter. The optimal location is on a compartment wall next to the Oasis™ Heating Module, inline between the fuel tank and the Oasis™ Heating Module.
- 2** Connect the fuel line to the dedicated fitting on the main diesel fuel tank.
- 3** Inspect the supply fuel line for any loose connections or damage. Fittings must be airtight.
- 4** If desired, install a shut-off valve on the tank side of the fuel filter to allow shutdown and filter service.





# Installing Fan Heaters – with “Distribution Module” Only



## 5.1 Before You Begin

ITR makes a variety of fan heaters for individual cabins or areas. There are Cabin heaters and Spacesaver heaters (where space is limited). These heaters draw as little as 0.9 amps and deliver 140 cfm. These heaters also come in high output versions and the above numbers are increased by 40%. They should be mounted as close to the floor as possible. They have a built-in aquastat (optional), which turns on the fan when the water running through it reaches 120°F (49°C).

The Defrost Heater, provides up to 28,000 BTU/h and uses a three speed fan, 200/275/450 cfm, 40/55/100 watts.

**Note: A limited number of fan heaters can be used with the Oasis™ Heating and Distribution Modules.**

### NOTICE

---

Only the installation of ITR fan heaters is covered in this Manual.

If you are installing non-ITR fan heaters, you must obtain prior approval from ITR. You must check the fans' total amperage draw to ensure they will be compatible with the Zone Control Board (optional), as well as flow capacity to ensure that each fan meets system requirements.

---

## 5.2 Fan System Operation

ITR fans consist of a 12 VDC brushless fan and heater coil similar to a radiator.

When the heater unit comes on, the fan draws ambient air from the interior, blows it through the heater coil and back into the interior through a vent. There must be an input and output vent for each fan unit.

### Features

- ITR heater fans can be supplied with a built-in aquastat, which prevents fan operation until the system has reached minimum operating temperature. The aquastat can be deleted to meet particular installation requirements, but it is recommended that all systems be installed with the air fan aquastat. *Figure 5-1* shows how to wire up the aquastat in a fan.

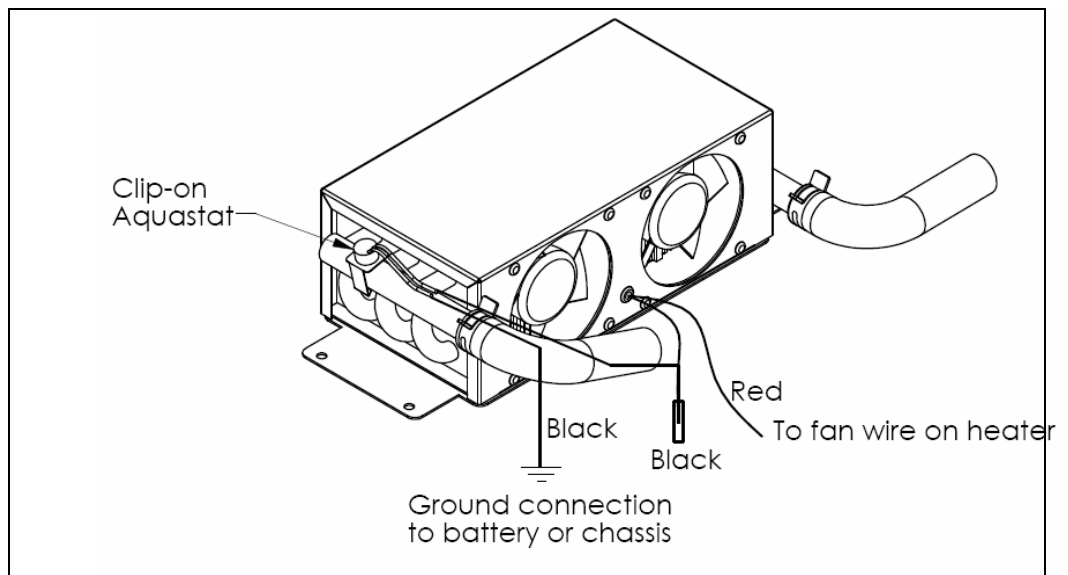

**Figure 5-1: Wiring the Fan's Aquastat**

- If a "passive" radiant heat system is desired (i.e. baseboard or fin and tube configurations), consult ITR for recommended installation procedures and design.

## Multiple Zone Heating

The Oasis™ Heating Module can supply heat up to five interior zones using the Distribution Module (Optional). Refer to *Section 9 – Installing Distribution Module*.

Up to five thermostats (positive DC compatible) can be installed to allow temperature regulation of the zones. The thermostat controls the fan heater.

For larger installations, consult ITR.

## Accessories and Components Needed

In addition to the fans themselves, you will need at least some of the following optional accessories and equipment which are not supplied but which can be purchased separately.

- **Thermostats** — thermostats can be installed in the interior.
- **Air Outlet Vents** — covers that are installed flush with the wall to vent heat for the installed heater unit.
- **Fan Guards** — to protect the fan blades from damage, recommended for fans installed in storage areas or other accessible areas where something could contact the fans.
- **Screws** — #10 sheet metal screws or wood screws to mount the fan units. See *Figure 5-2: Mounting a Spacesaver Fan*.
- **Two-Speed Fan Switches** — to enable low and high-speed settings from inside the coach or yacht; for use with the ITR Cabin heater and Spacesaver fan.
- **Three-Speed Fan Switches** — to enable low, medium and high-speed settings from inside the coach or yacht; for use with the ITR defrost heater.
- **Air Ducting** — to allow you to install fans in a remote location (i.e. not directly adjacent to the interior space to be heated) and duct the heated air to its output location. Also, **air outlet plates** to allow you to install ducting for one, two or three separate outlets

(e.g. you can use one fan to heat two different areas by installing a dual air outlet plate).



### 5.3 What NOT to Do

- **Don't** install more fans that require more heat than the Heating and Distribution Module can produce. Your system will not run effectively. (If you choose to use a higher-draw fan motor (more than 5 amps), install a relay to handle the extra load; see *Figure 5-3: Installing a Relay for Additional Fan Amperage*.)
- **Don't** mount the return air outlet too close to the fan's air intake source.



### 5.4 Mounting Locations

Carefully choose the mounting locations of your fans:

- Locate the fans to evenly heat the zone.
- Provision must be made to protect water lines from freezing.
- Install fan at floor level or very near floor level, in order to optimize circulation.
- Allow a minimum 16 square inch (100 cm sq.) opening in the fan heaters' mounting compartment to allow sufficient intake of air.

ITR can suggest optimal fan locations if you provide a floor plan of your coach or yacht.



ITR's Spacesaver fan (pictured at left) has two stainless steel mounting brackets welded to the side of the case. It is designed to be mounted horizontally on a flat surface. This fan can also be ordered with a right-hand or left-hand hose configuration.



ITR's standard cabin heater fan comes with loose stainless steel brackets. The fan can be mounted on the floor or on the wall, either flat or on its side.

The thermostat should not be mounted on walls outside of the zone because that could cause false temperature readings. Mount on interior walls and bulkheads, away from windows, heater vents and cabin fan heaters.



## 5.5 Procedure

After choosing the appropriate mounting location and configuration:

- 1** Mount the fan using #10 sheet metal screws or wood screws, see *Figure 5-2: Mounting a Spacesaver Fan*.
- 2** If you are using ducting and a dual air outlet plate for any fan, limit the total length of duct for both outlets to 36" for optimum air output.
- 3** Select the appropriate mounting location for the thermostat, as well as any fan speed switches. You will wire these up to the Zone Control Board in *Section 9 – Installing the Distribution Module*.
- 4** The zone control board can control up to 5 zones. The cabin fan 1 lead (orange) can supply up to a maximum of 10 Amps. The other cabin fan leads 2-5 can supply up to a maximum of 5 Amps each. The total current draw is not to exceed 18 Amps for all cabin fan leads.
- 5** If the system requires higher amperage draws, install a separate relay to power the fans. This relay will use the existing fan circuit as a signal and must be wired to a secondary power source (not the heater's control board). See *Figure 5-3: Installing a Relay for Additional Fan Amperage*.
- 6** To install plumbing lines to the fans, see *Section 7 – Plumbing the System*.

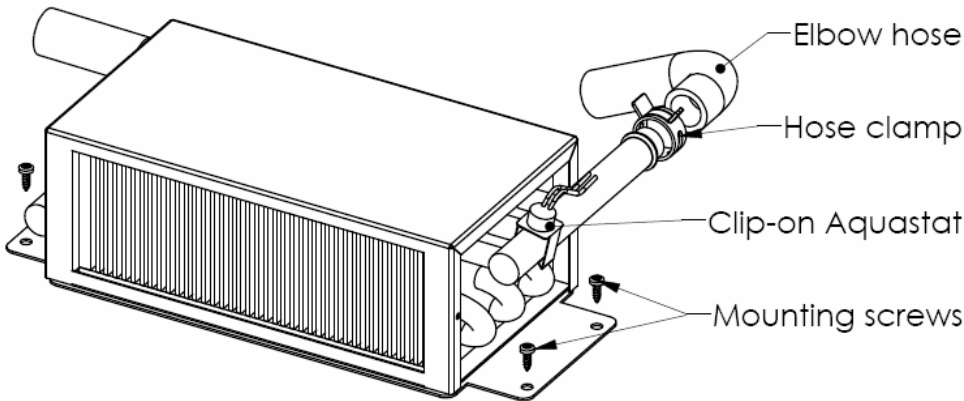

Figure 5-2: Mounting a Spacesaver Fan

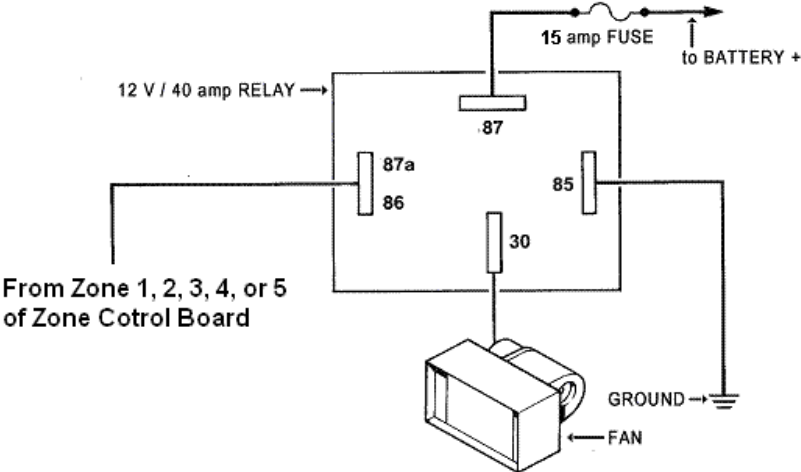

Figure 5-3: Installing a Relay for Additional Fan Amperage

# Wiring the Electrical System



## 6.1 Before You Begin

The Oasis™ Heating Module and its electrical Control Board are pre-wired and have been thoroughly tested together as a unit.

To review the wiring system for the Oasis™ Heating Module, refer to the wiring diagram at the end of this *Section 6, Figure 6-1: System Wiring*.

### ! WARNING

---

All electrical connections and wiring must comply with normally-accepted 12 VDC and 120 VAC wiring practices, local regulations, and ABYC/RVIA standards. Only a qualified electrical installer should complete the wiring. All field wiring is to be in accordance with CSA Standard C22.1, Canadian Electrical Code Part I or the National Electrical Code, ANSI/NFPA 70.

---

## 6.2 12 VDC

The following apply to the 12 VDC connections for the Oasis™ Heating Module:

- There is one paired set of 12 VDC electrical connections on the top right of the Oasis™ Heating Module. They consist of the primary DC positive (red) and negative (black) connection and are 14 gauge stranded copper wires.

### ! WARNING

---

Primary DC power should originate from a dedicated connection on the house battery bank. A 20 amp fuse or breaker must be included close to and inline from the battery to the positive (red) connection on the Oasis™ Heating Module. The primary power wire gauge must be sized to permit no more than a 3% voltage drop from the battery to the Oasis™ Heating Module.

---

- A properly-shielded power system is required for safe, trouble-free operation.

## 6.3 120 VAC

- The Oasis™ Heating Module is equipped with two 1500 watt, 120 VAC immersion elements (other voltages and frequencies are available). The connections for the electrical supply are on the top left side of the Oasis™ Heating Module, under a cover, labeled AC power.
- The power wires for the AC immersion elements are three 14 gauge stranded copper leads that use standard AC color code (black-hot, white-neutral, green-ground). These are to be connected using standard 120 VAC electrical connectors and terminals.
- There are two sets of power wires, one set with black heat shrink (primary) and one set without heat shrink (secondary). Each individual set must be connected to a separate AC circuit breaker. The primary set is connected to the single AC element side of the Oasis™ Heating Module. The secondary set of wires is connected to the other AC element. If only one AC circuit breaker is available, you must connect to the primary wire set only. Once the connections are completed, the wires are to be inserted back into their compartment and the cover secured.
- The ground wire (green) is shared between the two connections.

### NOTICE

---

Do not operate the electric immersion elements until water is added to the Oasis™ Heating Module and Distribution Module, and all trapped air has been removed.

---

## 6.4 Remote Operating Panel Cable

- One connection on top of the Oasis™ Heating Module is a multi-wire, sheathed cable with a 9 pin connector. This connects to a matching connector on a short adapter cable. The other side of the cable has a 10 pin connector that connects to a 25' remote cord. This remote cord then plugs directly into the Remote Operating Panel. Refer to *Figure 6-1: System Wiring*.
- If the Distribution Module is used, refer to *Section 9, Installing the Distribution Module*.



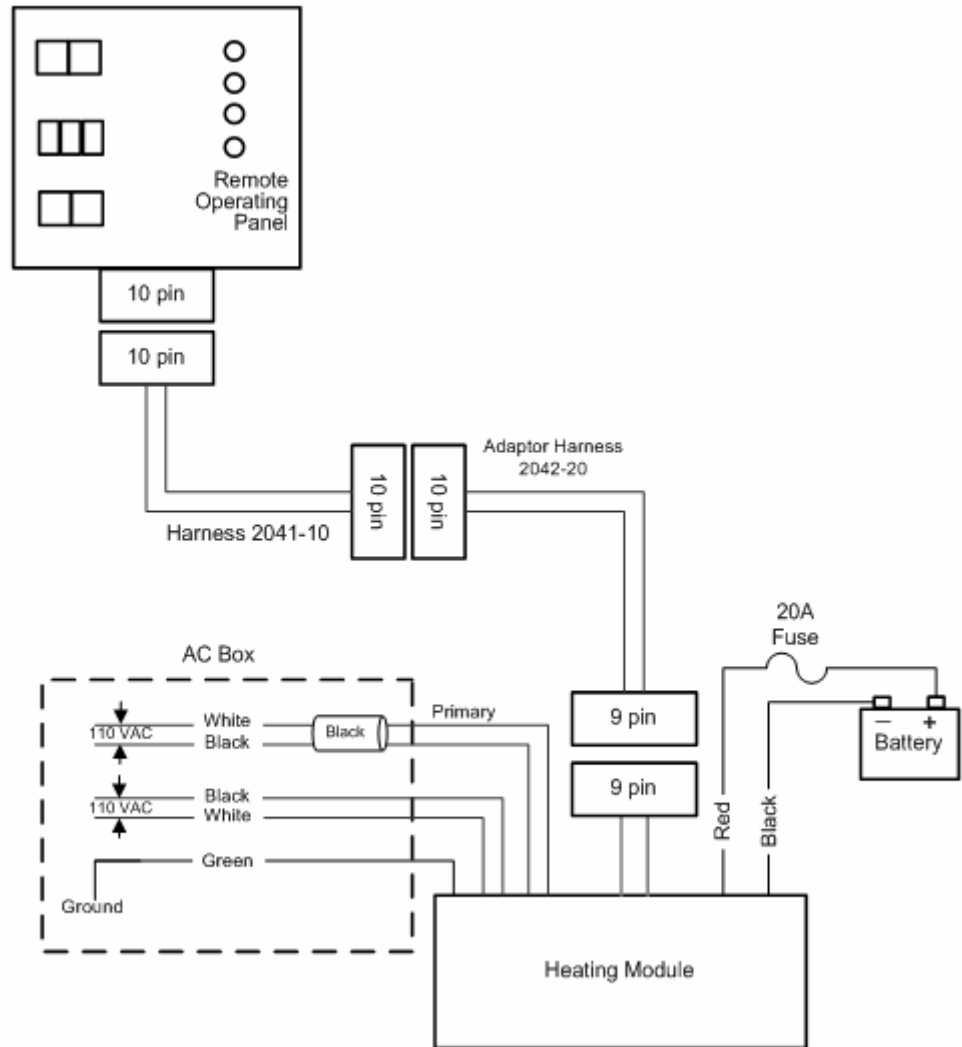

Figure 6-1 System wiring

## 6.5 Main Electronic Control Board

---

The main electronic Control Board is mounted onboard the Oasis™ Heating Module itself. It has no user adjustable components.

---

## 6.6 Distribution Module Zone Control Board (optional)

- The Distribution Module is controlled by a separate Zone Control Board. See *Section 9, Installing the Distribution Module*.

**NOTICE**



## 6.7 What NOT to Do

---

### NOTICE

**Never** shut off the Oasis™ Heating Module power via an inline battery or master switch while the system is running. Never disconnect the battery when the Oasis™ Heating Module is running, and never disconnect the battery while the inverter is charging. Do not wire the Oasis™ Heating Module through a disconnect that is used as a normal shut-down of the DC system.

Doing either will severely damage the Oasis™ Heating Module because it fails to automatically purge the combustion chamber. Such damage is detectable upon inspection and will *not* be covered under warranty. Always shut the system off using the normal system controls, after it has completed its purge and cooled down the combustion chamber.

---

# Plumbing the System

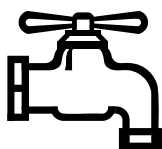

## 7.1 Before You Begin

For efficient and safe operation of the Oasis™ Heating Module, follow all recommendations for properly installing the plumbing system. Any deviations from these must be approved in advance by ITR.

### ! DANGER

The Oasis™ Heating Module when attached to the Distribution Module (optional) must use the following:

Use only a non-toxic, propylene glycol based coolant with additives generally recognized as safe "GRAS" by the FDA in the coolant side of the Distribution Module (including engine loop).

When heat is called for, the distribution pump in the Distribution Module (optional) sends heated fluid out to the cabin fans.

For an efficient Oasis™ Heating Module operation, you must:

- Minimize heat loss from the Heating Module and hoses.
- Follow the flow directions for the fluids in the Heating Module. *Figure 9-3: Plumbing for Five Zones Using the Distribution Module in Section 9, Installing the Distribution Module* shows a typical plumbing layout for circulating coolant from the Oasis™ Heating Module, then to the Distribution Module, and finally to the cabin fans.

## 7.2 Plumbing Installation

The plumbing installation should consider the following:

- The Oasis™ Heating Module has a filler neck located on the top of the unit and is equipped with a seven (7) pound radiator cap.

Ensure a four (4) quart minimum overflow bottle is attached to the filler neck.

- The return and supply coolant plumbing connections are on the top of the Oasis™ Heating Module and are 1/2" male NPT fittings. The return coolant input to the Oasis™ Heating Module is a connection labeled "Inlet" and the supply coolant output from the Oasis™ Heating Module is a connection labeled "Outlet". Ensure proper direction of flow. Refer to Figure 7-1: *Heating Module* for the location of the fittings.
- Two 1/2" NPT pipe to 3/4" hose barb fittings (not supplied) must be fitted into the Oasis™ Heating Module connections and tightened to a leak free condition using an appropriate thread sealant.
- Hose and/or tubing used to connect to the Oasis™ Heating Module or Distribution Module input and output connections must be heavy duty heater hose, minimum 3/4" I.D, or 5/8" PEX.

## NOTICE

---

All fittings on the Oasis™ Heating Module require two wrenches when tightening. One wrench must be placed on the tank fitting and held in place to prevent this fitting from being overstressed. The other wrench can be used to tighten the matching half of the fitting onto it. Failure to follow this procedure will damage the Oasis™ Heating Module and the fittings.

---

## ! DANGER

---

Do not operate the Oasis™ Heating Module until a proper water/anti-freeze solution has been added to the Oasis™ Heating Module and the heating system and all trapped air has been bled. An inadequate mixture may cause system circulation problems and potential Oasis™ Heating Module damage and/or personal injury. Use only a non-toxic, propylene glycol based coolant with additives recognized as safe "GRAS" by the FDA. Refer to the anti-freeze manufacturer recommendations for instructions for your application.

---

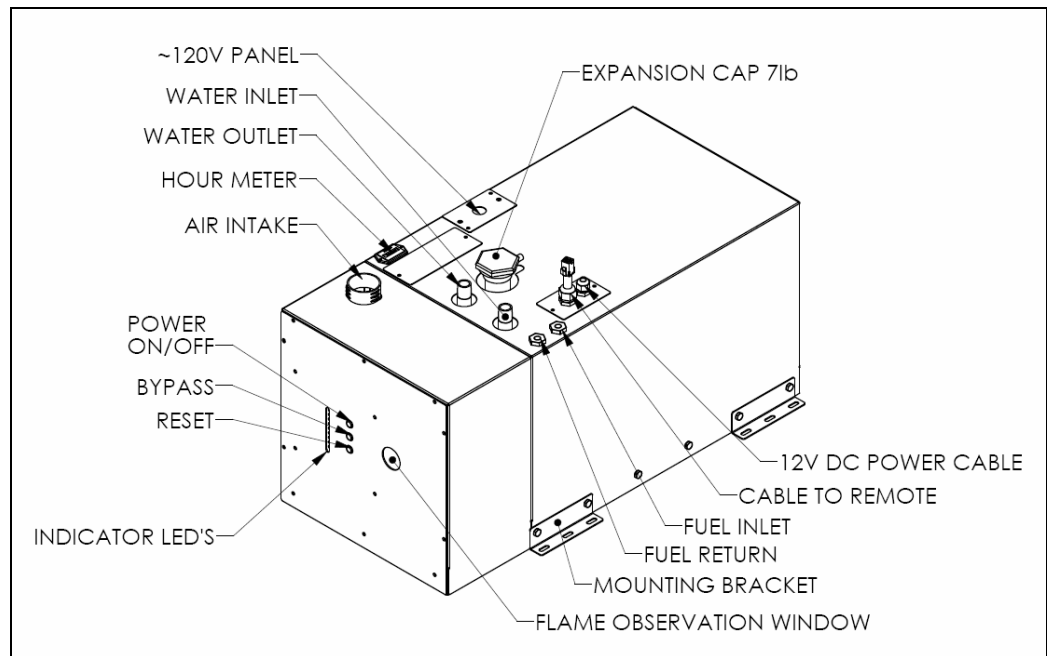

**Figure 7-1 Heating Module**

**NOTICE**

All fittings, hose and/or tubing involving the domestic water component of the Distribution Module, must be approved for use with domestic water and rated for the domestic water system pressure

- All plumbing lines must be run and secured so as to prevent damage, chafing and kinking
- Ensure that the coolant flow is adequate through the Oasis™ Heating Module and the system. An indication of inadequate flow is, when the Oasis™ Heating Module is running and up to normal operating temperature, the difference between the inlet and outlet coolant temperature to the Oasis™ Heating Module is less than 20F.
- The Distribution Module contains three distribution pumps and one heat exchanger and is pre-wired and pre-plumbed for ease of installation.
- The Heating and Distribution Modules should be filled and flushed prior to operation to remove any foreign debris.

- Use heavy-duty heater hose or PEX tubing. Slip-on foam insulation coverings may be used over the hose fittings to reduce heat loss. Secure all hose connections with spring clamps.
- Air vents for the fluid circulation system are not supplied, but may be optionally installed to help bleed air from the system.



## NOTICE

### 7.3 What NOT to Do

The Oasis™ Heating Module's circulating water pump is one of the most critical parts of the system. **Never** let the pump run dry or you will damage the impeller. This is not covered under warranty.

**Don't** use low-quality heater hose.

**Don't** let the hose come into contact with solvents, which may cause it to soften and swell. If there is any risk that solvents may contact the hose, insert it into PVC plastic tubing for protection.



### 7.4 Installation Procedure

To install and connect the Oasis™ Heating Module and heater hose:

- 1 The supply and return coolant connections are on top of the Oasis™ Heating Module and are 1/2" male NPT fittings. The return coolant input to the Oasis™ Heating Module is labeled "Inlet" and the supply coolant output from the Oasis™ Heating Module is labeled "Outlet". Ensure proper direction of flow.
- 2 Two male 1/2" NPT x 3/4" hose barbs (not supplied) must be fitted into the supply and return fittings and tightened to a leak free condition.

**If the Distribution Module is to be used with the Oasis™ Heating Module**, refer to *Section 9, Installing the Distribution Module*.

- 3 If the Distribution Module is not utilized**, connect the cabin fan heater supply lines to the supply coolant "Outlet" from the Oasis™ Heating Module. Ensure there are no kinks or sharp bends that might restrict the fluid flow. See *Figure 7-2: Three Approved Methods of Installing Heater Hose (Consult ITR for Alternative Methods and Products)* for methods of attaching the heater hose.

Connect the cabin fan heater return lines to the return coolant "Inlet" on the Oasis™ Heating Module. Ensure there are no kinks or sharp bends that might restrict the fluid flow.

- 4** Fill the Oasis™ Heating Module through the filler neck with the recommended propylene glycol/water anti-freeze solution and bleed all trapped air.

Do not operate the Oasis™ Heating Module until the proper water/anti-freeze solution has been added to the Oasis™ Heating Module and the heating system and all trapped air has been bled. An inadequate mixture may cause system circulation problems and potential Oasis™ Heating Module damage and/or personal injury.

Use only a non-toxic, propylene glycol based coolant with additives recognized as safe "GRAS" by the FDA. Refer to the anti-freeze manufacturer recommendations for instructions for your application.

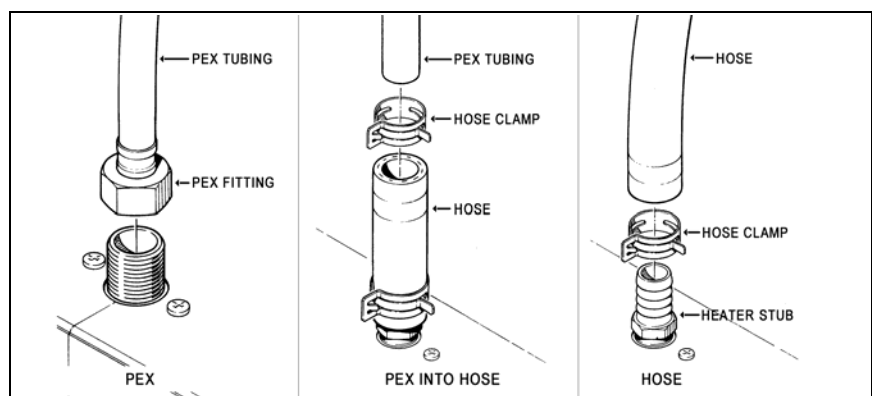

**Figure 7-2: Three Approved Methods of Installing Heater Hose (consult ITR for alternative methods and products)**





# Operating the Oasis™ Heating Module

This section describes the features, operation and maintenance of your new Oasis™ Heating Module. READ THESE INSTRUCTIONS AND SAVE FOR REFERENCE.

## 8.1 Features of Your Oasis™ Heating Module

The Oasis™ Heating Module uses a diesel burner (12 VDC) controlled by a multi-functional electronic controller as the primary source of heating coolant fluid (anti-freeze and water). Two 1500 Watt, 120 VAC immersion elements are used as secondary heat sources. The Oasis™ Heating Module heats the coolant fluid to provide a source of heat for all hydronic space heating needs. When used with the Distribution Module and its integral distribution pumps, the Oasis™ Heating Module has the ability to circulate the coolant fluid to all space heating areas. It can also provide a supply of domestic hot water using the integral heat exchanger in the Distribution Module.

Other features of the Heating Module include:

- A high-temperature, stainless steel burner and stainless steel jacket.
- 8.2 US gallon welded insulated stainless steel coolant tank that minimizes heat loss and optimizes heat recovery.
- Low coolant level switch on the tank.
- Easy to install, completely modular and field serviceable with Heating Module hookups and connections easily accessible from the front and top of the Oasis™ Heating Module.
- Quiet operation and low power consumption.

- Low pressure fuel system with built-in fuel pump.
- Fuel efficient burner capable of burning a wide variety of diesel-based fuels.
- Exhaust has minimal smoke and smell.
- Fan assisted sealed combustion is designed to use outside combustion air.
- Simple, low amperage draw ignition.
- Electronically-controlled system with:
  - Automatic safety shutdown.
  - Manual-reset aquastats for safety overheat protection.
  - LED indicators on the Control Panel for diagnostics.
  - Patented, proprietary Flame Sensor.
- Heating Module Remote Operating Panel with ON/OFF switch for the diesel burner, AC elements, and engine heat.
- Heating Module Control Panel with buttons for Power, Bypass, Reset, and indicator LED's for operational and diagnostic information;

**Available with the Optional Distribution Module:**

- Three distribution pumps, one heat exchanger for heating multiple zones, engine heat function, and also producing domestic hot water (mixing valve included). Also includes filling valves for easy filling/purging.
- Zone Control Board for controlling up to five space heating zones.

## 8.2 Your Heating Module Model

**NOTICE**

---

As the user, you must be fully aware of the controls and operating features particular to your model of The Oasis™ Heating Module. This is essential for the proper functioning and life of your Oasis™ Heating Module as well as protecting your warranty.

---

Your model can be identified by locating the serial number label on the outside case of the Oasis™ Heating Module. The serial

number identifies the model type through the first series of letters and numbers.

The two types of Oasis™ Heating Modules are:

CH50M – Oasis™ Heating Module 8 Gallon

CH50V – Oasis™ Heating Module 16 Gallon

### 8.3 Operating Instructions for the Oasis™ Heating Module

#### NOTICE

The Oasis™ Heating Module must be installed and connections made in accordance with the recommendations in the Installation and Operating Manual prior to operating the module.

- The Oasis™ Heating Module, *Figure 8-1: Oasis™ Heating Module*, heats the coolant to a preset temperature and will automatically cycle to maintain the temperature.

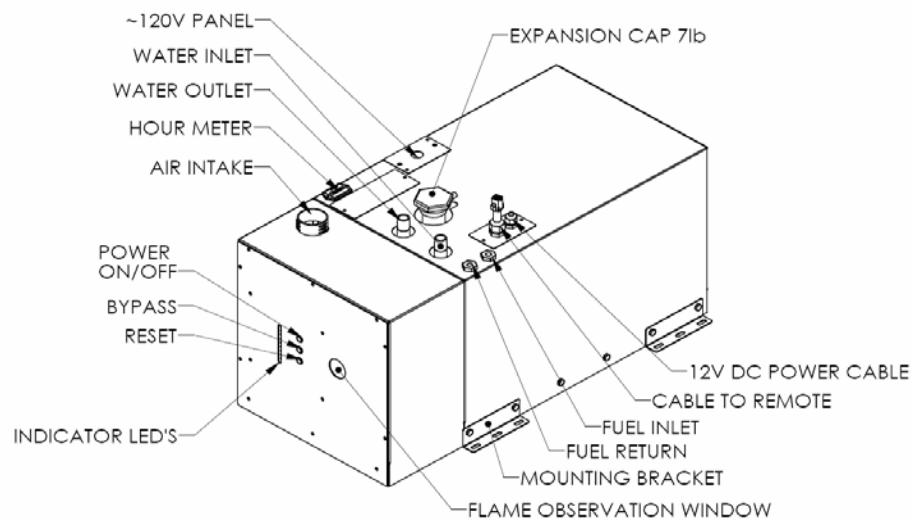
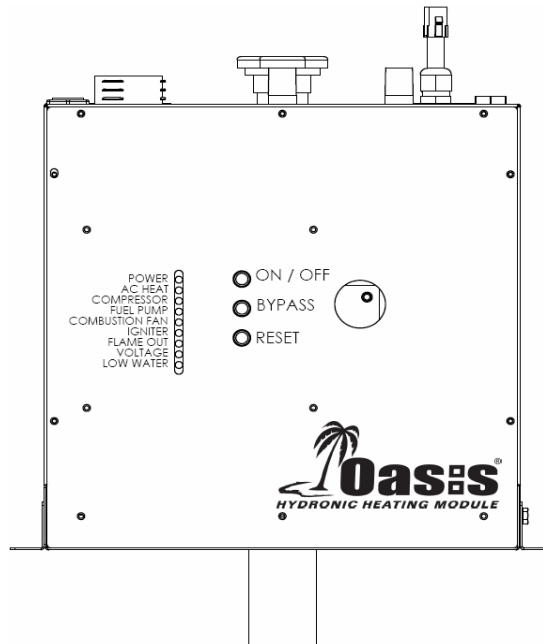

Figure 8-1 Oasis™ Heating Module

## 8.4 Turning the Power to the Oasis™ Heating Module ON

- The Oasis™ Heating Module's main Control Panel, *Figure 8-2: Heating Module Main Control Panel*, located on the front of the module contains three push buttons: ON/OFF power, Bypass, and Reset. The power switch must be pushed ON (power LED will turn ON) to turn the DC electrical power to the main control board and module ON and is required to be left ON during any period where heat is requested.
- When the Oasis™ Heating Module is shut down for any extended period or the season, it is recommended that the power switch be turned OFF.



**Figure 8-2 Heating Module Main Control Panel**

### NOTICE

Do not operate the Oasis™ Heating Module or Distribution Module (if installed) until a suitable water/anti-freeze solution is in the modules and all trapped air has been bled or removed.

### ! DANGER

Use only a non-toxic propylene glycol based coolant with additives generally recognized as safe "GRAS" by the FDA in the Oasis™ Heating Module and Distribution Module.

## 8.5 Activating the Burner (Primary) and AC Heat (Secondary) from the Remote Operating Panel

### **Activating the Burner (Primary Heat Source)**

- The burner switch on the Remote Operating Panel controls the ON/OFF of the diesel burner (primary heat source). When the burner switch is turned ON, the diesel portion of the Oasis™ Heating Module will turn ON after ten seconds. The Burner LED will turn ON when the diesel burner has been activated. The burner will continue to operate until the coolant in the Oasis™ Heating Module reaches the set operating temperature range. At this point, the diesel burner will turn OFF. If the Oasis™ Heating Module coolant should cool down below this temperature range, the burner will again commence firing and will continue until either the burner switch on the remote panel is turned OFF or the temperature range is again achieved. If the burner switch on the remote panel is turned OFF, the burner stops and the Oasis™ Heating Module enters a two minute cool down stage prior to completely shutting down.

### **Activating the AC Immersion Element(s) (Secondary Heat Source)**

- Place the AC power switch on the Remote Operating Panel to either the one element or two element position. The AC Heat (green) LED will turn ON indicating the AC element(s) are energized and the coolant is being electrically heated. They will continue to operate until the coolant in the Oasis™ Heating Module reaches the set operating temperature range. At this point, the elements will turn OFF. If the Oasis™ Heating Module coolant should cool down below this temperature range, the AC elements will again be energized and will continue until either the AC switch on the remote panel is placed in the OFF position or the temperature range is again achieved. If the AC element switch on the remote panel is turned OFF, the AC elements are de-energized and the AC Heat (green) LED turns OFF.

### **Activating the Burner and AC immersion Element(s) Jointly**

- Turn the burner switch ON and place the AC power switch on the Remote Operating Panel to either the one element or two element position. The Burner and AC Heat (green) LED's will turn ON indicating the diesel burner and AC element(s) have been selected.

## 8.6 Activating the Cabin Fan Heaters through the Thermostats

### **(Distribution Module Equipped Systems Only) (Burner or AC Heat or Engine Heat Source Available)**

- Any thermostat connected to the Distribution Module's Zone Control Board and calling for heat will cause the cabin fan controlled by that thermostat to be enabled. The ITR cabin fan has a built-in aquastat that prevents the cabin fan from blowing cold air. Once the room temperature has reached the temperature called for by the thermostat the cabin fan will turn off.

## 8.7 Activating the Domestic Hot Water

### **(Oasis™ Heating Module and Distribution Module used in Tandem) (Burner or AC Heat On)**

- As long as heat is available in the Oasis™ Heating Module, the Distribution Module (Optional) will respond to a call for domestic hot water. Ensure that a heat source has been selected (i.e. Burner, AC, Engine). The production of the domestic hot water is **continuous** on the Burner operation and **limited** when using AC or Engine.

#### **NOTICE**

---

The domestic water pump is not a part of, nor controlled by the Distribution Module or The Oasis™ Heating Module.

---

## 8.8 Activating Engine Heat & Pre-heat

### **(Oasis™ Heating Module and Distribution Module used in Tandem) (Burner or AC Heat On)**

#### **Pre-heating the Engine**

- Turn the engine preheat switch on the Remote Operating Panel to the ON position with the burner or AC switch on. The engine preheat pump and coolant pump will be activated once the Oasis™ Heating Module is in its set operating temperature range. The engine will start to be preheated by the Oasis™ Heating Module.
- Note: An engine preheat pump does not come supplied with the Distribution Module. The power and ground for the pump is available from the Distribution Module.

### Engine Heat Used for Domestic Water or Space Heating

- Start the vehicle engine and let it come up to the normal operating temperature. Turn the burner switch on the Remote Operating Panel to the ON position. The Oasis™ Heating Module will come up to the set operating temperature range and will cycle OFF. The heat from the vehicle engine will be transferred from the engine to the domestic water and space heating loop.

## 8.9 Functions of the Remote Operating Panel

- The Oasis Heating Module's Remote Operating Panel, *Figure 8-3: Remote Operating Panel*, contains one ON/OFF burner switch, one triple position AC element switch, one ON/OFF engine heat switch to control the optional engine pre-heat pumps, and four LED's indicating Burner activation, AC element activation (CH50 used in tandem with Distribution Module), module fault, and zone fault.

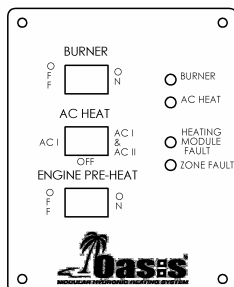

Figure 8-3 Remote Operating Panel

### **Burner Switch (Primary Heat Source)**

- The burner switch on the remote panel controls the ON/OFF of the diesel burner. The Burner LED will turn on when the diesel burner has been activated.

### **AC Element Switch (Secondary Heat Source) (CH50 and DM8 used in Tandem)**

- The triple position AC element switch controls the activation of a single 120 VAC immersion element only, dual 120 VAC immersion elements jointly, or both elements off. The AC heat LED will turn ON to indicate when the element(s) have been activated.

### **Engine Pre-Heat Switch (CH Models with this Option Only)**

#### **Preheating the Engine**

- The engine pre-heat switch (optional) controls the ON/OFF of the engine pre-heat pump (not included). However, the engine pre-heat pump (not included) will not function unless the coolant in the Oasis™ Heating Module has achieved a preset temperature.

#### **Burner LED (Green)**

- When ON, indicates the diesel burner has been activated.

#### **AC Heat LED (Green)**

- When ON, indicates the 120 VAC immersion element(s) are activated.

#### **Module Fault LED (Red)**

- When ON, indicates the Oasis™ Heating Module has faulted. The specific fault can be identified by examining the Oasis™ Heating Module Control Panel located on the front of the Oasis™ Heating Module. There are indicator LED's on the panel that are used for diagnostics. Refer to the description of the Oasis™ Heating Module Control Panel for further details.

#### **Zone Fault LED (Red) (Functional with Distribution Module Equipped Models Only )**



- When ON, indicates the space heating zone(s) has faulted. The specific fault can be identified by examining the Distribution Module Zone Control Panel (optional) located beside the Oasis™ Heating Module. There are indicator LED's on the panel that indicate the problem. Refer to the description of the Distribution Module Zone Control Panel for further details.

### 8.10 Functions of the Heating Module Control Panel

- The Oasis™ Heating Module's Control Panel, Figure 8-2: Heating Module Main Control Panel, contains three push buttons: ON/OFF power, Bypass, and Reset. In addition, it contains nine LED's indicating Power, AC Heat, Compressor, Fuel Pump, Combustion Fan, Igniter, Flame Out, Voltage and Low Water.

#### **Power Button**

- The power button turns ON/OFF the power to the control board. The Power LED (green) turns ON when the power to the control board is ON.

#### **Bypass Button**

- The bypass button is for **authorized service personnel only**.

#### **Reset Button**

- The reset button when pressed resets the control board.

#### **Power LED (Green)**

- The power LED (green) turns ON when the power to the control board is ON. The LED flashes when the Oasis™ Heating Module is in Bypass mode.

#### **AC Heat LED (Green)**

- The AC Heat LED (Green) turns ON when a single or dual AC immersion element(s) have been activated.

### **Compressor, Fuel Pump, Combustion Fan, Igniter (Green)**

- The compressor, fuel pump, combustion fan, and igniter LED's (Green) turn ON when the component is ON, and will flash if the component is electrically open or shorted.

### **Flame Out (Red)**

- The Flame Out LED (Red) turns ON when a flame fault has been detected.

### **Voltage Fault (Red)**

- The voltage fault LED (Red) turns ON when a voltage fault has been detected.

### **Low Water (Red)**

- The Low Water LED (red) turns ON when a low coolant level in the Oasis™ Heating Module has been detected.

## **8.11 Functions of the Distribution Module (Optional) Zone Control Panel**

- The Distribution Module Zone Control Panel, *Figure 8-4: Zone Control Panel*, contains seven green LED's for *Power, Zone 1, 2, 3, 4 and 5 Thermostat(s), and Domestic Water*.
- It also contains nine matched pairings of red/green LED's for *Zone 1, 2, 3, 4 and 5 Fan(s), Summer Loop, Heat Loop 1, Heat Loop 2, and Engine Pre-heat Pump*.

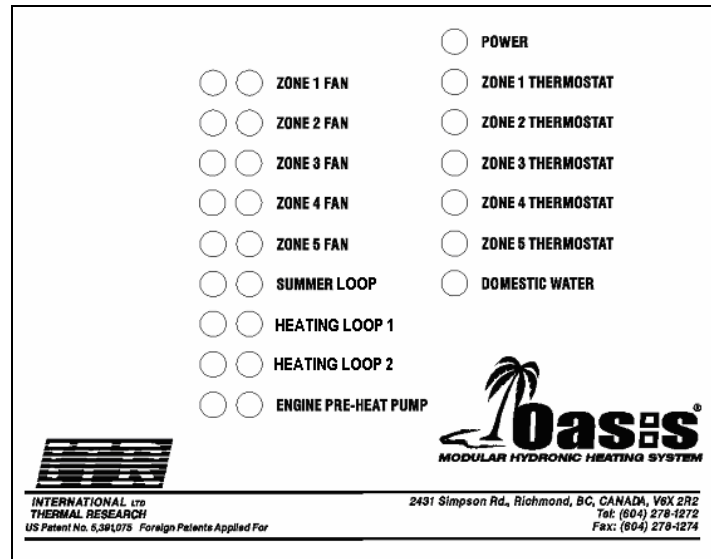

Figure 8-4: Zone Control Panel

### Power LED (Green)

- The power LED turns ON when the power to the Distribution Module Zone Control Board is ON.

### Zone 1, 2, 3, 4, 5 Thermostat LED's (Green)

- The Zone # LED turns ON when the thermostat in the zone is calling for heat.

### Domestic Water LED (Green)

- The domestic water LED turns ON when there is a call for domestic water heat.

### Zone 1, 2, 3, 4, 5 Fans, Summer Loop, Heat Loop 1, Heat Loop 2, Engine Pre-heat Pump Paired LED's (Red/Green)

- The nine paired LED's indicates the functionality of the devices. The green LED will turn ON when the device is operating normally. The red LED turns ON if a fuse has been blown.

## 8.12 Maintenance

**Customer Monthly Maintenance:** Check the following and correct as required:

- Coolant hoses and fittings for leaks and integrity.
- Check coolant level in the overflow bottle (3/4 full when hot). **Fill only when the system is COLD and in small quantities only to prevent overfilling.**
- Exhaust fittings, connections, tubes for leaks, and integrity.
- Exhaust and air-intake checked for no obstructions.
- Fuel lines, fittings for leaks and integrity.
- External fuel filter for clogging.

**Annual Service Requirements:** Perform the following:

- **Prior to operation for the season, a factory service tune-up of the modular system should be performed by trained service personnel.** Only personnel familiar with the equipment modules should perform the service tune-up. It is recommended that the dealer be contacted for this service or if not available, contact ITR for information on service resources.
- As a general guide, the regular maintenance items such as the igniter, fuel filters (internal and external), and air filter (internal) should be replaced as opposed to inspected and cleaned. Their performance may be deteriorating and/or their remaining service life ending without any apparent visual signs or operating symptoms.
- The major components such as the air compressor, fuel pump, fuel nozzle, and combustion air fan should be examined for wear and should be replaced by the service technician as required.
- The combustion tube should be inspected by the service technician for wear and replaced if necessary. To access the combustion tube, the front panel of the Oasis™ must be removed along with the burner box cover. The fuel block must then be removed from its mounting position.

Finally, the burner and counter-flow tube must be taken out by removing the nuts holding the burner box in position. If the tube is satisfactory, a thorough cleaning of the tube and burner chamber should be performed by blowing out and vacuuming any ash and carbon buildup. Any build up on the surface of the burner chamber will cause the heater to lose efficiency.

- Regular inspection and maintenance is the only way to ensure safe, reliable and efficient operation of your heating system.

### 8.13 Protecting the Heating Module and the Optional Distribution Module

#### NOTICE

---

Protect the Oasis™ Heating Module and Distribution Module (Optional) from temperature extremes and any dusty, dirty, corrosive environment.

---

#### ! DANGER

---

Protect the module(s) and the system from cold temperatures and corrosion by using a proper mixture of anti-freeze and water. Use only a non-toxic propylene glycol based coolant with additives generally recognized as safe "GRAS" by the FDA in the Oasis™ Heating Module and Distribution Module (Optional). Read and follow the anti-freeze manufacturer's instructions for the type of anti-freeze and mixture recommended for your application.

---

#### NOTICE

---

Note that any domestic water in the Distribution Module (Optional) will freeze in cold temperatures and will damage the internal parts. The Distribution Module and all associated components must be completely drained and emptied of any domestic water before freezing temperatures are encountered.

---

### 8.14 General Troubleshooting

***Ensure that your heating module has both sufficient battery voltage and ground, and coolant level as the module is designed not to allow operation if either are incorrect (indicated by lit Voltage LED or Low Water LED on the Oasis™ Heating Module Control Panel) .***

#### **Burner Does Not Start Up**

- Oasis™ Heating Module connected to 12 VDC power?
- Power button on Oasis™ Heating Module Control Panel pushed ON? Power LED lit on Oasis™ Heating Module Control Panel?
- Burner switch on Remote Operating Panel ON? Burner LED lit on Remote Operating Panel?
- Main fuse or circuit breaker blown or tripped?

### **AC immersion elements do not activate**

- Module connected to 120 VAC power?
- AC switch on Remote Operating Panel placed in the one or two element position? AC Heat LED lit on Remote Operating Panel?
- AC immersion elements circuit breakers tripped?

### **Burner Starts but Flame Faults**

- Fuel supply present and adequate?
- Air-intake or exhaust not blocked or obstructed?
- Air in fuel line (white smoke from exhaust or popping sound from exhaust)?
- Fuel filter (external) dirty?
- Restrict the fuel return line with needle valve or pinch off completely.

### **Burner Starts but Zone Faults**

- Power LED on Distribution Module Zone Control Panel glowing green?
- Component matched LED pairings all glowing green on the Distribution Module Zone Control Panel?

# Installing the Distribution Module, DM12

Thank you for purchasing the Distribution Module, DM12.

This section describes its installation.

## 9.1 Installing your Distribution Module

### Equipment, Tools and Skills

#### NOTICE

---

As the Installer, you must be qualified and authorized to do the installation which requires mechanical and electrical knowledge.

**The module is to be installed in accordance with the standards and regulations of authorities having jurisdiction.** Proper workmanship is essential to the proper function and life of your module as well as protecting your warranty.

---

## 9.2 Selecting the Module Location

The installation should consider the following:

- Mounting location must be able to support double the gross weight of the Distribution Module (i.e. 33 lbs. x 2 = 66 lbs./13 KG x 2 = 26 KG) and must be of a non-combustible and non absorptive surface.
- The module must be mounted in an area that provides unrestricted access to the front panel (minimum of 6" top clearance) with 3" clearance to all other module surfaces.
- Module is 11"H x 14"W x 6.5" D. (27.9cm x 35.5cm x 15.2cm). See Figure 9-1: Distribution Module, DM12.

- Module must be mounted using four, 1/4" through bolts using 1" diameter fender washers, lock washers and nuts. The module must be mounted in the position as shown against a wall or on the floor.



Figure 9-1: Distribution Module, DM12

### 9.3 Selecting the Distribution Module Zone Box Location

- Mount the Distribution Module Zone Box (containing the Zone Control Board) vertically, close to the Distribution Module. Allow sufficient room to access the internal fuses as well as to view the display LED's on the board itself.
- Mount the bracket against a wall using 2 flat head screws. The distribution module zone box will then click onto the bracket.

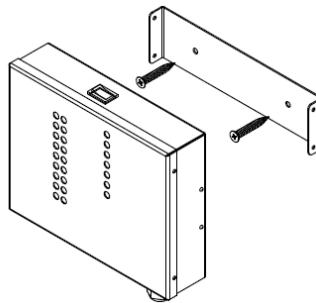

Figure 9-2: Distribution Module Zone Box



- The Distribution Module is connected to the Distribution Module Zone Control Board through the electrical connections located at the bottom of the Zone Control Board box. The distance apart is dictated by the length of the 9 pin connector cord used.

## 9.4 Plumbing Installation

The plumbing installation should consider the following:

- The Distribution Module, see Figure 9-3: *Distribution Module Fittings Location*. See the illustration for the location of the fittings.

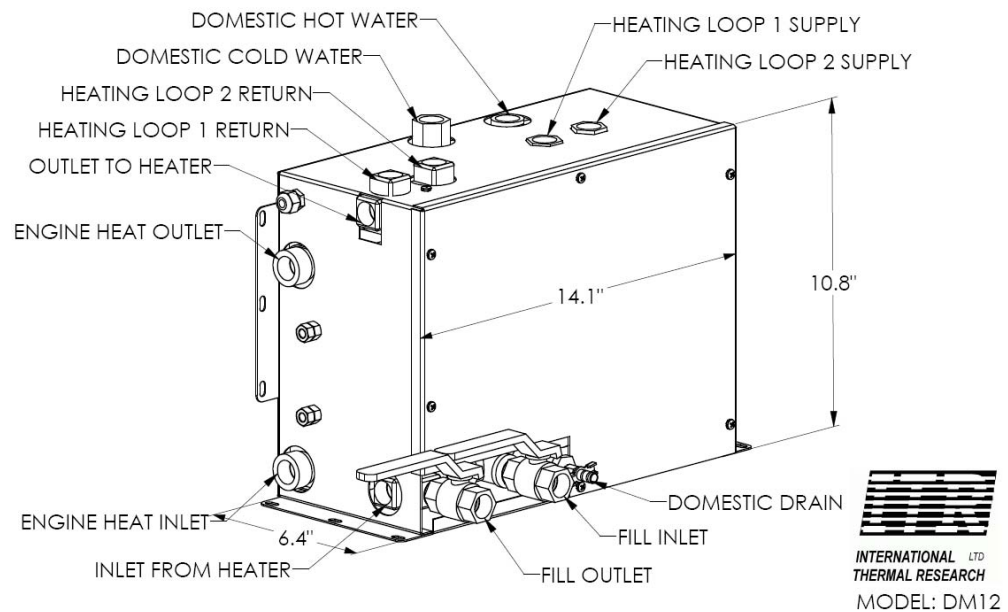

**Figure 9-3: Distribution Module Fittings Location.**

### NOTICE

All fittings on the Oasis™ Distribution Module require two wrenches when tightening. One wrench must be placed on the module fitting and held in place to prevent this fitting from being overstressed. The other wrench can be used to tighten the matching half of the fitting onto it. Failure to follow this procedure will damage the Oasis™ Distribution Module, and the fittings.

- The Domestic water connections are located on top of the module. The Cold water supply can be connected using a ½" NPT fitting. The maximum water supply pressure to the module is 150 PSI (10 bar). The Hot water Outlet temperature is regulated by an internal mixing valve factory set at 120F (49°C). If needed this valve can be adjusted in a range from 100F (38°C) to a maximum of 145F (63°C). For more details about adjusting the temperature see chapter 9.9. A domestic water drain is provided for winterizing purposes. This will prevent damage to the internal heat exchanger due to freezing water. See *Figure 9-4: Domestic Hot water system plumbing.*

**WARNING**

All fittings, hose, tube and fitting sealant involving the domestic water must be food safe and approved for use with domestic water and rated for the domestic water system pressure.

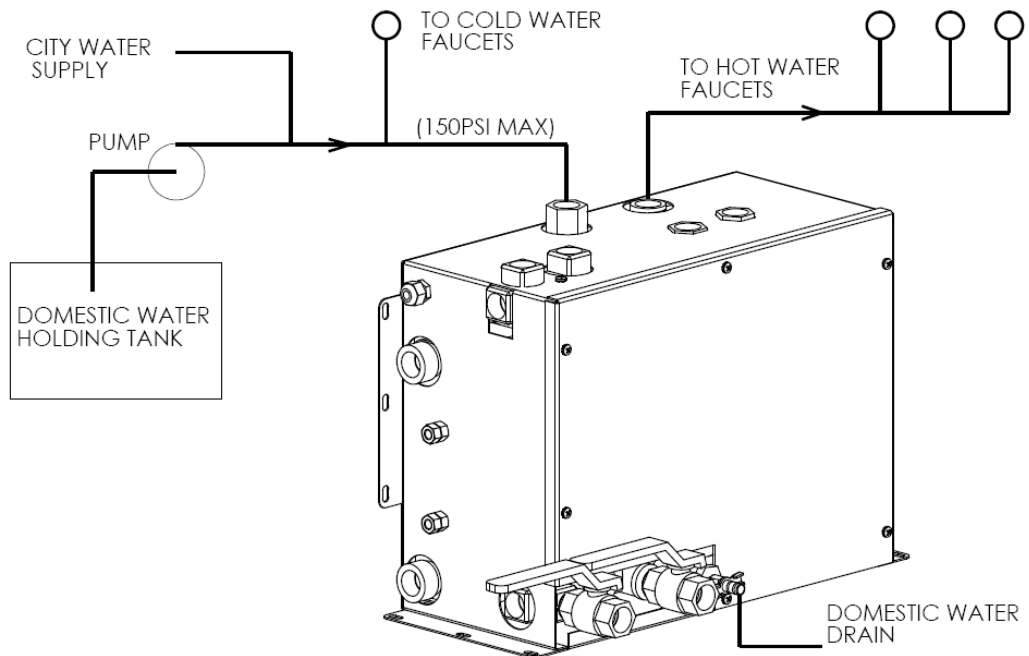

**Figure 9-4 Domestic Hot Water System Plumbing.**

- The engine heat/pre-heat connections are located on the side of the distribution module. Hot coolant from the engine enters the module at the "engine heat inlet". The "engine heat outlet" returns the coolant back to the engine supply. When the pre-heat function is installed an additional pump is connected between the "engine heat outlet" and the engine

supply. The module contains a red and black wire to connect this pump. The pre-heat switch on the remote control panel will activate this pump. See *Figure 9-5: Engine heat/pre-heat system plumbing*.

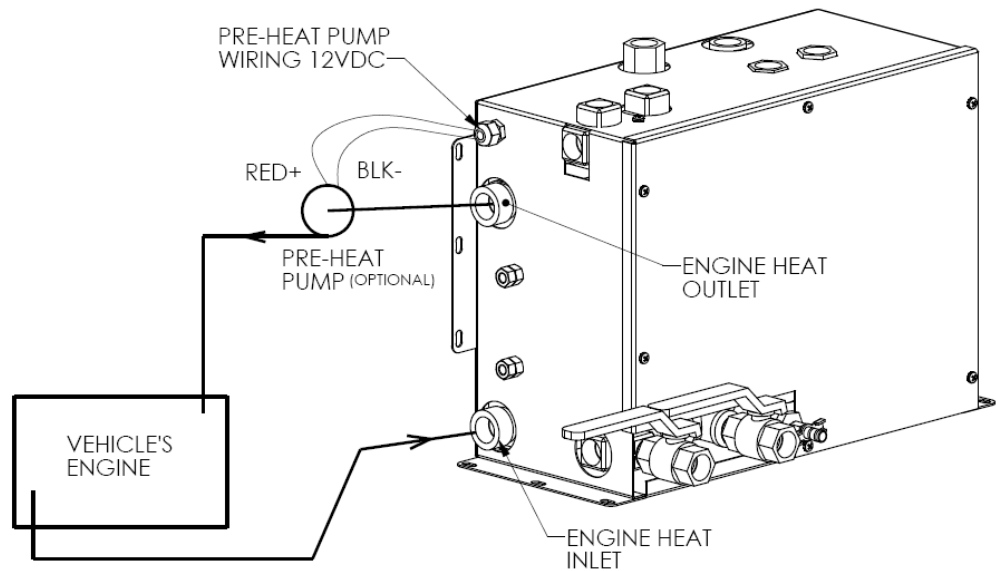

**Figure 9-5 Engine Heat / Pre-heat System Plumbing.**

- The pre-heat pump wires are capped off to prevent accidental shorting. The pre-heat switch on the remote will turn on power to the wires.
- The Distribution module contains two connections on the side panel to connect to the Oasis™ Heating Module. The “Inlet from Heater” is connected to the hot coolant supply outlet on the Oasis™ Heating Module. The “Outlet to Heater” is connected to the cold coolant return inlet on the Oasis™ Heating Module. It is recommended to use minimal 3/4” ID hose for this connection. See *Figure 9-6: Connecting to the OASIS heating module*.

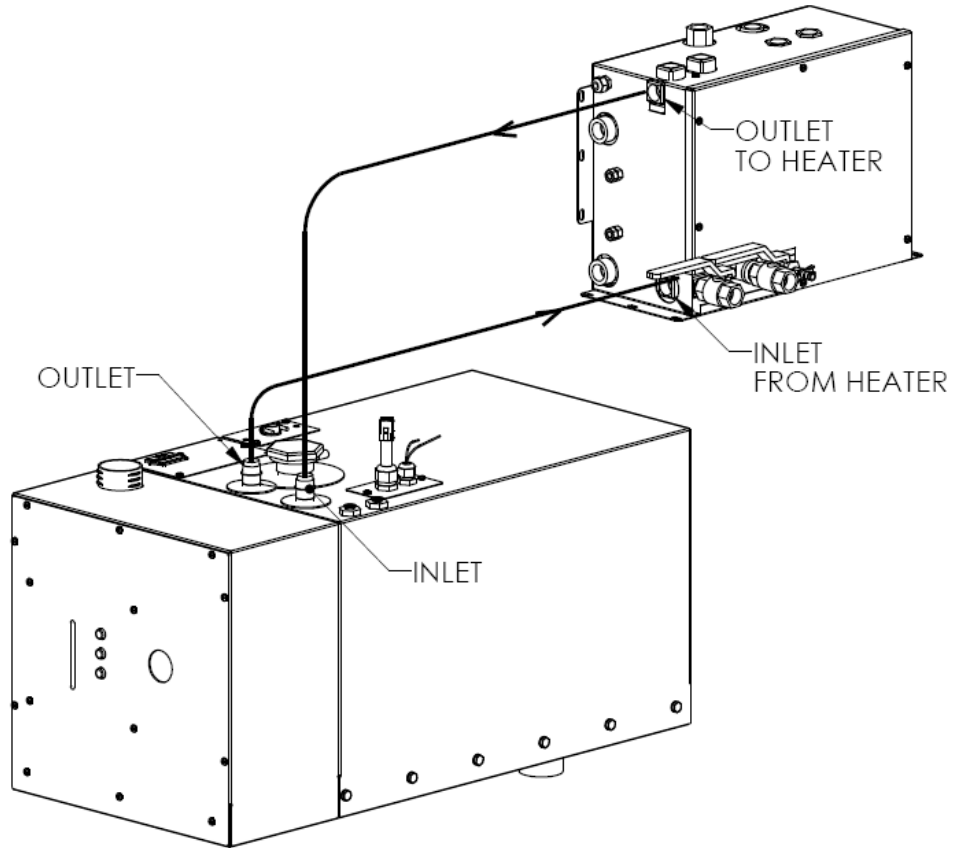

**Figure 9-6: Connecting to the OASIS Heating Module**

- The Distribution module has the capability to supply heat for two separate heating loops labeled “Heating loop 1 supply” and “Heating loop 2 supply”. Each loop can contain several fans connected in series. The control board can regulate up to 5 zones. Zones 1 and 2 control the fans in heating loop 1 and Zones 3, 4 and 5 control fans in heating loop 2. See *Figure 9-7: Connecting two heating loops*.

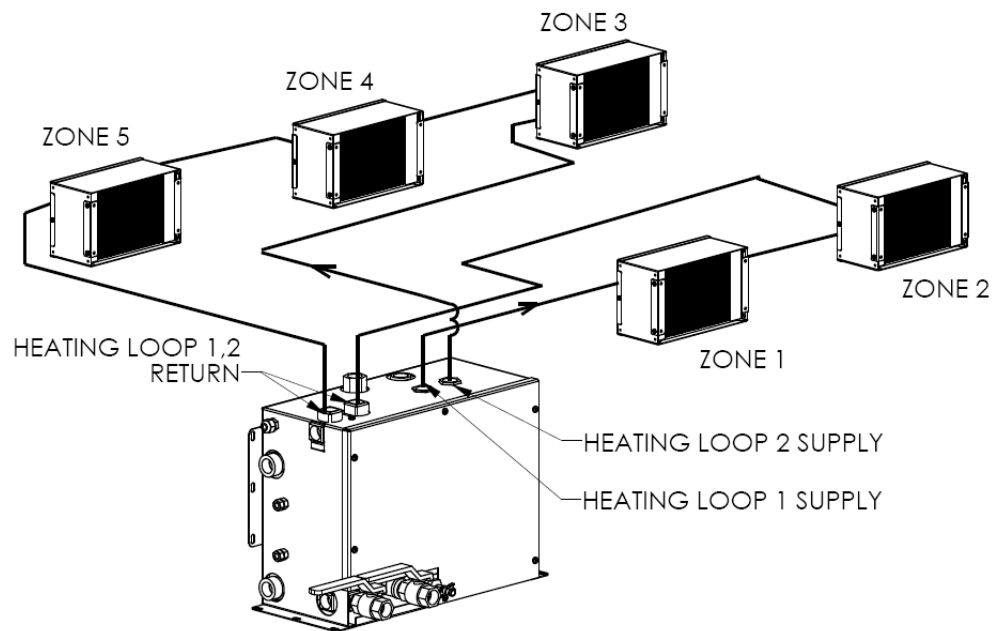

**Figure 9-7: Connecting two Heating loops.**

**! DANGER**

Use only a non-toxic propylene glycol based coolant with additives generally recognized as safe "GRAS" by the FDA in the coolant side of the Distribution Module. Refer to the anti-freeze manufacturer recommendations for instructions for your particular application.

**NOTICE**

Do not operate the Oasis™ Heating Module and Distribution Module, DM12 (Optional) until coolant is in the Oasis™ Heating Module and Distribution Module and all trapped air has been bled.

All plumbing lines must be run and secured so as to prevent damage, chafing and kinking.

## 9.5 Filling/Purging the heating system

The Distribution module contains two valves with ½"NPT connections to be used for filling the heating loop. To initially fill up and bleed the air out of the system, do the following:

1. Connect a hose to the outlet of a diaphragm pump and to the "fill inlet valve" on the distribution module. Attach a hose to the

inlet of a diaphragm pump and place the hose in a container filled with a 50/50 mixture of propylene glycol and water (see Figure 9-8).

2. Connect a hose to the "fill outlet valve" on the distribution module and place the other end of the hose in the same container.

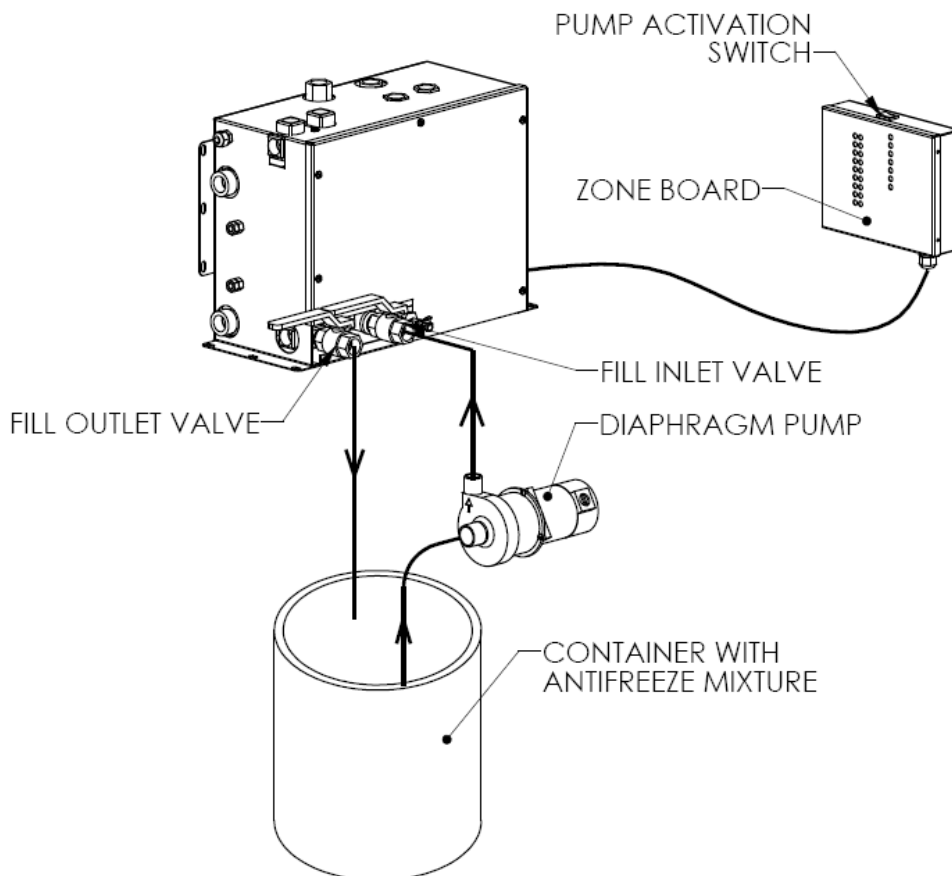

**Figure 9-8: Initial fill up Oasis system**

3. Open both valves on the Distribution module.

4. Turn ON the diaphragm pump. This will prime the pumps in the Oasis Distribution Module. It may be necessary to fill up the container with more coolant as the air is being bled from the system.

5. Turn on the pump activation switch, located on top of the zone box, this will activate the pumps inside the distribution module and fill up both heating loops.

6. Once the coolant in the container remains at the same level and there appears to be no air in the return stream from the fill outlet hose, close the valves on the distribution module and stop the diaphragm pump.
7. Turn off the pump activation switch.
8. The Oasis heating system is ready to be operated.

## 9.6 Electrical Connection

### WARNING

---

All electrical connections and wiring must comply with normally-accepted 12 VDC wiring practices, local regulations and ABYC/RVIA standards. Only a qualified electrical installer should complete the wiring. All field wiring is to be in accordance with CSA Standard C22.1, Canadian Electrical Code Part I or the National Electrical Code, ANSI/NFPA 70.

---

### 12 VDC

- Primary DC power to the module should originate after the master disconnect switch from a dedicated connection on the house battery bank.
- The power connection to the module from the power supply is through the Distribution Module Zone Control Board itself. A 25 amp fuse or breaker must be included inline from the power source to the positive connection on the zone board. The primary power wire gauge must be sized to permit no more than a 3% voltage drop from the power supply to the zone board. There are no direct 12 VDC power connections onto the Distribution Module itself. Refer to *Figure 9-9: Distribution Module Wiring*.

## 9.7 Distribution Module Zone Control Board

### Multi-Pin Connectors

The Zone Control Board has four multi-pin connectors, see *Figure 9-9: Distribution Module Wiring*, that are to be connected through connector cords (supplied) to the matching multi-pin connectors as follows:

- 10 pin connector to Heating Module Remote Operating Panel.
- 8 pin connector to Heating Module (connector cord transitions to a 9 pin connector for the Heating Module).
- 12 pin connector to Distribution Module (connector cord transitions to a 9 pin connector for the Distribution Module).
- 14 pin connector to thermostat and cabin fan connector plug.

### Cabin Fan leads

- The positive (red) lead from each cabin fan is to be attached to one of the trailing cabin fan leads, color coded for zones, from the thermostat and cabin fan connector plug.
- The negative lead from each cabin fan is to be attached to a ground terminal (not provided) that is connected to a battery ground.
- The cabin fan 1 leads (orange) can supply up to a maximum of 10 Amps. The other cabin fan leads 2-5 can supply up to a maximum of 5 Amps each. The total current draw is not to exceed 18 Amps for all cabin fan leads.
- If the system requires higher amperage draws, install a separate relay to power the fans. This relay will use the existing fan circuit as a signal and must be wired to a secondary power source (not the heater's control board). See Figure 5-3.



### Thermostat Leads

- The power lead to the thermostat is to be attached to a power terminal (not provided) that is connected to the battery.
- The return lead from each thermostat is to be attached to one of the trailing thermostat leads, color coded for zones, from the thermostat and cabin fan connector plug.

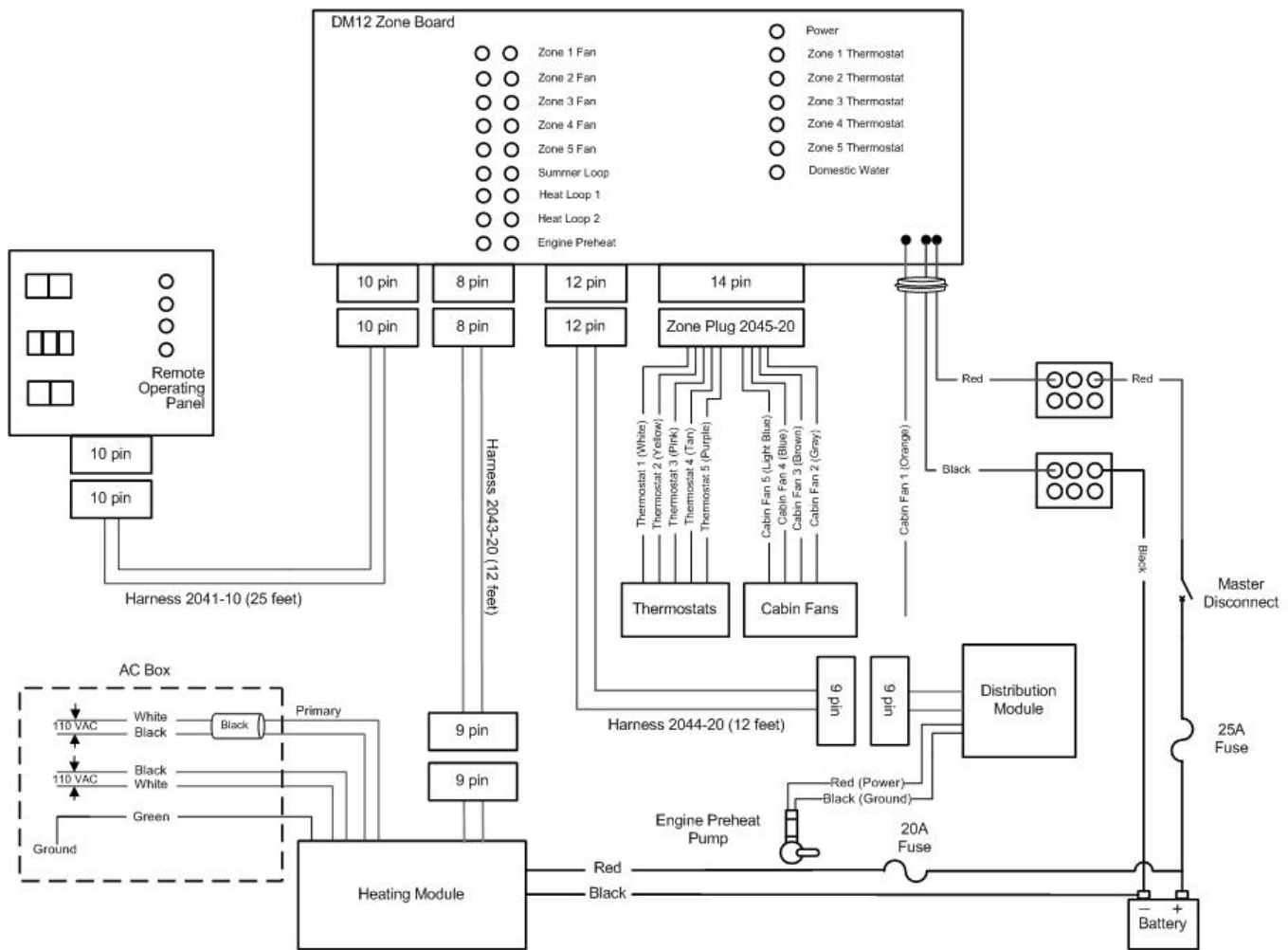

Figure 9-9: Distribution Module Wiring

## Section 9, Installing the Distribution Module

If the zone board is being used without the distribution module, use the following wiring diagram:

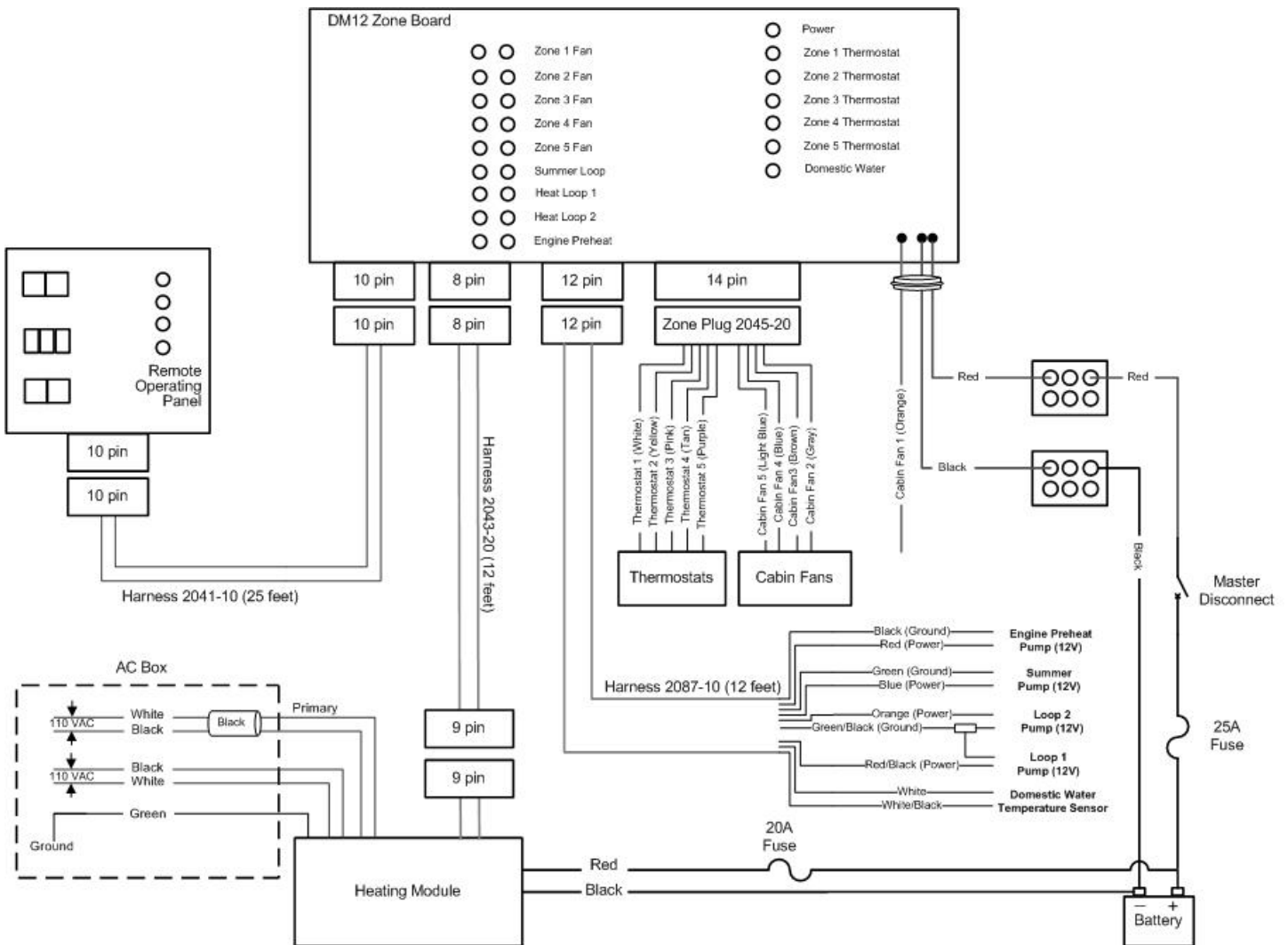

Figure 9-10: Zone Board Wiring (No DM12)

## 9.8 Inspection and Testing

After all components have been properly installed according to ABYC Industry Standards and Practices and the recommendations of this Manual, the Distribution Module and Oasis™ Heating Module should be inspected using the **Inspection Check Sheet** in this Manual. The **Inspection Check Sheet** is divided into relevant sections allowing each phase of the Inspection to be carried out systematically, and then signed off by authorized personnel.

## 9.9 Hot water temperature adjustment

The distribution module has the option to adjust the temperature of the domestic hot water outlet. Standard this temperature is set at 120F (49°C). In order to adjust the temperature, the front cover has to be removed. The front cover can be removed by removing the 6 Philips head screws. The mixing valve adjustment knob is shown in the figure below.

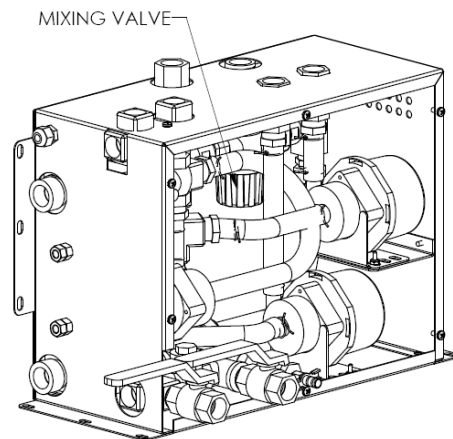

**Figure 9-11: Mixing valve location**

### WARNING

The parts inside the module are **HOT** when in operation. Use gloves when adjusting the mixing valve.

Turning the knob left (clockwise from top view) will increase the hot water outlet temperature up to a maximum of 145F (63°C). Turning the knob right (counter-clockwise) will decrease the hot water outlet temperature down to minimal 100F (38°C). Mount the cover back in place after the adjustment.

# Warranty And Service

## Warranty

**Warranty cards must be filled in completely, signed by the Owner and Dealer and returned to ITR within 30 days of the date of the original installation.**

ITR warrants the **OASIS® heating module, Distribution module and OASIS® COMBI, (referred to as "heater(s)")** and all accessories or other supplied components with the original purchase to be free of defects in materials and workmanship under design usage and service conditions for one (1) year from the heater serial number label manufacturing date or from acceptable proof of the date of purchase of the unit in which the heating system is installed. Warranty replacement parts are covered for the remainder of the heater's warranty.

**This warranty does not apply to damage or failure of the heater, or the vessel or vehicle into which it was installed, due to improper installation, assembly, maintenance, or abuse, accident, or the use of parts not supplied by ITR.**

## Installations

The purchaser and installer are advised that specific rules and regulations may be in effect with respect to the installation of the "heater". It is the installer's responsibility to review and comply with all such rules and regulations.

Non-standard installations, that is, those requiring a departure from published installation instructions, should not be undertaken without first having consulted and obtained the written approval of ITR. Coverage for warrantable parts will, at the discretion of ITR, be made to the claimant in the form of repair, replacement, or credit.

**"Heaters" installed using non standard, industry accepted procedures and without ITR's or an authorized Dealer's approval will be limited to a 90 day warranty measured from the heater serial number label manufacturing date.**



## Limited Warranty

**The following warranties are in lieu of all other warranties and conditions. ITR makes no other warranties, representations, or conditions, express or implied, and there are expressly excluded all implied or statutory warranties or conditions of merchantability of fitness for a particular purpose and those arising by statute or otherwise in law of from a course of dealing or usage of trade.**

**The stated express warranties are in lieu of all liabilities or obligations for damages arising out of or in connection with the delivery, use, performance, or licensing of the product or in connection with any services performed. In no event whatsoever, shall ITR be liable for indirect, consequential, exemplary, incidental, special or similar damages including but not limited to lost profits, lost business revenue, failure to realize expected savings, other commercial or economic loss of any kind or any claim against ITR by any other party arising out of or in connection with the sale, delivery, use, performance, or repair or in connection with any services performed, even if ITR has been advised of the possibility of such damages, whether based upon warranty, contract, or negligence. ITR's maximum liability shall not in any case exceed the contract price for the products claimed to be defective. ITR warrants its products; ITR authorized dealers/service centers and installers provide warranty for installation. Any warrantable service and or labour is the responsibility of ITR and should be performed by an authorized dealer unless other arrangements are authorized.**

**No one is authorized to increase, alter, or enlarge ITR's responsibilities or obligations under these warranties. Warranties are void if the original serial number has been removed or altered, or cannot be readily determined.**

## Owner's Responsibilities

**Before the expiration of the warranty, the Owner must give notice to a registered ITR Dealer of failures, if any, considered to be warrantable and deliver the defective "heater" to such dealer.** The Owner is responsible for all repairs made to the engine, equipment, vessel, or vehicle in which the "heater" is installed, other than the "heater". The Owner is responsible for lodging, meals, and other incidental costs incurred by the Owner as a result of a warrantable failure. The Owner is responsible for "down time" expenses, and all business costs and losses resulting from a warrantable failure.

**ITR IS NOT RESPONSIBLE FOR INCIDENTAL OR CONSEQUENTIAL DAMAGES.**

## Not Covered Under Warranty

This warranty will not apply to:

- Normal usage, wear, and tear on parts, including but not limited to, fuel filter, air filter, nozzle, fuses, igniter, and carbon brushes.
- Parts or products which malfunction due to improper installation, including but not limited to malfunctions causing inadequacies in; air, fuel or coolant flow, voltage due to wiring, shock or vibration.
- Any progressive damage to the engine, vessel, or vehicle arising out of failure of the "heater".
- "Heaters" which have been modified or use of non-standard parts not approved by ITR.
- "Heaters" that have been abused, damaged, vandalized, or received improper maintenance.
- **Removal and re-installation expenses of the "heater" unless specific written permission has been obtained from ITR.**
- Travel time and expenses incurred by an ITR dealer or other personnel to perform warranty related work on the "heater"

- Diagnosis or repairs when caused by problems not directly related to the “heater” or due to empty fuel tanks or poor fuel quality, fuel additives, acidic water, electrolysis, incorrect vessel bonding leading to abnormal corrosion.
- Running the system dry or without appropriate preservatives (antifreeze), causing damage to the heat exchanger, pump seals, etc.
- Exposing the heater to an environment detrimental to its effective operation (such as excessively wet, dirty, or hot areas).
- Other products which ITR does not manufacture.
- Any products or parts which have been used in a manner contrary to ITR’s printed instructions.

**PLEASE FOLLOW THE RECOMMENDATIONS INCLUDED IN THIS MANUAL.**

## Customer Service Calls

Normal service calls are at the owner’s expense.

**CHECK THE TROUBLESHOOTING CHAPTER OF THIS MANUAL TO SEE IF YOUR PROBLEM IS ADDRESSED.**

When calling with a service problem, please have the following information at hand:

- The model number and serial number of your heater and main electronic control board.
- If your heater is already installed, ensure you are familiar with the design and installation setup.
- Have ready a detailed description of the problem and keep the manual handy to refer to.

## Returns

**To obtain warranty service, the owner must:**

- Provide a full description of the problem to your dealer and ITR. ITR will determine if the problem is covered under the ITR warranty.

- If ITR determines that the problem is covered under warranty, they will provide you with a Repair or Return Goods Authorization (RGA) number for any warranty return, repair or service.. ITR will refuse any return package without a proper RGA number.
- If ITR determines that “heater” repairs will be covered under warranty under in-field conditions, ITR will authorize the in-field warranty service personnel as to specific conditions and limits for parts and labor used in the repair. Any other incurred costs will not be covered under the warranty.
- When shipping your product, pack securely to prevent damage, indicate the RGA and serial number of the heater on the outside of the shipping container, and ship prepaid and insured to ITR.
- In the shipping container, provide written details of the problems, RGA number, manufacturing date as indicated by the serial number label, serial number, proof of purchase, and a return address.

**After repair or replacement** of products under warranty, ITR will return the product to the customer via standard (non expedited) delivery. Factory repairs or replacement will be done as quickly as possible, with an estimated five working day turn around.

## Telephone Service



There is no charge for help or service information given over the telephone or by fax. Any recommendation or advice from ITR or any of its employees, or Dealers, is given only in good faith as an accommodation to the customer. Such information should not be relied upon by the customer without an independent verification of its applicability to the customer’s particular situation. For customer service or other information:

### **Call the Dealer from whom you bought the heater, or call ITR**

#### **IN CANADA:**

2431 Simpson Road,  
Richmond, BC Canada V6X 2R2  
Tel: 1-800-755-1272 or 604-278-1272  
Fax: 604-278-1274  
Email: [info@itrheat.com](mailto:info@itrheat.com)

#### **IN THE UNITED STATES:**

11915 NE 56<sup>th</sup> Circle Suite B  
Vancouver, WA USA 98682  
Tel: 1-800-993-4402 or 360-993-4877  
Fax: 360-993-1105  
Website: <http://www.itrheat.com>



PLEASE FILL OUT FOR YOUR OWN REFERENCE

## INTERNATIONAL THERMAL RESEARCH

CANADA 2431 Simpson Road,  
Richmond, B.C. Canada V6X 2R2  
Ph 604-278-1272 Fax 604-278-1274  
[www.itrheat.com](http://www.itrheat.com)

### WARRANTY REGISTRATION CARD

Limited Warranty see manual  
(Please print or type)

#### HEATER

Serial No. \_\_\_\_\_

→ SERIAL NUMBER **MUST** BE RECORDED FOR WARRANTY TO APPLY

Installed by:      Owner     Dealer

Date Installed: \_\_\_\_\_

Date Purchased. \_\_\_\_\_

#### TYPE OF INSTALLATION

Marine     RV     Truck     Other

#### OWNER

\_\_\_\_\_  
Name

\_\_\_\_\_  
Address

\_\_\_\_\_  
City

\_\_\_\_\_  
State / Province

\_\_\_\_\_  
Country

\_\_\_\_\_  
Zip / Postal code

\_\_\_\_\_  
Telephone

\_\_\_\_\_  
Signature

\_\_\_\_\_  
Date

#### AUTHORIZED DEALER NAME

**NOTE:** THIS WARRANTY CARD MUST BE FILLED IN COMPLETELY, SIGNED BY THE ORIGINAL OWNER AND THE DEALER AND RETURNED TO ITR WITHIN 30 DAYS OF THE DATE OF INSTALLATION.