

REVISIONS			DATE	REV	ZONE	DESCRIPTION	DWN	CHK	APP
REVISED PER ECO# 2505				D				MAR	

PULSE GENERATOR

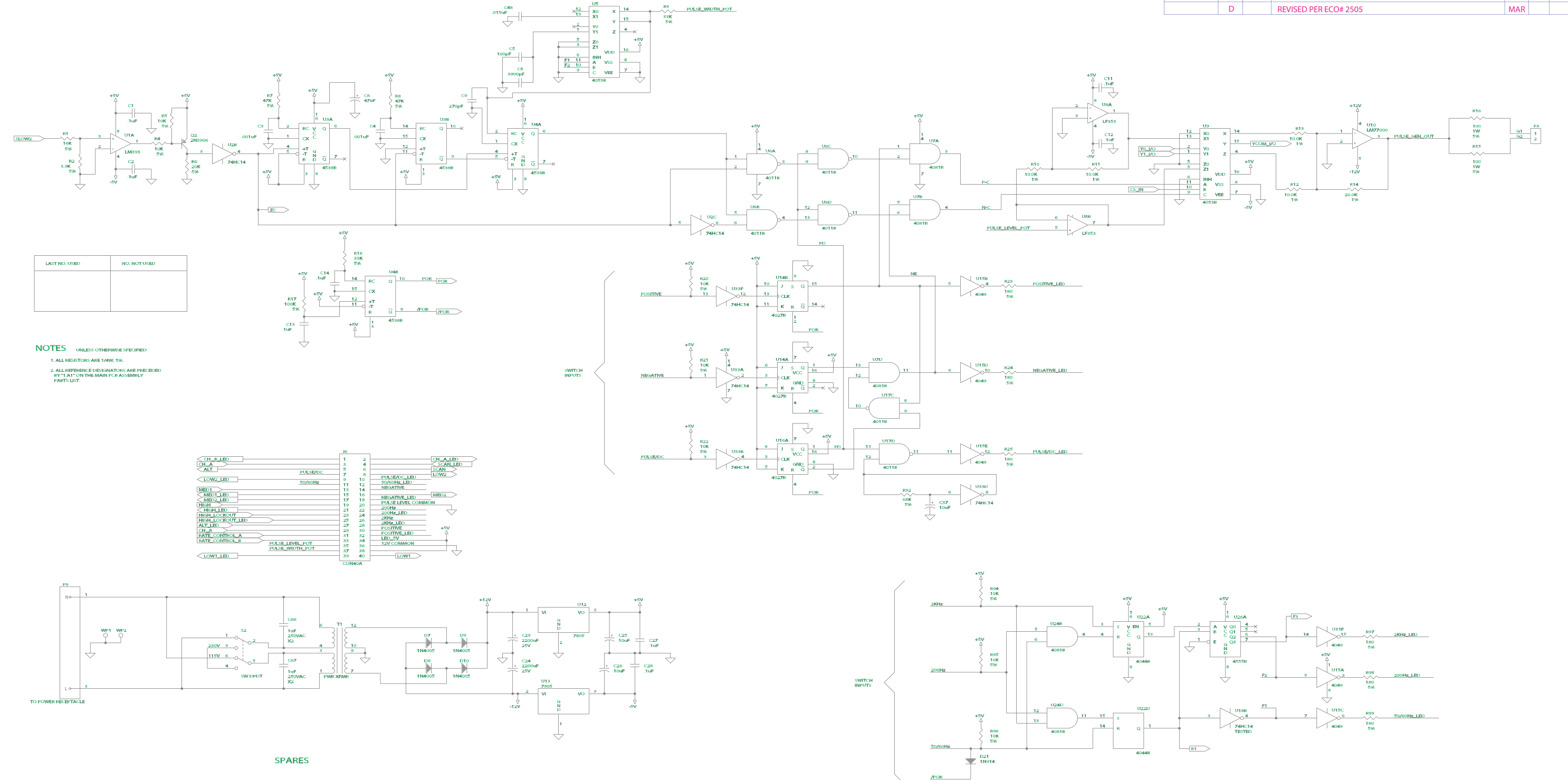

LAST NO. USED	NO. NOT USED

NOTES UNLESS OTHERWISE SPECIFIED:
 1. ALL RESISTORS ARE 1/4W, 5%
 2. ALL REFERENCE DESIGNATORS ARE PRECEDED BY "1A1" ON THE MAIN PCB ASSEMBLY PARTS LIST.

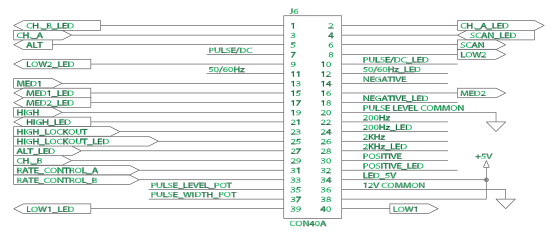

SPARES

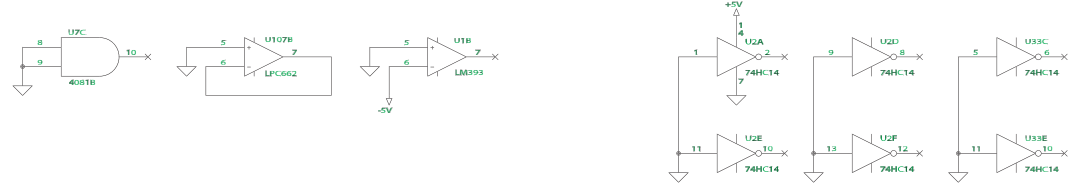

06-3106-08

FILENAME: 063106D1	TOLERANCES UNLESS OTHERWISE SPECIFIED: ANGULAR = 1° 0' LINEAR: X = ± .020 XX = ± .010 XXX = ± .005 FRACTIONAL = 1/64	HUNTRON INSTRUMENTS, INC.
PROPRIETARY NOTICE This document and the technical data herein disclosed, are proprietary to Huntron Instruments, Inc. and shall not, without express written permission of Huntron Instruments, Inc. be used, released or disclosed in whole or in part, or used to solicit quotations from a competitive source or used for manufacture by anyone other than Huntron Instruments, Inc. The information herein has been developed by Huntron Instruments, Inc. and is only for their use. This information is confidential material.	DESCRIPTION SCHEMATIC, TR210 MAIN PCA	DRAWING NUMBER 06-3106-08
DRAWN: J. WHEELLOCK CHECK: APPR:	NAME: J. WHEELLOCK DATE: 11/6/97	SIZE: CAGE D 57705 PART NUMBER 06-3106 REV D
SCALE: N.T.S.	SHEET 1 OF 3	

REVISIONS			DATE	REV	ZONE	DWN	CHK	APP
DESCRIPTION								
SEE SHEET 1								

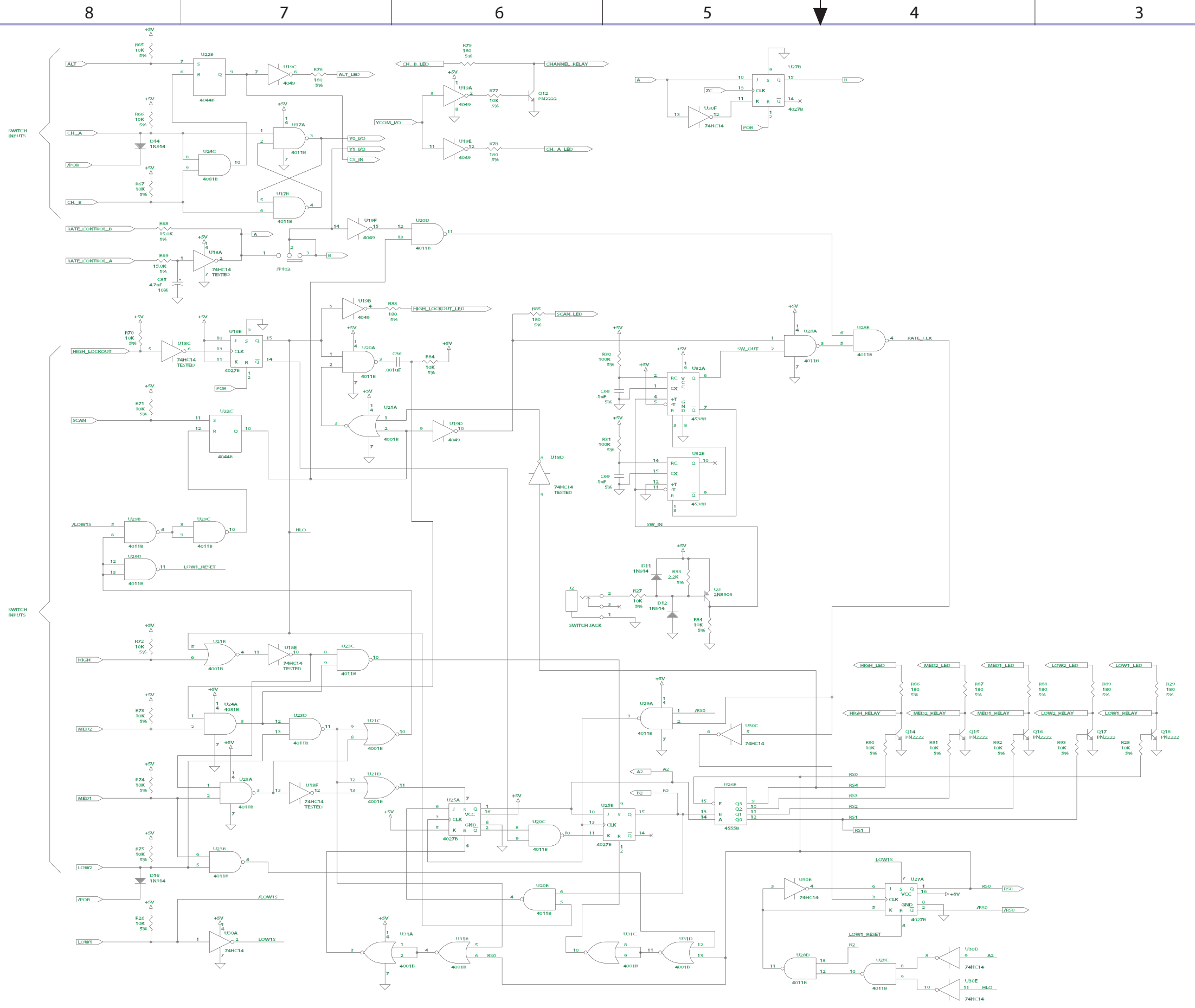

06-3106-08

HUNTRON INSTRUMENTS, INC.

SEE SHEET 1 FOR TOLERANCE

FILENAME: 063106D2.DWG

SIZE	CAGE	DRAWING NUMBER	REV
D	57705	06-3106-08	D
SCALE	N.T.S.	SHEET 2 OF 3	

8

7

6

5

4

3

2

1

DATE	REV	ZONE	REVISIONS			
			DESCRIPTION	DWN	CHK	APP
			SEE SHEET 1			

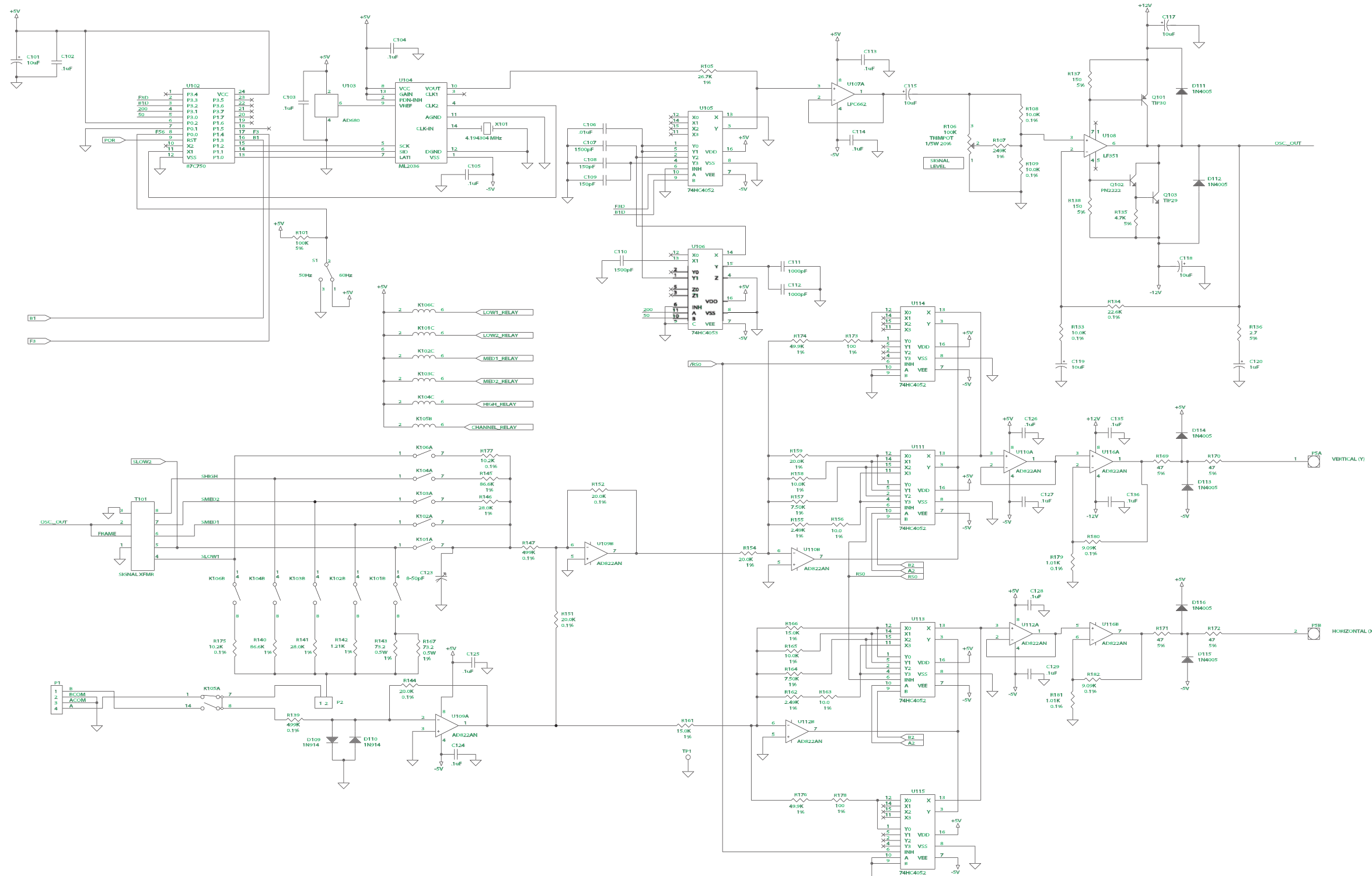

8

7

6

5

4

3

2

1

06-3106-08

HUNTRON INSTRUMENTS, INC.

SEE SHEET 1 FOR TOLERANCE

FILENAME: 063106D3.DWG

SIZE	CAGE	DRAWING NUMBER	REV
D	57705	06-3106-08	D
SCALE	N.T.S.	SHEET 3 OF 3	