



HEIDENHAIN



Linear Encoders

For Numerically Controlled
Machine Tools

July 2014



Further information is available on the Internet at www.heidenhain.de as well as upon request.

Product brochures:

- Exposed Linear Encoders
- Angle Encoders With Integral Bearing
- Angle Encoders Without Integral Bearing
- Rotary Encoders
- HEIDENHAIN Subsequent Electronics
- HEIDENHAIN Controls
- Measuring Systems For Machine Tool Inspection and Acceptance Testing

Technical information brochures:



- Interfaces for HEIDENHAIN Encoders
- Accuracy of Feed Axes
- Safety-Related Position Measuring Systems
- EnDat 2.2—Bidirectional Interface for Position Encoders
- Encoders for Direct Drives

This catalog supersedes all previous editions, which thereby become invalid. The basis for ordering from HEIDENHAIN is always the catalog edition valid when the contract is made.

Standards (ISO, EN, etc.) apply only where explicitly stated in the catalog.

Comprehensive descriptions of all available interfaces as well as general electrical information are included in the *Interfaces for HEIDENHAIN Encoders* catalog.

Contents

Overview		
	Linear encoders	4
	Selection guide	6
Technical features and mounting information		
	Measuring principles	8
	Measuring standard	8
	Absolute measuring method	8
	Incremental measuring method	9
	Photoelectric scanning	10
	Measuring accuracy	12
	Mechanical design types and mounting guidelines	14
	General mechanical information	18
Specifications		
<i>Linear encoders</i>	<i>Series or model</i>	
For absolute position measurement	LC 400 series	20
	LC 100 series	24
For absolute position measurement over large measuring lengths	LC 200 series	28
For incremental linear measurement with very high repeatability	LF 485	30
	LF 185	32
For incremental linear measurement	LS 400 series	34
	LS 100 series	36
For incremental linear measurement over large measuring lengths	LB 382—single-section	38
	LB 382—multi-section	40
Electrical connection		
	Incremental signals	42
	 1 V _{PP}	
	 TTL	43
	Position values	44
	EnDat	
	Siemens, Fanuc, Mitsubishi	45
	Cables and connecting elements	47
	Diagnostic and testing equipment	52
	Interface electronics	54

Linear encoders for numerically controlled machine tools

Linear encoders from HEIDENHAIN for numerically controlled machine tools can be used nearly everywhere. They are ideal for machines and other equipment whose feed axes are in a servo loop, such as milling machines, machining centers, boring machines, lathes and grinding machines. The beneficial dynamic behavior of the linear encoders, their high permissible traversing speed, and their acceleration in the direction of measurement predestine them for use on highly-dynamic conventional axes as well as on direct drives.

HEIDENHAIN also supplies linear encoders for other applications, such as

- Manual machine tools
- Presses and bending machines
- Automation and production equipment

Please request further documentation, or inform yourself on the Internet at www.heidenhain.de.

Advantages of linear encoders

Linear encoders measure the position of linear axes without additional mechanical transfer elements. The control loop for position control with a linear encoder also includes the entire feed mechanics. Transfer errors from the mechanics can be detected by the linear encoder on the slide, and corrected by the control electronics. This makes it possible to eliminate a number of potential error sources:

- Positioning error due to thermal behavior of the recirculating ball screw
- Reversal error
- Kinematics error through ball-screw pitch error

Therefore, linear encoders are indispensable for machine tools on which high **positioning accuracy** and a high **machining rate** are essential.

Mechanical design

The linear encoders for numerically controlled machine tools are sealed encoders: An aluminum housing protects the scale, scanning carriage and its guideway from chips, dust, and fluids. Downward-oriented elastic lips seal the housing.

The scanning carriage travels along the scale on a low-friction guide. A coupling connects the scanning carriage with the mounting block and compensates the misalignment between the scale and the machine guideways.

Depending on the encoder model, lateral and axial offsets of ± 0.2 mm to ± 0.3 mm between the scale and mounting block are permissible.



Thermal characteristics

The combination of increasingly rapid machining processes with completely enclosed machines leads to ever-increasing temperatures within the machine's work envelope. Therefore, the thermal behavior of the linear encoders used becomes increasingly important, since it is an essential criterion for the working accuracy of the machine.

As a general rule, the thermal behavior of the linear encoder should match that of the workpiece or measured object. If the temperature changes, the linear encoder must expand or contract in a defined, reproducible manner. Linear encoders from HEIDENHAIN are designed for this.

The graduation carriers of HEIDENHAIN linear encoders have defined coefficients of thermal expansion (see *Specifications*). This makes it possible to select the linear encoder whose thermal behavior is best suited to the application.

Dynamic behavior

The constant increases in efficiency and performance of machine tools necessitate ever-higher feed rates and accelerations, while at the same time the high level of machining accuracy must be maintained. In order to transfer rapid and yet exact feed motions, very high demands are placed on rigid machine design as well as on the linear encoders used.

Linear encoders from HEIDENHAIN are characterized by their high rigidity in the measuring direction. This is a very important prerequisite for high-quality path accuracies on a machine tool. In addition, the low mass of moving components contributes to their excellent dynamic behavior.

Availability

The feed axes of machine tools travel quite large distances—a typical value is 10000 km in three years. Therefore, robust encoders with good long-term stability are especially important: They ensure the constant availability of the machine.

Due to the details of their design, linear encoders from HEIDENHAIN function properly even after years of operation. The contact-free principle of photoelectrically scanning the measuring standard, as well as the ball-bearing guidance of the scanning carriage in the scale housing ensure a long lifetime. This encapsulation, the special scanning principles and, if needed, the introduction of compressed air, make the linear encoders very resistant to contamination. The complete shielding concept ensures a high degree of electrical noise immunity.

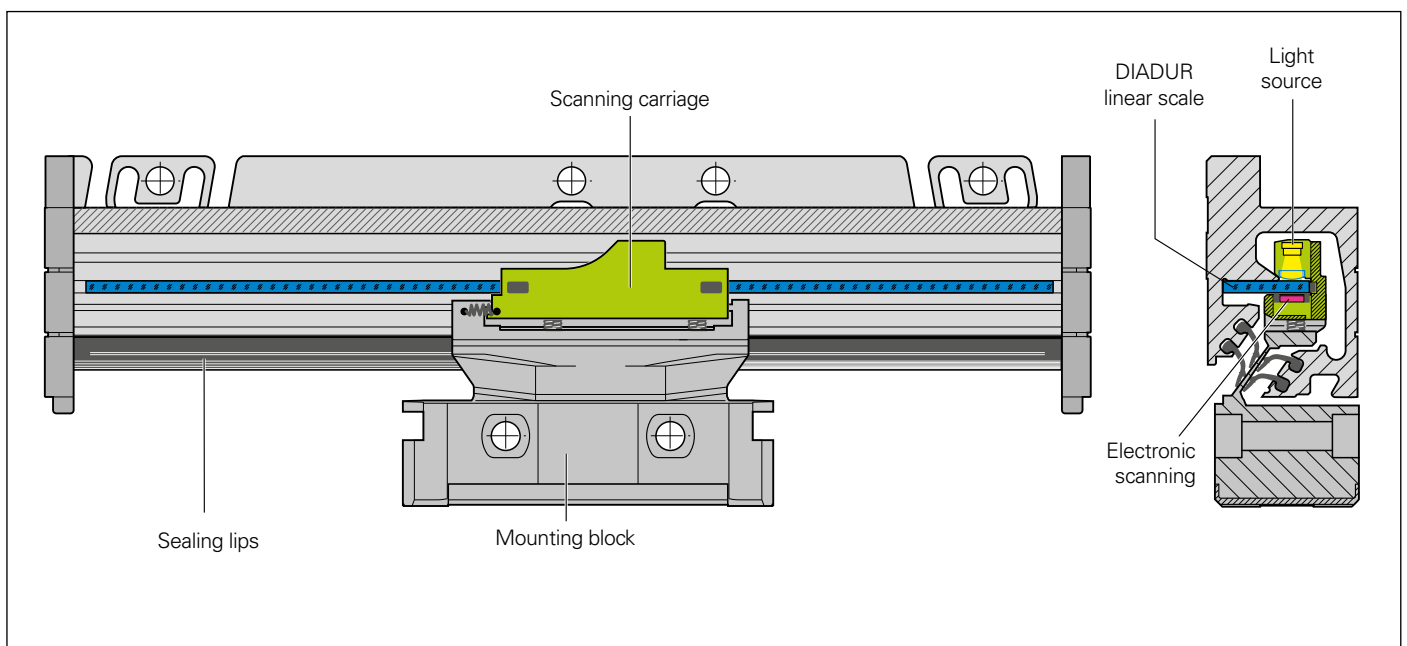

Schematic design of the **LC 115** sealed linear encoder

Selection guide

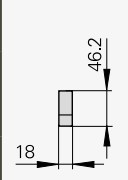
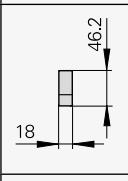
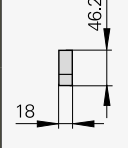

Linear encoders with slimline scale housing

The linear encoders with **slimline scale housing** are designed for **limited installation space**. Larger measuring lengths and higher acceleration loads are made possible by using mounting spars or clamping elements.

	Cross section	Accuracy grade	Measuring length ML	Scanning principle
Absolute position measurement <ul style="list-style-type: none"> Glass scale 		± 5 µm ± 3 µm	70 mm to 1240 mm <i>With mounting spar or clamping elements:</i> 70 mm to 2040 mm	Single-field scanning
Incremental linear measurement with very high repeatability <ul style="list-style-type: none"> Steel scale Small signal period 		± 5 µm ± 3 µm	50 mm to 1220 mm	Single-field scanning
Incremental linear measurement <ul style="list-style-type: none"> Glass scale 		± 5 µm ± 3 µm	70 mm to 1240 mm <i>with mounting spar:</i> 70 mm to 2040 mm	Single-field scanning

Linear encoders with full-size scale housing

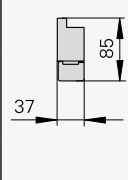
The linear encoders with **full-size scale housing** are characterized by their **sturdy construction, high resistance to vibration** and **large measuring lengths**. The scanning carriage is connected with the mounting block over an oblique blade that permits mounting both in **upright and reclining positions** with the same protection rating.

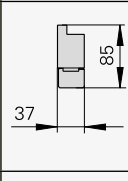
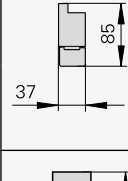
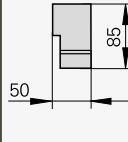
Absolute position measurement <ul style="list-style-type: none"> Glass scale 		± 5 µm ± 3 µm	140 mm to 4240 mm	Single-field scanning
Absolute position measurement for large measuring lengths <ul style="list-style-type: none"> Steel scale tape 		± 5 µm	3240 mm to 28040 mm	Single-field scanning
Incremental linear measurement with very high repeatability <ul style="list-style-type: none"> Steel scale Small signal period 		± 3 µm ± 2 µm	140 mm to 3040 mm	Single-field scanning
Incremental linear measurement <ul style="list-style-type: none"> Glass scale 		± 5 µm ± 3 µm	140 mm to 3040 mm	Single-field scanning
Incremental linear measurement for large measuring lengths <ul style="list-style-type: none"> Steel scale tape 		± 5 µm	440 mm to 30040 mm Up to 72040 mm measuring length upon request	Single-field scanning

	Interface	Signal period	Model	Page
	EnDat 2.2	–	LC 415	20
	EnDat 2.2 with $\sim 1 V_{PP}$	20 μm	LC 485	
	DRIVE-CLiQ	–	LC 495S	22
	Fanuc αi		LC 495F	
	Mitsubishi		LC 495M	
	$\sim 1 V_{PP}$	4 μm	LF 485	30
			LS 487	
	$\sim 1 V_{PP}$	20 μm	LS 487	34
	\square TTL	To 1 μm	LS 477	
	EnDat 2.2	–	LC 115	24
	EnDat 2.2 with $\sim 1 V_{PP}$	20 μm	LC 185	
	DRIVE-CLiQ	–	LC 195S	26
	Fanuc αi		LC 195F	
	Mitsubishi		LC 195M	
	EnDat 2.2	–	LC 211	28
	EnDat 2.2 with $\sim 1 V_{PP}$	40 μm	LC 281	
	Fanuc αi	–	LC 291F	
	Mitsubishi		LC 291M	
	$\sim 1 V_{PP}$	4 μm	LF 185	32
	$\sim 1 V_{PP}$	20 μm	LS 187	36
	\square TTL	To 1 μm	LS 177	
	$\sim 1 V_{PP}$	40 μm	LB 382	38



LC 415



**LF 485
LS 487**



LC 115



LF 185



LC 211

Measuring principles

Measuring standard

HEIDENHAIN encoders with optical scanning incorporate measuring standards of periodic structures known as graduations.

These graduations are applied to a carrier substrate of glass or steel. The scale substrate for large measuring lengths is a steel tape.

HEIDENHAIN manufactures the precision graduations in specially developed, photolithographic processes.

- AURODUR: matte-etched lines on gold-plated steel tape with typical graduation period of 40 μm
- METALLUR: contamination-tolerant graduation of metal lines on gold, with typical graduation period of 20 μm
- DIADUR: extremely robust chromium lines on glass (typical graduation period of 20 μm) or three-dimensional chromium structures (typical graduation period of 8 μm) on glass
- SUPRADUR phase grating: optically three dimensional, planar structure; particularly tolerant to contamination; typical graduation period of 8 μm and finer
- OPTODUR phase grating: optically three dimensional, planar structure with particularly high reflectance, typical graduation period of 2 μm and finer

Along with these very fine grating periods, these processes permit a high definition and homogeneity of the line edges. Together with the photoelectric scanning method, this high edge definition is a precondition for the high quality of the output signals.

The master graduations are manufactured by HEIDENHAIN on custom-built high-precision dividing engines.

Absolute measuring method

With the **absolute measuring method**, the position value is available from the encoder immediately upon switch-on and can be called at any time by the subsequent electronics. There is no need to move the axes to find the reference position. The absolute position information is read **from the scale graduation**, which is formed from a serial absolute code structure. A separate incremental track is interpolated for the position value and at the same time is used to generate an optional incremental signal.

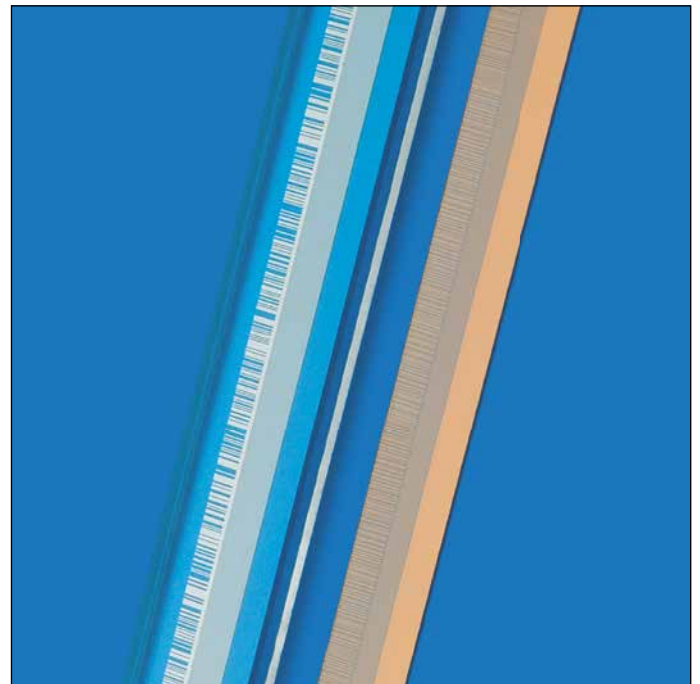

Graduations of absolute linear encoders

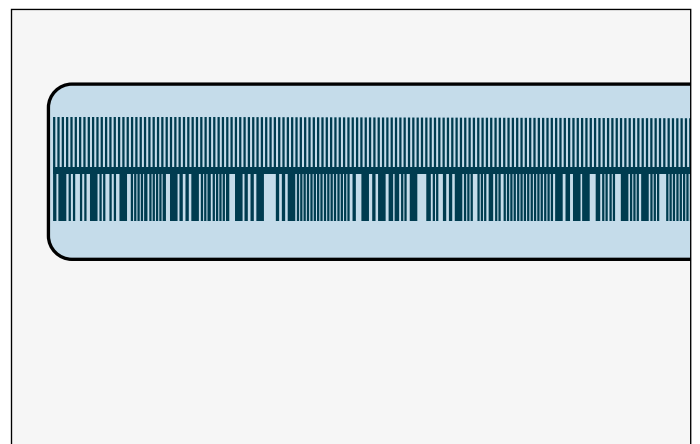

Schematic representation of an absolute code structure with an additional incremental track (LC 485 as example)

Incremental measuring method

With the **incremental measuring method**, the graduation consists of a periodic grating structure. The position information is obtained **by counting** the individual increments (measuring steps) from some point of origin. Since an absolute reference is required to ascertain positions, the scales or scale tapes are provided with an additional track that bears a **reference mark**. The absolute position on the scale, established by the reference mark, is gated with exactly one signal period.

The reference mark must therefore be scanned to establish an absolute reference or to find the last selected datum.

In the most unfavorable case this may necessitate machine movements over large lengths of the measuring range. To speed and simplify such "reference runs," many HEIDENHAIN encoders feature **distance-coded reference marks**—multiple reference marks that are individually spaced according to a mathematical algorithm. The subsequent electronics find the absolute reference after traversing two successive reference marks—only a few millimeters traverse (see table).

Encoders with distance-coded reference marks are identified with a "C" behind the model designation (e.g. LS 487C).

With distance-coded reference marks, the **absolute reference** is calculated by counting the signal periods between two reference marks and using the following formula:

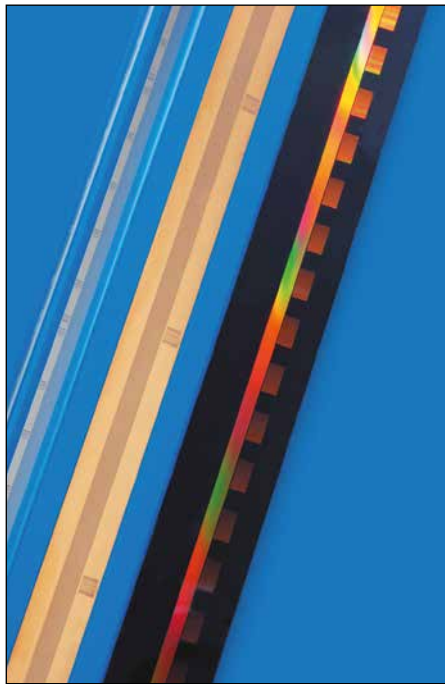

Graduations of incremental linear encoders

$$P_1 = (\text{abs } B - \text{sgn } B - 1) \times \frac{N}{2} + (\text{sgn } B - \text{sgn } D) \times \frac{\text{abs } M_{RR}}{2}$$

where:

$$B = 2 \times M_{RR} - N$$

Where:

P_1 = Position of the first traversed reference mark in signal periods

abs = Absolute value

sgn = Algebraic sign function ("+1" or "-1")

M_{RR} = Number of signal periods between the traversed reference marks

N = Nominal increment between two fixed reference marks in signal periods (see table below)

D = Direction of traverse (+1 or -1). Traverse of scanning unit to the right (when properly installed) equals +1.

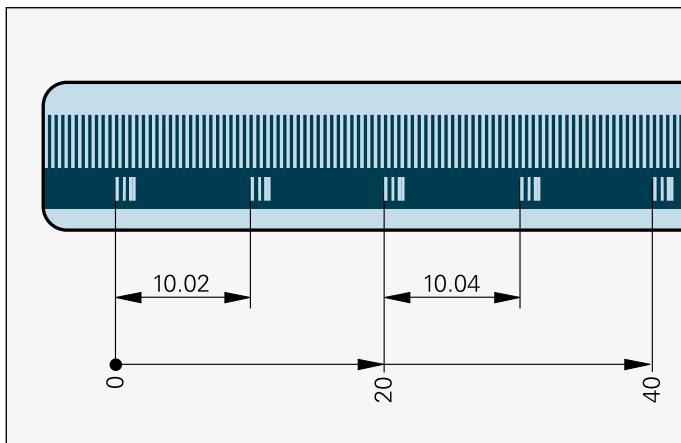

Schematic representation of an incremental graduation with distance-coded reference marks (LS as example)

	Signal period	Nominal increment N in signal periods	Maximum traverse
LF	4 μm	5 000	20 mm
LS	20 μm	1 000	20 mm
LB	40 μm	2 000	80 mm

Photoelectric scanning

Most HEIDENHAIN encoders operate using the principle of photoelectric scanning. Photoelectric scanning of a measuring standard is contact-free, and as such, free of wear. This method detects even very fine lines, no more than a few microns wide, and generates output signals with very small signal periods.

The finer the grating period of a measuring standard is, the greater the effect of diffraction on photoelectric scanning. HEIDENHAIN uses two scanning principles with linear encoders:

- The **imaging scanning principle** for grating periods of 20 μm and 40 μm .
- The **interferential scanning principle** for very fine graduations with grating periods of, for example, 8 μm .

Imaging principle

To put it simply, the imaging scanning principle functions by means of projected-light signal generation: Two scale gratings with equal or similar grating periods are moved relative to each other—the scale and the scanning reticle. The carrier material of the scanning reticle is transparent, whereas the graduation on the measuring standard may be applied to a transparent or reflective surface.

When parallel light passes through a grating, light and dark surfaces are projected at a certain distance, where there is an index grating. When the two gratings move relative to each other, the incident light is modulated. If the gaps in the gratings are aligned, light passes through. If the lines of one grating coincide with the gaps of the other, no light passes through. An array of photovoltaic cells converts these variations in light intensity into electrical signals. The specially structured grating of the scanning reticle filters the light to generate nearly sinusoidal output signals.

The smaller the period of the grating structure is, the closer and more tightly tolerated the gap must be between the scanning reticle and scale.

The LC, LS and LB linear encoders operate according to the imaging scanning principle.

Imaging principle

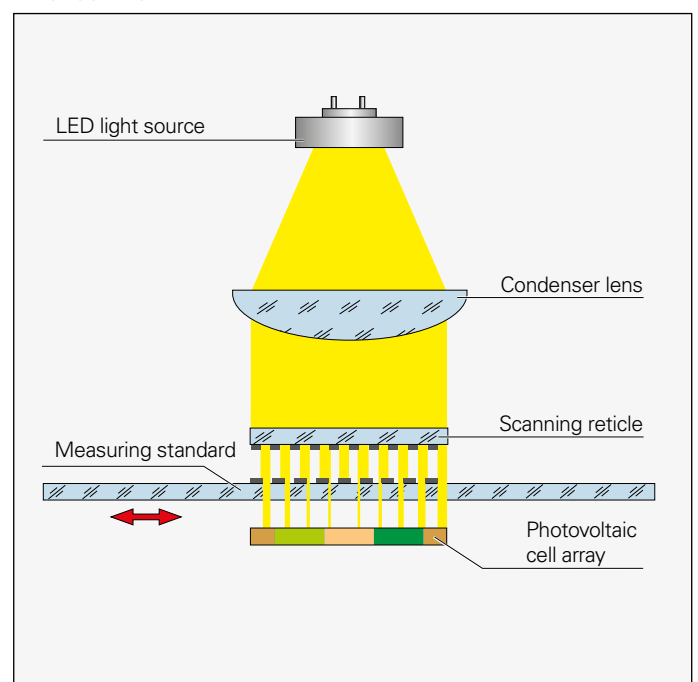

Interferential scanning principle

The interferential scanning principle exploits the diffraction and interference of light on a fine graduation to produce signals used to measure displacement.

A step grating is used as the measuring standard: Reflective lines 0.2 μm high are applied to a flat, reflective surface. In front of that is the scanning reticle—a transparent phase grating with the same grating period as the scale.

When a light wave passes through the scanning reticle, it is diffracted into three partial waves of the orders -1, 0, and +1, with approximately equal luminous intensity. The waves are diffracted by the scale such that most of the luminous intensity is found in the reflected diffraction orders +1 and -1. These partial waves meet again at the phase grating of the scanning reticle where they are diffracted again and interfere. This produces essentially three waves that leave the scanning reticle at different angles. Photovoltaic cells convert this alternating light intensity into electrical signals.

A relative motion of the scanning reticle to the scale causes the diffracted wave fronts to undergo a phase shift: When the grating moves by one period, the wave front of the first order is displaced by one wavelength in the positive direction, and the wavelength of diffraction order -1 is displaced by one wavelength in the negative direction. Since the two waves interfere with each other when exiting the grating, the waves are shifted relative to each other by two wavelengths. This results in two signal periods from the relative motion of just one grating period.

Interferential encoders function with grating periods of, for example, 8 μm, 4 μm and finer. Their scanning signals are largely free of harmonics and can be highly interpolated. These encoders are therefore especially suited for high resolution and high accuracy.

Sealed linear encoders that operate according to the interferential scanning principle are given the designation LF.

Interferential scanning principle (optics schematics)

- C Grating period
- ψ Phase shift of the light wave when passing through the scanning reticle
- Ω Phase shift of the light wave due to motion X of the scale

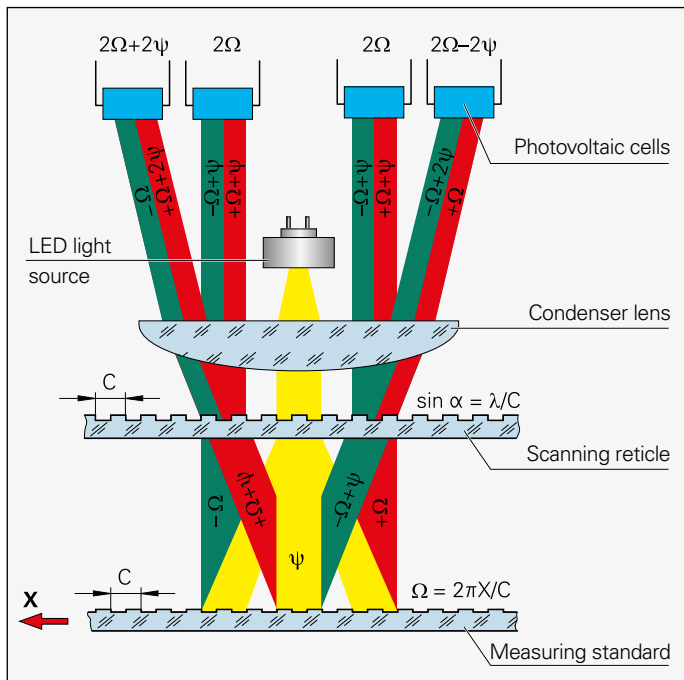

Measuring accuracy

The accuracy of linear measurement is mainly determined by:

- The quality of the graduation
- The quality of the scanning process
- The quality of the signal processing electronics
- The error from the scanning unit guideway to the scale

A distinction is made between position errors over relatively large paths of traverse—for example the entire measuring length—and those within one signal period.

Position error over the measuring range

The accuracy of sealed linear encoders is specified in grades, which are defined as follows:

The extreme values $\pm F$ of the measuring curves over any max. one-meter section of the measuring length lie within the accuracy grade $\pm a$. They are measured during the final inspection and documented in the calibration chart.

With sealed linear encoders, these values apply to the complete encoder system including the scanning unit. It is then referred to as the system accuracy.

Position error within one signal period

The position error within one signal period is determined by the signal period of the encoder, as well as the quality of the graduation and the scanning thereof. At any measuring position, it typically lies at $\pm 2\%$ to $\pm 0.5\%$ of the signal period (see table). The smaller the signal period, the smaller the position error within one signal period. It is of critical importance both for accuracy of a positioning movement as well as for velocity control during the slow, even traverse of an axis, and therefore for surface quality and the quality of the machined part.

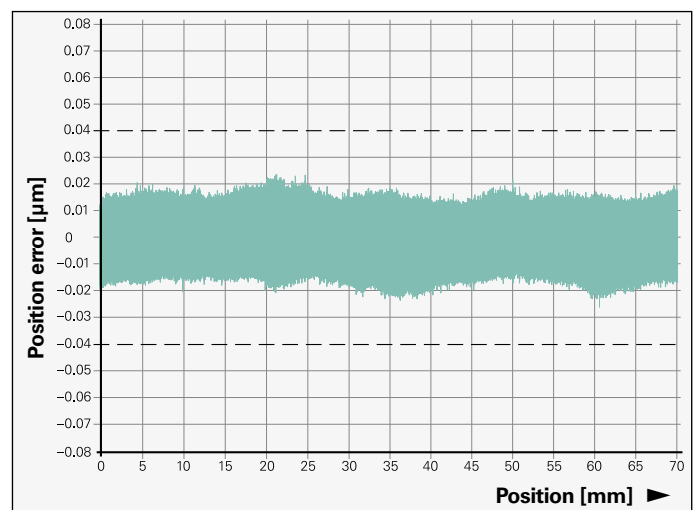
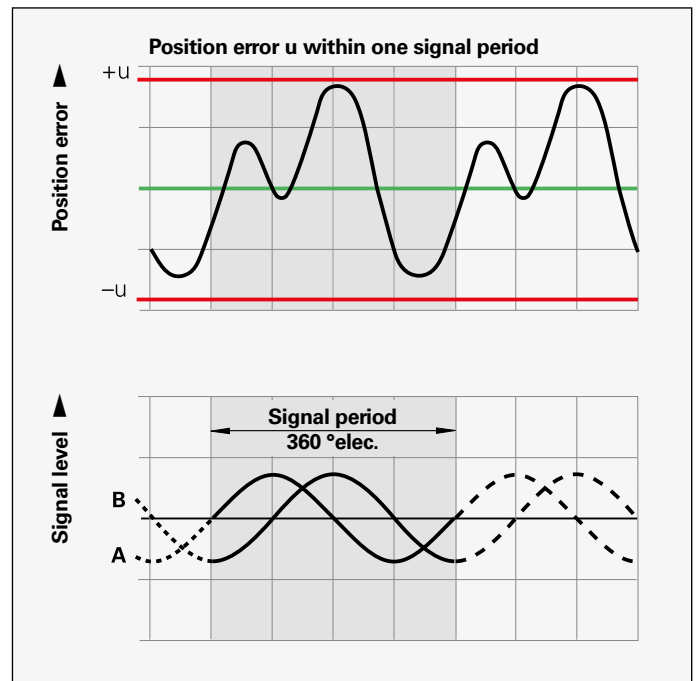
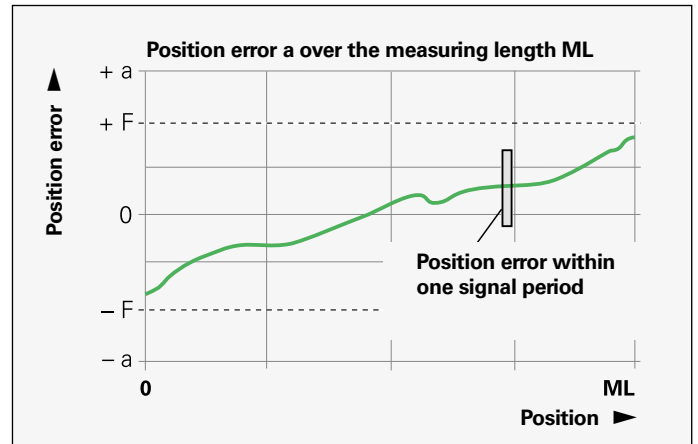

Position error within one signal period for a measuring range of 70 mm for LF encoders

	Signal period of the scanning signals	Max. position error u within one signal period
LF	4 µm	$\pm 0.04 \mu\text{m}$
LC 100 LC 400	20 µm	$\pm 0.1 \mu\text{m}$
LC 200	40 µm	$\pm 0.4 \mu\text{m}$
LS	20 µm	$\pm 0.2 \mu\text{m}$
LB	40 µm	$\pm 0.8 \mu\text{m}$

All HEIDENHAIN linear encoders are inspected before shipping for positioning accuracy and proper function.

The position errors are measured by traversing in both directions, and the averaged curve is shown in the calibration chart.

The **Quality Inspection Certificate** confirms the specified system accuracy of each encoder. The **calibration standards** ensure the traceability—as required by EN ISO 9001—to recognized national or international standards.

For the LC, LF and LS series listed in this brochure, a calibration chart documents the **position error** ascertained for the measuring length. It also indicates the measuring parameters and the uncertainty of the calibration measurement.

Temperature range

The linear encoders are inspected at a **reference temperature** of 20 °C. The system accuracy given in the calibration chart applies at this temperature.

The operating temperature range

indicates the ambient temperature limits between which the linear encoders will function properly.

The **storage temperature range** of -20 °C to +70 °C applies for the unit in its packaging. Starting from a measuring length of 3240 mm, the permissible storage temperature range for encoders of the LC 1x5 encoders is limited to -10 °C to +50 °C.



HEIDENHAIN

Qualitätsprüf-Zertifikat
DIN 55 350-18-4.2.2

Quality Inspection Certificate
DIN 55 350-18-4.2.2

LC 415
ID 689677-19
SN 37305486 A

Positionsabweichung F [µm]
Position error F [µm]

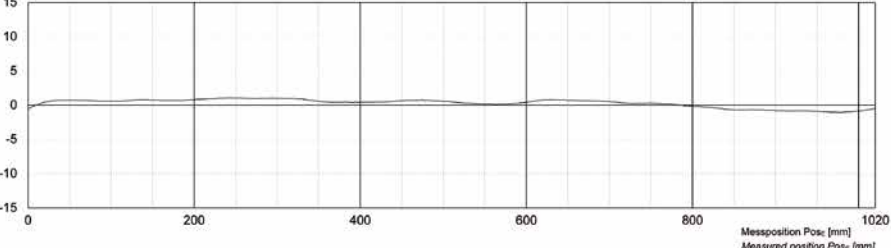

Messposition Pos_z [mm]
Measured position Pos_z [mm]

Die Messkurve zeigt die Mittelwerte der Positionsabweichungen aus Vorwärts- und Rückwärtsmessung.

Positionsabweichung F des Längenmessgerätes: $F = Pos_{zu} - Pos_z$
 Pos_{zu} = Messposition der Messmaschine
 Pos_z = Messposition des Längenmessgerätes

Maximale Positionsabweichung der Messkurve	
innerhalb 1000 mm	± 1,06 µm

Unsicherheit der Messmaschine	
$U_{95\%} = 0,2 \mu\text{m} + 0,6 \cdot 10^{-4} \cdot L$ (L=Länge Messintervall)	

Messparameter	
Messschritt	1000 µm
Relative Luftfeuchtigkeit	max. 50%

The error curve shows the mean values of the position errors from measurements in forward and backward direction.

Position error F of the linear encoder: $F = Pos_{zu} - Pos_z$
 Pos_{zu} = position measured by the measuring machine
 Pos_z = position measured by the linear encoder

Maximum position error of the error curve	
within 1000 mm	± 1.06 µm

Uncertainty of the measuring machine	
$U_{95\%} = 0.2 \mu\text{m} + 0.6 \cdot 10^{-4} \cdot L$ (L=measurement interval length)	

Measurement parameters	
Measurement step	1000 µm
Relative humidity	max. 50%

Dieses Längenmessgerät wurde unter strengen HEIDENHAIN-Qualitätsnormen hergestellt und geprüft. Die Positionsabweichung liegt bei einer Bezugstemperatur von 20 °C innerhalb der Genauigkeitsklasse ± 5,0 µm/m.

Kalibriernormale	Kalibrierzeichen
Jod stabilisierter He-Ne Laser	40151 PTB 11
Wasser-Tripelpunktzelle	61 PTB 10
Gallium-Schmelzpunktzelle	62 PTB 10
Barometer	6277 DKD-K-02301 10-06
Luftfeuchtemessgerät	05294 DKD-K-00305 10-06

This linear encoder has been manufactured and inspected in accordance with the stringent quality standards of HEIDENHAIN. The position error at a reference temperature of 20 °C lies within the accuracy grade ± 5.0 µm/m.

Calibration standards	Calibration references
Iodine-stabilized He-Ne Laser	40151 PTB 11
Water triple point cell	61 PTB 10
Gallium melting point cell	62 PTB 10
Pressure gauge	6277 DKD-K-02301 10-06
Hygrometer	05294 DKD-K-00305 10-06

DR. JOHANNES HEIDENHAIN GmbH · 83301 Traunreut · www.heidenhain.de · Telefon: +49 (8669) 31-0 · Fax: +49 (8669) 5061

19.03.2012
Prüfer/inspected by  V. dos Santos

Example

Mechanical design types and mounting guidelines

Linear encoders with small cross section

The LC, LF and LS slimline linear encoders should be fastened to a machined surface over their entire length, especially for highly dynamic requirements. Larger measuring lengths and higher vibration loads are made possible by using mounting spars or clamping elements (only for LC 4x5).

The slimline linear encoders feature identical mounting dimensions. This makes it possible, for example, to exchange an incremental LS or LF against an absolute LC on a specific machine design (please note the 20 µm smaller measuring length of the LF than the LC and LS). In addition, the same mounting spars can also be used regardless of the encoder product family (LC, LF or LS).

The encoder is mounted so that the sealing lips are directed downward or away from splashing water (also see *General Mechanical Information*).

Thermal characteristics

Because they are rigidly fastened using two M8 screws, the linear encoders largely adapt themselves to the mounting surface. When fastened over the mounting spar, the encoder is fixed at its midpoint to the mounting surface. The flexible fastening elements ensure reproducible thermal behavior.

The **LF 485** with its graduation carrier of steel has the same coefficient of thermal expansion as a mounting surface of gray cast iron or steel.

Mounting

It is surprisingly simple to mount the sealed linear encoders from HEIDENHAIN: You need only align the scale unit at several points along the machine guideway. Stop surfaces or stop pins can also be used for this. The shipping brace already sets the proper gap between the scale unit and the scanning unit, as well as the lateral tolerance. If the shipping brace needs to be removed before mounting due to a lack of space, then the mounting gauge is used to set the gap between the scale unit and the scanning unit easily and exactly. Lateral tolerances must also be maintained.

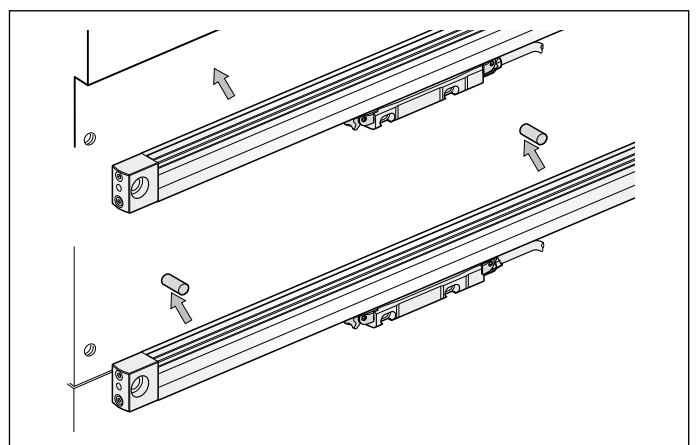
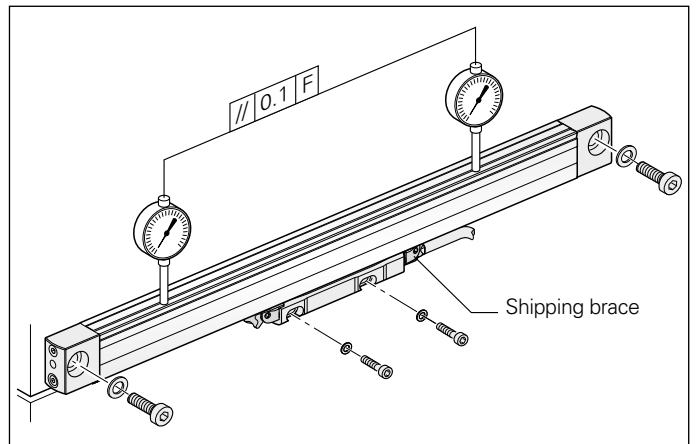
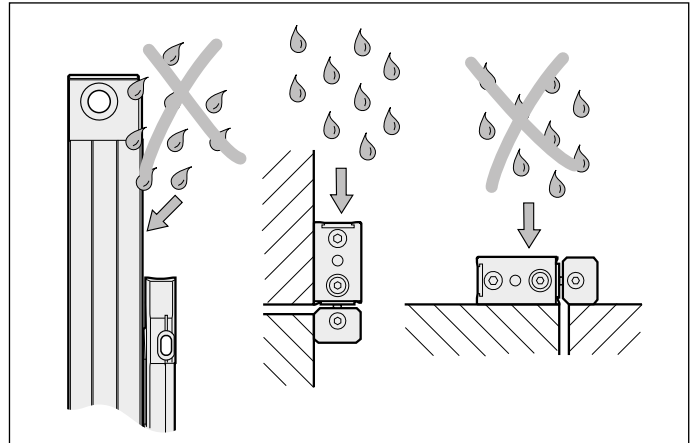

Accessories:

Mounting and test gauges for slimline linear encoders

The **mounting gauge** is used to set the gap between the scale unit and the scanning unit if the shipping brace needs to be removed before mounting. The **test gauges** are used to quickly and easily check the gap of the mounted linear encoder.

Along with the standard procedure of using two M8 screws to mount the scale unit on a plane surface, there are also other mounting possibilities:

Installation with mounting spar

Mounting the encoder with a mounting spar can be especially beneficial. It can be fastened as part of the machine assembly process. The encoder is then simply clamped on during final mounting. Easy exchange also facilitates servicing. A mounting spar is recommended for highly-dynamic applications with measuring lengths greater than 620 mm. It is always necessary for measuring lengths starting from 1240 mm.

For the **MSL 41 mounting spar**, the components necessary for clamping are premounted. It is designed for linear encoders with normal or short end blocks. The LC 4x5, LF 4x5 and LS 4x7 can be mounted by either side to enable a cable outlet at either end. The MSL 41 mounting spar must be ordered separately.

The **mounting aid** is locked onto the mounted spar and therefore simulates an optimally mounted scanning unit. The customer's fastening for the scanning unit can be easily aligned to it. Then the mounting aid is replaced by the linear encoder.

Accessories:

MSL 41 mounting spar

ID 770902-xx

Mounting aid for scanning unit

ID 753853-01

Mounting with clamping elements

The scale unit of the LC 4x5 is fastened at both ends. In addition, it can also be attached to the mounting surface by clamping elements. For measuring lengths over 1240 mm this makes it easy and reliable to mount the encoder without a spar and fasten it at the center of the measuring length (recommended for highly-dynamic applications with ML greater than 620 mm).

Accessory:

Clamping elements

With pin and M5x10 screw

ID 556975-01 (10 units per package)

	x	Color	ID
Mounting gauge	1.0 mm	Gray	737748-01
Test gauge max.	1.3 mm	Red	737748-02
Test gauge min.	0.7 mm	Blue	737748-03

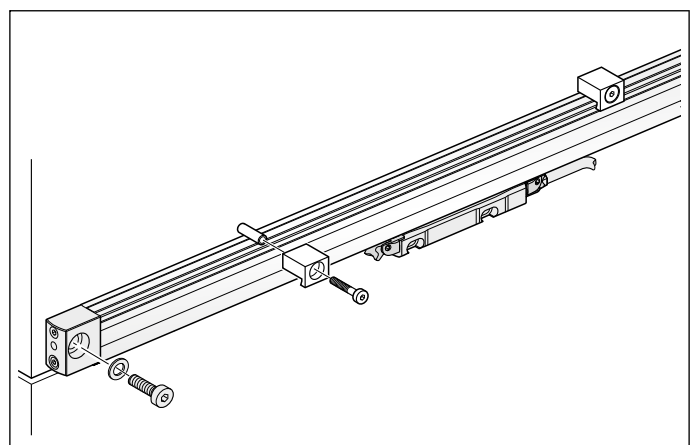
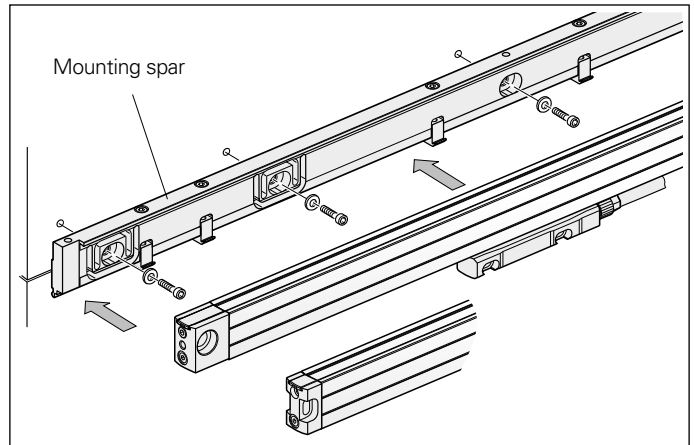
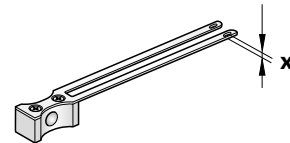

Linear encoders with large cross section

The LB, LC, LF and LS full-size linear encoders are fastened over their entire length onto a machined surface. This gives them a **high vibration rating**. The oblique arrangement of the sealing lips permits **universal mounting** with vertical or horizontal scale housing with equally high protection rating.

The LC 1x5 features an optimized sealing system with two successive pairs of sealing lips. When cleaned compressed air is introduced into the scale housing, it effectively seals the two pairs of sealing lips against ambient air. This optimally protects the interior of the encoder from contamination.

The flow rate is set through a connecting piece with integrated throttle (see separate accessories under *Protection* on page 18).

Thermal characteristics

The thermal behavior of the LB, LC, LF and LS 100 linear encoders with large cross section has been optimized:

On the **LF**, the steel scale is cemented to a steel carrier that is fastened directly to the machine element.

On the **LB**, the steel scale tape is clamped directly onto the machine element. The LB therefore takes part in all thermal changes of the mounting surface.

The **LC** and **LS** are fixed to the mounting surface at their midpoint. The flexible fastening elements permit reproducible thermal behavior.

Mounting

It is surprisingly simple to mount the sealed linear encoders from HEIDENHAIN: You need only align the scale unit at several points along the machine guideway. Stop surfaces or stop pins can also be used for this. The shipping brace already sets the proper gap between the scale unit and the scanning unit. The lateral gap is to be set during mounting. If the shipping brace needs to be removed before mounting due to a lack of space, then the mounting gauge is used to set the gap between the scale unit and the scanning unit exactly. Lateral tolerances must also be maintained.

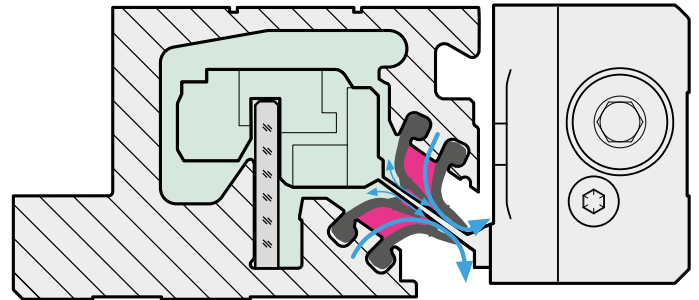

Sealing system of the LC 1x5

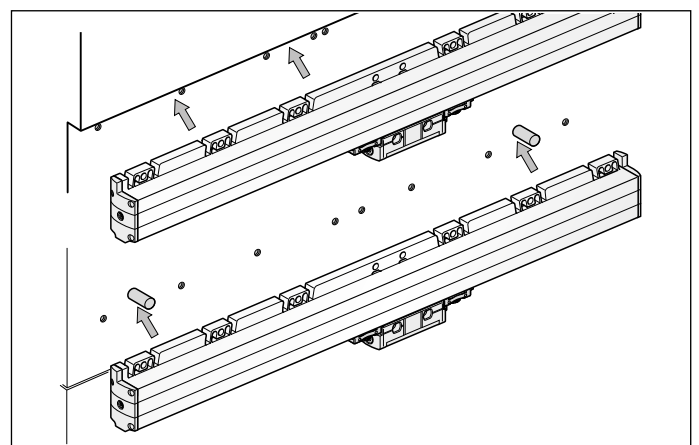
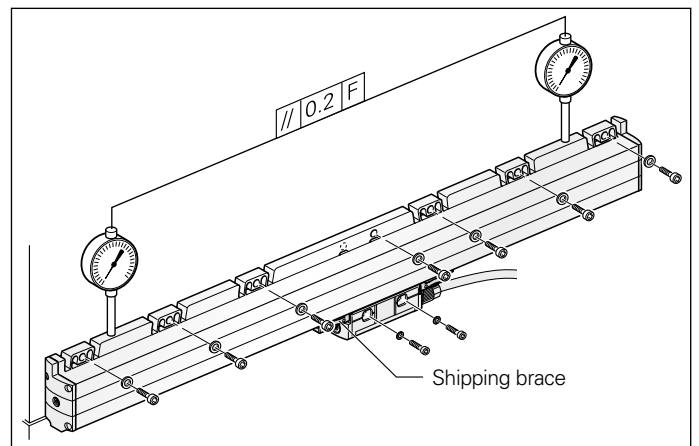
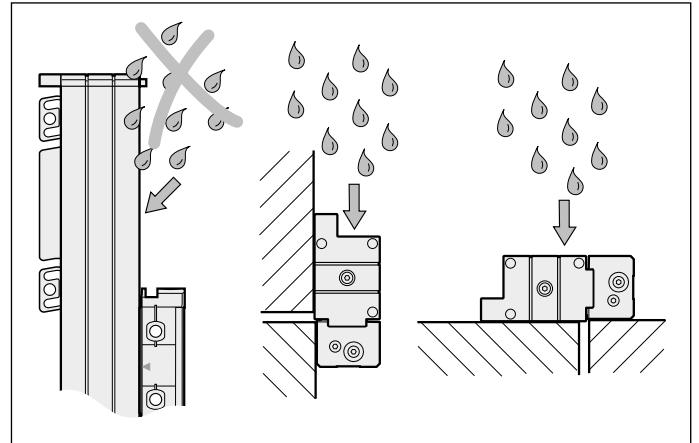

Mounting the multi-section LC 2x1 and LB 382

The LC 2x1 and LB 382 with measuring lengths over 3240 mm are mounted on the machine in individual sections:

- Mount and align the individual housing sections
- Pull in the scale tape over the entire length and tension it
- Pull in the sealing lips
- Insert the scanning unit

Adjustment of the scale tape tension enables linear machine error compensation up to $\pm 100 \mu\text{m/m}$.

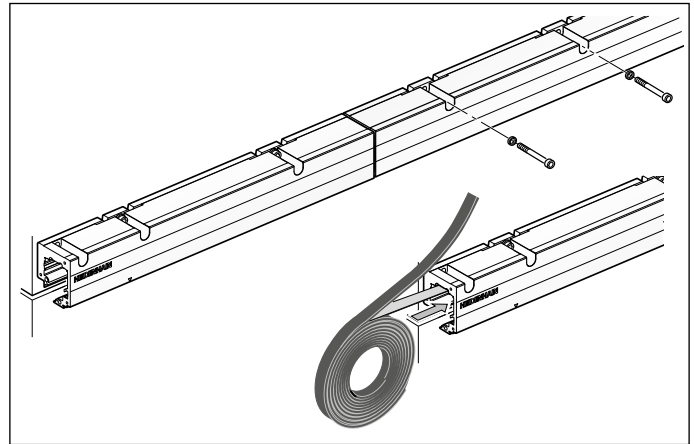

Accessory:

Mounting aids

For LC 1x3, LS 1x7 ID 547793-02

For LC 1x5 ID 1067589-02

The mounting aid is locked onto the scale unit, simulating an optimally adjusted scanning unit. The customer's fastening for the scanning unit can be easily aligned to it. The mounting aid is then removed and the scanning unit is attached to the mounting bracket.

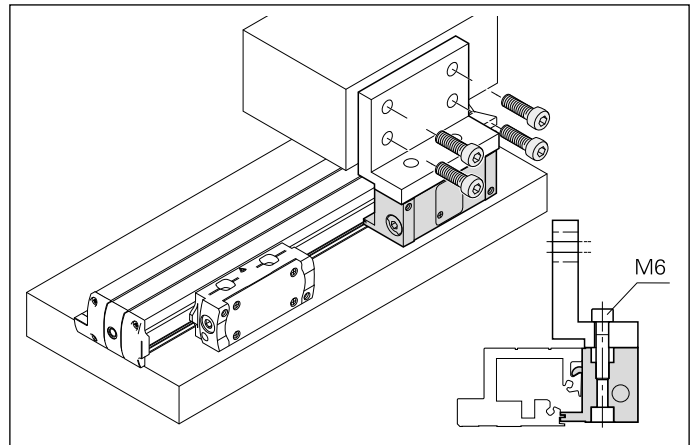

Example

LC, LS	x	Color	ID
Mounting gauge	1.5 mm	Gray	575832-01
Test gauge max.	1.8 mm	Red	575832-02
Test gauge min.	1.2 mm	Blue	575832-03

LB 382/LC 2x1	x	Color	ID
Mounting gauge	1.0 mm	Gray	772141-01
Test gauge max.	1.3 mm	Red	772141-02
Test gauge min.	0.7 mm	Blue	772141-03

Accessory:

Mounting and test gauges for full-size linear encoders

The **mounting gauge** is used to set the gap between the scale unit and the scanning unit if the shipping brace needs to be removed before mounting. The **test gauges** are used to quickly and easily check the gap of the mounted linear encoder.

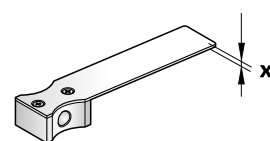

General mechanical information

Protection

Sealed **linear encoders** fulfill the requirements for IP 53 protection according to **EN 60529** or **IEC 60529** provided that they are mounted with the sealing lips facing away from splash water. If necessary, provide a separate protective cover. If the encoder is exposed to particularly heavy concentrations of coolant and mist, **compressed air** can be used to provide **IP 64** protection to more effectively prevent the ingress of contamination. To apply the pressurized air for sealing the housing, the LB, LC, LF and LS sealed linear encoders are therefore equipped with inlets at both end pieces and on the mounting block of the scanning unit.

The compressed air introduced directly onto the encoders must be cleaned by a micro filter, and must comply with the following quality classes as per **ISO 8573-1** (2010 edition):

- Solid contaminants: **Class 1**
Particle size
0.1 µm to 0.5 µm ≤ 20000
0.5 µm to 1.0 µm ≤ 400
1.0 µm to 5.0 µm ≤ 10
- Max. pressure dew point: **Class 4**
(pressure dew point at 3 °C)
- Total oil content: **Class 1**
(max. oil concentration: 0.01 mg/m³)

For optimum supply of sealing air to the sealed linear encoders, the required air flow is 7 to 10 l/min per encoder. Ideally the air flow is regulated by the HEIDENHAIN connecting pieces with integrated throttle (see *Accessories*). At an inlet pressure of approx. $1 \cdot 10^5$ Pa (1 bar), the throttles ensure the prescribed volume of airflow.

Accessories:

Connecting piece, straight

With throttle and gasket
ID 226270-xx

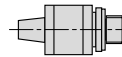

Connecting piece, straight, short

With throttle and gasket
ID 275239-xx

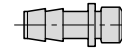

Also suitable:

Swiveling screw fitting 90°

With seal
ID 207834-xx



Accessory:

DA 400 compressed air unit

ID 894602-01

DA 400

HEIDENHAIN offers the DA 400 compressed-air filter system for purifying the compressed air. It is designed specifically for the introduction of compressed air into encoders.

The DA 400 consists of three filter stages (prefilter, fine filter and activated carbon filter) and a pressure regulator with pressure gauge. The pressure gauge and the automatic pressure switch (which is available as an accessory) effectively monitor the sealing air.

The compressed air introduced into the DA 400 must fulfill the requirements of the following purity classes as per **ISO 8573-1** (2010 edition):

- Solid contaminants: **Class 5**
Particle size
0.1 µm to 0.5 µm Not specified
0.5 µm to 1.0 µm Not specified
1.0 µm to 5.0 µm ≤ 100000
- Max. pressure dew point: **Class 6**
(pressure dew point at 10 °C)
- Total oil content: **Class 4**
(max. oil concentration: 5 mg/m³)



DA 400

For more information, ask for our *DA 400* Product Information Sheet.

Mounting

To simplify cable routing, the mounting block of the scanning unit is usually screwed onto a stationary machine part, and the scale housing on the moving part. The **mounting location** for the linear encoders should be carefully considered in order to ensure both optimum accuracy and the longest possible service life.

- The encoder should be mounted as closely as possible to the working plane to keep the Abbe error small.
- To function properly, linear encoders must not be continuously subjected to strong vibration; the more solid parts of the machine tool provide the best mounting surface in this respect. Encoders should not be mounted on hollow parts or with adapters. A mounting spar is recommended for sealed linear encoders with small cross section.
- Linear encoders should be mounted away from sources of heat to avoid temperature influences.

Acceleration

Linear encoders are subjected to various types of acceleration during operation and mounting.

- The indicated maximum values for **vibration** apply for frequencies of 55 to 2000 Hz (**EN 60068-2-6**), except when mechanical resonance arises. **Comprehensive tests of the entire system are required.**
- The maximum permissible acceleration values (semi-sinusoidal shock) for **shock and impact** are valid for 11 ms (**EN 60068-2-27**). Under no circumstances should a hammer or similar implement be used to adjust or position the encoder.

Required moving force

The required moving force stated is the maximum force required to move the scale unit relative to the scanning unit.

RoHS

HEIDENHAIN has tested the products for harmlessness of the materials as per European Directives 2002/95/EC (RoHS) and 2002/96/EC (WEEE). For a Manufacturer's Declaration on RoHS, please refer to your sales agency.

Expendable parts

HEIDENHAIN encoders contain components that are subject to wear, depending on the application and handling. These include in particular the following parts:

- LED light source
 - Cables with frequent flexing
- Additionally for encoders with integral bearing:
- Bearing
 - Shaft sealing rings for rotary and angular encoders
 - Sealing lips for sealed linear encoders

System tests

Encoders from HEIDENHAIN are usually integrated as components in larger systems. Such applications require **comprehensive tests of the entire system** regardless of the specifications of the encoder.

The specifications shown in this brochure apply to the specific encoder, and not to the entire system. Any operation of the encoder outside of the specified range or for any other than the intended applications is at the user's own risk.

Assembly

Work steps to be performed and dimensions to be maintained during mounting are specified solely in the mounting instructions supplied with the unit. All data in this catalog regarding mounting are therefore provisional and not binding; they do not become terms of a contract.

DIADUR, AURODUR and METALLUR are registered trademarks of DR. JOHANNES HEIDENHAIN GmbH, Traunreut, Germany. DRIVE-CLiQ is a registered trademark of SIEMENS Aktiengesellschaft

LC 400 series

Absolute linear encoders with slimline scale housing

- For limited installation space
- Identical dimensions for LC 415/LC 485/LC 495

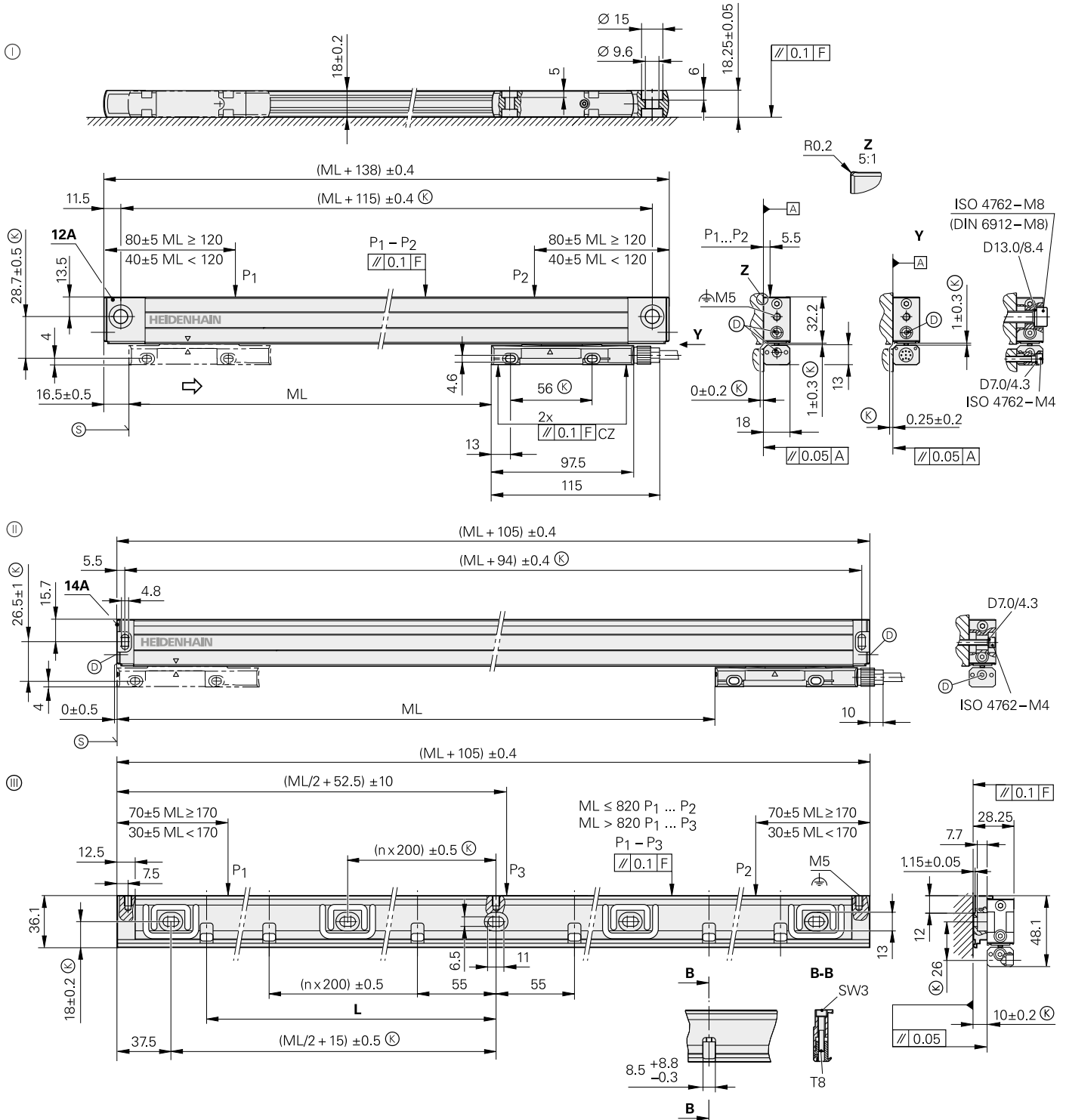

ML	70	120	170	220	270	320	370	420	470	520	570	620	670	720	770	820	920	1020	1140	1240	1340	1440	1540	1640	1740	1840	2040
L	37.5	55	75	100	115	140	175	200	225	250	275	300	325	350	375	400	450	500	555	610	655	710	760	810	855	910	1010

mm

Tolerancing ISO 8015
ISO 2768 - m H
< 6 mm: ± 0.2 mm

- ⊙ = End block 12A; for mounting with and without mounting spar
- ⊙ = End block 14A; for mounting with mounting spar (specifications are restricted if attached directly with M4 screws)
- ⊙ = Mounting spar MSL 41
- F = Machine guideway
- P = Gauging points for alignment
- ⊙ = Required mating dimensions
- ⊙ = Inlet for compressed air
- ⊙ = Beginning of measuring length ML (= 20 mm absolute)
- ⇒ = Direction of scanning unit motion for output signals in accordance with interface description



Specifications	LC 415	LC 485
Measuring standard Coefficient of linear expansion	DIADUR glass scale with absolute track and incremental track, grating period 20 µm $\alpha_{\text{therm}} \approx 8 \times 10^{-6} \text{ K}^{-1}$ (mounting type ①/②); <i>with mounting spar</i> : $\alpha_{\text{therm}} \approx 9 \times 10^{-6} \text{ K}^{-1}$ (mounting type ③)	
Accuracy grade*	± 3 µm; ± 5 µm	
Measuring length ML* in mm	Mounting spar* or clamping elements* up to ML 1240 optional, necessary as of ML 1340 70 120 170 220 270 320 370 420 470 520 570 620 670 720 770 820 920 1020 1140 1240 1340 1440 1540 1640 1740 1840 2040	
Functional safety*	Option ¹⁾	–
Interface	EnDat 2.2	
Ordering designation	EnDat22	EnDat02
Resolution <i>At ± 3 µm</i> <i>At ± 5 µm</i>	0.001 µm 0.010 µm	0.005 µm 0.010 µm
Diagnostics interface	Digital	
Clock frequency Calculation time t_{cal}	≤ 16 MHz ≤ 5 µs	≤ 2 MHz ≤ 5 µs
Incremental signals	–	~ 1 V _{PP}
Signal period Cutoff frequency –3 dB	–	20 µm ≥ 150 kHz
Electrical connection	Separate adapter cable (1 m/3 m/6 m/9 m) connectible to mounting block	
Cable length	≤ 100 m ²⁾	≤ 150 m ²⁾
Voltage supply	3.6 V to 14 V DC	
Power consumption (max.)	3.6 V: ≤ 1.1 W; 14 V: ≤ 1.3 W	
Current consumption (typical)	5 V: 140 mA (without load)	
Traversing speed	≤ 180 m/min	
Required moving force	≤ 5 N	
Vibration 55 to 2000 Hz affecting the	<i>Scanning unit</i> : ≤ 200 m/s ² (EN 60068-2-6) <i>Housing without mounting spar</i> : ≤ 100 m/s ² (EN 60068-2-6) <i>Housing with mounting spar, and cable outlet at right</i> : ≤ 150 m/s ² , <i>at left</i> : ≤ 100 m/s ² (EN 60068-2-6)	
Shock 11 ms Acceleration	≤ 300 m/s ² (EN 60068-2-27) ≤ 100 m/s ² in measuring direction	
Operating temperature	0 °C to +50 °C	
Protection EN 60529	IP 53 when installed according to instructions in the brochure, IP 64 with sealing air from DA 400	
Weight	<i>Encoder</i> : 0.2 kg + 0.55 kg/m measuring length; <i>mounting spar</i> : 0.9 kg/m	

* Please indicate when ordering ¹⁾ For dimensions and specifications, see separate Product Information document

²⁾ With HEIDENHAIN cable, clock frequency ≤ 8 MHz

LC 400 series

Absolute linear encoders with slimline scale housing

- For limited installation space
- Identical dimensions for LC 415/LC 485/LC 495

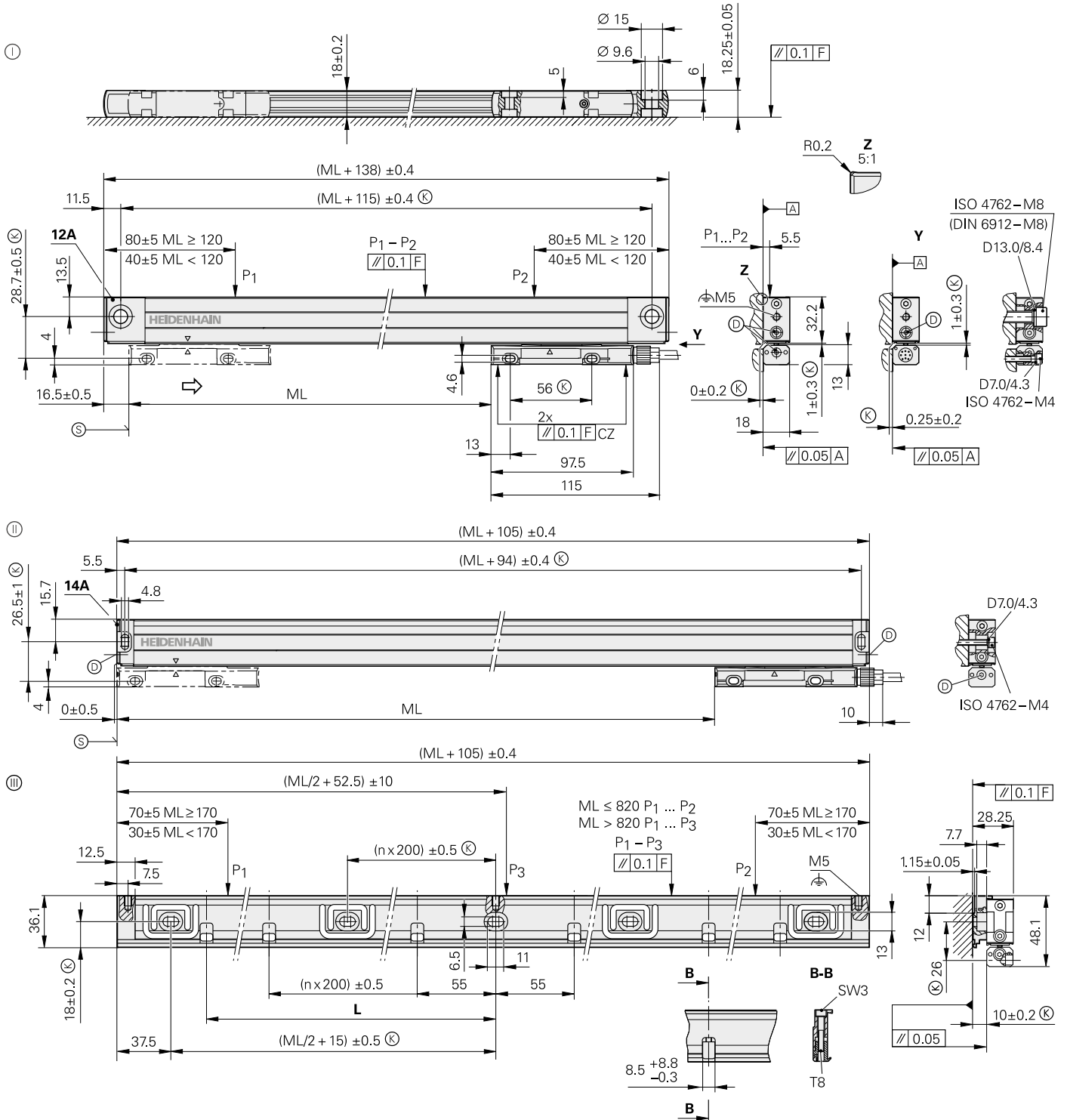

ML	70	120	170	220	270	320	370	420	470	520	570	620	670	720	770	820	920	1020	1140	1240	1340	1440	1540	1640	1740	1840	2040
L	37.5	55	75	100	115	140	175	200	225	250	275	300	325	350	375	400	450	500	555	610	655	710	760	810	855	910	1010

mm

 Tolerancing ISO 8015
 ISO 2768 - m H
 < 6 mm: ±0.2 mm

- ⊙ = End block 12A; for mounting with and without mounting spar
- ⊙ = End block 14A; for mounting with mounting spar (specifications are restricted if attached directly with M4 screws)
- ⊙ = Mounting spar MSL 41
- F = Machine guideway
- P = Gauging points for alignment
- ⊙ = Required mating dimensions
- ⊙ = Inlet for compressed air
- ⊙ = Beginning of measuring length ML (= 20 mm absolute)
- ⇒ = Direction of scanning unit motion for output signals in accordance with interface description



Specifications	LC 495 F	LC 495 M	LC 495 S
Measuring standard Coefficient of linear expansion	DIADUR glass scale with absolute track and incremental track, grating period 20 µm $\alpha_{\text{therm}} \approx 8 \times 10^{-6} \text{ K}^{-1}$ (mounting type ①/②); with mounting spar: $\alpha_{\text{therm}} \approx 9 \times 10^{-6} \text{ K}^{-1}$ (mounting type ③)		
Accuracy grade*	± 3 µm; ± 5 µm		
Measuring length ML* in mm	Mounting spar* or clamping elements* up to ML 1240 optional, necessary as of ML 1340 70 120 170 220 270 320 370 420 470 520 570 620 670 720 770 820 920 1020 1140 1240 1340 1440 1540 1640 1740 1840 2040		
Functional safety*	–		Option ¹⁾
Interface	Fanuc Serial Interface αi interface	Mitsubishi high speed interface	DRIVE-CLiQ
Ordering designation	Fanuc05	Mit03-04	DQ01
Resolution At ± 3 µm At ± 5 µm	αi interface/α interface 0.00125 µm/0.010 µm 0.0125 µm/0.050 µm	0.001 µm 0.010 µm	
Diagnostics interface	Digital		
Electrical connection	Separate adapter cable (1 m/3 m/6 m/9 m) connectible to mounting block		
Cable length	≤ 50 m	≤ 30 m	≤ 30 m ²⁾
Voltage supply	3.6 V to 14 V DC		10 V to 28.8 V DC
Power consumption (max.)	3.6 V: ≤ 1.1 W; 14 V: ≤ 1.3 W		10 V: ≤ 1.5 W; 28.8 V: ≤ 1.7 W
Current consumption (typical)	5 V: 140 mA (without load)		24 V: 46 mA (without load)
Traversing speed	≤ 180 m/min		
Required moving force	≤ 5 N		
Vibration 55 to 2000 Hz affecting the	Scanning unit: ≤ 200 m/s ² (EN 60068-2-6) Housing without mounting spar: ≤ 100 m/s ² (EN 60068-2-6) Housing with mounting spar, and cable outlet at right: ≤ 150 m/s ² , at left: ≤ 100 m/s ² (EN 60068-2-6)		
Shock 11 ms Acceleration	≤ 300 m/s ² (EN 60068-2-27) ≤ 100 m/s ² in measuring direction		
Operating temperature	0 °C to +50 °C		
Protection EN 60529	IP 53 when installed according to instructions in the brochure, IP 64 with sealing air from DA 400		
Weight	Encoder: 0.2 kg + 0.55 kg/m measuring length; mounting spar: 0.9 kg/m		

* Please select when ordering

¹⁾ For dimensions and specifications, see separate Product Information document

²⁾ Greater cable lengths in preparation

LC 100 series

Absolute linear encoders with full-size scale housing

- High vibration resistance
- Reclining mounting possible
- High reliability through double sealing lips
- Identical dimensions for LC 115/LC 185/LC 195

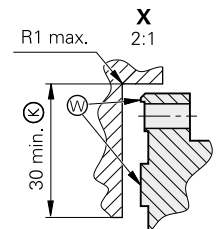
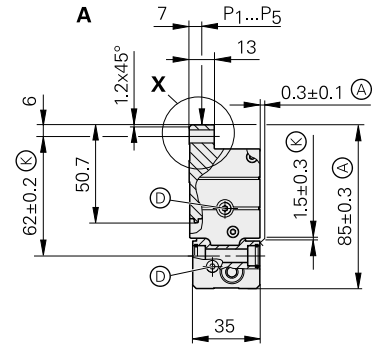
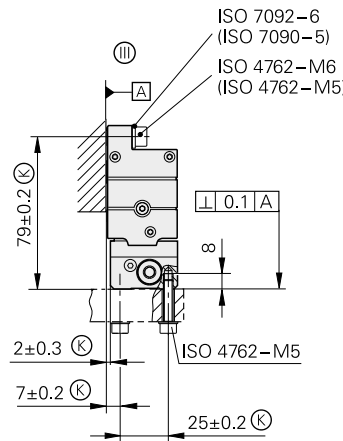
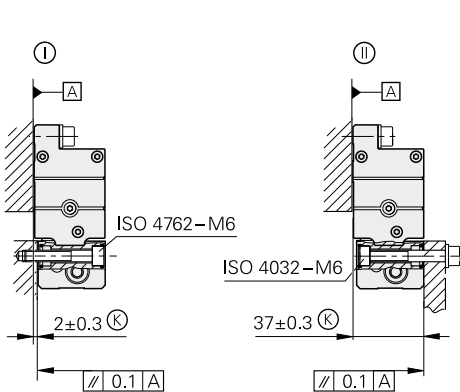
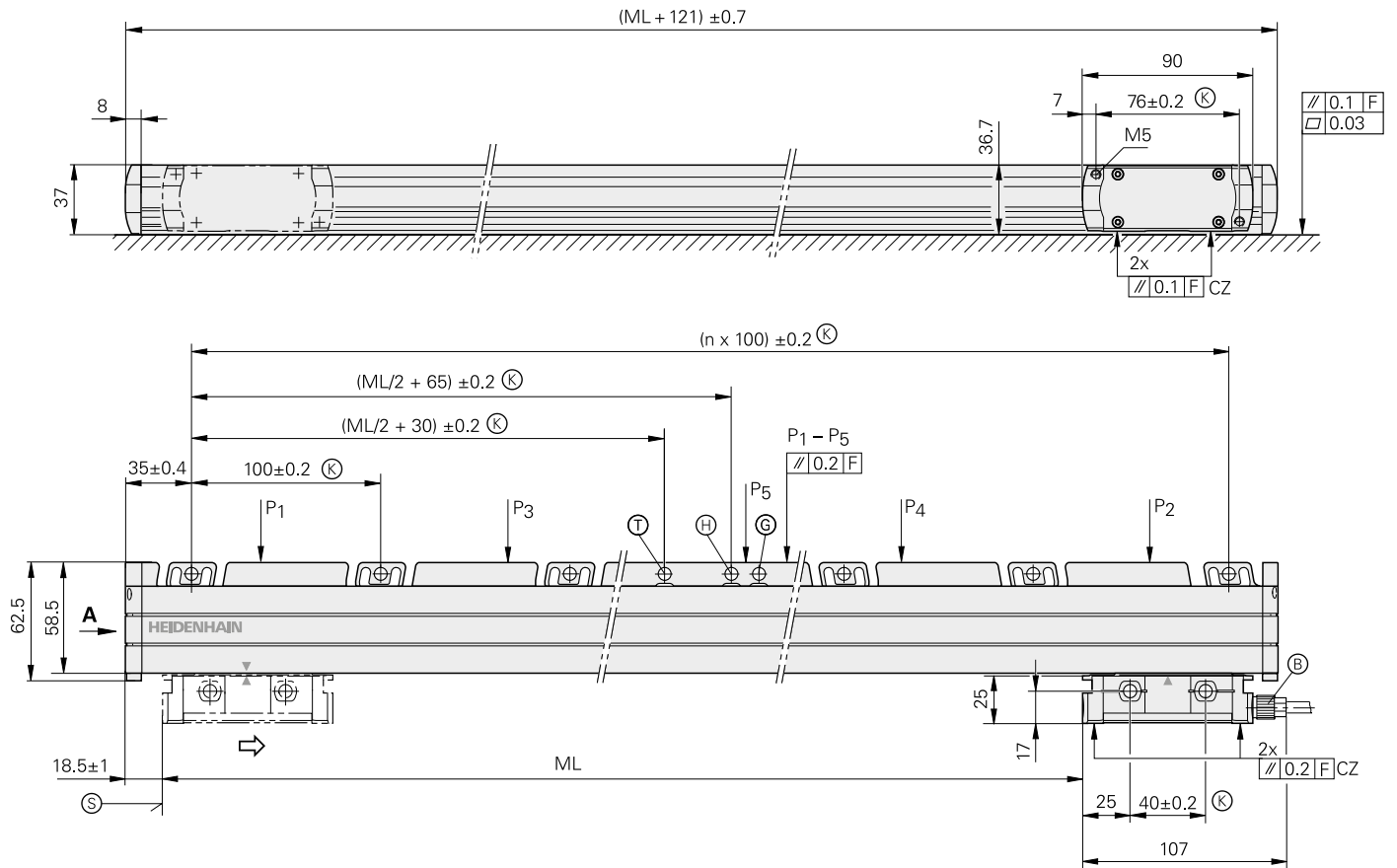

mm
 Tolerancing ISO 8015
 ISO 2768 - m H
 < 6 mm: ±0.2 mm

- Ⓛ, Ⓜ, = Mounting options
- F = Machine guideway
- P = Gauging points for alignment
- Ⓢ = Required mating dimensions
- Ⓐ = Alternative mating dimensions
- Ⓟ = Cable connection usable at either end
- Ⓠ = Compressed-air connection usable at either end
- Ⓡ = Mechanical fixed point (to be preferred)
- Ⓢ = Mechanical fixed point, compatible to predecessor model
- Ⓣ = Mechanical fixed point, with spacing interval of 100 mm
- Ⓤ = Beginning of measuring length ML (= 20 mm absolute)
- Ⓥ = Mating surfaces
- ⇒ = Direction of scanning unit motion for output signals in accordance with interface description



Specifications	LC 115	LC 185
Measuring standard Coefficient of linear expansion	DIADUR glass scale with absolute track and incremental track, grating period 20 µm $\alpha_{\text{therm}} \approx 8 \times 10^{-6} \text{ K}^{-1}$	
Accuracy grade*	± 3 µm up to measuring length 3040 mm; ± 5 µm	
Measuring length ML* in mm	140 240 340 440 540 640 740 840 940 1040 1140 1240 1340 1440 1540 1640 1740 1840 2040 2240 2440 2640 2840 3040 3240 3440 3640 3840 4040 4240	
Functional safety*	Option ¹⁾	–
Interface	EnDat 2.2	
Ordering designation	EnDat22	EnDat02
Resolution <i>At ± 3 µm</i> <i>At ± 5 µm</i>	0.001 µm 0.010 µm	0.005 µm 0.010 µm
Diagnostics interface	Digital	
Clock frequency Calculation time t_{cal}	≤ 16 MHz ≤ 5 µs	≤ 2 MHz ≤ 5 µs
Incremental signals	–	~ 1 V _{PP}
Signal period Cutoff frequency –3 dB	–	20 µm ≥ 150 kHz
Electrical connection	Separate adapter cable (1 m/3 m/6 m/9 m) connectable on both sides to mounting block	
Cable length	≤ 100 m ²⁾	≤ 150 m ²⁾
Voltage supply	3.6 V to 14 V DC	
Power consumption (max.)	3.6 V: ≤ 1.1 W; 14 V: ≤ 1.3 W	
Current consumption (typical)	5 V: 140 mA (without load)	
Traversing speed	≤ 180 m/min	
Required moving force	≤ 4 N	
Vibration 55 to 2000 Hz affecting the Shock 11 ms Acceleration	<i>Housing:</i> ≤ 200 m/s ² (EN 60068-2-6) <i>Scanning unit:</i> ≤ 200 m/s ² (EN 60068-2-6) ≤ 300 m/s ² (EN 60068-2-27) ≤ 100 m/s ² in measuring direction	
Operating temperature	0 °C to +50 °C	
Protection EN 60529	IP 53 when installed according to instructions in the brochure, IP 64 with sealing air from DA 400	
Weight	0.55 kg + 2.9 kg/m measuring length	

* Please indicate when ordering ¹⁾ For dimensions and specifications, see separate Product Information document

²⁾ With HEIDENHAIN cable, clock frequency ≤ 8 MHz

LC 100 series

Absolute linear encoders with full-size scale housing

- High vibration resistance
- Reclining mounting possible
- High reliability through double sealing lips
- Identical dimensions for LC 115/LC 185/LC 195

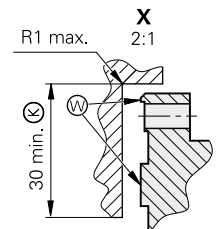
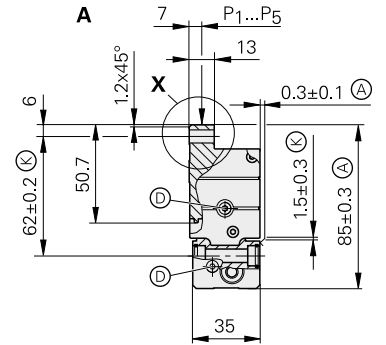
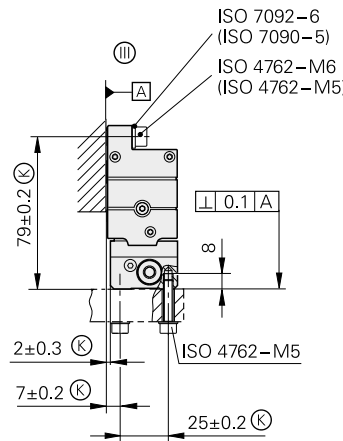
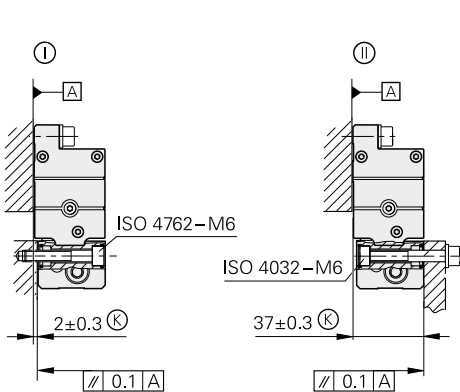
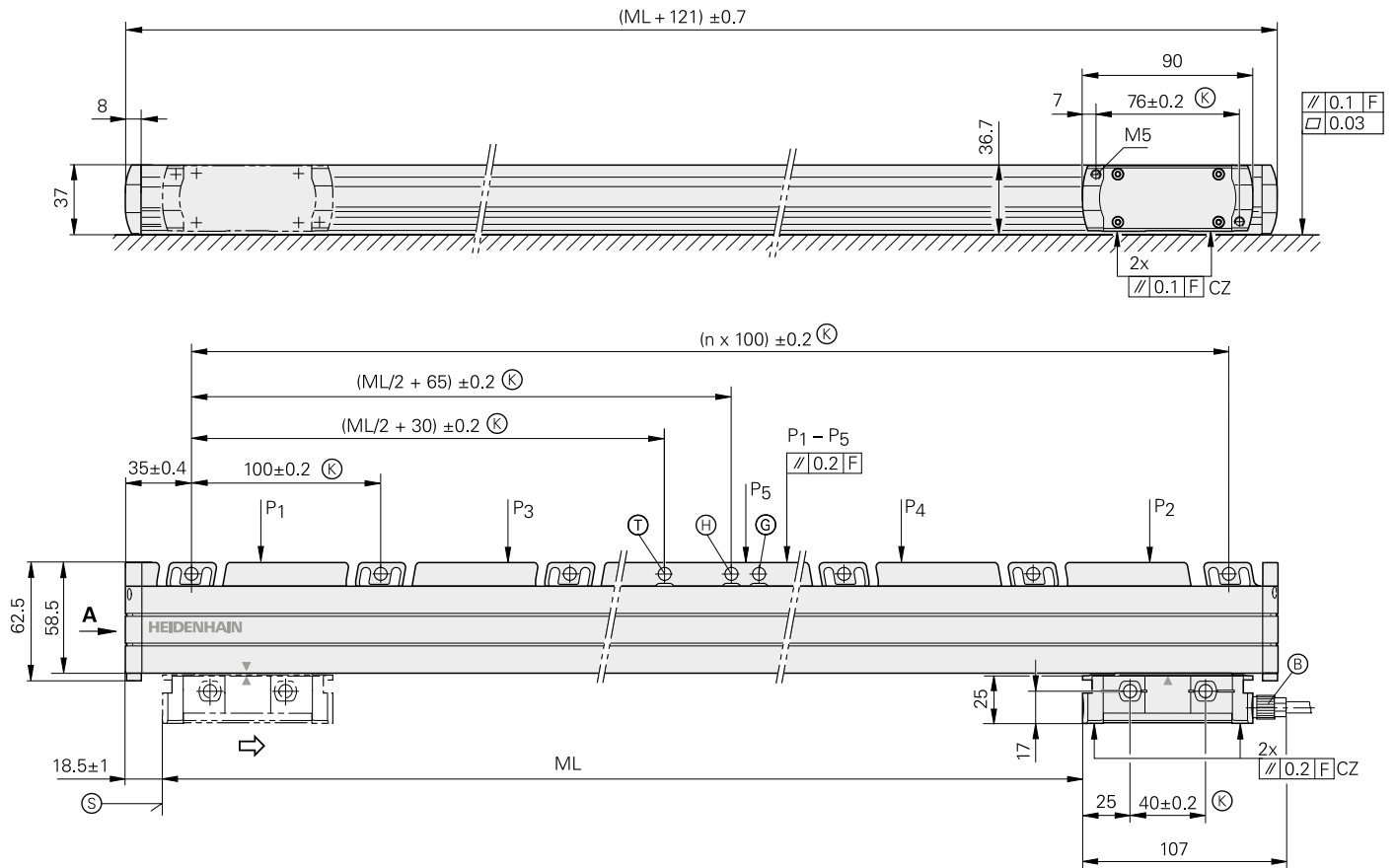

mm
 Tolerancing ISO 8015
 ISO 2768 - m H
 < 6 mm: ±0.2 mm

- Ⓚ, Ⓛ, Ⓜ, Ⓝ = Mounting options
- F = Machine guideway
- P = Gauging points for alignment
- Ⓞ = Required mating dimensions
- Ⓟ = Alternative mating dimensions
- Ⓠ = Cable connection usable at either end
- Ⓡ = Compressed-air connection usable at either end
- Ⓢ = Mechanical fixed point (to be preferred)
- Ⓣ = Mechanical fixed point, compatible to predecessor model
- Ⓤ = Mechanical fixed point, with spacing interval of 100 mm
- Ⓥ = Beginning of measuring length ML (= 20 mm absolute)
- Ⓦ = Mating surfaces
- ⇒ = Direction of scanning unit motion for output signals in accordance with interface description



Specifications	LC 195 F	LC 195 M	LC 195 S
Measuring standard Coefficient of linear expansion	DIADUR glass scale with absolute track and incremental track, grating period 20 µm $\alpha_{\text{therm}} \approx 8 \times 10^{-6} \text{ K}^{-1}$		
Accuracy grade*	± 3 µm up to measuring length 3040 mm; ± 5 µm		
Measuring length ML* in mm	140 1540 4040	240 1640 4240	340 440 540 640 740 840 940 1040 1140 1240 1340 1440 1740 1840 2040 2240 2440 2640 2840 3040 3240 3440 3640 3840
Functional safety*	–		Option ¹⁾
Interface	Fanuc Serial Interface α i interface	Mitsubishi high speed interface	DRIVE-CLiQ
Ordering designation	Fanuc05	Mit03-04	DQ01
Resolution <i>At ± 3 µm</i> <i>At ± 5 µm</i>	α i interface/ α interface 0.00125 µm/0.010 µm 0.0125 µm/0.050 µm	0.001 µm 0.010 µm	
Diagnostics interface	Digital		
Electrical connection	Separate adapter cable (1 m/3 m/6 m/9 m) connectable on both sides to mounting block		
Cable length	≤ 50 m	≤ 30 m	≤ 30 m ²⁾
Voltage supply	3.6 V to 14 V DC		10 V to 28.8 V DC
Power consumption (max.)	3.6 V: ≤ 1.1 W; 14 V: ≤ 1.3 W		10 V: ≤ 1.5 W; 28.8 V: ≤ 1.7 W
Current consumption (typical)	5 V: 140 mA (without load)		24 V: 46 mA (without load)
Traversing speed	≤ 180 m/min		
Required moving force	≤ 4 N		
Vibration 55 to 2000 Hz affecting the Shock 11 ms Acceleration	<i>Housing:</i> ≤ 200 m/s ² (EN 60068-2-6) <i>Scanning unit:</i> ≤ 200 m/s ² (EN 60068-2-6) ≤ 300 m/s ² (EN 60068-2-27) ≤ 100 m/s ² in measuring direction		
Operating temperature	0 °C to +50 °C		
Protection EN 60529	IP 53 when installed according to instructions in the brochure, IP 64 with sealing air from DA 400		
Weight	0.55 kg + 2.9 kg/m measuring length		

* Please select when ordering

¹⁾ For dimensions and specifications, see separate Product Information document

²⁾ Greater cable lengths in preparation

LC 200 series

Absolute linear encoders with full-size scale housing

- Measuring lengths up to 28 m
- Simplified mounting (upright or reclining)
- Also available in mirrored version (mating dimensions upon request)

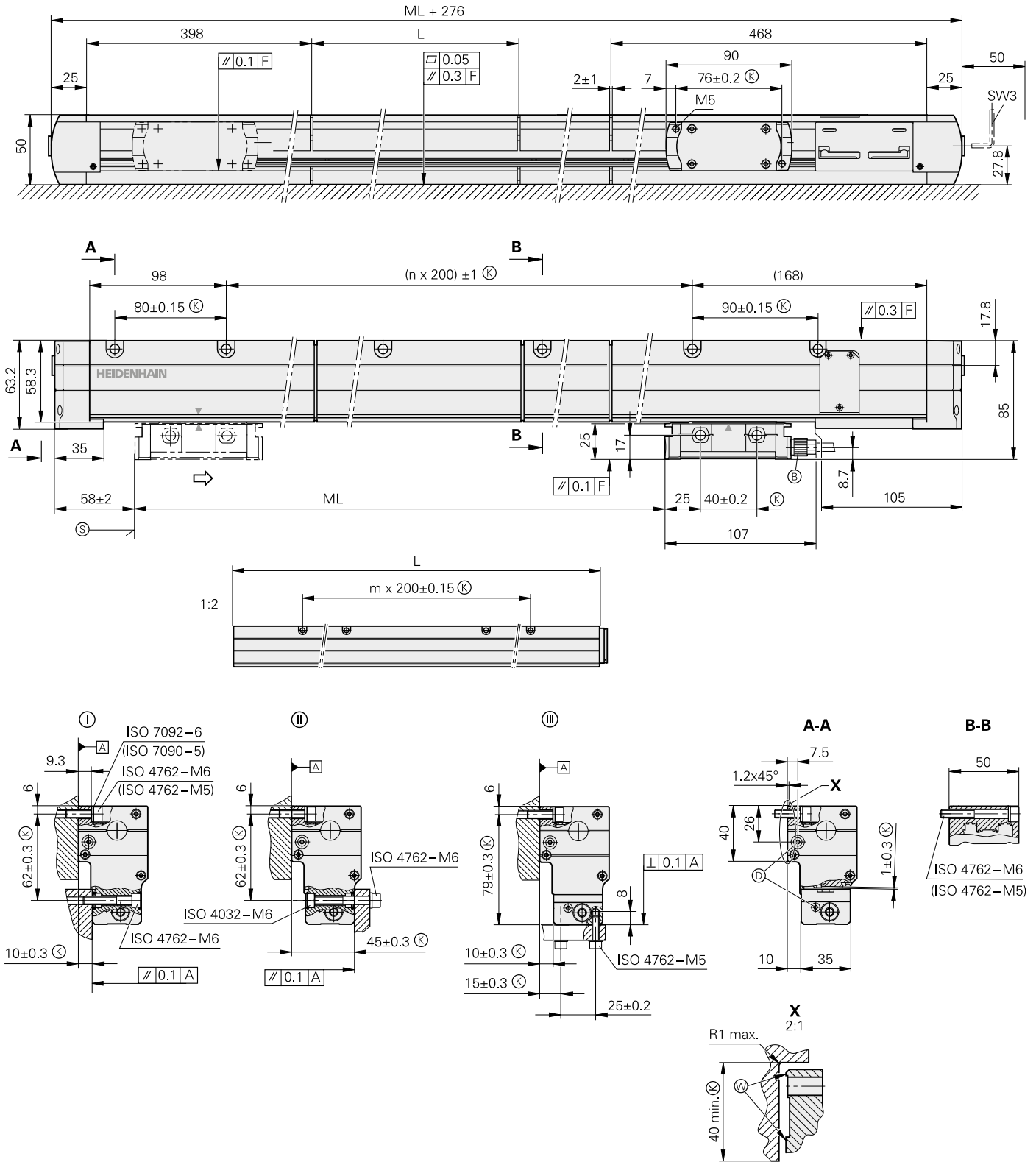

mm

 Tolerancing ISO 8015
 ISO 2768 - m H
 < 6 mm: ±0.2 mm

- Ⓞ, Ⓟ, Ⓢ = Mounting options
- F = Machine guideway
- L = Housing section lengths
- Ⓚ = Required mating dimensions
- Ⓛ = Cable connection usable at either end
- Ⓜ = Compressed-air connection usable at either end
- Ⓝ = Beginning of measuring length ML (= 100 mm absolute)
- Ⓞ = Mating surfaces
- ⇒ = Direction of scanning unit motion for output signals in accordance with interface description



Specifications	LC 211	LC 281	LC 291 F	LC 291 M
Measuring standard Coefficient of linear expansion	METALLUR steel scale tape with absolute track and incremental track, grating period 40 µm Same as machine base (e.g. $\alpha_{\text{therm}} \approx 10 \times 10^{-6} \text{ K}^{-1}$ for gray cast iron)			
Accuracy grade	± 5 µm			
Measuring length ML* in mm	3240 mm to 28040 mm in 200 mm steps Kit with single-section METALLUR steel scale tape and housing section lengths			
Interface	EnDat 2.2		Fanuc Serial Interface αi interface	Mitsubishi high speed interface
Ordering designation	EnDat22	EnDat02	Fanuc05	Mit03-04
Resolution	0.010 µm		αi interface/α interface 0.0125 µm/0.050 µm	0.010 µm
Diagnostics interface	Digital			
Clock frequency Calculation time t_{cal}	≤ 16 MHz ≤ 5 µs	≤ 2 MHz ≤ 5 µs	– –	
Incremental signals	–	~ 1 V _{PP}	–	
Signal period	–	40 µm	–	
Cutoff frequency –3 dB	–	≥ 250 kHz	–	
Electrical connection	Separate adapter cable (1 m/3 m/6 m/9 m) connectable on both sides to mounting block			
Cable length ¹⁾	≤ 100 m (at clock frequency ≤ 8 MHz)	≤ 150 m	≤ 50 m	≤ 30 m
Voltage supply	3.6 V to 14 V DC			
Power consumption (max.)	At 14 V: ≤ 1.3 W At 3.6 V: ≤ 1.1 W			
Current consumption (typical)	At 5 V: 225 mA (without load)			
Traversing speed	≤ 180 m/min			
Required moving force	≤ 15 N			
Vibration 55 to 2000 Hz affecting the Shock 11 ms Acceleration	Housing: 200 m/s ² (EN 60068-2-6) Scanning unit: 300 m/s ² (EN 60068-2-6) ≤ 300 m/s ² (EN 60068-2-27) ≤ 100 m/s ² in measuring direction			
Operating temperature	0 °C to +50 °C			
Protection EN 60529	IP 53 when installed according to mounting instructions, IP 64 with sealing air from DA 400			
Weight	1.3 kg + 3.6 kg/m measuring length			

* Please indicate when ordering

¹⁾ With HEIDENHAIN cable

LF 485

Incremental linear encoders with slimline scale housing

- Very high repeatability
- Thermal behavior similar to steel or gray cast iron
- For limited installation space

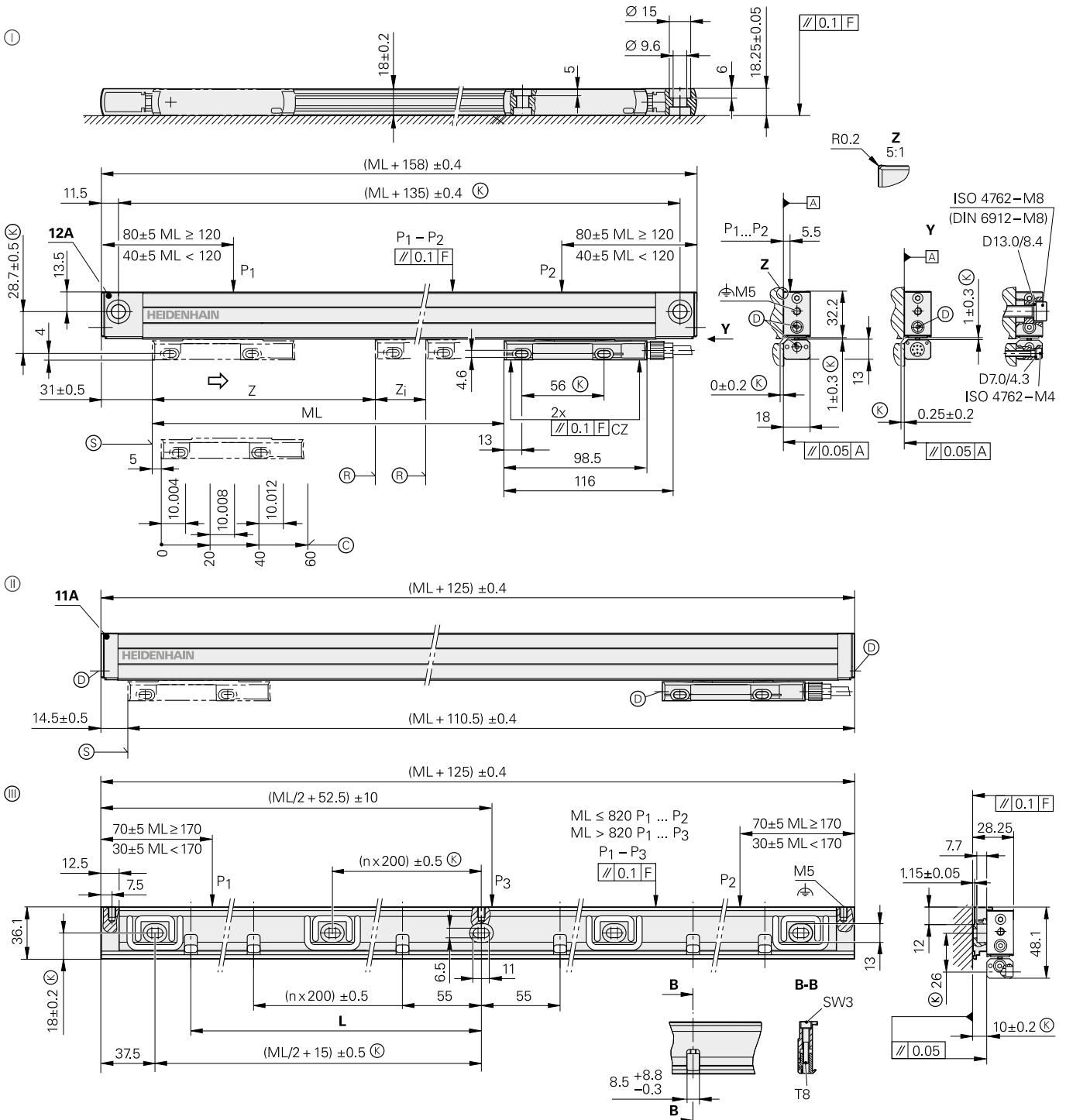

ML	50	100	150	200	250	300	350	400	450	500	550	600	650	700	750	800	850	900	950	1000	1050	1120	1220	1320	1420	1520	1620	1720	1820	2020
L	37.5	55	75	100	115	140	175	200	225	250	275	300	325	350	375	400	425	450	475	500	515	555	610	655	710	760	810	855	910	1010

mm
 Tolerancing ISO 8015
 ISO 2768 - m H
 < 6 mm: ±0.2 mm

- ⊙ = End block 12A; for mounting with and without mounting spar
- ⊙ = End block 11A; installation with mounting spar
- ⊙ = Mounting spar MSL 41
- F = Machine guideway
- P = Gauging points for alignment
- ⊙ = Required mating dimensions

- ⊙ = Reference mark position on LF 485
 2 reference marks for measuring lengths
 50 ... 1000 | 1120 ... 1220
 z = 25 mm | z = 35 mm
 z_i = ML - 50 mm | z_i = ML - 70 mm
- ⊙ = Reference-mark position on LF 485C
- ⊙ = Compressed air inlet
- ⊙ = Beginning of measuring length (ML)
- ⇒ = Direction of scanning unit motion for output signals in accordance with interface description



Specifications	LF 485
Measuring standard Coefficient of linear expansion	SUPRADUR phase grating on steel, grating period 8 μm $\alpha_{\text{therm}} \approx 10 \times 10^{-6} \text{K}^{-1}$
Accuracy grade*	$\pm 3 \mu\text{m}$; $\pm 5 \mu\text{m}$
Measuring length ML* in mm	Mounting spar* optional 50 100 150 200 250 300 350 400 450 500 550 600 650 700 750 800 900 1000 1120 1220
Interface	$\sim 1 \text{V}_{\text{PP}}$
Signal period	4 μm
Reference marks* LF 485 LF 485C	<ul style="list-style-type: none"> • 1 reference mark at midpoint of measuring length • 2 reference marks, each 25 mm (for ML \leq 1000 mm) or 35 mm (for ML \geq 1120 mm) from the beginning and end of the measuring length Distance-coded
Diagnostics interface	Analog
Cutoff frequency -3 dB	$\geq 250 \text{ kHz}$
Electrical connection	Separate adapter cable (1 m/3 m/6 m/9 m) connectible to mounting block
Cable length	$\leq 150 \text{ m}$ (with HEIDENHAIN cable)
Voltage supply without load	5 V DC $\pm 0.25 \text{ V}$ / $< 120 \text{ mA}$
Traversing speed	$\leq 60 \text{ m/min}$
Required moving force	$\leq 4 \text{ N}$
Vibration 55 to 2000 Hz affecting the Shock 11 ms Acceleration	<i>Housing with mounting spar:</i> $\leq 150 \text{ m/s}^2$ (EN 60068-2-6) <i>Scanning unit:</i> $\leq 200 \text{ m/s}^2$ (EN 60068-2-6) $\leq 300 \text{ m/s}^2$ (EN 60068-2-27) $\leq 100 \text{ m/s}^2$ in measuring direction
Operating temperature	0 $^{\circ}\text{C}$ to +50 $^{\circ}\text{C}$
Protection EN 60529	IP 53 when installed according to instructions in the brochure IP 64 with sealing air via DA 400
Weight	0.4 kg + 0.6 kg/m measuring length

* Please select when ordering

LF 185

Incremental linear encoders with full-size scale housing

- Very high repeatability
- Thermal behavior similar to steel or gray cast iron
- Reclining mounting possible

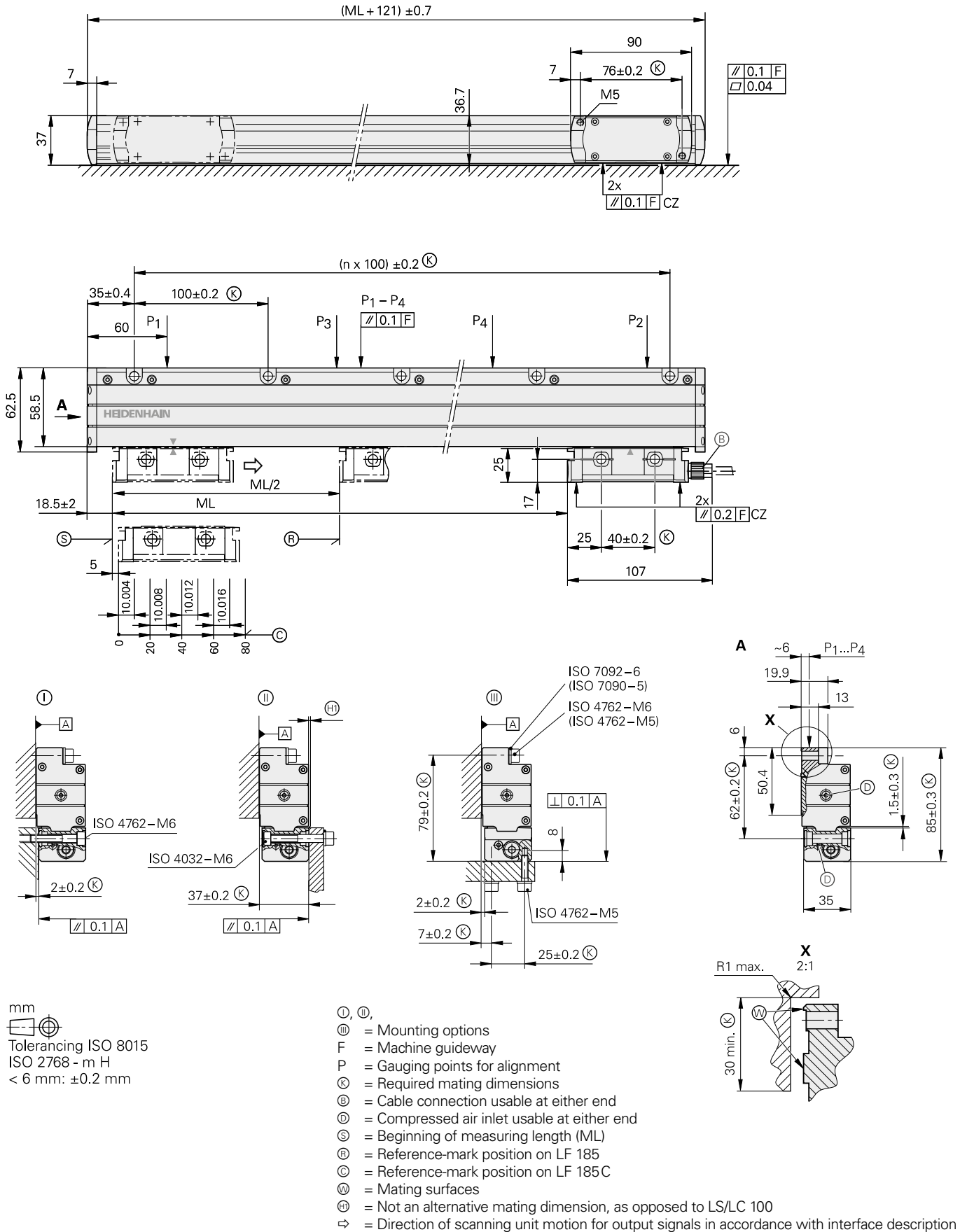



Specifications	LF 185
Measuring standard Coefficient of linear expansion	SUPRADUR phase grating on steel, grating period 8 µm $\alpha_{\text{therm}} \approx 10 \times 10^{-6} \text{ K}^{-1}$
Accuracy grade*	± 2 µm; ± 3 µm
Measuring length ML* in mm	140 240 340 440 540 640 740 840 940 1040 1140 1240 1340 1440 1540 1640 1740 1840 2040 2240 2440 2640 2840 3040
Interface	~ 1 V _{pp}
Signal period	4 µm
Reference marks* LF 185 LF 185C	1 reference mark at midpoint; other reference mark positions upon request Distance-coded
Diagnostics interface	Analog
Cutoff frequency -3 dB	≥ 250 kHz
Electrical connection	Separate adapter cable (1 m/3 m/6 m/9 m) connectible to mounting block
Cable length	≤ 150 m (with HEIDENHAIN cable)
Voltage supply without load	5 V DC ± 0.25 V/< 120 mA
Traversing speed	≤ 60 m/min
Required moving force	≤ 4 N
Vibration 55 to 2000 Hz affecting the Shock 11 ms Acceleration	Housing: ≤ 150 m/s ² (EN 60068-2-6) Scanning unit: ≤ 200 m/s ² (EN 60068-2-6) ≤ 300 m/s ² (EN 60068-2-27) ≤ 100 m/s ² in measuring direction
Operating temperature	0 °C to +50 °C
Protection EN 60529	IP 53 when installed according to instructions in the brochure IP 64 with sealing air via DA 400
Weight	0.8 kg + 4.6 kg/m measuring length

* Please select when ordering

LS 400 series

Incremental linear encoders with slimline scale housing
 • For limited installation space

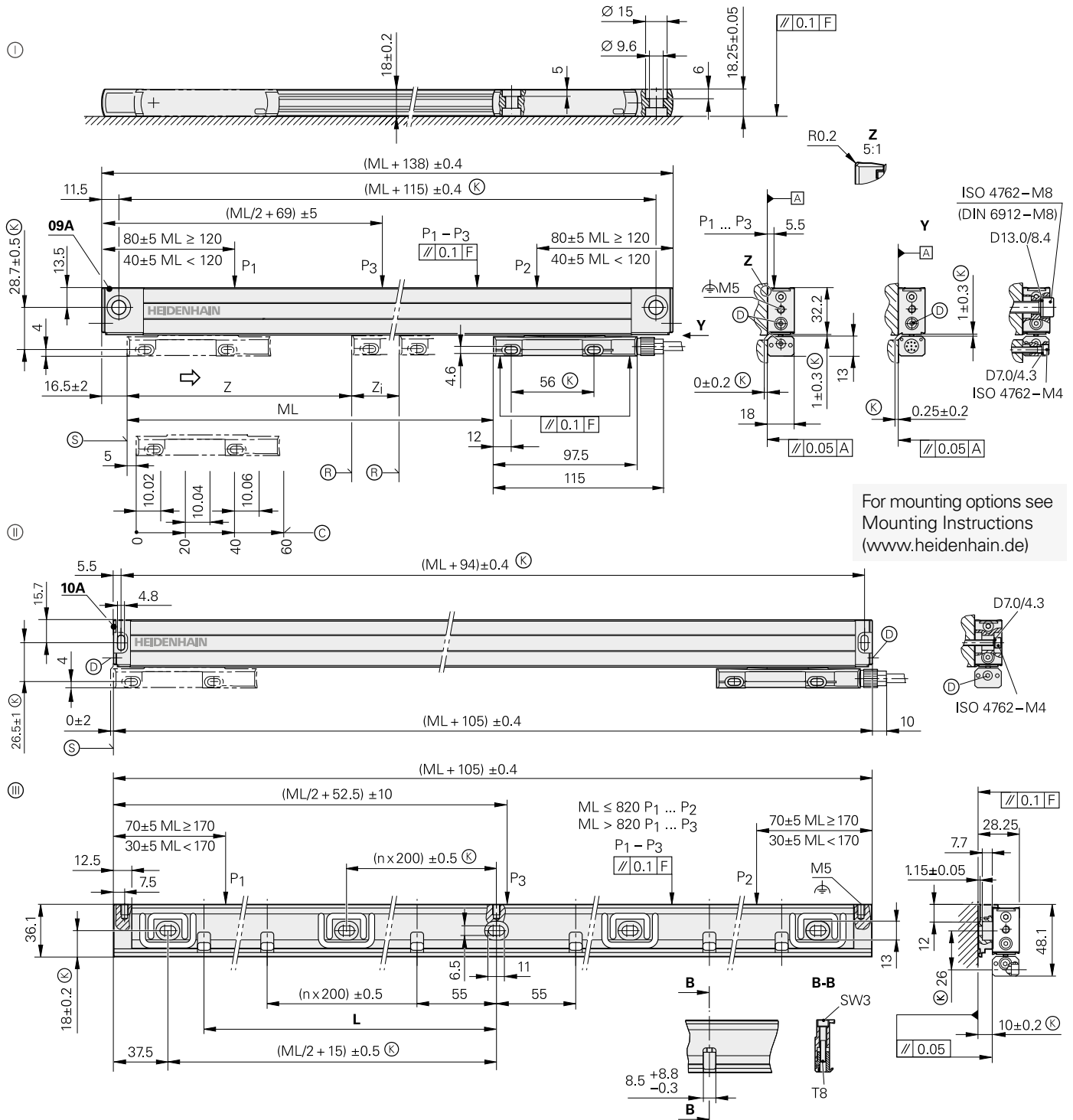

ML	70	120	170	220	270	320	370	420	470	520	570	620	670	720	770	820	870	920	970	1020	1070	1140	1240	1340	1440	1540	1640	1740	1840	2040
L	37.5	55	75	100	115	140	175	200	225	250	275	300	325	350	375	400	425	450	475	500	515	555	610	655	710	760	810	855	910	1010

mm
 Tolerancing ISO 8015
 ISO 2768 - m H
 < 6 mm: ±0.2 mm

- ⊖ = End block 09A; for mounting with and without mounting spar
- ⊙ = End block 10A; installation with mounting spar
- ⊕ = Mounting spar MSL 41
- F = Machine guideway
- P = Gauging points for alignment
- ⊗ = Required mating dimensions

- ⊙ = Reference mark position on LS 4x7
 2 reference marks for measuring lengths

70 ... 1020	1140 ... 2040
z = 35 mm	z = 45 mm
z _i = ML - 70 mm	z _i = ML - 90 mm
- ⊙ = Reference-mark position on LS 4x7C
- ⊙ = Compressed air inlet
- ⊙ = Beginning of measuring length (ML)
- ⇒ = Direction of scanning unit motion for output signals in accordance with interface description



LS 4x7 without mounting spar

LS 4x7 with mounting spar

Specifications	LS 487	LS 477														
Measuring standard Coefficient of linear expansion	Glass scale with DIADUR grating, grating period 20 µm $\alpha_{\text{therm}} \approx 8 \times 10^{-6} \text{ K}^{-1}$ (mounting type ○/⊙); <i>with mounting spar</i> : $\alpha_{\text{therm}} \approx 9 \times 10^{-6} \text{ K}^{-1}$ (mounting type ⊙)															
Accuracy grade*	± 3 µm; ± 5 µm															
Measuring length ML* in mm	Mounting spar* up to ML 1240 optional, necessary as of ML 1340 70 120 170 220 270 320 370 420 470 520 570 620 670 720 770 820 920 1020 1140 1240 1340 1440 1540 1640 1740 1840 2040															
Reference marks* LS 4x7 LS 4x7C	<ul style="list-style-type: none"> Selectable with magnets every 50 mm 1 reference mark at midpoint of measuring length 2 reference marks, each 35 mm (for ML ≤ 1020 mm) or 45 mm (for ML ≥ 1140 mm) from the beginning and end of the measuring length Distance-coded															
Interface	~ 1 V _{PP}		□TTL													
Integrated interpolation* Signal period	– 20 µm		5-fold 4 µm		10-fold 2 µm		20-fold 1 µm									
Diagnostics interface	Analog		–													
Cutoff frequency –3 dB	≥ 160 kHz		–		–		–									
Scanning frequency* Edge separation a	–		100 kHz ≥ 0.5 µs		50 kHz ≥ 1 µs		100 kHz ≥ 0.25 µs		50 kHz ≥ 0.5 µs		25 kHz ≥ 1 µs		50 kHz ≥ 0.25 µs		25 kHz ≥ 0.5 µs	
Measuring step	Depends on interpolation		1 µm ¹⁾		0.5 µm ¹⁾		0.25 µm ¹⁾									
Electrical connection	Separate adapter cable (1 m/3 m/6 m/9 m) connectible to mounting block															
Cable length ²⁾	≤ 150 m		≤ 100 m													
Voltage supply without load	5 V DC ± 0.25 V/< 120 mA		5 V DC ± 0.25 V/< 140 mA													
Traversing speed	≤ 120 m/min		≤ 120 m/min		≤ 60 m/min		≤ 120 m/min		≤ 60 m/min		≤ 30 m/min		≤ 60 m/min		≤ 30 m/min	
Required moving force	≤ 5 N															
Vibration 55 to 2000 Hz	<i>Without mounting spar</i> : ≤ 100 m/s ² (EN 60068-2-6) <i>With mounting spar, and cable outlet at right</i> : ≤ 200 m/s ² , <i>at left</i> : 100 m/s ² (EN 60068-2-6)															
Shock 11 ms Acceleration	≤ 300 m/s ² (EN 60068-2-27) ≤ 100 m/s ² in measuring direction															
Operating temperature	0 °C to +50 °C															
Protection EN 60529	IP 53 when installed according to mounting instructions and information; IP 64 with compressed air from DA 400															
Weight	0.4 kg + 0.5 kg/m measuring length															

* Please select when ordering

¹⁾ After 4-fold evaluation in the subsequent electronics

²⁾ With HEIDENHAIN cable

mm

<



Specifications	LS 187	LS 177																
Measuring standard Coefficient of linear expansion	Glass scale with DIADUR grating, grating period 20 µm $\alpha_{\text{therm}} \approx 8 \times 10^{-6} \text{ K}^{-1}$																	
Accuracy grade*	± 3 µm; ± 5 µm																	
Measuring length ML* in mm	140	240	340	440	540	640	740	840	940	1040	1140	1240	1340	1440				
Reference marks* <i>LS 1x7</i> <i>LS 1x7C</i>	Selectable with magnets every 50 mm, standard setting: 1 reference mark in the center Distance-coded																	
Interface	~ 1 V _{pp}				□TTL													
Integrated interpolation* Signal period	– 20 µm				5-fold 4 µm			10-fold 2 µm			20-fold 1 µm							
Diagnostics interface	Analog				–													
Cutoff frequency –3 dB	≥ 160 kHz				–			–			–							
Scanning frequency* Edge separation a	–				100 kHz ≥ 0.5 µs		50 kHz ≥ 1 µs		100 kHz ≥ 0.25 µs		50 kHz ≥ 0.5 µs		25 kHz ≥ 1 µs		50 kHz ≥ 0.25 µs		25 kHz ≥ 0.5 µs	
Measuring step	Depends on interpolation				1 µm ¹⁾			0.5 µm ¹⁾			0.25 µm ¹⁾							
Electrical connection	Separate adapter cable (1 m/3 m/6 m/9 m) connectible to mounting block																	
Cable length ²⁾	≤ 150 m				≤ 100 m													
Voltage supply without load	5V DC ± 0.25V/< 120 mA				5V DC ± 0.25V/< 140 mA													
Traversing speed	≤ 120 m/min				≤ 120 m/min		≤ 60 m/min		≤ 120 m/min		≤ 60 m/min		≤ 30 m/min		≤ 60 m/min		≤ 30 m/min	
Required moving force	≤ 4 N																	
Vibration 55 to 2000 Hz Shock 11 ms Acceleration	≤ 200 m/s ² (EN 60068-2-6) ≤ 400 m/s ² (EN 60068-2-27) ≤ 60 m/s ² in measuring direction																	
Operating temperature	0 °C to +50 °C																	
Protection EN 60529	IP 53 when mounted according to the instructions and mounting information IP 64 if compressed air is connected via DA 400																	
Weight	0.4 kg + 2.3 kg/m measuring length																	

* Please select when ordering

¹⁾ After 4-fold evaluation in the subsequent electronics

²⁾ With HEIDENHAIN cable

LB 382 up to 3040 mm measuring length (single-section housing)

Incremental linear encoders with full-size scale housing

- Reclining mounting possible
- Also available in mirrored version (mating dimensions upon request)

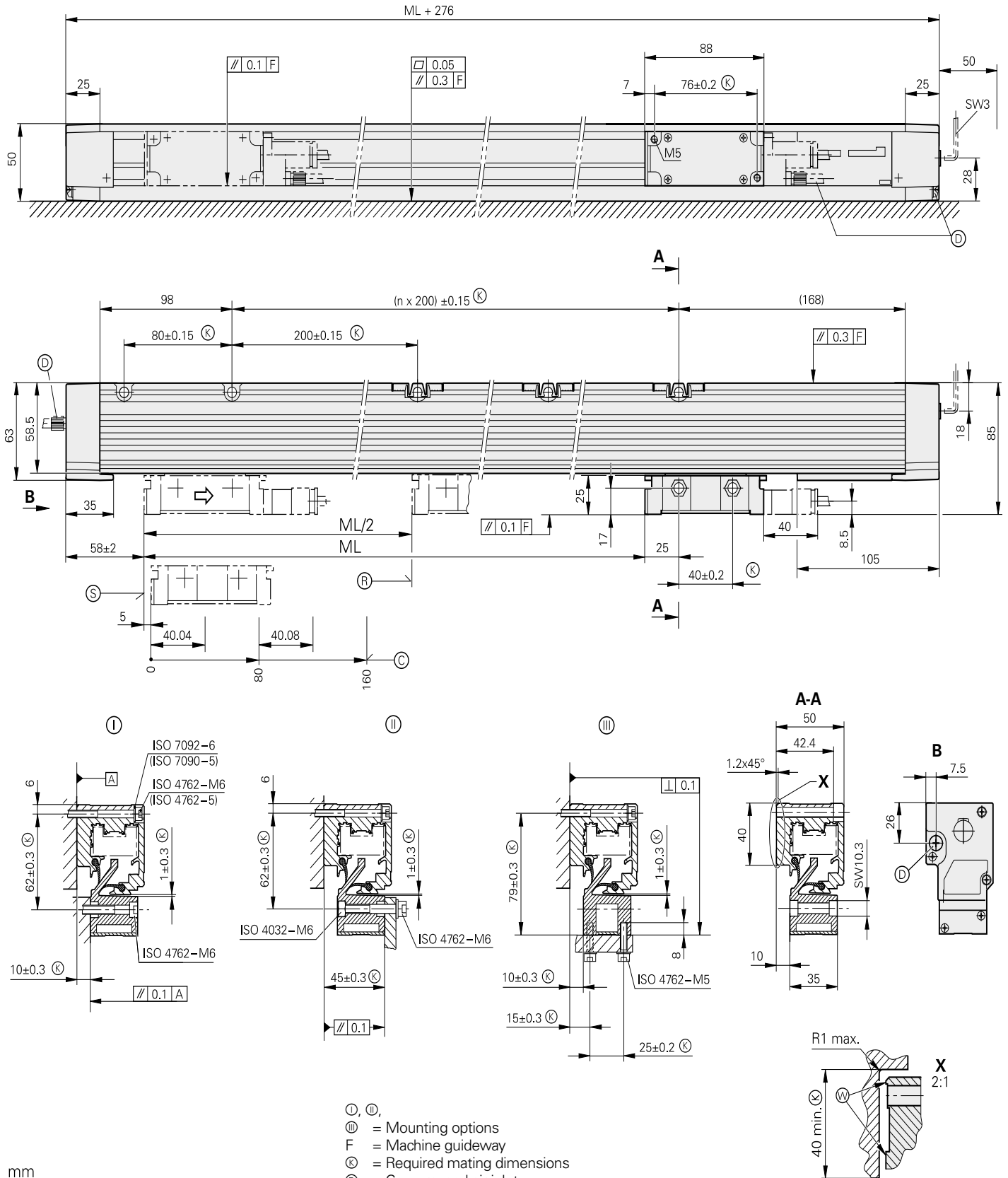

mm

 Tolerancing ISO 8015
 ISO 2768 - m H
 < 6 mm: ± 0.2 mm

- ⓪, ⓐ, ⓑ
- ⓓ = Mounting options
- F = Machine guideway
- Ⓚ = Required mating dimensions
- Ⓛ = Compressed air inlet
- Ⓡ = Reference-mark position on LB 3x2
- Ⓢ = Reference-mark position on LB 3x2C
- Ⓣ = Beginning of measuring length (ML)
- Ⓜ = Mating surfaces
- ⇒ = Direction of scanning unit motion for output signals in accordance with interface description



Specifications	LB 382 up to ML 3040 mm
Measuring standard Coefficient of linear expansion	Rustproof steel scale tape with AURODUR graduation, grating period 40 µm $\alpha_{\text{therm}} \approx 10 \times 10^{-6} \text{ K}^{-1}$
Accuracy grade	± 5 µm
Measuring length ML* in mm	Single-section housing 440 640 840 1040 1240 1440 1640 1840 2040 2240 2440 2640 2840 3040
Reference marks* <i>LB 382</i> <i>LB 382 C</i>	Selectable by selector plate every 50 mm, standard setting: 1 reference mark in the center Distance-coded
Interface	~ 1 V _{PP}
Signal period	40 µm
Diagnostics interface	Analog
Cutoff frequency -3 dB	≥ 250 kHz
Electrical connection	Separate adapter cable (1 m/3 m/6 m/9 m) connectible to mounting block
Cable length ¹⁾	≤ 150 m
Voltage supply without load	5 V DC ± 25 V / < 150 mA
Traversing speed	≤ 120 m/min
Required moving force	≤ 15 N
Vibration 55 to 2000 Hz Shock 11 ms Acceleration	≤ 300 m/s ² (EN 60068-2-6) ≤ 300 m/s ² (EN 60068-2-27) ≤ 60 m/s ² in measuring direction
Operating temperature	0 °C to +50 °C
Protection EN 60529	IP 53 when mounted according to the instructions and mounting information IP 64 if compressed air is connected via DA 400
Weight	1.3 kg + 3.6 kg/m measuring length

* Please indicate when ordering

¹⁾ With HEIDENHAIN cable

LB 382 up to 30040 mm measuring length (multi-section housing)

Incremental linear encoders with full-size scale housing

- Measuring lengths up to 30 m (to 72 m upon request)
- Reclining mounting possible
- Also available in mirrored version (mating dimensions upon request)

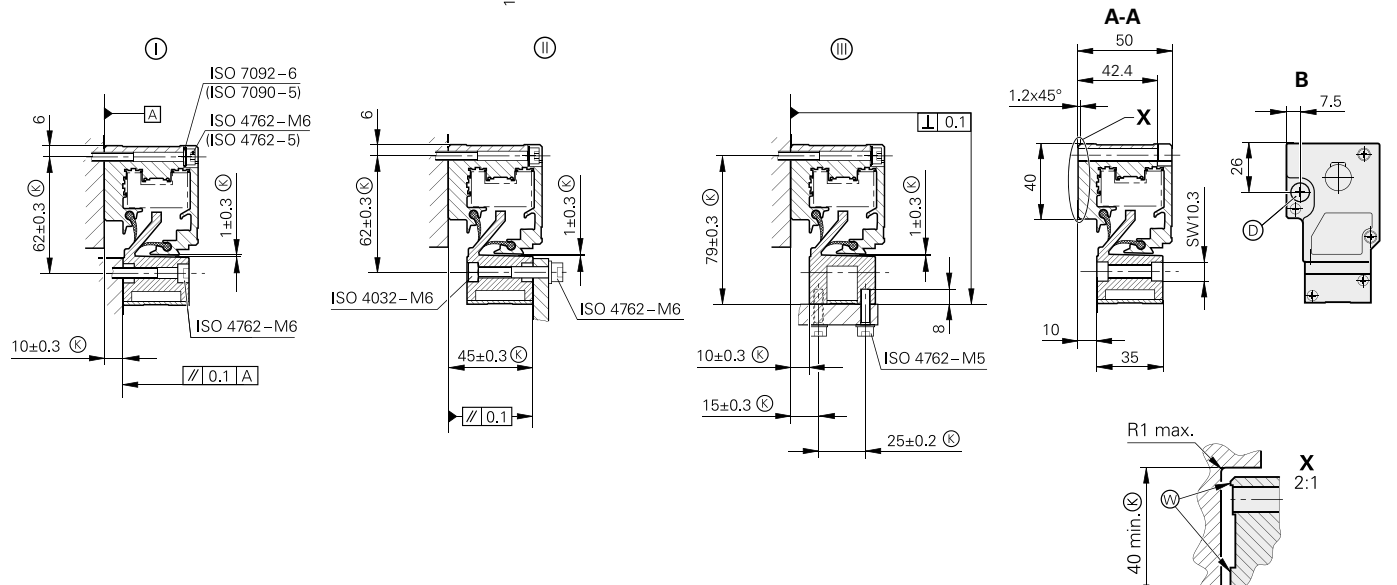
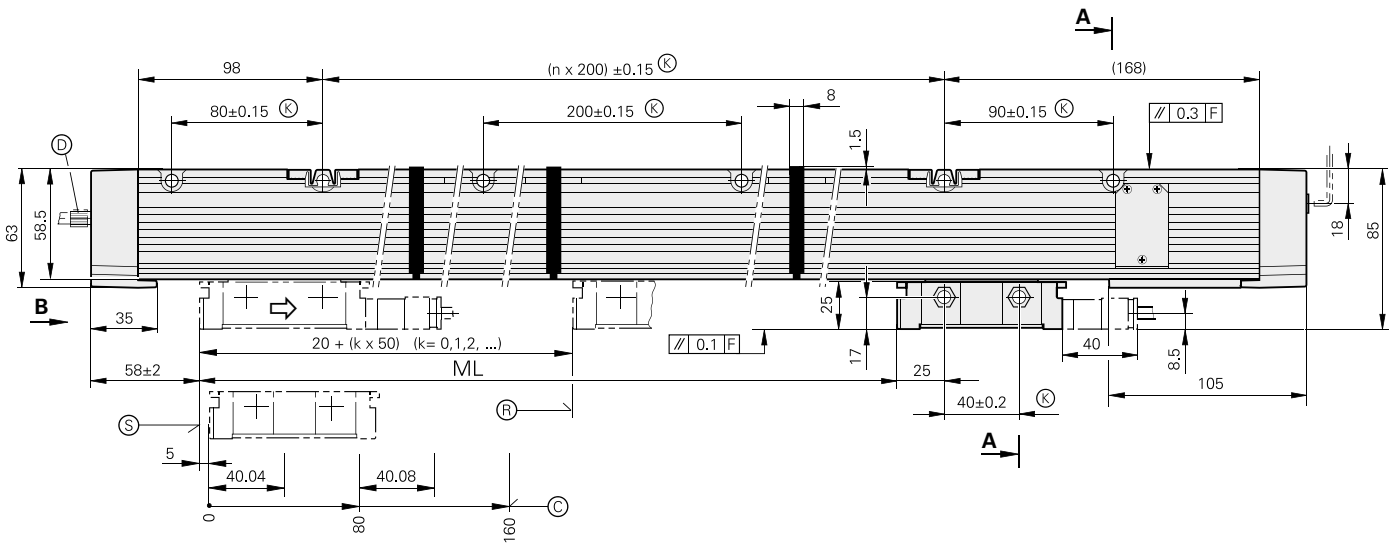
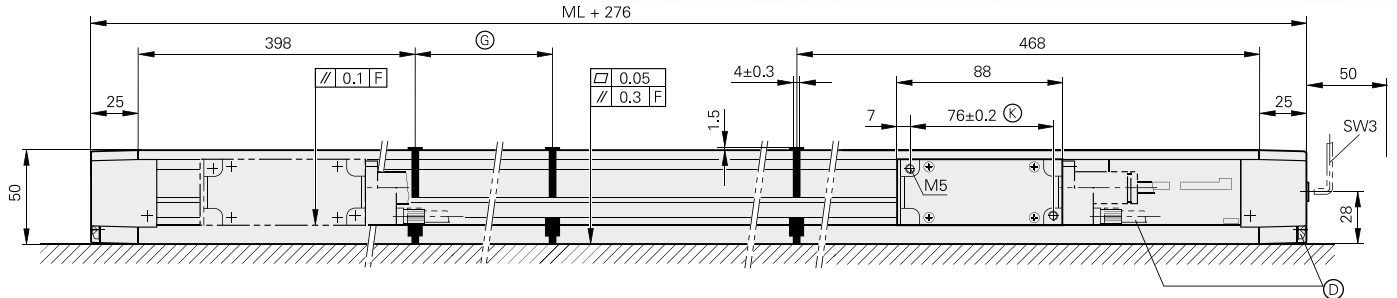

mm
 Tolerancing ISO 8015
 ISO 2768 - m H
 < 6 mm: ±0.2 mm

- Ⓘ, Ⓜ, = Mounting options
- F = Machine guideway
- Ⓢ = Required mating dimensions
- Ⓣ = Compressed air inlet
- Ⓤ = Reference-mark position on LB 3x2
- Ⓦ = Reference-mark position on LB 3x2C
- Ⓨ = Beginning of measuring length (ML)
- Ⓩ = Housing section lengths
- Ⓩ = Mating surfaces
- ⇒ = Direction of scanning unit motion for output signals in accordance with interface description



Specifications	LB 382 from ML 3240 mm
Measuring standard Coefficient of linear expansion	Rustproof steel scale tape with AURODUR graduation, grating period 40 µm Same as machine main casting
Accuracy grade	± 5 µm
Measuring length ML*	Kit with single-section AURODUR steel tape and housing sections for measuring lengths from 3240 mm to 30040 mm in 200 mm steps (up to 72040 mm upon request) Housing section lengths: 1000 mm, 1200 mm, 1400 mm, 1600 mm, 1800 mm, 2000 mm
Reference marks* <i>LB 382</i> <i>LB 382 C</i>	Selectable by selector plate every 50 mm Distance-coded
Interface	~ 1 V _{PP}
Signal period	40 µm
Diagnostics interface	Analog
Cutoff frequency -3 dB	≥ 250 kHz
Electrical connection	Separate adapter cable (1 m/3 m/6 m/9 m) connectible to mounting block
Cable length ¹⁾	≤ 150 m
Voltage supply without load	5 V DC ± 0.25 V/< 150 mA
Traversing speed	≤ 120 m/min
Required moving force	≤ 15 N
Vibration 55 to 2000 Hz Shock 11 ms Acceleration	≤ 300 m/s ² (EN 60068-2-6) ≤ 300 m/s ² (EN 60068-2-27) ≤ 60 m/s ² in measuring direction
Operating temperature	0 °C to +50 °C
Protection EN 60529	IP 53 when mounted according to the instructions and mounting information IP 64 if compressed air is connected via DA 400
Weight	1.3 kg + 3.6 kg/m measuring length

* Please indicate when ordering

¹⁾ With HEIDENHAIN cable

Interfaces

Incremental signals $\sim 1 V_{PP}$

HEIDENHAIN encoders with $\sim 1 V_{PP}$ interface provide voltage signals that can be highly interpolated.

The sinusoidal **incremental signals** A and B are phase-shifted by 90° elec. and have amplitudes of typically $1 V_{PP}$. The illustrated sequence of output signals—with B lagging A—applies for the direction of motion shown in the dimension drawing.

The **reference mark signal** R has an unambiguous assignment to the incremental signals. The output signal might be somewhat lower next to the reference mark.

Comprehensive descriptions of all available interfaces as well as general electrical information are included in the *Interfaces for HEIDENHAIN Encoders* catalog.

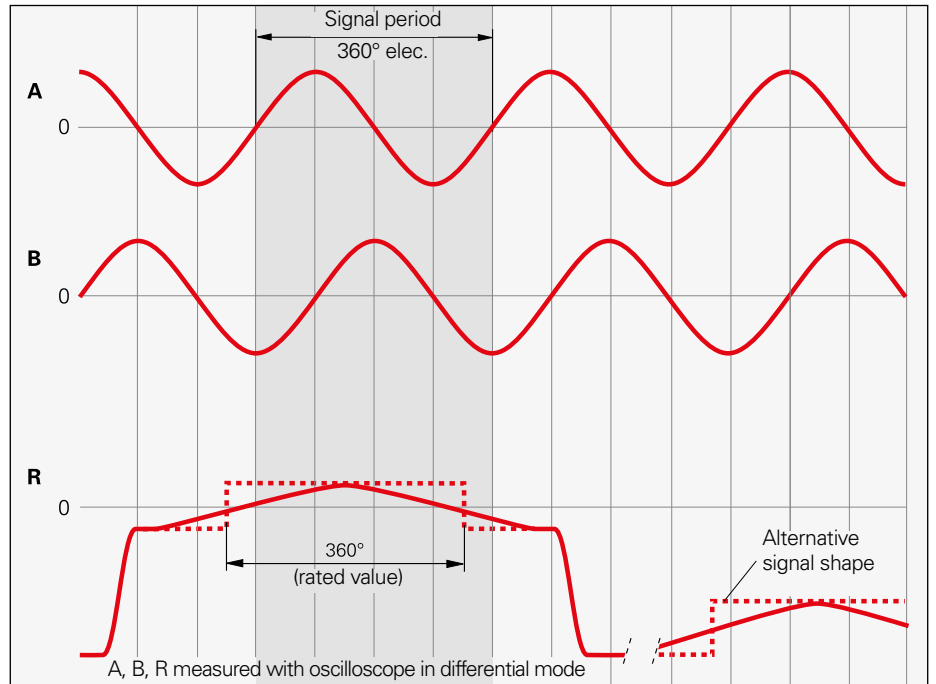

Pin layout

12-pin coupling, M23					12-pin connector, M23									
15-pin D-sub connector					15-pin D-sub connector									
For HEIDENHAIN controls and IK 220					For encoders or IK 215									
	Voltage supply				Incremental signals						Other signals			
	12	2	10	11	5	6	8	1	3	4	9	7	/	
	1	9	2	11	3	4	6	7	10	12	5/8/13/15	14	/	
	4	12	2	10	1	9	3	11	14	7	5/6/8/15	13	/	
	U_P	Sensor ¹⁾ U_P	0V	Sensor ¹⁾ 0V	A+	A-	B+	B-	R+	R-	Vacant	Vacant	Vacant	
	Brown/ Green	Blue	White/ Green	White	Brown	Green	Gray	Pink	Red	Black	/	Violet	Yellow	

Cable shield connected to housing; U_P = power supply voltage

Sensor: The sensor line is connected in the encoder with the corresponding power line.

Vacant pins or wires must not be used!

¹⁾ LIDA 2xx: Vacant

Incremental signals TTL

HEIDENHAIN encoders with  TTL interface incorporate electronics that digitize sinusoidal scanning signals with or without interpolation.

The **incremental signals** are transmitted as the square-wave pulse trains U_{a1} and U_{a2} , phase-shifted by 90° elec. The **reference mark signal** consists of one or more reference pulses U_{a0} , which are gated with the incremental signals. In addition, the integrated electronics produce their **inverted signals** $\overline{U_{a1}}$, $\overline{U_{a2}}$ and $\overline{U_{a0}}$ for noise-proof transmission. The illustrated sequence of output signals—with U_{a2} lagging U_{a1} —applies to the direction of motion shown in the dimension drawing.





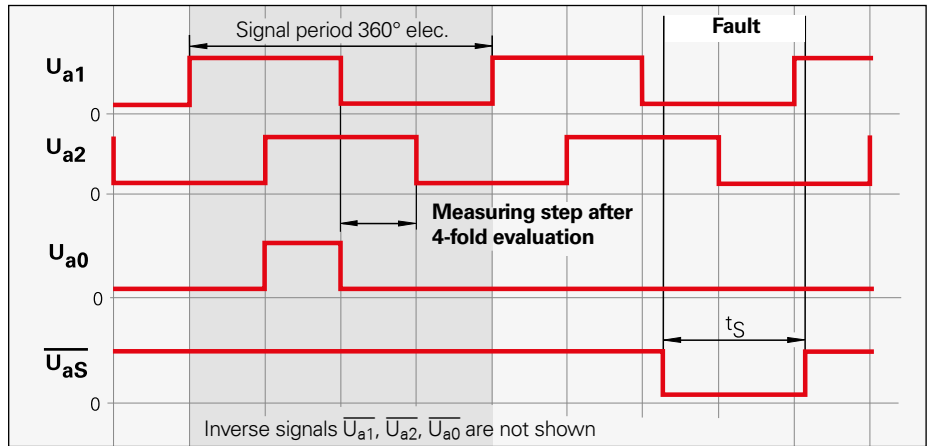



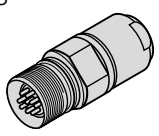
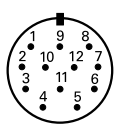

The **fault detection signal** $\overline{U_{aS}}$ indicates fault conditions such as an interruption in the supply lines, failure of the light source, etc.

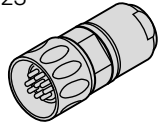
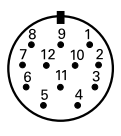
The distance between two successive edges of the incremental signals U_{a1} and U_{a2} through 1-fold, 2-fold or 4-fold evaluation is one **measuring step**.

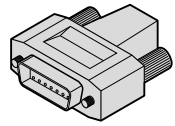
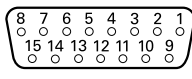

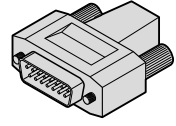
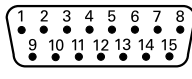
Comprehensive descriptions of all available interfaces as well as general electrical information are included in the *Interfaces for HEIDENHAIN Encoders* catalog.

Pin layout

12-pin coupling, M23				12-pin connector, M23									
													
15-pin D-sub connector For HEIDENHAIN controls and IK 220				15-pin D-sub connector For encoder or PWM 20									
													
	Voltage supply			Incremental signals						Other signals			
	12	2	10	11	5	6	8	1	3	4	7	/	9 ³⁾
	1	9	2	11	3	4	6	7	10	12	14	8/13/15	5
	4	12	2	10	1	9	3	11	14	7	13	5/6/8	15 ³⁾
	U_P	Sensor ¹⁾ U_P	0V	Sensor ¹⁾ 0V	U_{a1}	$\overline{U_{a1}}$	U_{a2}	$\overline{U_{a2}}$	U_{a0}	$\overline{U_{a0}}$	$\overline{U_{aS}}$ ²⁾	Vacant	Vacant
	Brown/ Green	Blue	White/ Green	White	Brown	Green	Gray	Pink	Red	Black	Violet	/	Yellow

Cable shield connected to housing; U_P = power supply voltage

Sensor: The sensor line is connected in the encoder with the corresponding power line.

Vacant pins or wires must not be used!

¹⁾ LIDA 2xx: Vacant / ²⁾ ERO 14xx: Vacant

³⁾ **Exposed linear encoders:** Switchover TTL/11 μA_{PP} for PWT, otherwise vacant

Interfaces

Position values

The EnDat interface is a digital, **bidirectional** interface for encoders. It is capable both of transmitting **position values** as well as transmitting or updating information stored in the encoder, or saving new information. Thanks to the **serial transmission method**, only **four signal lines** are required. The DATA data is transmitted in **synchronism** with the CLOCK signal from the subsequent electronics. The type of transmission (position values, parameters, diagnostics, etc.) is selected through mode commands that the subsequent electronics send to the encoder. Some functions are available only with EnDat 2.2 mode commands.

Comprehensive descriptions of all available interfaces as well as general electrical information are included in the *Interfaces for HEIDENHAIN Encoders* catalog.

Ordering designation	Command set	Incremental signals
EnDat01	EnDat 2.1 or EnDat 2.2	With
EnDat21		Without
EnDat02	EnDat 2.2	With
EnDat22	EnDat 2.2	Without

Versions of the EnDat interface

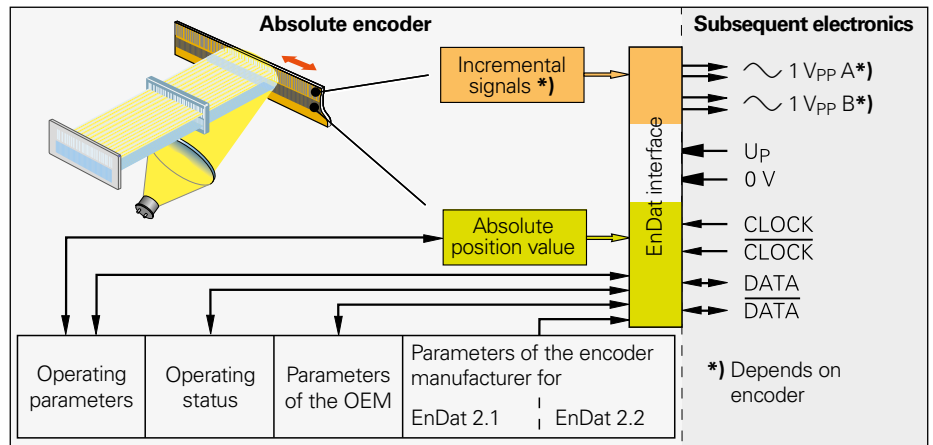

Pin layout

8-pin coupling, M12								
	Voltage supply				Absolute position values			
	8	2	5	1	3	4	7	6
	Up	Sensor Up	0V	Sensor 0V	DATA	DATA	CLOCK	CLOCK
	Brown/Green	Blue	White/Green	White	Gray	Pink	Violet	Yellow

17-pin coupling, M23						15-pin D-sub connector For HEIDENHAIN controls and IK 220							
	Voltage supply					Incremental signals ¹⁾				Absolute position values			
	7	1	10	4	11	15	16	12	13	14	17	8	9
	1	9	2	11	13	3	4	6	7	5	8	14	15
	Up	Sensor Up	0V	Sensor 0V	Internal shield	A+	A-	B+	B-	DATA	DATA	CLOCK	CLOCK
	Brown/Green	Blue	White/Green	White	/	Green/Black	Yellow/Black	Blue/Black	Red/Black	Gray	Pink	Violet	Yellow

Cable shield connected to housing; **Up** = power supply voltage

Sensor: The sensor line is connected in the encoder with the corresponding power line.

Vacant pins or wires must not be used!

¹⁾ Only with order designations EnDat01 and EnDat02

Fanuc and Mitsubishi pin layouts

Fanuc pin layout







HEIDENHAIN encoders with the code letter F after the model designation are suited for connection to Fanuc controls with

- **Fanuc Serial Interface – α Interface**

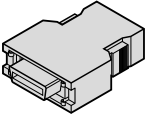
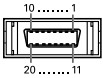
Ordering designation: Fanuc02
Normal and high speed, two-pair transmission

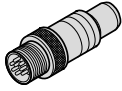
- **Fanuc Serial Interface – α i interface**

Ordering designation: Fanuc05
High speed, one-pair transmission
Includes α interface (normal and high speed, two-pair transmission)

20-pin Fanuc connector					8-pin coupling, M12				
									
	Voltage supply					Absolute position values			
	9	18/20	12	14	16	1	2	5	6
	8	2	5	1	–	3	4	7	6
	U_P	Sensor U _P	0V	Sensor 0V	Shield	Serial Data	Serial Data	Request	Request
	Brown/ Green	Blue	White/ Green	White	–	Gray	Pink	Violet	Yellow

Cable shield connected to housing; **U_P** = power supply voltage

Sensor: The sensor line is connected in the encoder with the corresponding power line.

Vacant pins or wires must not be used!









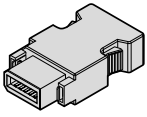
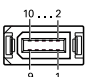

Mitsubishi pin layout

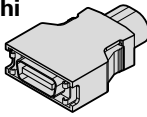
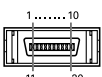
HEIDENHAIN encoders with the code letter M after the model designation are suited for connection to Mitsubishi controls with

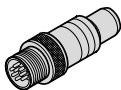
- **Mitsubishi high speed interface**

Ordering designation: Mitsu01
Two-pair transmission

- Ordering designation: Mit02-4
Generation 1, two-pair transmission
- Ordering designation: Mit02-2
Generation 1, one-pair transmission
- Ordering designation: Mit03-4
Generation 2, two-pair transmission

10-pin Mitsubishi connector			20-pin Mitsubishi connector			8-pin coupling, M12			
									
	Voltage supply					Absolute position values			
	10-pin	1	–	2	–	7	8	3	4
	20-pin	20	19	1	11	6	16	7	17
	8	2	5	1	3	4	7	6	
	U_P	Sensor U _P	0V	Sensor 0V	Serial Data	Serial Data	Request Frame	Request Frame	
	Brown/Green	Blue	White/Green	White	Gray	Pink	Violet	Yellow	

Cable shield connected to housing; **U_P** = power supply voltage

Sensor: The sensor line is connected in the encoder with the corresponding power line.

Vacant pins or wires must not be used!







Siemens pin layout

Siemens pin layout

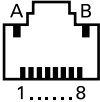
HEIDENHAIN encoders with the code letter S after the model designation are suited for connection to Siemens controls with **DRIVE-CLiQ interface**

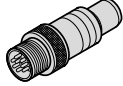
- Ordering designation DQ01

DRIVE-CLiQ is a registered trademark of SIEMENS Aktiengesellschaft

RJ45 connector			8-pin coupling, M12			
						
	Voltage supply		Absolute position values			
			Transmit data		Receive data	
	A	B	3	6	1	2
	1	5	7	6	3	4
	U_p	0V	TXP	TXN	RXP	RXN

Cable shield connected to housing; **U_p** = power supply voltage

Cables and connecting elements

General information

Connector (insulated): A connecting element with a coupling ring. Available with male or female contacts.

Symbols



M12

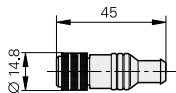

M23

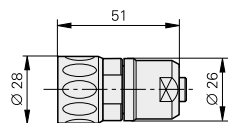

Flange socket: Permanently mounted on the encoder or a housing, with external thread (like a coupling), available with male or female contacts.

Symbols



M23

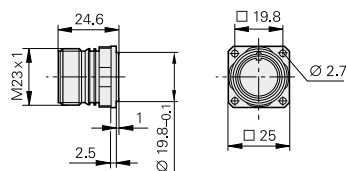

Coupling (insulated): Connecting element with external thread. Available with male or female contacts.

Symbols



On the adapter cable

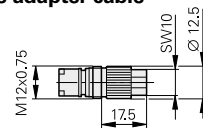

M12

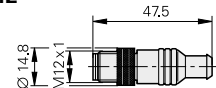

M23

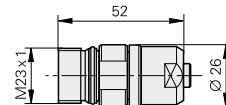

Mounted coupling with central fastening

Cutout for mounting **M23**

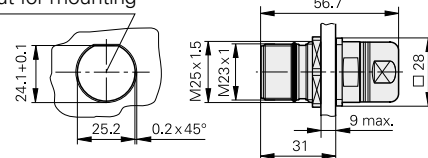

Mounted coupling with flange

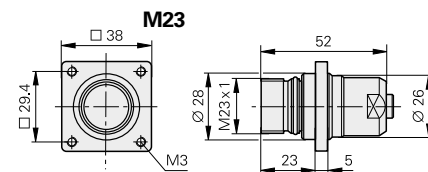

The pins on connectors are **numbered** in the direction opposite to those on couplings or flange sockets, regardless of whether the connecting elements have

male contacts or



female contacts.



When engaged, the connections are **protected** to IP 67 (D-sub connector: IP 50; RJ-45: IP 20; EN 60 529). When not engaged, there is no protection.

Accessories for flange sockets and M23 mounted couplings

Bell seal

ID 266526-01

Threaded metal dust cap

ID 219926-01

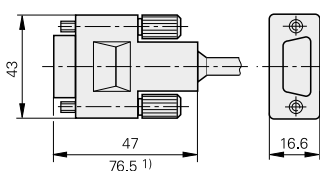

D-sub connector: For HEIDENHAIN controls, counters and IK absolute value cards.

Symbols

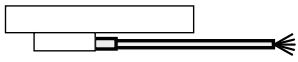
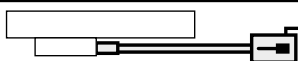

¹⁾ With integrated interpolation electronics

Adapter cables

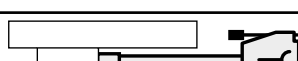
For incremental linear encoders		Cable Ø	LB 382	LF 185/485 LS 187/177 LS 487/477
PUR [6(2 x 0.19 mm ²); A _P = 0.19 mm ²]				
Adapter cable with M23 coupling (male), 12-pin		6 mm	310128-xx	360645-xx
Adapter cable without connector		6 mm	310131-xx	354319-xx
Adapter cable with M23 connector (male), 12-pin		6 mm 4.5 mm	310127-xx –	344228-xx 352611-xx ¹⁾
Adapter cable in metal armor with M23 connector (male), 12-pin		10 mm	310126-xx	344451-xx
Adapter cable with D-sub connector, 15-pin		6 mm	298429-xx	360974-xx

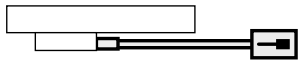
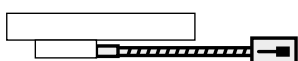
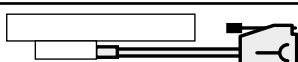

A_P = Cross section of power supply lines

¹⁾ PUR [4(2 x 0.05 mm²) + (4 x 0.14 mm²); A_P = 0.14 mm²]

For absolute linear encoders – EnDat with incremental signals		Cable Ø	LC 185 LC 485 LC 281
PUR [6(2 x 0.19 mm ²); A _P = 0.19 mm ²]			
Adapter cable with M23 coupling (male), 17-pin		6 mm	533631-xx
Adapter cable in metal armor with M23 coupling (male), 17-pin		10 mm	558362-xx
Adapter cable with D-sub connector, 15-pin		6 mm	558714-xx

Available cable lengths: 1 m/3 m/6 m/9 m

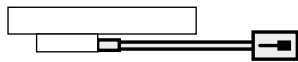
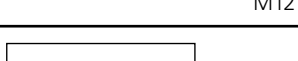



A_P = Cross section of power supply lines

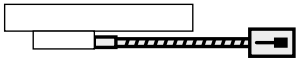
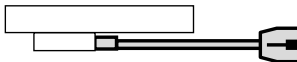

For absolute linear encoders – EnDat without incremental signals		Cable Ø	LC 115 LC 415 LC 211
PUR [4(2 x 0.14 mm ²); A _P = 0.14 mm ²]			
Adapter cable with M12 coupling (male), 8-pin	 M12	4.5 mm	533661-xx
Adapter cable in metal armor with M12 coupling (male), 8-pin	 M12	10 mm	550678-xx
Adapter cable with D-sub connector, 25-pin		6 mm	1083369-xx ¹⁾

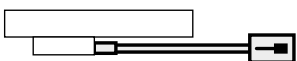
A_P = Cross section of power supply lines

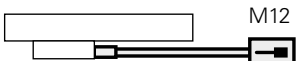
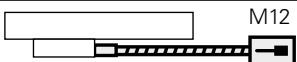
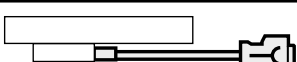
¹⁾ PUR [2(2 x 0.9 mm²) + (2 x 0.14 mm²); A_P = 0.14 mm²]

For absolute linear encoders – Siemens PUR [2(2 x 0.17 mm ²) + (2 x 0.24 mm ²)]; A _P = 0.24 mm ²		Cable Ø	LC 195 S LC 495 S
Adapter cable with M12 coupling (male), 8-pin		6.8 mm	805452-xx
Adapter cable in metal armor with M12 coupling (male), 8-pin		11.1 mm	816675-xx
Adapter cable with Siemens connector, RJ45 (IP 20)		6.8 mm	805375-xx

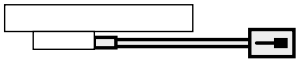
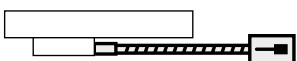
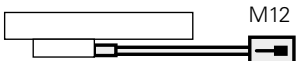
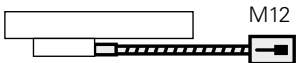
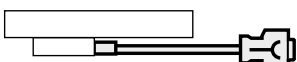
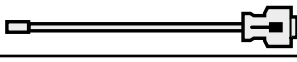
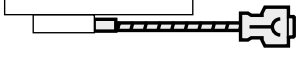
For absolute linear encoders – Fanuc PUR [4(2 x 0.14 mm ²)]; A _P = 0.14 mm ²		Cable Ø	LC 195 F LC 495 F LC 291 F
Adapter cable with M23 coupling (male), 17-pin		6 mm 4.5 mm	– 547300-xx
Adapter cable in metal armor with M23 coupling (male), 17-pin		10 mm	555541-xx
Adapter cable with M12 coupling (male), 8-pin		4.5 mm	533661-xx
Adapter cable in metal armor with M12 coupling (male), 8-pin		10 mm	550678-xx
Adapter cable with Fanuc connector, 20-pin		4.5 mm	545547-xx
Adapter cable in metal armor with Fanuc connector, 20-pin		10 mm	551027-xx







For absolute linear encoders – Mitsubishi PUR [4(2 x 0.14 mm ²)]; A _P = 0.14 mm ²		Cable Ø	LC 195 M LC 495 M LC 291 M
Adapter cable with M23 coupling (male), 17-pin		6 mm 4.5 mm	– 547300-xx
Adapter cable in metal armor with M23 coupling (male), 17-pin		10 mm	555541-xx
Adapter cable with M12 coupling (male), 8-pin		4.5 mm	533661-xx
Adapter cable in metal armor with M12 coupling (male), 8-pin		10 mm	550678-xx
Adapter cable with Mitsubishi connector, 10-pin		4.5 mm	640915-xx
Adapter cable with Mitsubishi connector, 20-pin		4.5 mm	599685-xx
Adapter cable in metal armor with Mitsubishi connector, 10-pin		10 mm	640916-xx
Adapter cable in metal armor with Mitsubishi connector, 20-pin		10 mm	599688-xx

Available cable lengths: 1 m/3 m/6 m/9 m
A_P = Cross section of power supply lines

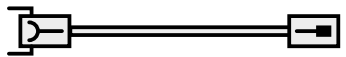
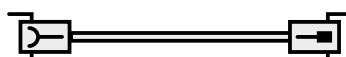
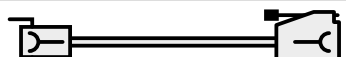
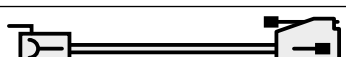
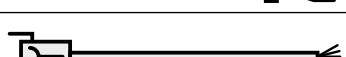
Connecting cables $\sim 1\text{ V}_{PP}$

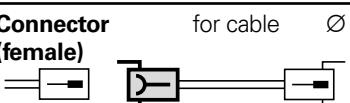
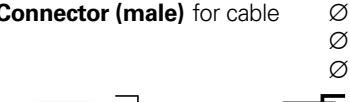
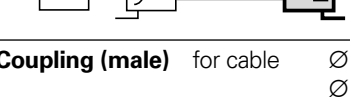

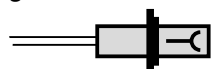
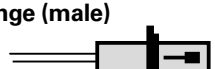
 TTL
EnDat

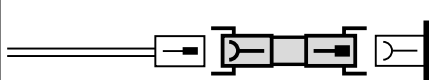

12-pin M23 17-pin M23 8-pin M12

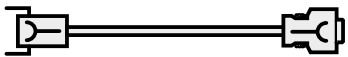
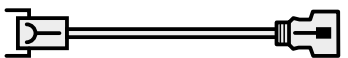
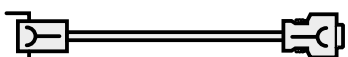

	$\sim 1\text{ V}_{PP}$  TTL	EnDat with SSI incremental signals	EnDat without incremental signals	
PUR connecting cables	8-pin: $[(4 \times 0.14\text{ mm}^2) + (4 \times 0.34\text{ mm}^2)]; A_P = 0.34\text{ mm}^2$ 12-pin: $[4(2 \times 0.14\text{ mm}^2) + (4 \times 0.5\text{ mm}^2)]; A_P = 0.5\text{ mm}^2$ 17-pin: $[(4 \times 0.14\text{ mm}^2) + 4(2 \times 0.14\text{ mm}^2) + (4 \times 0.5\text{ mm}^2)]; A_P = 0.5\text{ mm}^2$		Ø 6 mm Ø 8 mm Ø 8 mm	
Complete with connector (female) and coupling (male)		298401-xx	323897-xx	368330-xx
Complete with connectors (female and male)		298399-xx	–	–
Complete with connector (female) and D-sub connector (female) for IK 220		310199-xx	332115-xx	533627-xx
Complete with connector (female) and D-sub connector (male) for IK 115/IK 215		310196-xx	324544-xx	524599-xx
With one connector (female)		309777-xx	309778-xx	634265-xx
Cable only		816317-xx	816322-xx	816329-xx
Mating element on connecting cable to connector on encoder cable	Connector (female) for cable Ø 8 mm 	291697-05	291697-26	–
Connector on connecting cable for connection to subsequent electronics	Connector (male) for cable Ø 4.5 mm Ø 8 mm Ø 6 mm 	291697-06 291697-08 291697-07	291697-27	–
Coupling on connecting cable	Coupling (male) for cable Ø 4.5 mm Ø 6 mm Ø 8 mm 	291698-14 291698-03 291698-04	291698-25 291698-26 291698-27	–
Flange socket for mounting on subsequent electronics	Flange socket (female) 	315892-08	315892-10	–
Mounted couplings	With flange (female) Ø 6 mm Ø 8 mm 	291698-17 291698-07	291698-35	–
	With flange (male) Ø 6 mm Ø 8 mm 	291698-08 291698-31	291698-41 291698-29	–
	With central fastener (male) Ø 6 mm to 10 mm 	741045-01	741045-02	–
Adapter $\sim 1\text{ V}_{PP}/11\text{ }\mu\text{A}_{PP}$ For converting the 1 V_{PP} signals to $11\text{ }\mu\text{A}_{PP}$; M23 connector (female, 12-pin) and M23 connector (male, 9-pin)		364914-01	–	–

A_P : Cross section of power supply lines

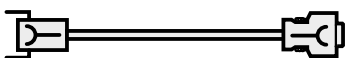
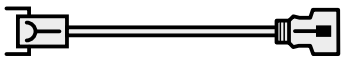
Connecting cables Fanuc Mitsubishi Siemens

		Cable	Fanuc	Mitsubishi
PUR connecting cable for M23 connecting elements				
Complete With 17-pin M23 connector (female) and Fanuc connector [(2 x 2 x 0.14 mm ²) + (4 x 1 mm ²)]; A _P = 1 mm ²		Ø 8 mm	534855-xx	–
Complete With 17-pin M23 connector (female) and 20-pin Mitsubishi connector [(2 x 2 x 0.14 mm ²) + (4 x 0.5 mm ²)]; A _P = 0.5 mm ²	 20-pin	Ø 6 mm	–	367958-xx
Complete With 17-pin M23 connector (female) and 10-pin Mitsubishi connector [(2 x 2 x 0.14 mm ²) + (4 x 1 mm ²)]; A _P = 1 mm ²	 10-pin	Ø 8 mm	–	573661-xx
Cable only [(2 x 2 x 0.14 mm ²) + (4 x 1 mm ²)]; A _P = 1 mm ²		Ø 8 mm	816327-xx	

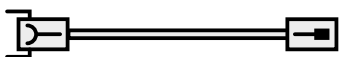
		Cable	Fanuc	Mitsubishi
PUR connecting cable for M12 connecting element [(1 x 4 x 0.14 mm²) + (4 x 0.34 mm²)]; A_P = 0.34 mm²				
Complete With 8-pin M12 connector (female) and Fanuc connector		Ø 6 mm	646807-xx	–
Complete With 8-pin M12 connector (female) and 20-pin Mitsubishi connector	 20-pin	Ø 6 mm	–	646806-xx
Complete With 8-pin M12 connector (female) and 10-pin Mitsubishi connector	 10-pin	Ø 6 mm	–	647314-xx

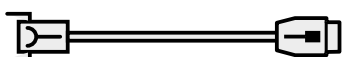
		Cable	Siemens
PUR connecting cable for M12 connecting element [2(2 x 0.17 mm²) + (2 x 0.24 mm²)]; A_P = 0.24 mm²			
Complete With 8-pin M12 connector (female) and 8-pin M12 coupling (male)		Ø 6.8 mm	822504-xx
Complete With 8-pin M12 connector (female) and Siemens RJ45 connector (IP 67) Cable length: 1 m		Ø 6.8 mm	1094652-01
Complete With 8-pin M12 connector (female) and Siemens RJ45 connector (IP 20)		Ø 6.8 mm	1093042-xx

A_P: Cross section of power supply lines

Diagnostic and testing equipment

HEIDENHAIN encoders are provided with all information necessary for commissioning, monitoring and diagnostics. The type of available information depends on whether the encoder is incremental or absolute and which interface is used.

Incremental encoders mainly have 1 V_{PP}, TTL or HTL interfaces. TTL and HTL encoders monitor their signal amplitudes internally and generate a simple fault detection signal. With 1 V_{PP} signals, the analysis of output signals is possible only in external test devices or through computation in the subsequent electronics (analog diagnostics interface).

Absolute encoders operate with serial data transfer. Depending on the interface, additional 1 V_{PP} incremental signals can be output. The signals are monitored comprehensively within the encoder. The monitoring result (especially with valuation numbers) can be transferred along with the position value through the serial interface to the subsequent electronics (digital diagnostics interface). The following information is available:

- Error message: Position value not reliable
- Warning: An internal functional limit of the encoder has been reached
- Valuation numbers:
 - Detailed information on the encoder's functional reserve
 - Identical scaling for all HEIDENHAIN encoders
 - Cyclic output is possible

This enables the subsequent electronics to evaluate the current status of the encoder at little cost even in closed-loop mode.

HEIDENHAIN offers the appropriate PWM inspection devices and PWT test devices for encoder analysis. There are two types of diagnostics, depending on how they are integrated:

- Encoder diagnostics: The encoder is connected directly to the test or inspection device. This makes a comprehensive analysis of encoder functions possible.
- Diagnostics in the control loop: The PWM phase meter is looped into the closed control loop (e.g. through a suitable testing adapter). This makes a real-time diagnosis of the machine or system possible during operation. The functions depend on the interface.

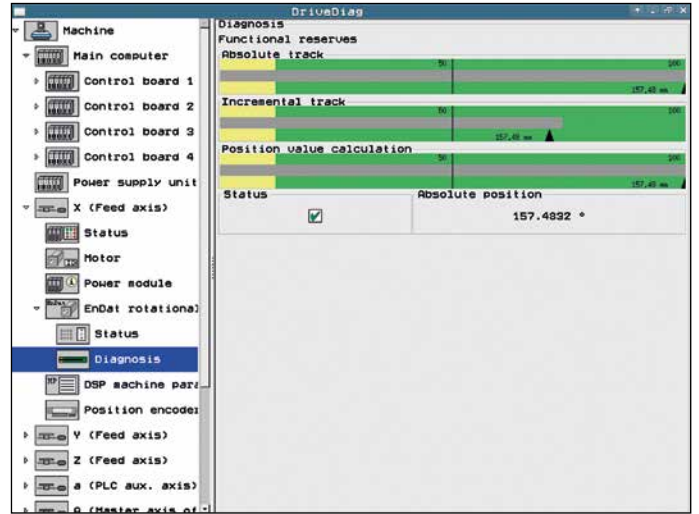

Diagnostics in the control loop on HEIDENHAIN controls with display of the valuation number or the analog encoder signals

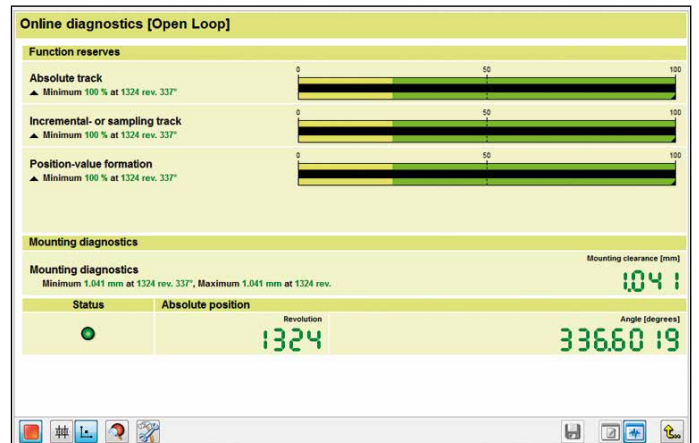

Diagnostics using PWM 20 and ATS software

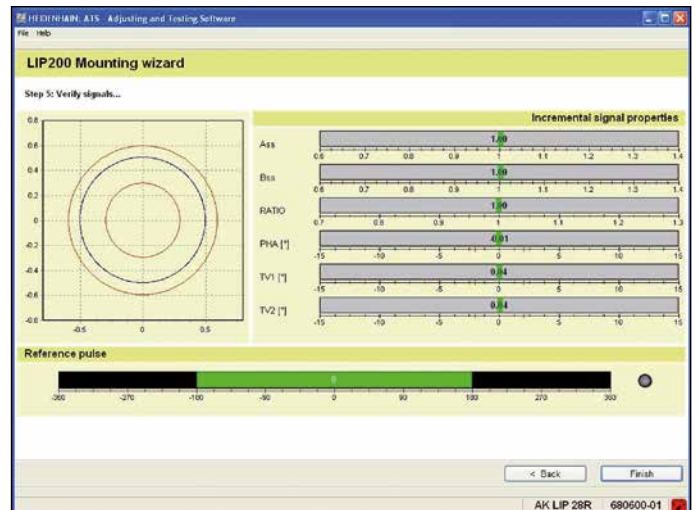

Commissioning using PWM 20 and ATS software

PWM 20

The PWM 20 phase angle measuring unit serves together with the provided ATS adjusting and testing software for diagnosis and adjustment of HEIDENHAIN encoders.



	PWM 20
Encoder input	<ul style="list-style-type: none"> • EnDat 2.1 or EnDat 2.2 (absolute value with/without incremental signals) • DRIVE-CLiQ • Fanuc Serial Interface • Mitsubishi high speed interface • Yaskawa Serial Interface • SSI • 1 V_{PP}/TTL/11 μApp
Interface	USB 2.0
Voltage supply	100 V to 240 V AC or 24 V DC
Dimensions	258 mm x 154 mm x 55 mm

	ATS
Languages	Choice between English and German
Functions	<ul style="list-style-type: none"> • Position display • Connection dialog • Diagnostics • Mounting wizard for EBI/ECI/EQI, LIP 200, LIC 4000 and others • Additional functions (if supported by the encoder) • Memory contents
System requirements and recommendations	PC (dual-core processor, > 2 GHz) RAM > 2 GB Windows operating systems XP, Vista, 7 (32-bit/64-bit), 8 200 MB free space on hard disk

DRIVE-CLiQ is a registered trademark of Siemens Aktiengesellschaft

The **PWM 9** is a universal measuring device for checking and adjusting HEIDENHAIN incremental encoders. Expansion modules are available for checking the various types of encoder signals. The values can be read on an LCD monitor. Soft keys provide ease of operation.



	PWM 9
Inputs	Expansion modules (interface boards) for 11 μApp; 1 V _{PP} ; TTL; HTL; EnDat*/SSI*/commutation signals *No display of position values or parameters
Functions	<ul style="list-style-type: none"> • Measures signal amplitudes, current consumption, operating voltage, scanning frequency • Graphically displays incremental signals (amplitudes, phase angle and on-off ratio) and the reference-mark signal (width and position) • Displays symbols for the reference mark, fault-detection signal, counting direction • Universal counter, interpolation selectable from single to 1024-fold • Adjustment support for exposed linear encoders
Outputs	<ul style="list-style-type: none"> • Inputs are connected through to the subsequent electronics • BNC sockets for connection to an oscilloscope
Voltage supply	10 V to 30 V DC, max. 15 W
Dimensions	150 mm x 205 mm x 96 mm

Interface electronics

Interface electronics from HEIDENHAIN adapt the encoder signals to the interface of the subsequent electronics. They are used when the subsequent electronics cannot directly process the output signals from HEIDENHAIN encoders, or if additional interpolation of the signals is necessary.

Input signals of the interface electronics

Interface electronics from HEIDENHAIN can be connected to encoders with sinusoidal signals of 1 V_{PP} (voltage signals) or 11 μA_{PP} (current signals). Encoders with the serial interfaces EnDat or SSI can also be connected to various interface electronics.

Output signals of the interface electronics

Interface electronics with the following interfaces to the subsequent electronics are available:

- TTL square-wave pulse trains
- EnDat 2.2
- DRIVE-CLiQ
- Fanuc serial interface
- Mitsubishi high speed interface
- Yaskawa serial interface
- Profibus

Interpolation of the sinusoidal input signals

In addition to being converted, the sinusoidal encoder signals are also interpolated in the interface electronics. This permits finer measuring steps and, as a result, higher control quality and better positioning behavior.

Formation of a position value

Some interface electronics have an integrated counting function. Starting from the last reference point set, an absolute position value is formed when the reference mark is traversed, and is transferred to the subsequent electronics.

Box design



Plug design



Version for integration



Top-hat rail design



Outputs		Inputs		Design – Protection class	Interpolation ¹⁾ or subdivision	Model		
Interface	Qty.	Interface	Qty.					
□ TTL	1	~ 1 V _{PP}	1	Box design – IP 65	5/10-fold	IBV 101		
					20/25/50/100-fold	IBV 102		
					Without interpolation	IBV 600		
				25/50/100/200/400-fold	IBV 660B			
				Plug design – IP 40	5/10/20/25/50/100-fold	APE 371		
				Version for integration – IP 00	5/10-fold	IDP 181		
		20/25/50/100-fold	IDP 182					
		~ 11 μA _{PP}	1		1	Box design – IP 65	5/10-fold	EXE 101
							20/25/50/100-fold	EXE 102
							Without/5-fold	EXE 602E
25/50/100/200/400-fold	EXE 660B							
Version for integration – IP 00	5-fold	IDP 101						
□ TTL/ ~ 1 V _{PP} Adjustable	2	~ 1 V _{PP}	1	Box design – IP 65	2-fold	IBV 6072		
					5/10-fold	IBV 6172		
					5/10-fold and 20/25/50/100-fold	IBV 6272		
EnDat 2.2	1	~ 1 V _{PP}	1	Box design – IP 65	≤ 16384-fold subdivision	EIB 192		
				Plug design – IP 40	≤ 16384-fold subdivision	EIB 392		
			2	Box design – IP 65	≤ 16384-fold subdivision	EIB 1512		
DRIVE-CLiQ	1	EnDat 2.2	1	Box design – IP 65	–	EIB 2391S		
Fanuc Serial Interface	1	~ 1 V _{PP}	1	Box design – IP 65	≤ 16384-fold subdivision	EIB 192F		
				Plug design – IP 40	≤ 16384-fold subdivision	EIB 392F		
			2	Box design – IP 65	≤ 16384-fold subdivision	EIB 1592F		
Mitsubishi high speed interface	1	~ 1 V _{PP}	1	Box design – IP 65	≤ 16384-fold subdivision	EIB 192M		
				Plug design – IP 40	≤ 16384-fold subdivision	EIB 392M		
			2	Box design – IP 65	≤ 16384-fold subdivision	EIB 1592M		
Yaskawa Serial Interface	1	EnDat 2.2 ²⁾	1	Plug design – IP 40	–	EIB 3391Y		
PROFIBUS-DP	1	EnDat 2.1; EnDat 2.2	1	Top-hat rail design	–	PROFIBUS Gateway		

¹⁾ Switchable

²⁾ Only LIC 4100 measuring step 5 nm, LIC 2100 measuring step 50 nm and 100 nm

HEIDENHAIN

DR. JOHANNES HEIDENHAIN GmbH

Dr.-Johannes-Heidenhain-Straße 5

83301 Traunreut, Germany

☎ +49 8669 31-0

FAX +49 8669 5061

E-mail: info@heidenhain.de

www.heidenhain.de

Vollständige und weitere Adressen siehe www.heidenhain.de
For complete and further addresses see www.heidenhain.de

DE	HEIDENHAIN Vertrieb Deutschland 83301 Traunreut, Deutschland ☎ 08669 31-3132 FAX 08669 32-3132 E-Mail: hd@heidenhain.de	ES	FARRESA ELECTRONICA S.A. 08028 Barcelona, Spain www.farresa.es	PL	APS 02-384 Warszawa, Poland www.heidenhain.pl
	HEIDENHAIN Technisches Büro Nord 12681 Berlin, Deutschland ☎ 030 54705-240	FI	HEIDENHAIN Scandinavia AB 02770 Espoo, Finland www.heidenhain.fi	PT	FARRESA ELECTRÓNICA, LDA. 4470 - 177 Maia, Portugal www.farresa.pt
	HEIDENHAIN Technisches Büro Mitte 07751 Jena, Deutschland ☎ 03641 4728-250	FR	HEIDENHAIN FRANCE sarl 92310 Sèvres, France www.heidenhain.fr	RO	HEIDENHAIN Reprezentantă Romania Braşov, 500407, Romania www.heidenhain.ro
	HEIDENHAIN Technisches Büro West 44379 Dortmund, Deutschland ☎ 0231 618083-0	GB	HEIDENHAIN (G.B.) Limited Burgess Hill RH15 9RD, United Kingdom www.heidenhain.co.uk	RS	Serbia → BG
	HEIDENHAIN Technisches Büro Südwest 70771 Leinfelden-Echterdingen, Deutschland ☎ 0711 993395-0	GR	MB Milionis Vassilis 17341 Athens, Greece www.heidenhain.gr	RU	OOO HEIDENHAIN 115172 Moscow, Russia www.heidenhain.ru
	HEIDENHAIN Technisches Büro Südost 83301 Traunreut, Deutschland ☎ 08669 31-1345	HK	HEIDENHAIN LTD Kowloon, Hong Kong E-mail: sales@heidenhain.com.hk	SE	HEIDENHAIN Scandinavia AB 12739 Skärholmen, Sweden www.heidenhain.se
		HR	Croatia → SL	SG	HEIDENHAIN PACIFIC PTE LTD. Singapore 408593 www.heidenhain.com.sg
AR	NAKASE SRL. B1653AOX Villa Ballester, Argentina www.heidenhain.com.ar	HU	HEIDENHAIN Kereskedelmi Képviselet 1239 Budapest, Hungary www.heidenhain.hu	SK	KOPRETINA TN s.r.o. 91101 Trenčín, Slovakia www.kopretina.sk
AT	HEIDENHAIN Techn. Büro Österreich 83301 Traunreut, Germany www.heidenhain.de	ID	PT Servitama Era Toolsindo Jakarta 13930, Indonesia E-mail: ptset@group.gts.co.id	SL	NAVO d.o.o. 2000 Maribor, Slovenia www.heidenhain.si
AU	FCR Motion Technology Pty. Ltd Laverton North 3026, Australia E-mail: vicsales@fcrmotion.com	IL	NEUMO VARGUS MARKETING LTD. Tel Aviv 61570, Israel E-mail: neumo@neumo-vargus.co.il	TH	HEIDENHAIN (THAILAND) LTD Bangkok 10250, Thailand www.heidenhain.co.th
BE	HEIDENHAIN NV/SA 1760 Roosdaal, Belgium www.heidenhain.be	IN	HEIDENHAIN Optics & Electronics India Private Limited Chetpet, Chennai 600 031, India www.heidenhain.in	TR	T&M Mühendislik San. ve Tic. LTD. ŞTİ. 34728 Ümraniye-Istanbul, Turkey www.heidenhain.com.tr
BG	ESD Bulgaria Ltd. Sofia 1172, Bulgaria www.esd.bg	IT	HEIDENHAIN ITALIANA S.r.l. 20128 Milano, Italy www.heidenhain.it	TW	HEIDENHAIN Co., Ltd. Taichung 40768, Taiwan R.O.C. www.heidenhain.com.tw
BR	DIADUR Indústria e Comércio Ltda. 04763-070 – São Paulo – SP, Brazil www.heidenhain.com.br	JP	HEIDENHAIN K.K. Tokyo 102-0083, Japan www.heidenhain.co.jp	UA	Gertner Service GmbH Büro Kiev 01133 Kiev, Ukraine www.heidenhain.ua
BY	GERTNER Service GmbH 220026 Minsk, Belarus www.heidenhain.by	KR	HEIDENHAIN Korea LTD. Gasan-Dong, Seoul, Korea 153-782 www.heidenhain.co.kr	US	HEIDENHAIN CORPORATION Schaumburg, IL 60173-5337, USA www.heidenhain.com
CA	HEIDENHAIN CORPORATION Mississauga, Ontario L5T2N2, Canada www.heidenhain.com	MX	HEIDENHAIN CORPORATION MEXICO 20235 Aguascalientes, Ags., Mexico E-mail: info@heidenhain.com	VE	Maquinaria Diekmann S.A. Caracas, 1040-A, Venezuela E-mail: purchase@diekmann.com.ve
CH	HEIDENHAIN (SCHWEIZ) AG 8603 Schwerzenbach, Switzerland www.heidenhain.ch	MY	ISOSERVE SDN. BHD. 43200 Balakong, Selangor E-mail: isoserve@po.jaring.my	VN	AMS Co. Ltd HCM City, Vietnam E-mail: davidgoh@amsvn.com
CN	DR. JOHANNES HEIDENHAIN (CHINA) Co., Ltd. Beijing 101312, China www.heidenhain.com.cn	NL	HEIDENHAIN NEDERLAND B.V. 6716 BM Ede, Netherlands www.heidenhain.nl	ZA	MAFEMA SALES SERVICES C.C. Midrand 1685, South Africa www.heidenhain.co.za
CZ	HEIDENHAIN s.r.o. 102 00 Praha 10, Czech Republic www.heidenhain.cz	NO	HEIDENHAIN Scandinavia AB 7300 Orkanger, Norway www.heidenhain.no		
DK	TPTEKNIK A/S 2670 Greve, Denmark www.tp-gruppen.dk	PH	Machinebanks Corporation Quezon City, Philippines 1113 E-mail: info@machinebanks.com		

