

ABOUT THIS MANUAL

Wiring and Circuit Diagrams

The diagrams either show entire systems or specific circuits. The circuit specific diagrams only show the components and wiring in the system(s) listed in the diagram title. Always refer to the diagram title for diagram type.

Troubleshooting

Once a problem has been isolated to a specific system or circuit, the circuit specific diagrams will simplify locating the problem.

NOTE

Harness part numbers may be included on some wiring diagrams. Use these numbers for reference purposes only. ALWAYS REFER TO THE PARTS CATALOG WHEN ORDERING WIRE HARNESES.

2012 Harley-Davidson Sportster Models Service Manual (99484-12)

Main Harness: 2012 Sportster.....	1
Engine Management: 2012 Sportster.....	2
Starting and Charging Circuit: 2012 Sportster.....	3
Lighting (1 of 2): 2012 Sportster.....	4
Lighting (2 of 2): 2012 Sportster.....	5
Instrument, Indicators, and Hand Controls: 2012 Sportster.....	6
Security Circuit: 2012 Sportster.....	7
Security Circuit with Anti-Theft Tracking Module: 2012 Sportster.....	8

2012 Harley-Davidson Softail Models Service Manual (99482-12)

Front Lighting and Hand Controls: 2012 Softail.....	9
Main Harness 1 of 2: 2012 Softail (Except FXS).....	10
Main Harness 2 of 2: 2012 Softail (Except FXS).....	11
Main Harness 1 of 2: 2012 Softail (FXS).....	12
Main Harness 2 of 2: 2012 Softail (FXS).....	13
Rear Lighting: 2012 Softail.....	14

2012 Harley-Davidson Dyna Models Service Manual (99481-12)

Front Lighting and Hand Controls: 2012 Dyna.....	15
Main Harness 1 of 2: 2012 Dyna.....	16
Main Harness 2 of 2: 2012 Dyna.....	17
Rear Lighting: 2012 Dyna.....	18

2012 Harley-Davidson VRSC Models Service Manual (99501-12)

Main Harness (1 of 3): 2012 VRSC with ABS.....	19
Main Harness (2 of 3): 2012 VRSC without ABS.....	20
Main Harness and Charging Circuit (3 of 3): 2012 VRSC.....	21
Ignition Circuit: 2012 VRSC.....	22
Starting Circuit: 2012 VRSC.....	23
ABS Circuit: 2012 VRSC.....	24
Lighting Circuit: 2012 VRSC.....	25
Horn and Instrument Circuit: 2012 VRSC.....	26
Security Circuit Without Anti-Theft Tracking Module: 2012 VRSC.....	27
Security Circuit With Anti-Theft Tracking Module: 2012 VRSC.....	28

2012 Harley-Davidson Touring Models Service Manual (99483-12)

Left GND1: 2012 Touring (Except FLHR/C).....	29
Main Harness (1 OF 5): 2012 Touring (Except FLHR/C) without ABS.....	30
Main Harness (2 OF 5): 2012 Touring (Except FLHR/C) with ABS.....	31
Main Harness (3 OF 5): 2012 Touring (FLHR/C) without ABS.....	32

Main Harness (4 OF 5): 2012 Touring (FLHR/C) with ABS.....	33
Main Harness (5 OF 5): 2012 Touring.....	34
Fairing Harness: 2012 Touring.....	35
Indicators, Fairing Switches, Handlebar Switches: 2012 Touring.....	36
Starting Circuit: 2012 Touring.....	37
Rear Lighting, Charging System: 2012 Touring.....	38
Front Lighting, Console Harness, ABS: 2012 Touring.....	39
Security Circuit: 2012 Touring.....	40
Security Circuit: 2012 Touring With Anti-Theft Tracking Module.....	41
Ultra Radio RF Interconnect Circuit: 2012 Touring.....	42
Classic Radio Circuit: 2012 Touring.....	43
Ultra Radio Circuit: 2012 Touring.....	44
2-Place Intercom and Headset Audio: 2012 Touring.....	45
CAN and Module Audio Inputs to Ultra Radio: 2012 Touring.....	46

2012 Harley-Davidson Police Models Service Manual Supplement (99855-12)

Main Harness (1 of 3): 2012 FLHTP.....	47
Main Harness (2 of 3): 2012 FLHTP.....	48
Main Harness (3 of 3): 2012 FLHTP, FLHP.....	49
Fairing Harness: 2012 FLHTP.....	50
Lighting: 2012 FLHTP, FLHP.....	51
Starting and Charging: 2012 FLHTP, FLHP.....	52
Indicators, Fairing Switch and Handlebar Switches: 2012 FLHTP, FLHP.....	53
ABS and Siren Amplifier: 2012 FLHTP, FLHP.....	54
Security Circuit: 2012 FLHTP, FLHP.....	55
Strobe System: 2012 FLHTP, FLHP.....	56

2012 Harley-Davidson FLSTSE3 Model Service Manual Supplement (99494-12)

Main Wiring Harness (1 of 2): 2012 FLSTSE3.....	57
Main Wiring Harness (2 of 2): 2012 FLSTSE3.....	58
Lighting: 2012 FLSTSE3.....	59

2012 Harley-Davidson FLHTCUSE7 Model Service Manual Supplement (99500-12)

Main Harness (1 of 2): 2012 FLHTCUSE7.....	61
Main Harness (2 of 2): 2012 FLHTCUSE7.....	62
Fairing Harness: 2012 FLHTCUSE7.....	63
Lighting, Garage Door Opener: 2012 FLHTCUSE7.....	64
Starting and Charging System: 2012 FLHTCUSE7.....	65
Indicators, Fairing Switches, Handlebar Switches, ABS: 2012 FLHTCUSE7.....	66
Audio Overlay Harness: 2012 FLHTCUSE7.....	67

2012 Harley-Davidson FLTRXSE Model Service Manual Supplement (99525-12)

Main Harness (1 of 2): 2012 FLTRXSE.....	69
Main Harness (2 of 2): 2012 FLTRXSE.....	70
Fairing Harness: 2012 FLTRXSE.....	71
Rear Lighting: 2012 FLTRXSE.....	72
Audio, ABS: 2012 FLTRXSE.....	73

2012 Harley-Davidson FLHXSE3 Model Service Manual Supplement (99600-12)

Main Wiring Harness (1 of 2): 2012 FLHXSE3.....	75
Main Wiring Harness (2 of 2): 2012 FLHXSE3.....	76
Fairing Harness: 2012 FLHXSE3.....	77
ABS, Indicator Lamps and Rear Lighting: 2012 FLHXSE3.....	78
Audio: 2012 FLHXSE3.....	79

2012 Harley-Davidson Trike Models Service Manual Supplement (99601-12)

Main Harness (1 of 2): 2012 Trike Models.....81
Main Harness (2 of 2): 2012 Trike Models.....82
Fairing Harness: 2012 Trike Models.....83
Reverse, Rear Lighting: 2012 Trike Models.....84

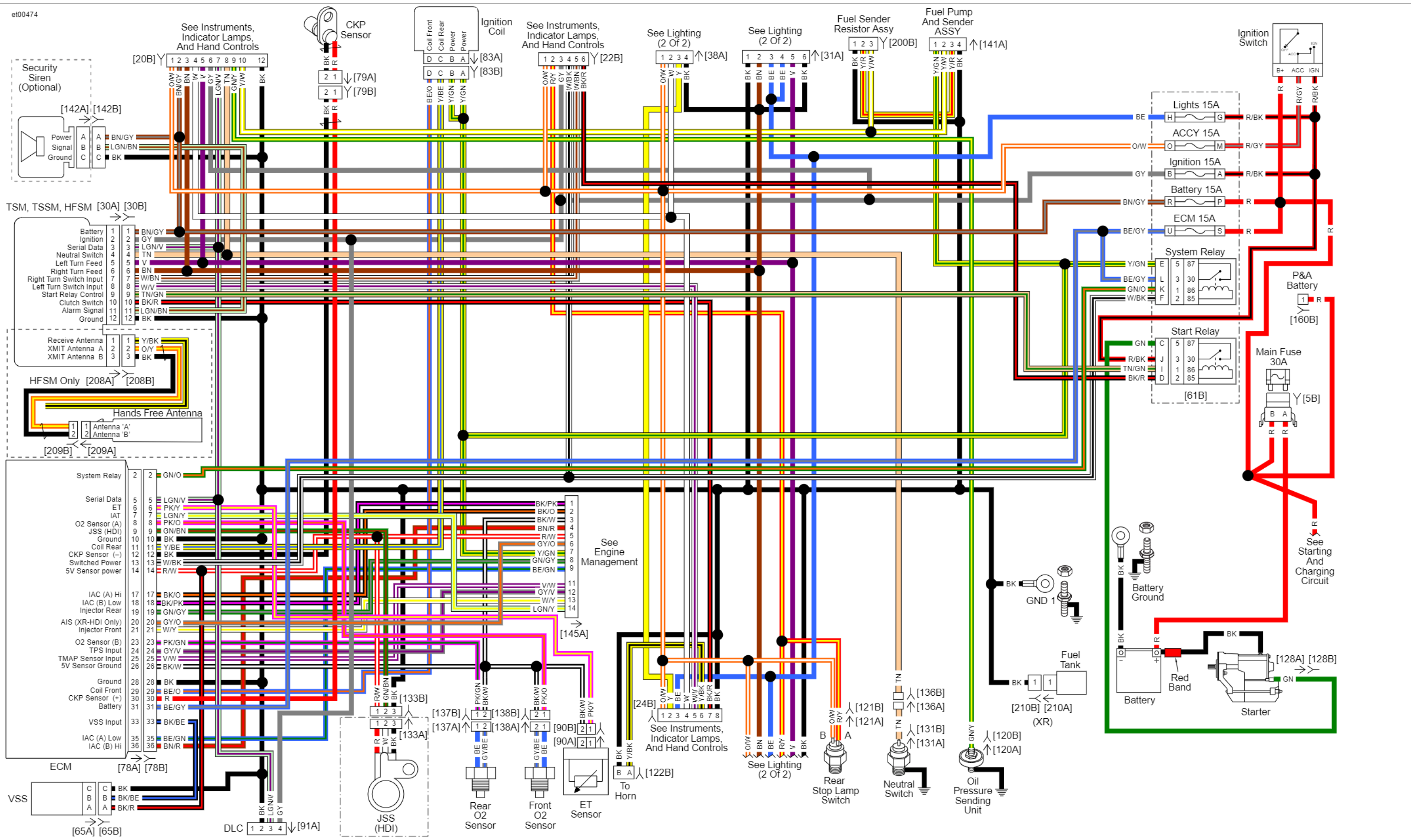

Main Harness: 2012 Sportster

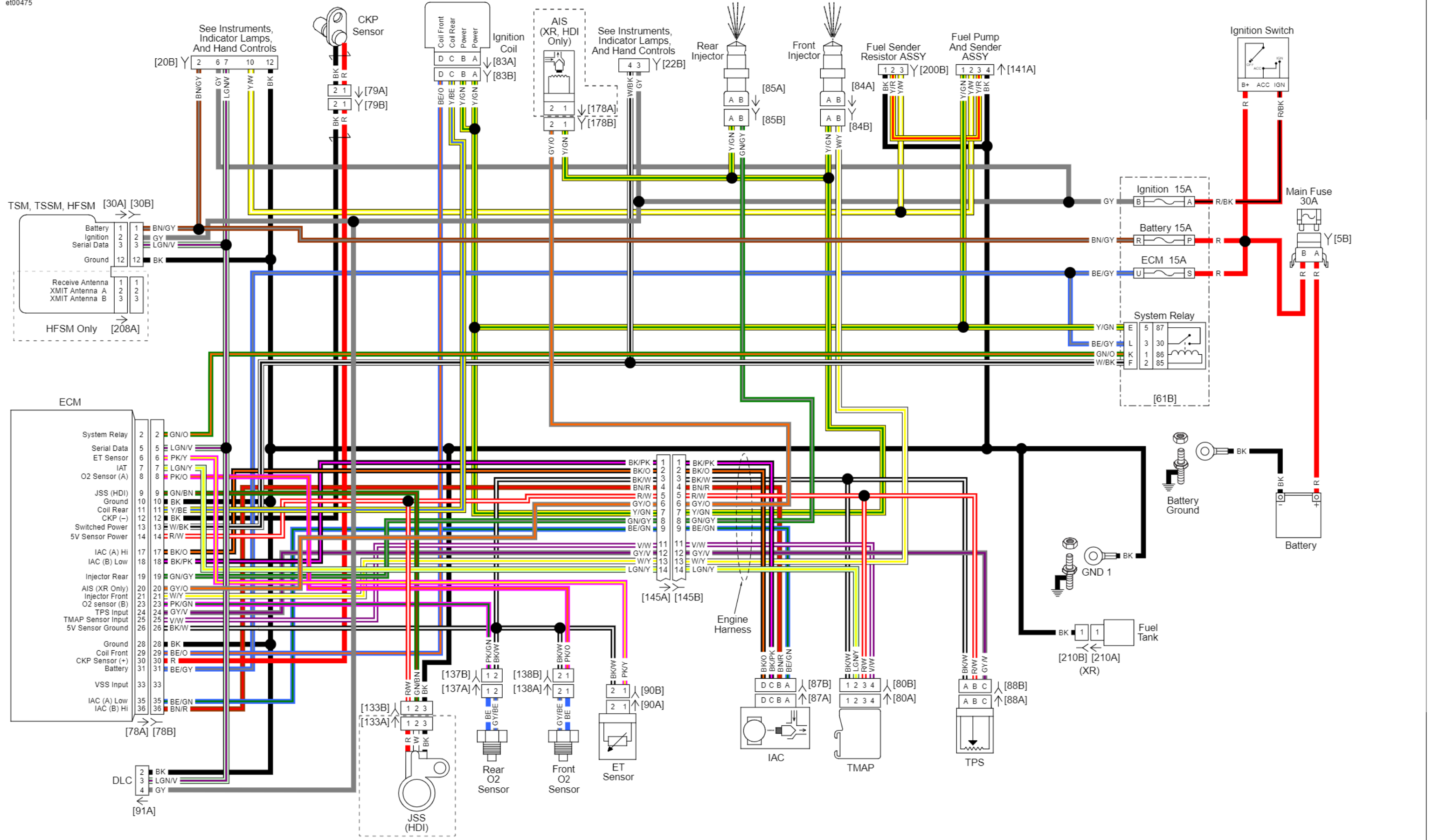

Engine Management: 2012 Sportster

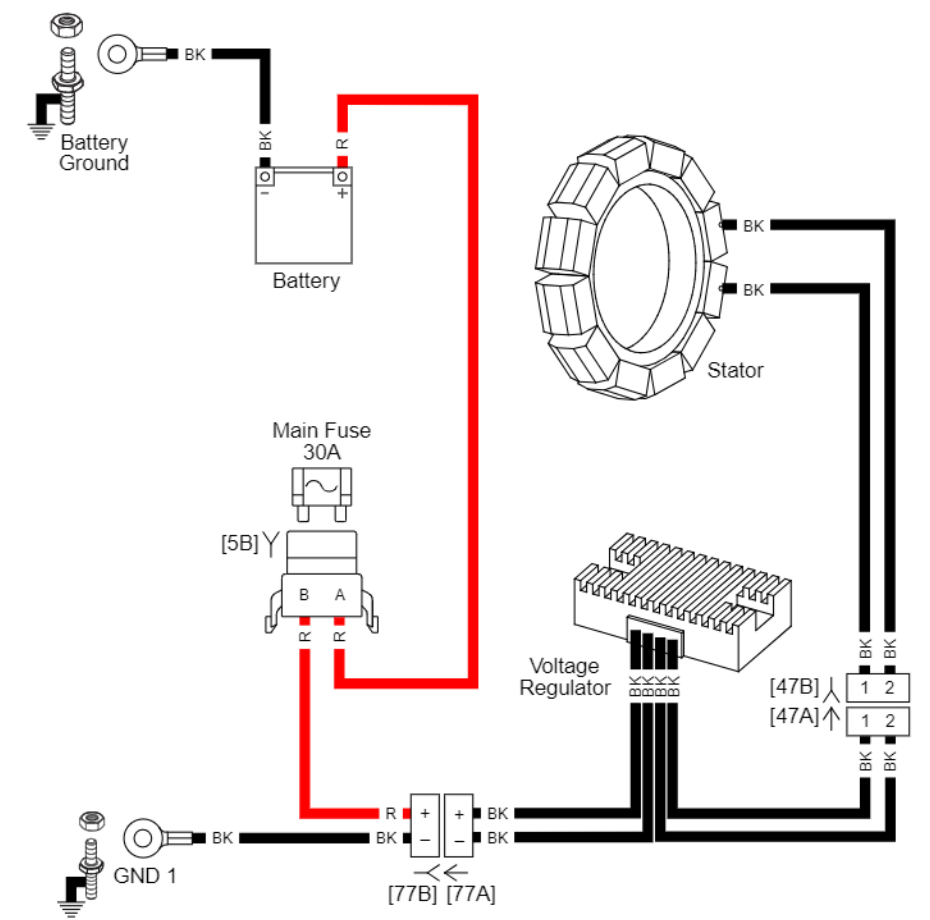
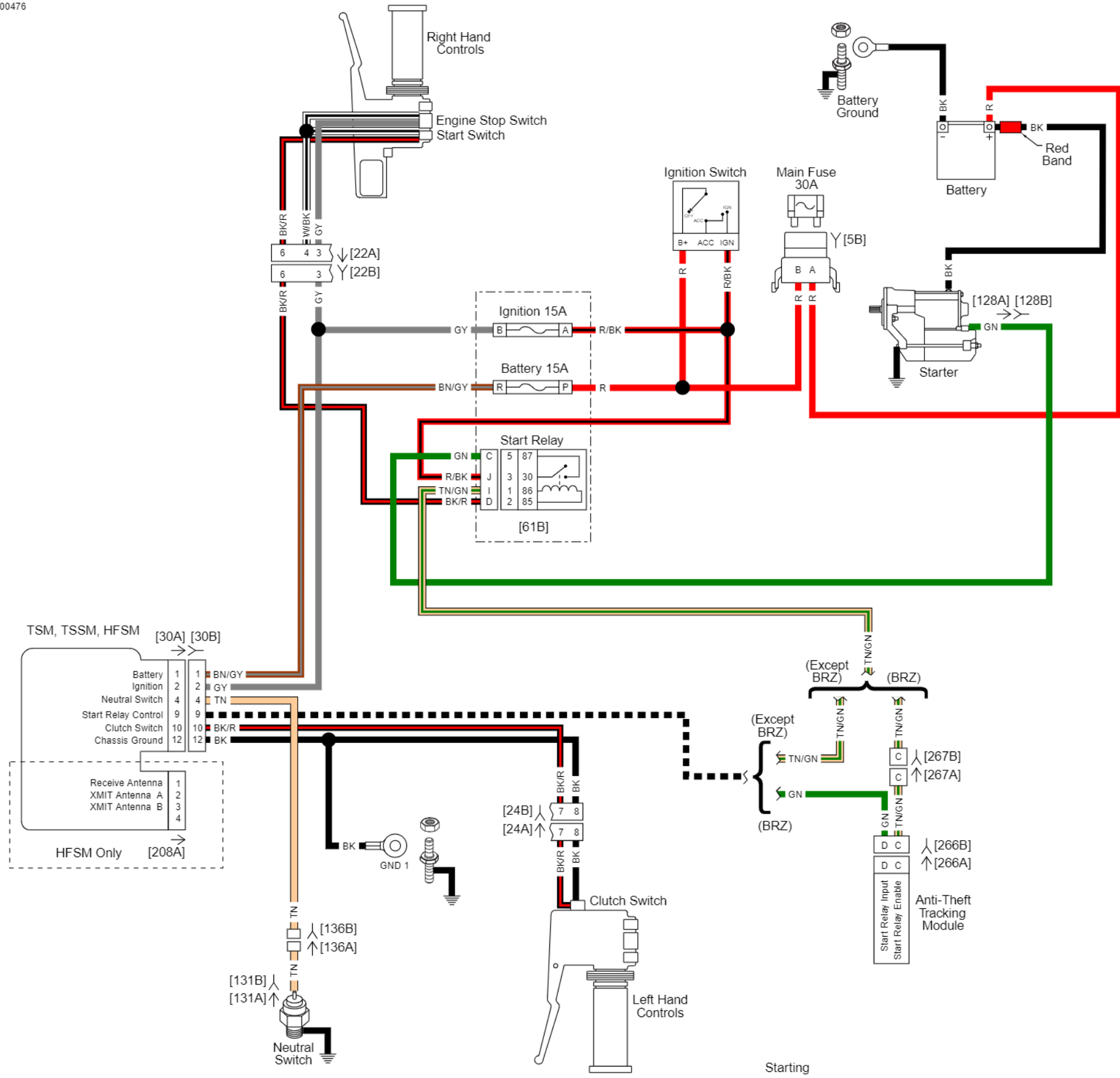

Starting and Charging Circuit: 2012 Sportster

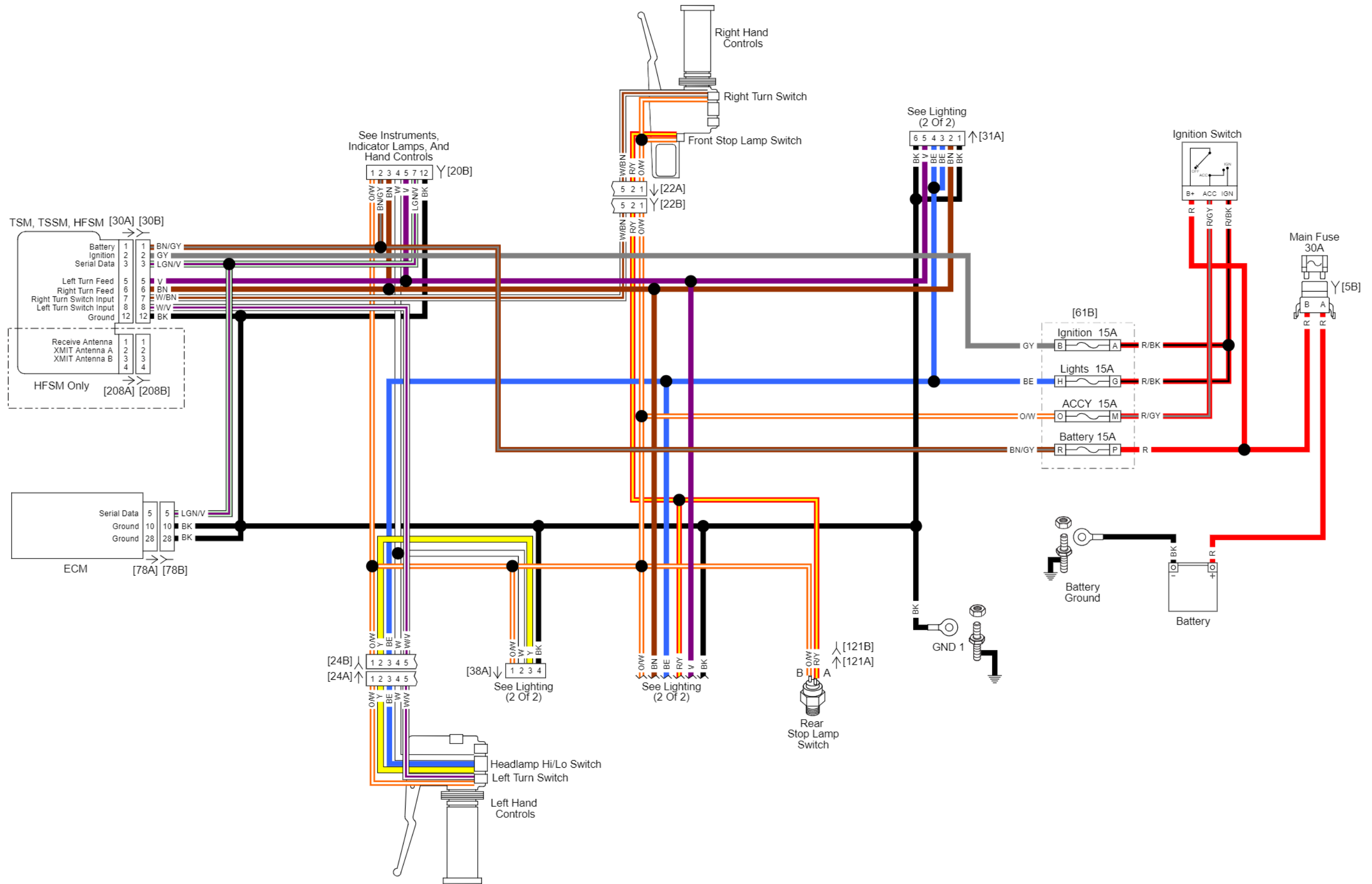

Lighting (1 of 2): 2012 Sportster

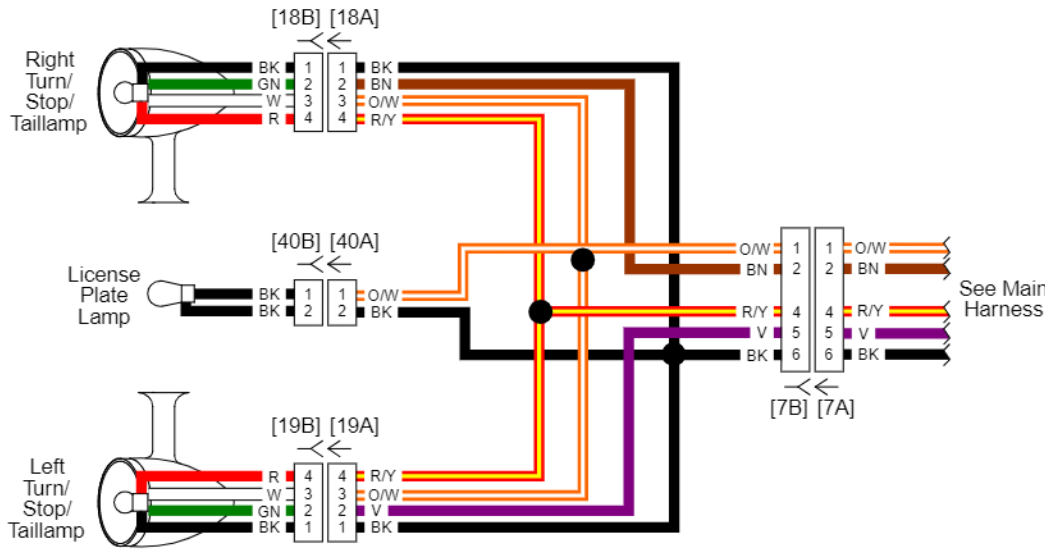
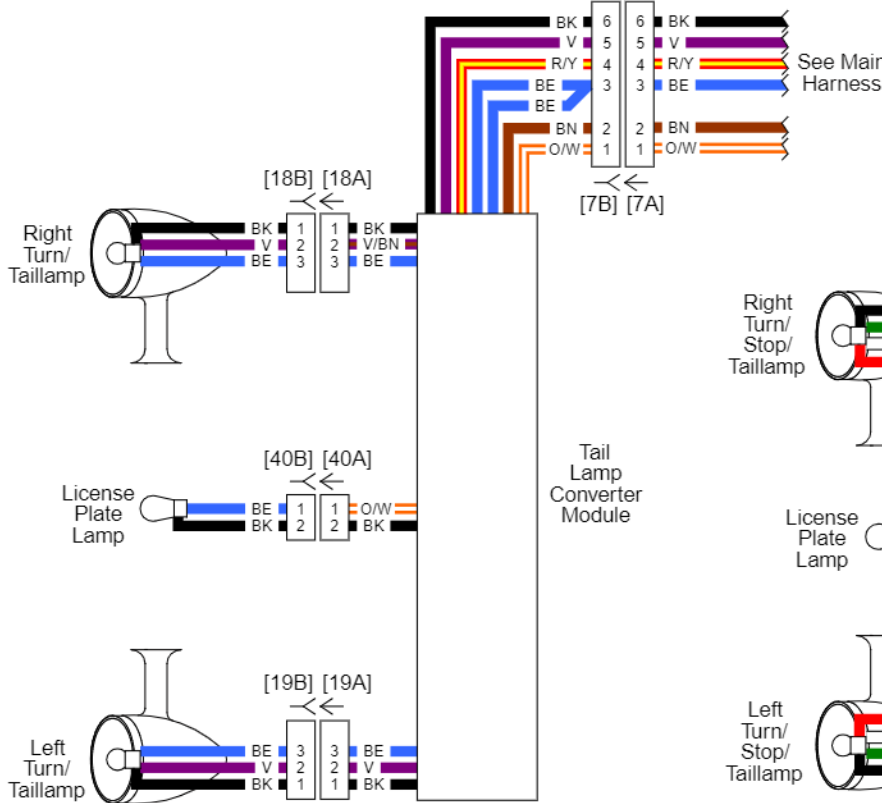
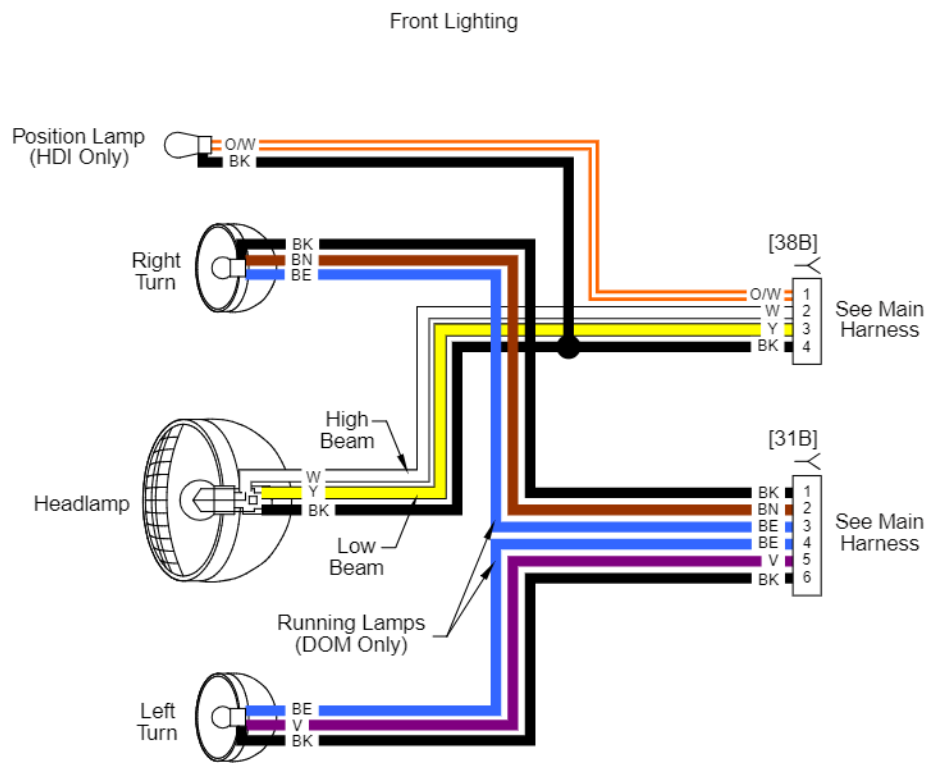

Dual Stop Lamp (DOM)

Dual Stop Lamp (Except DOM)

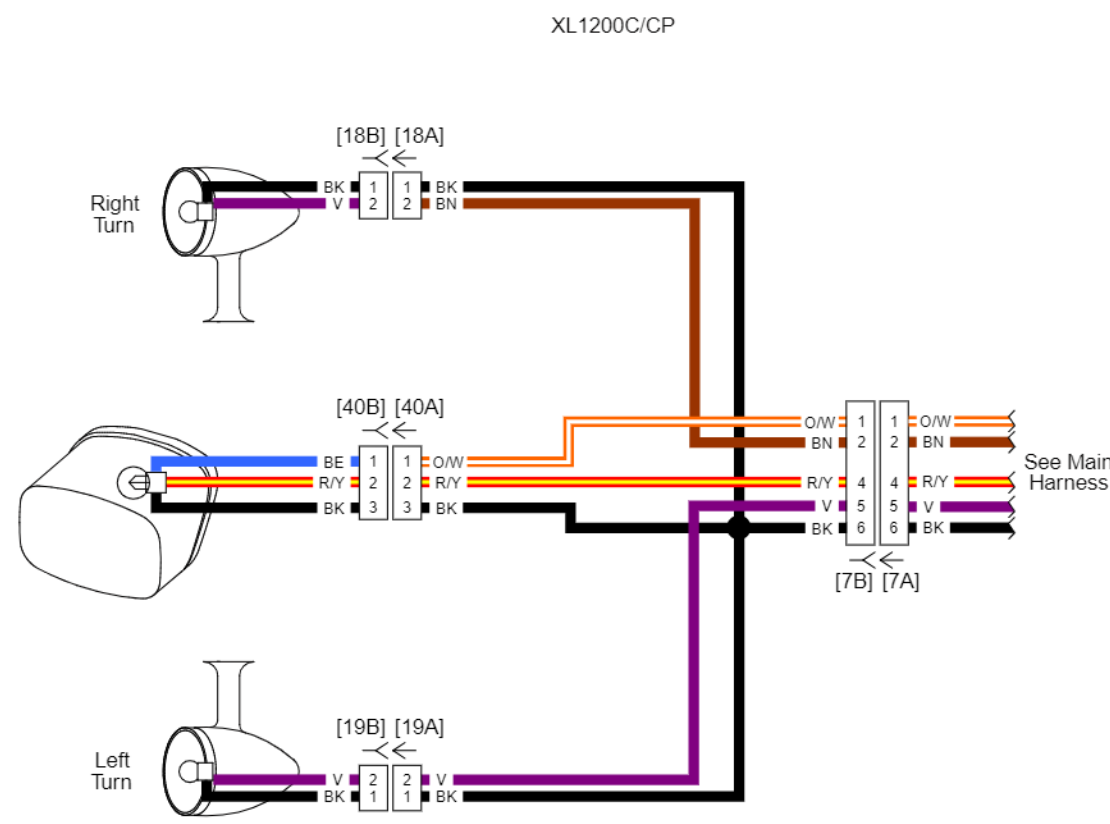
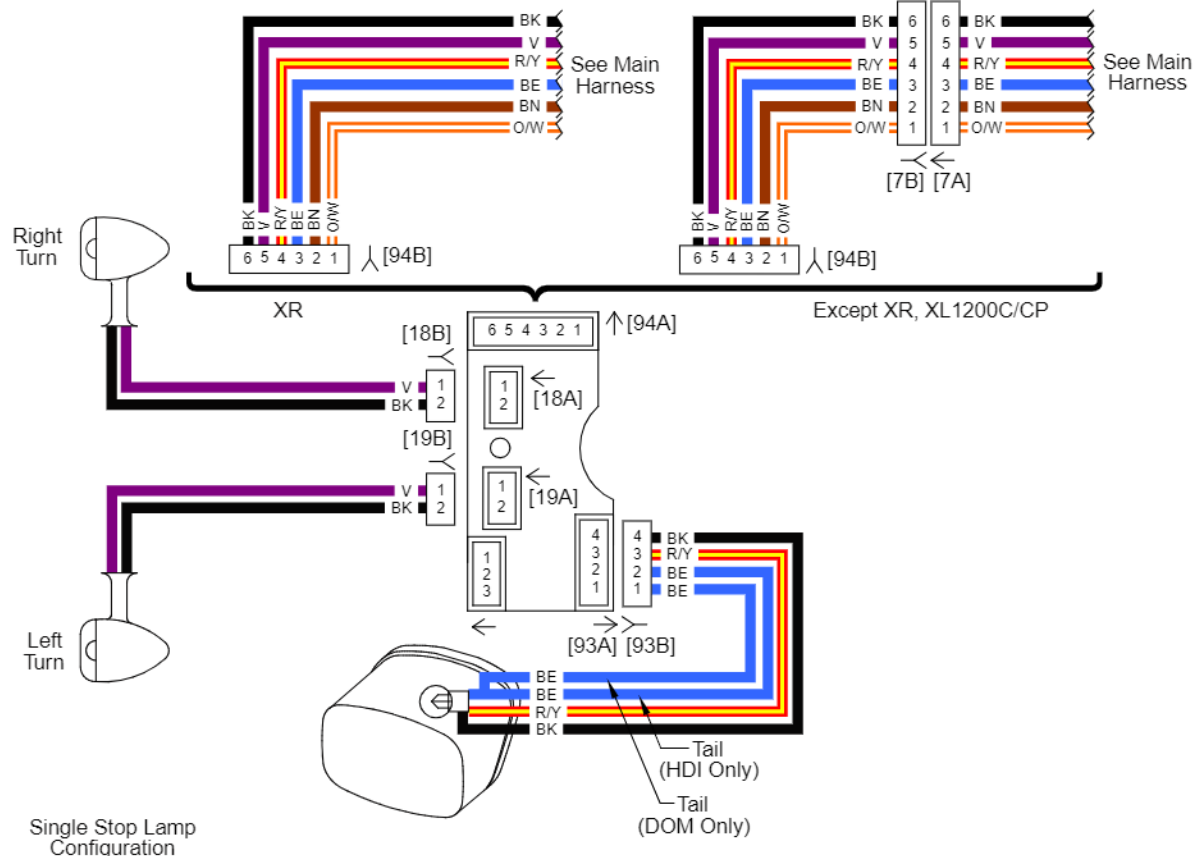

Lighting (2 of 2): 2012 Sportster

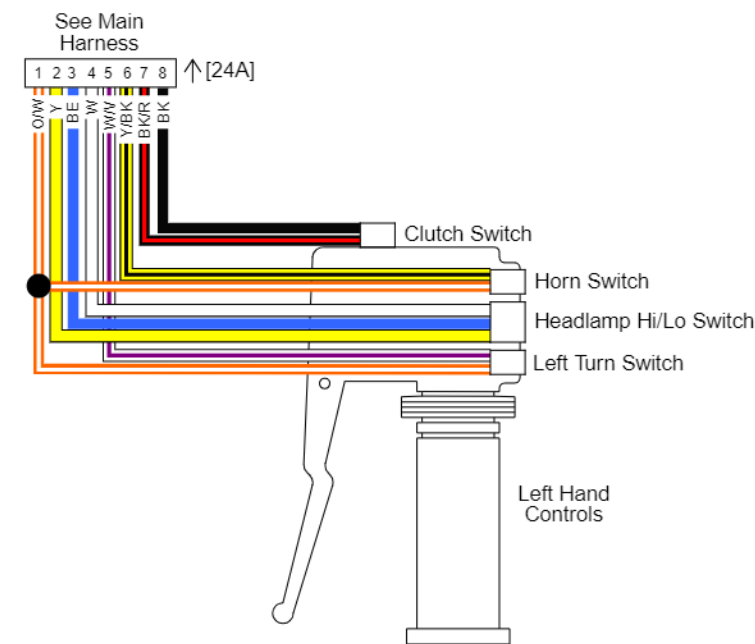
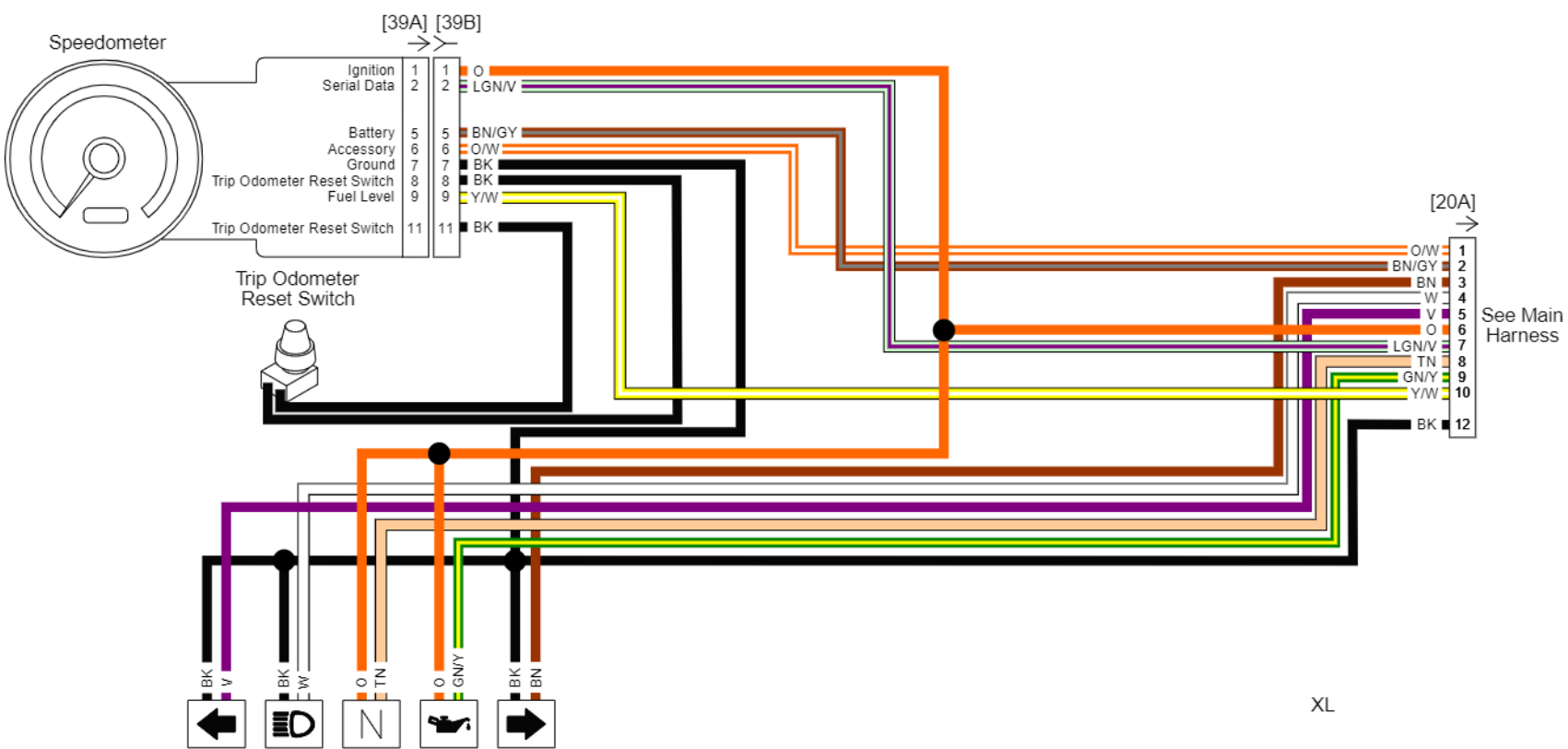
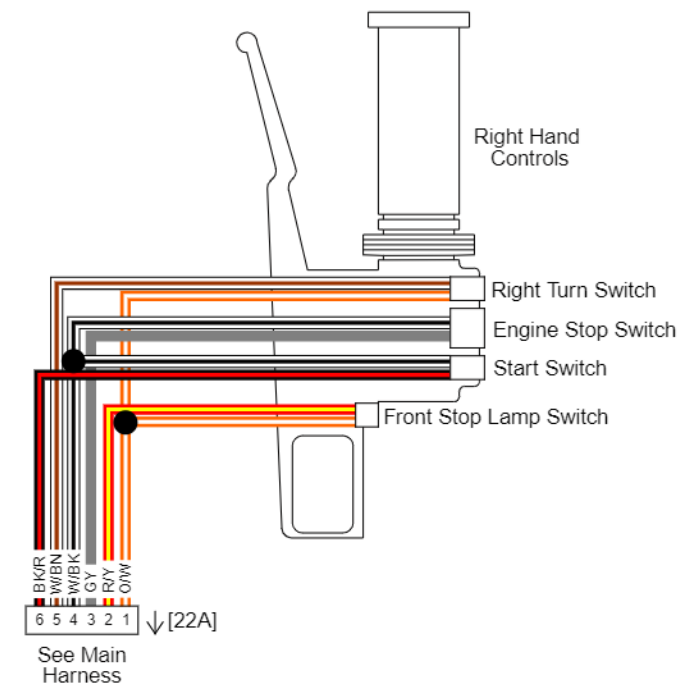
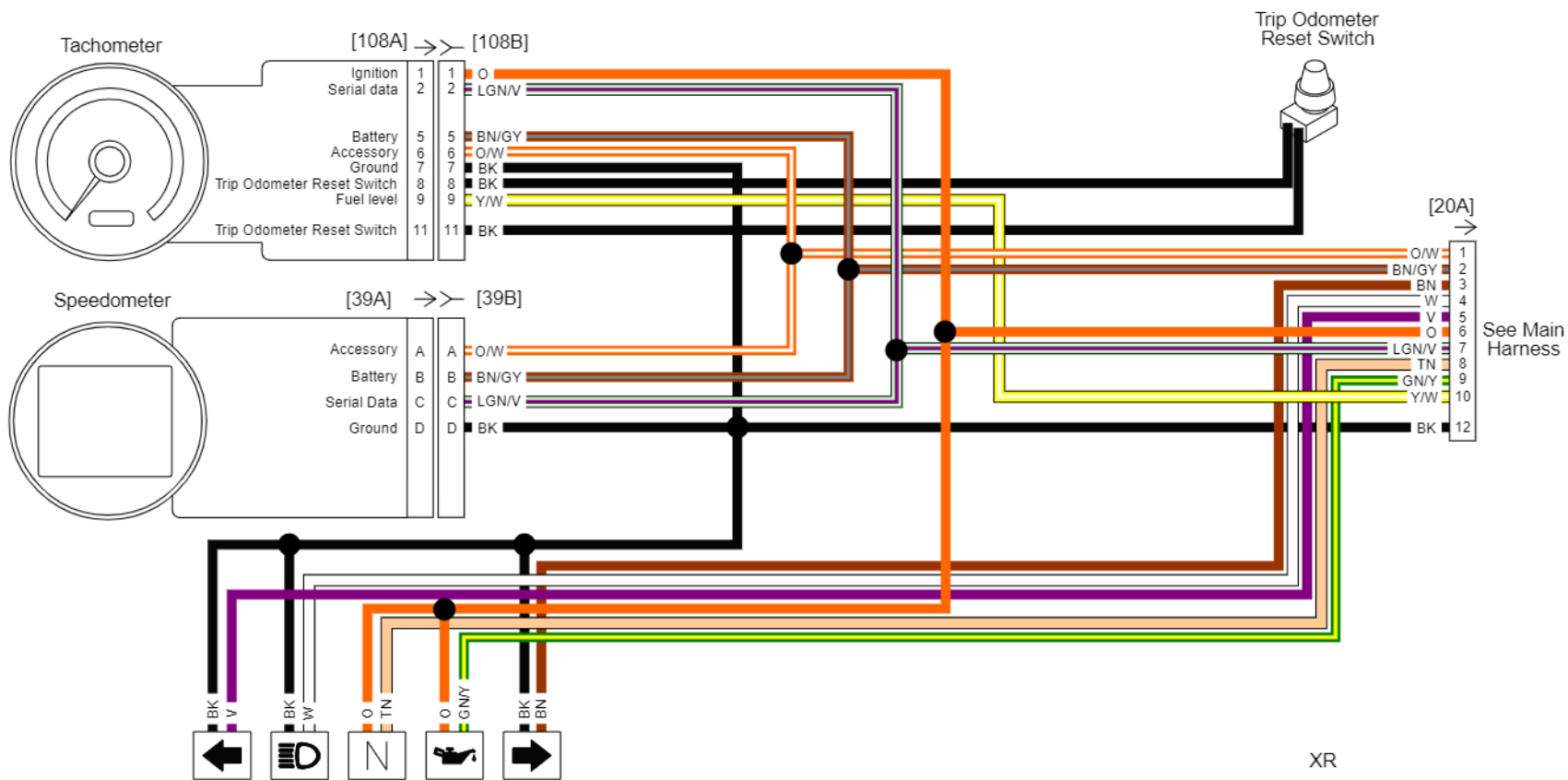

Instrument, Indicators, and Hand Controls: 2012 Sportster

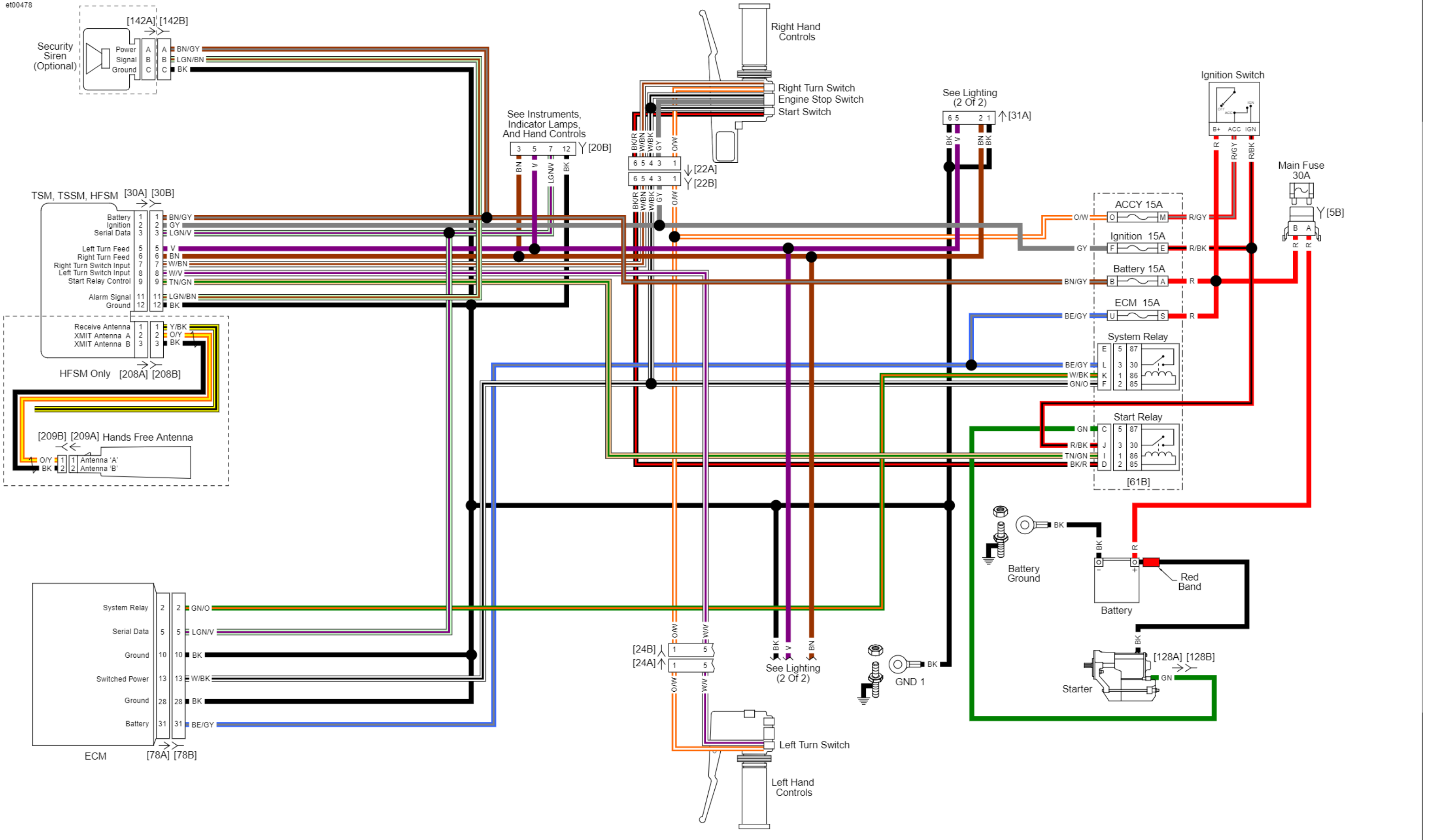

Security Circuit: 2012 Sportster

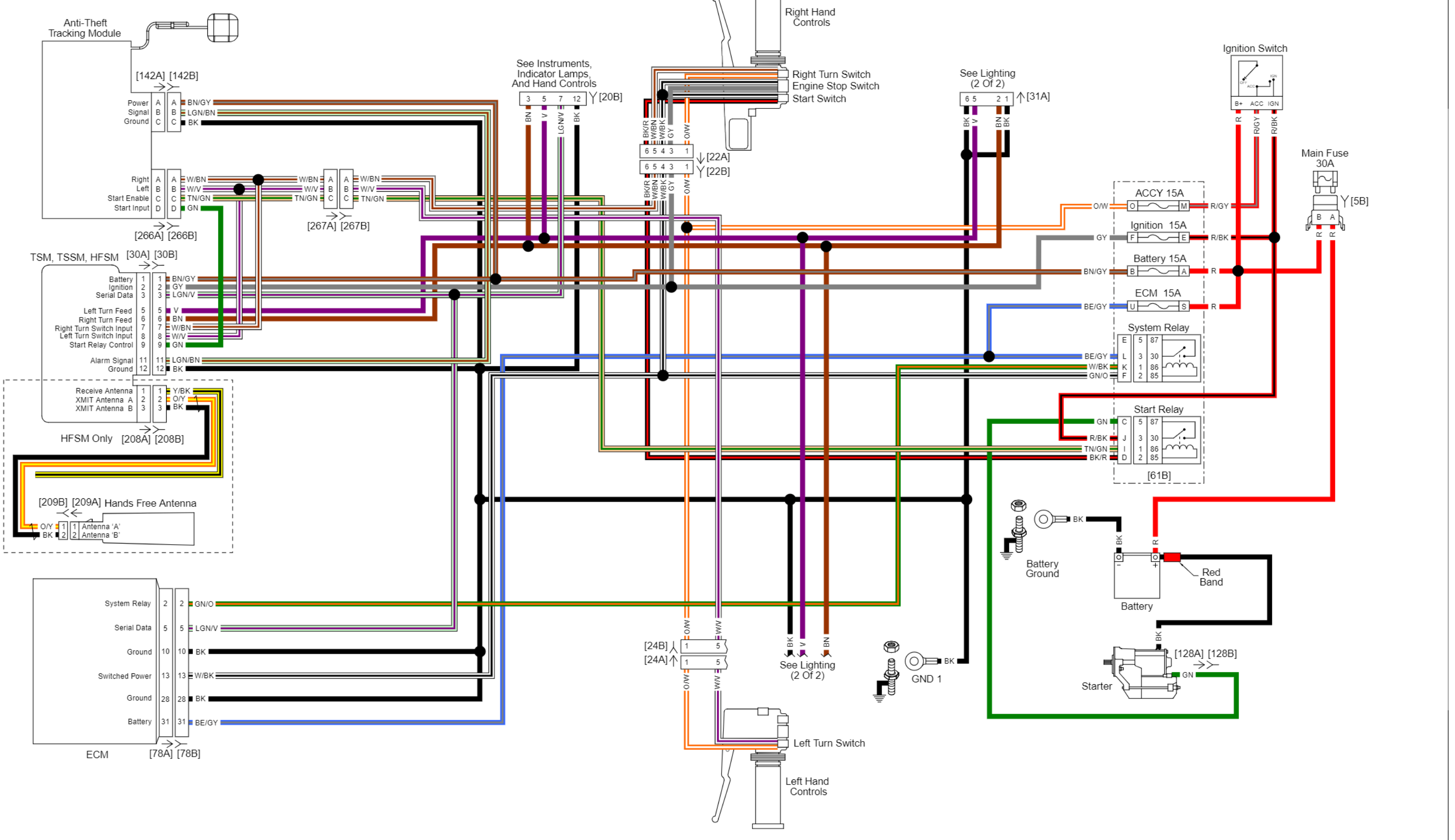

Security Circuit with Anti-Theft Tracking Module: 2012 Sportster

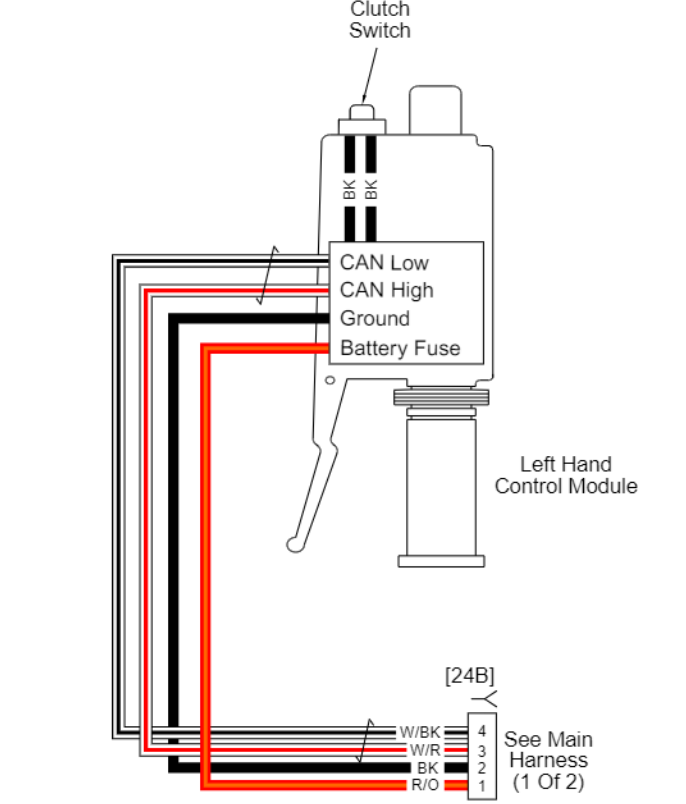
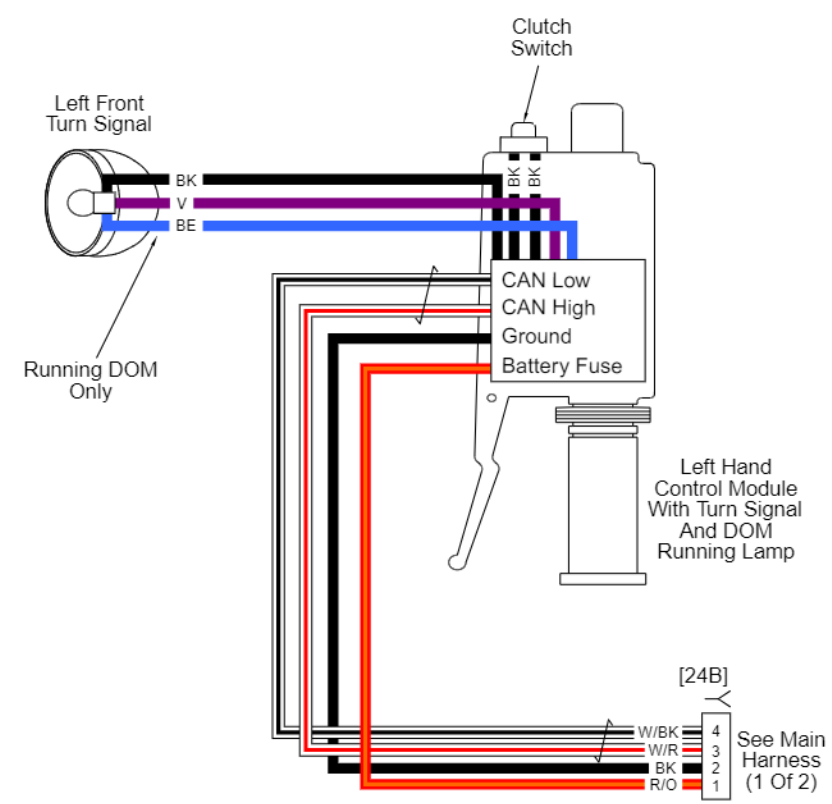
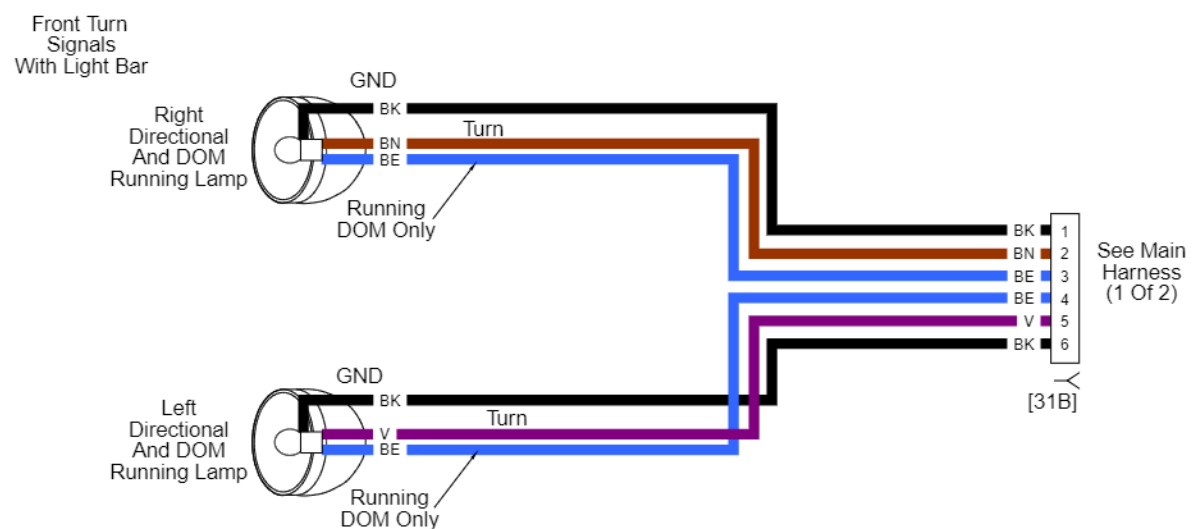
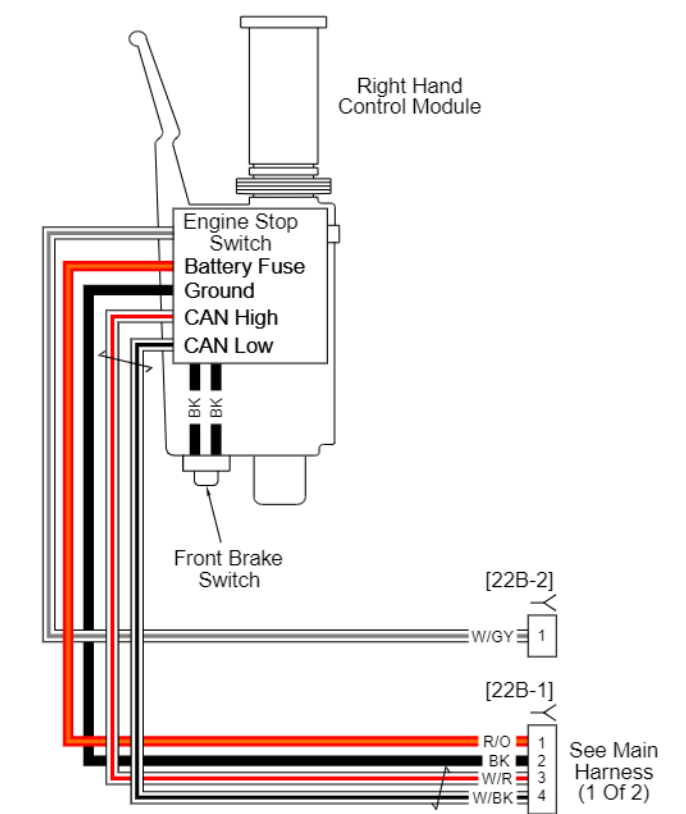
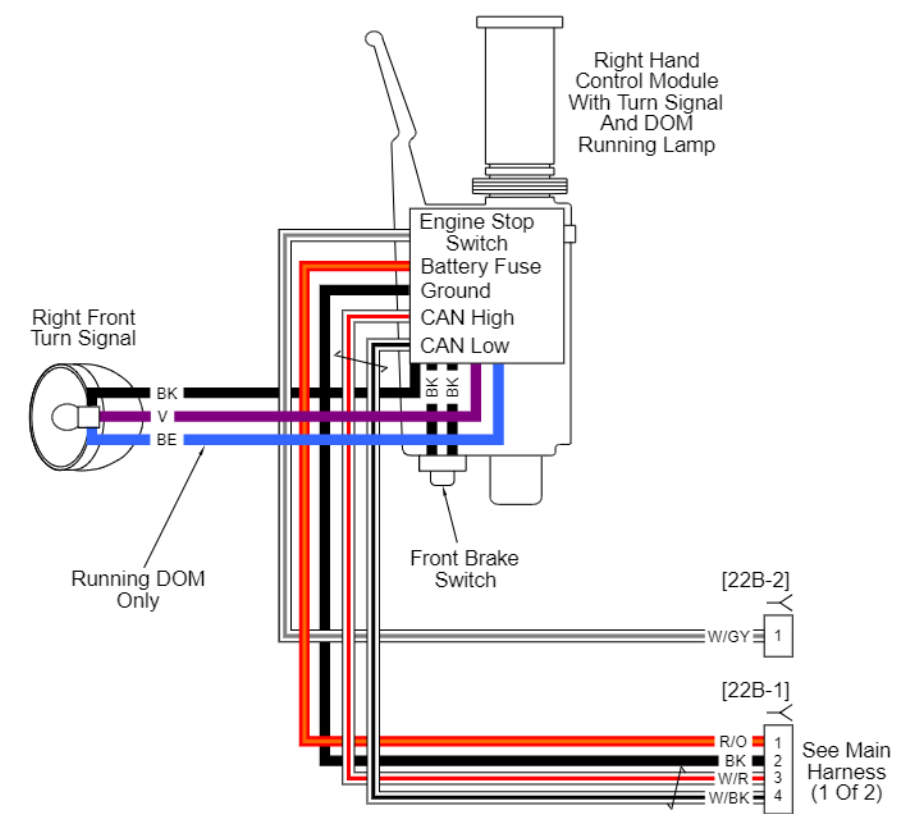
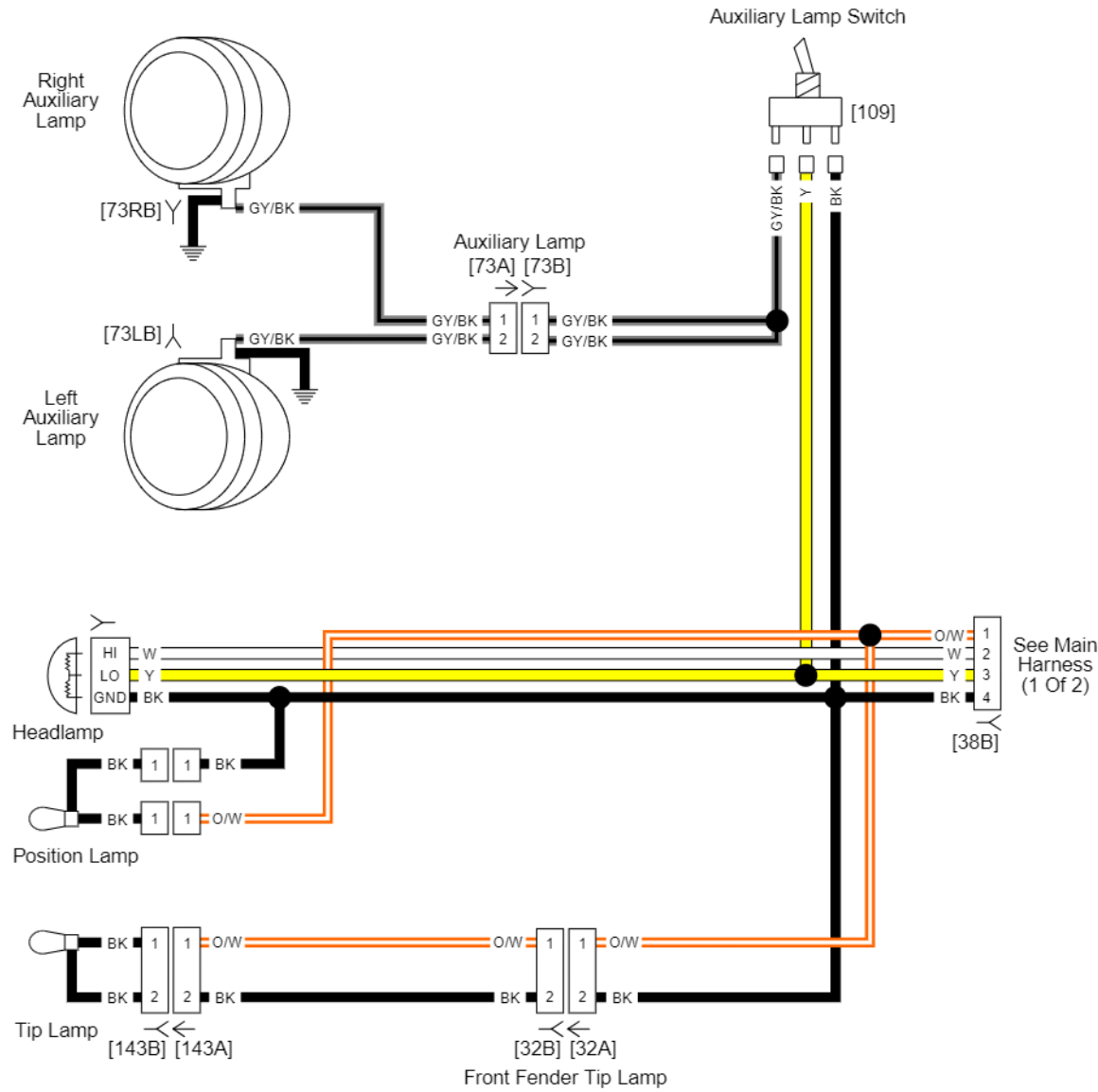

Front Lighting and Hand Controls: 2012 Softail

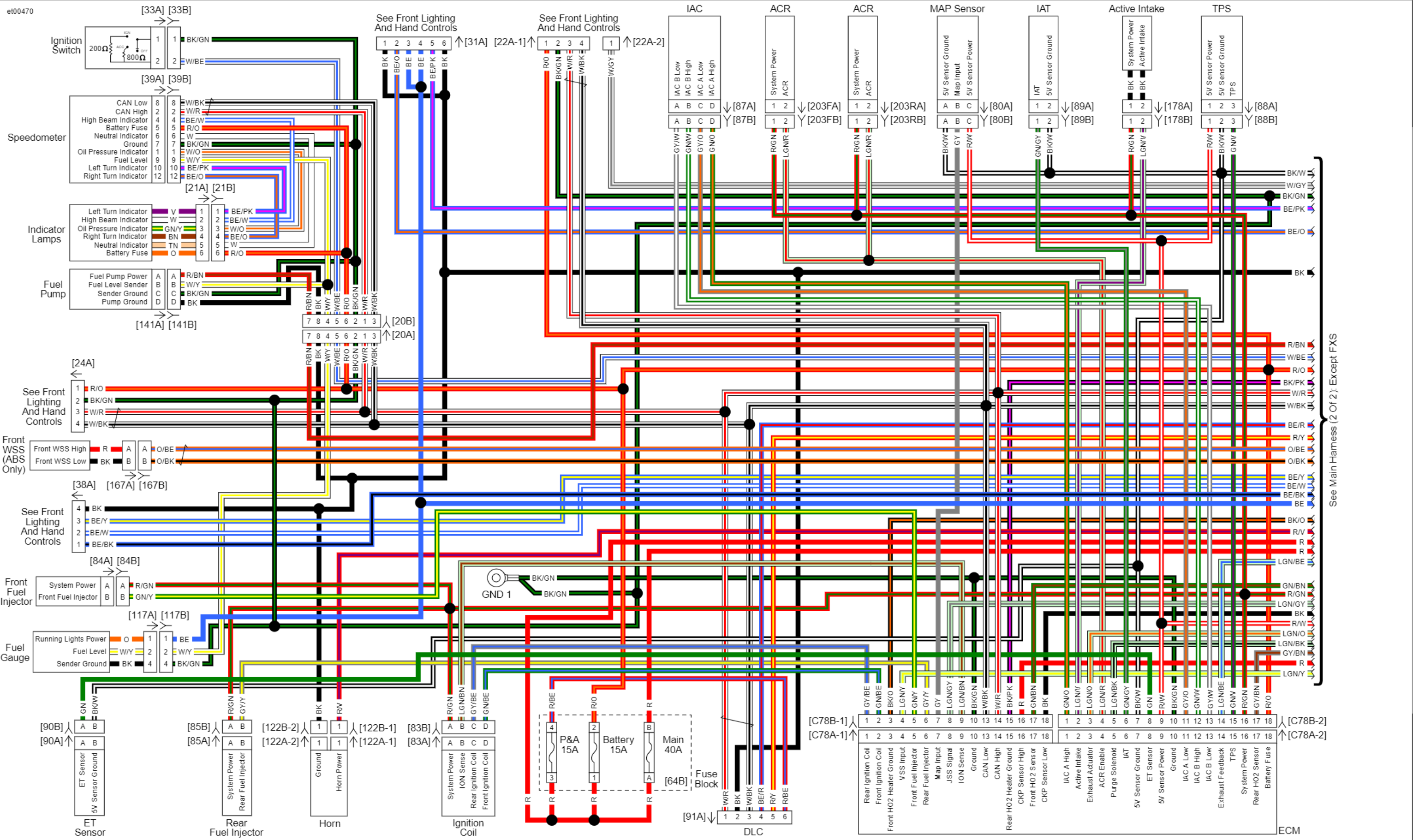

Main Harness 1 of 2: 2012 Softail (Except FXS)

See Main Harness (1 Of 2): Except FXS

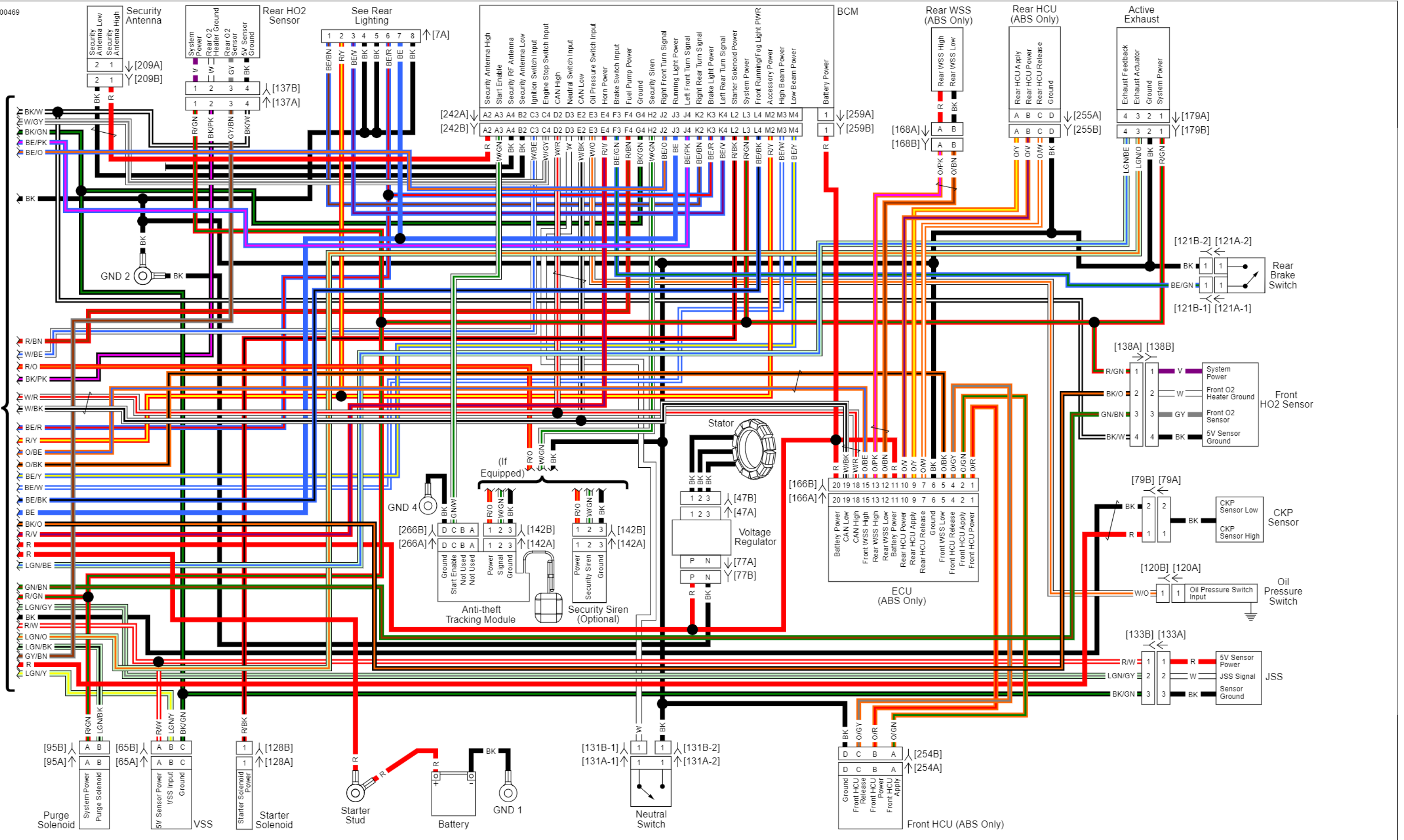

Main Harness 2 of 2: 2012 Softail (Except FXS)

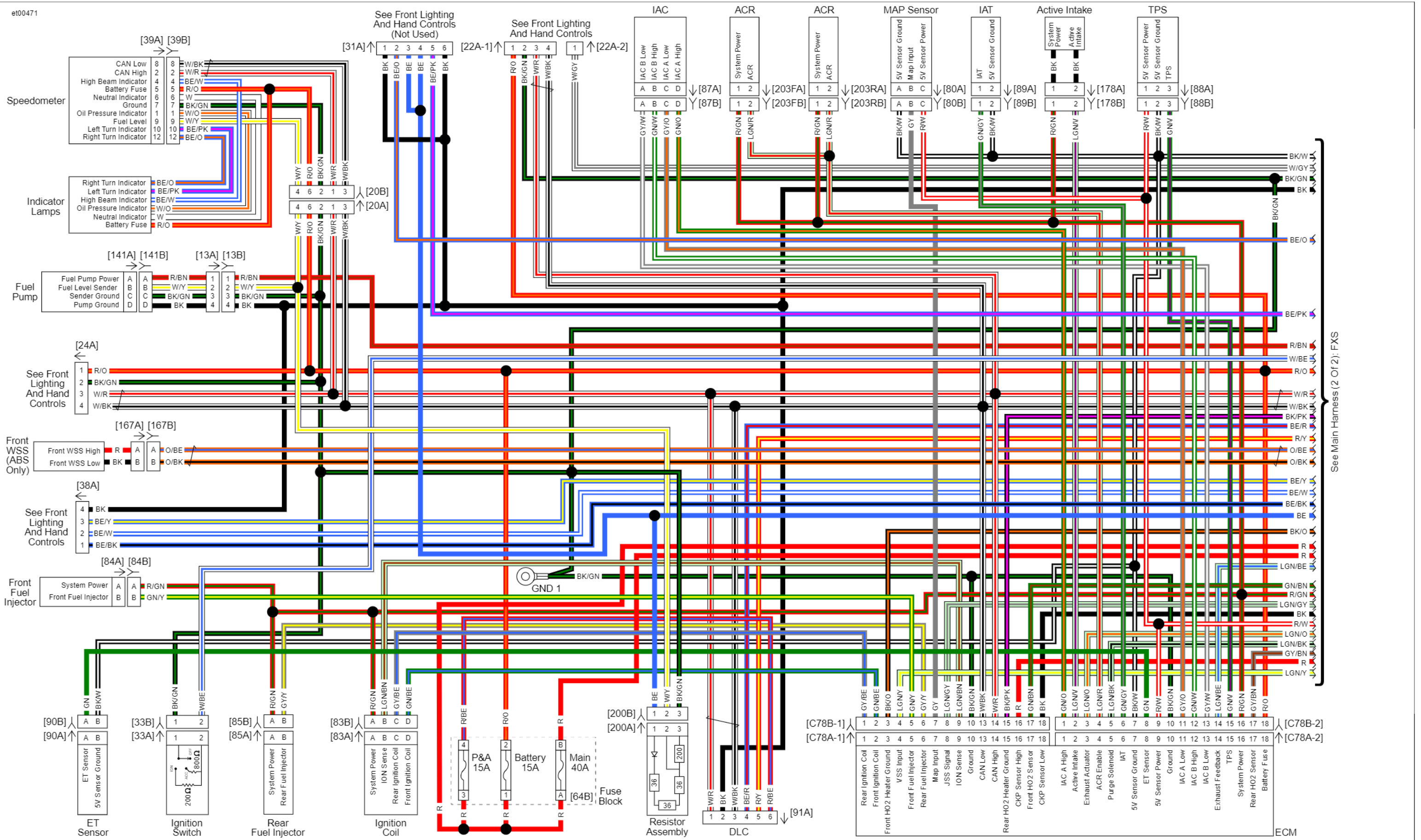

See Main Harness (2 Of 2): FXS

Main Harness 1 of 2: 2012 Softail (FXS)

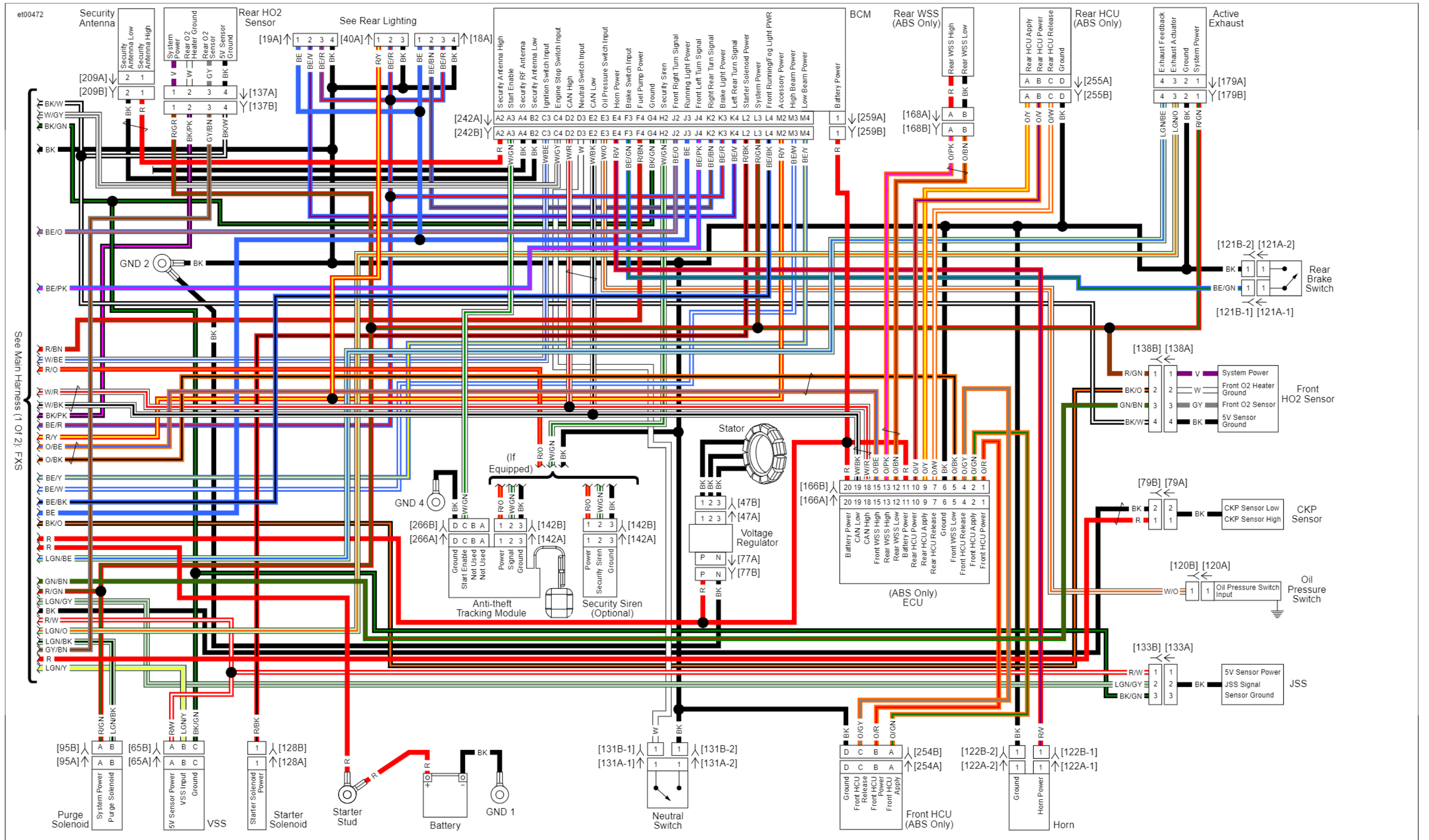

Main Harness 2 of 2: 2012 Softail (FXS)

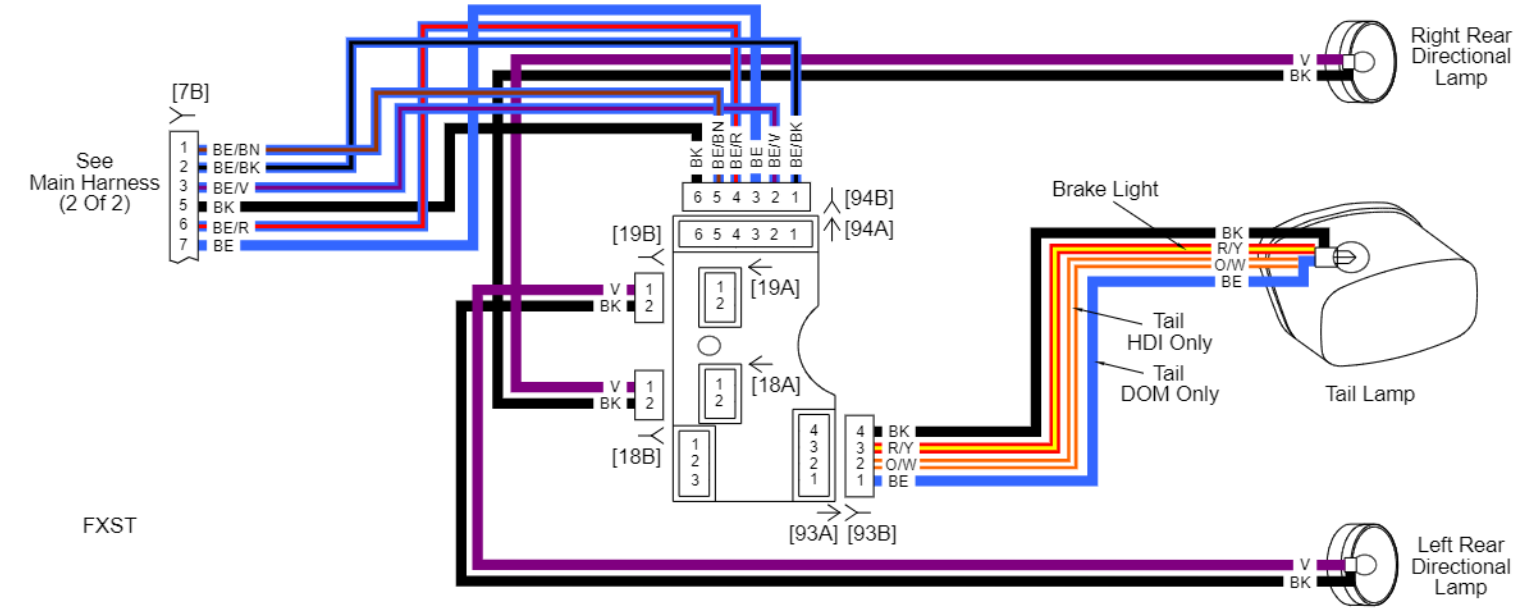
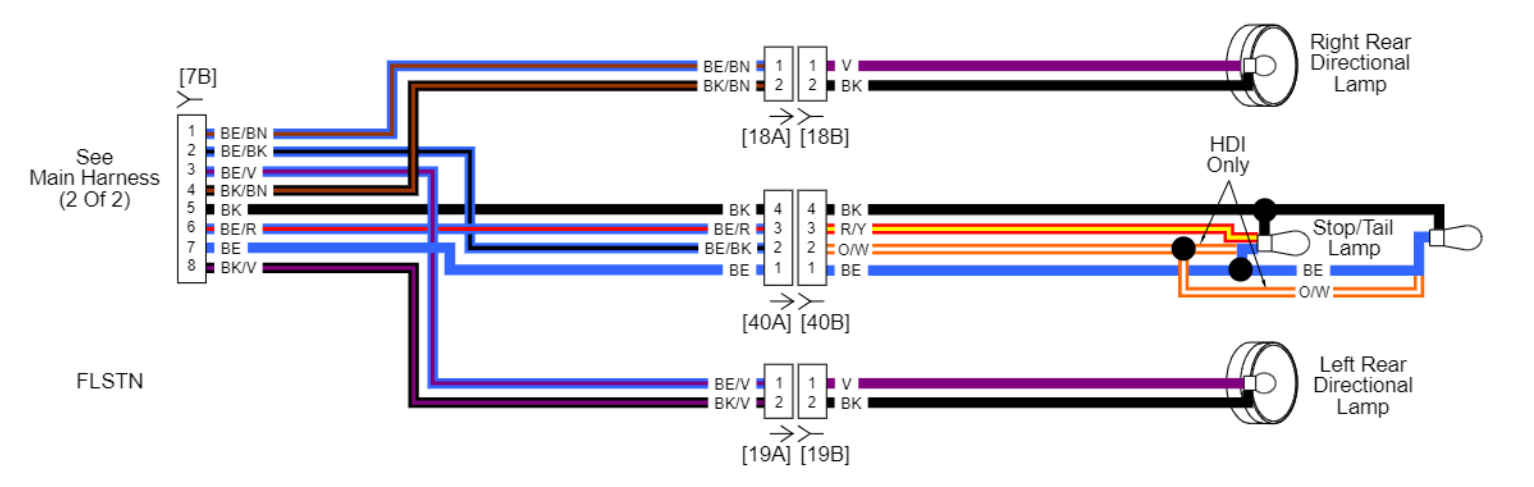
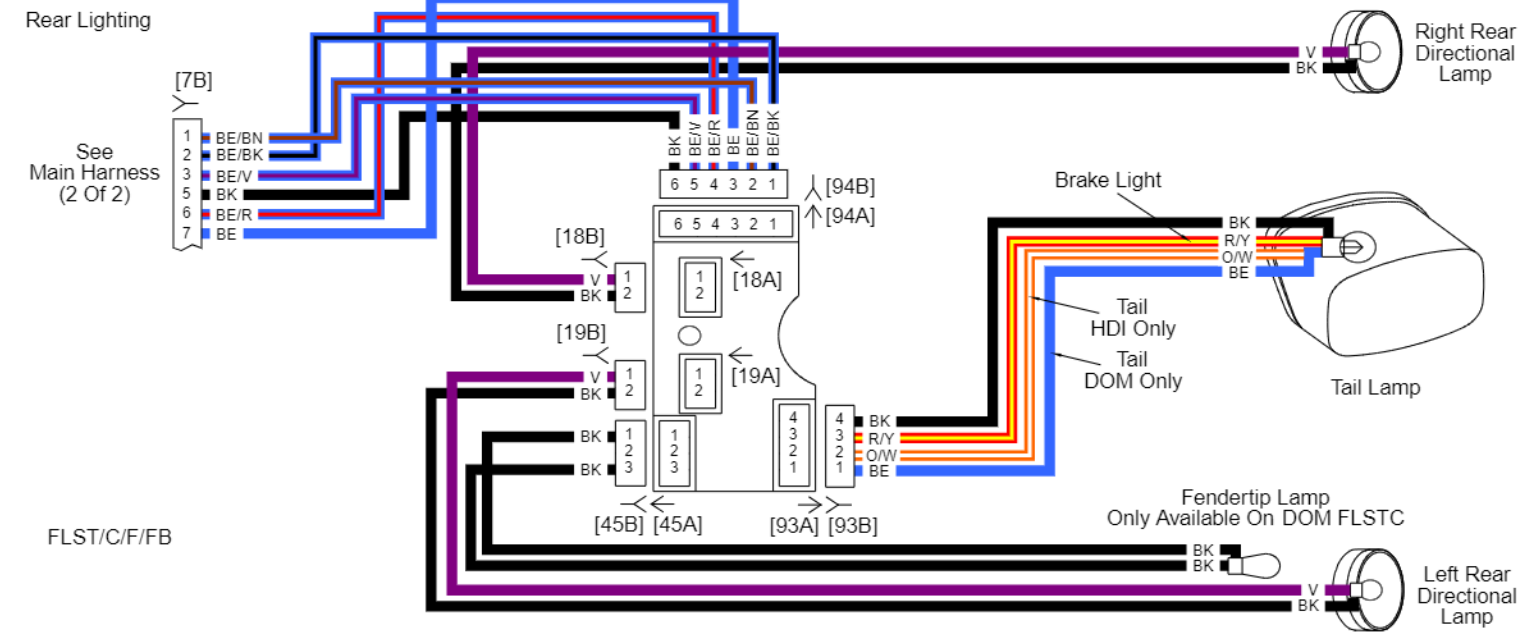
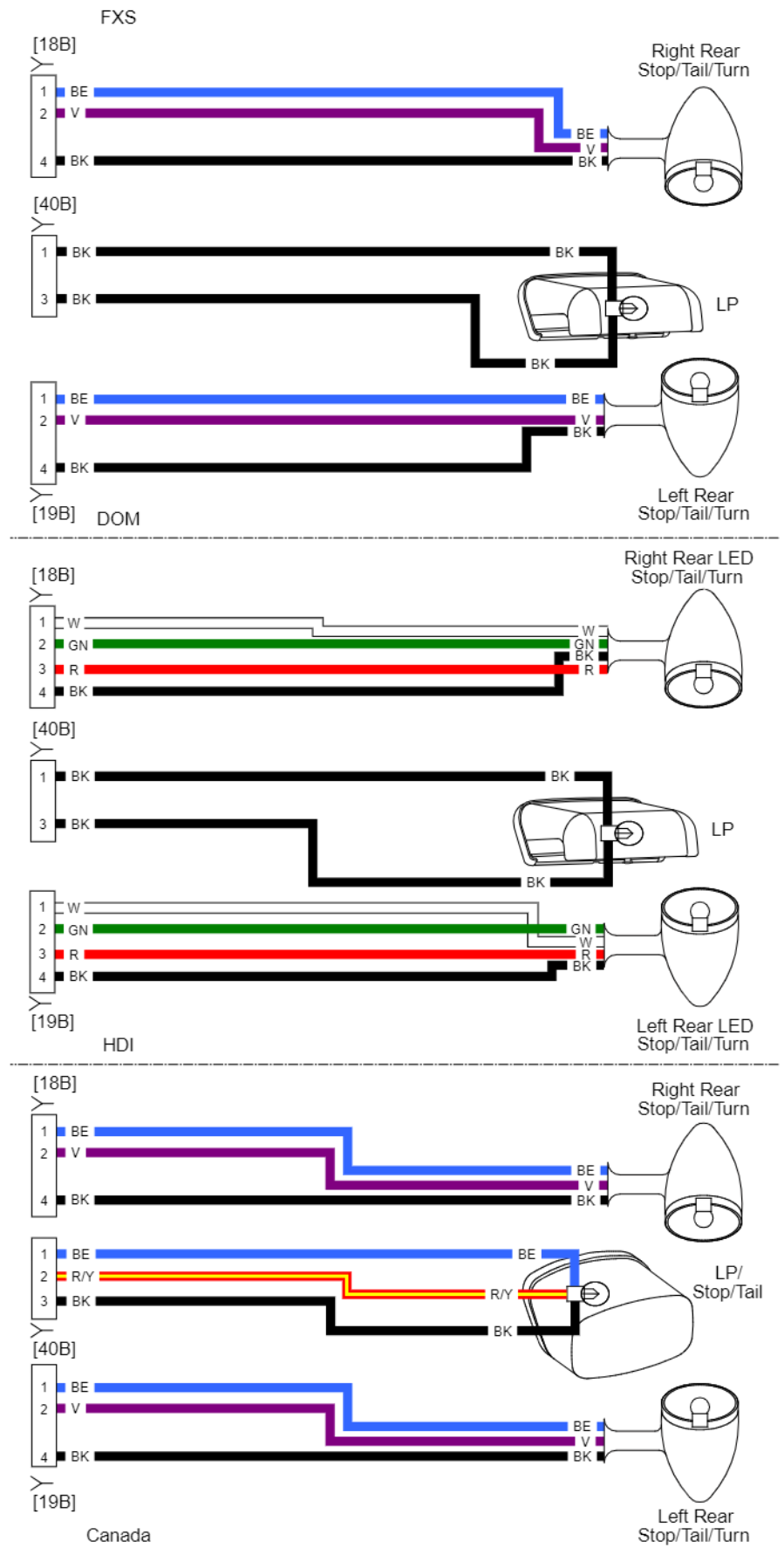

Rear Lighting: 2012 Softail

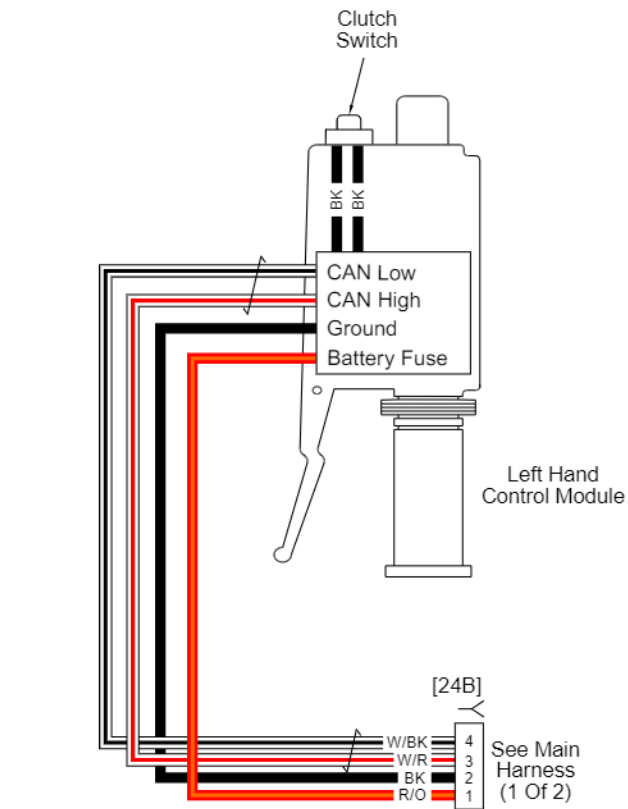
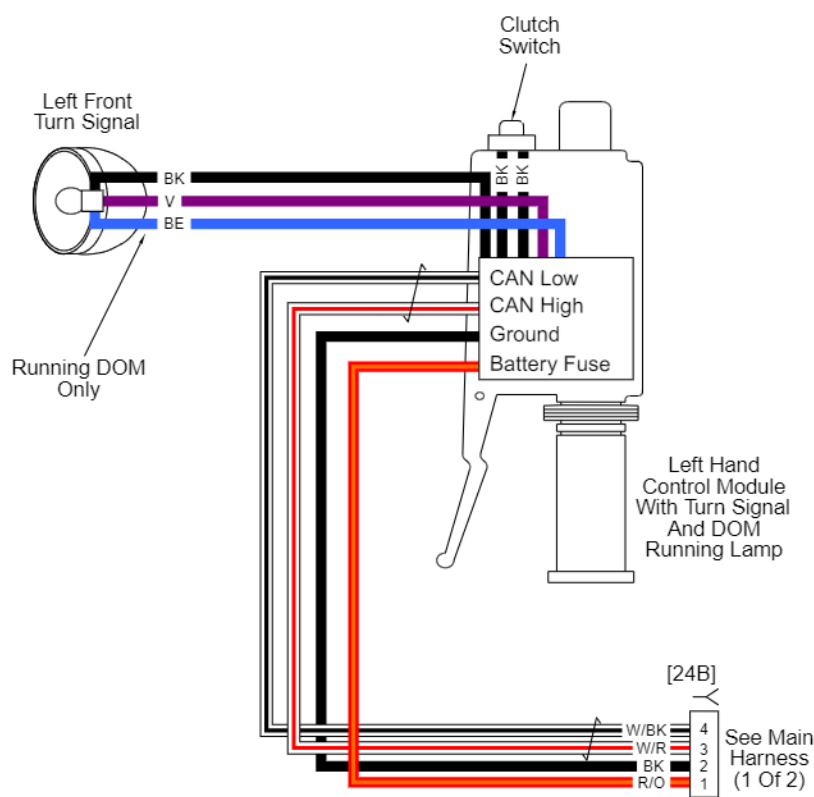
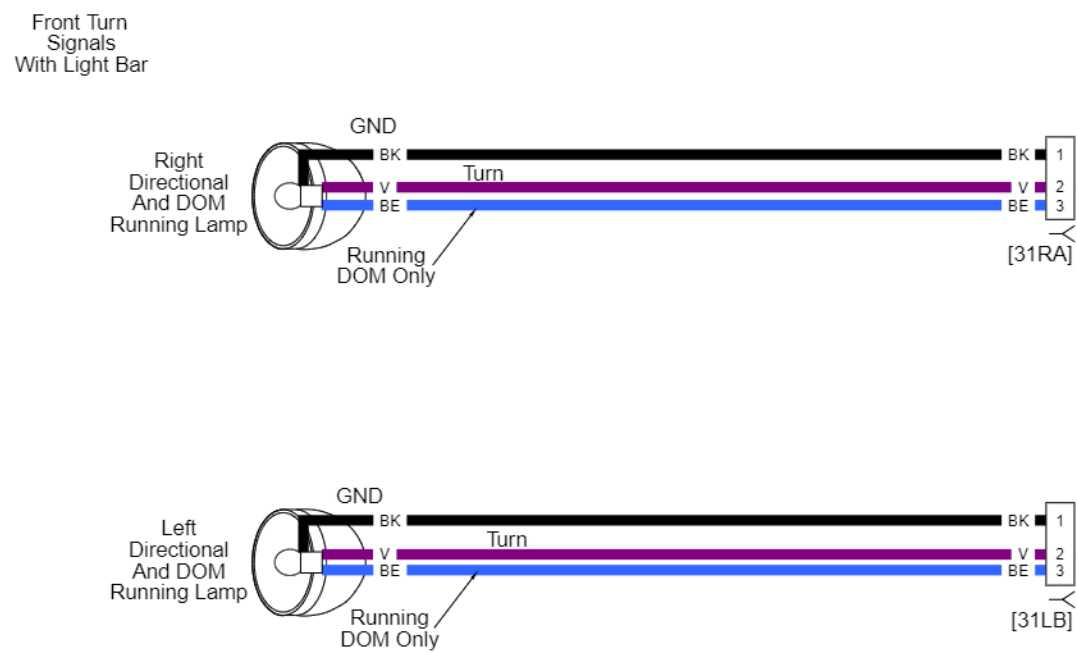
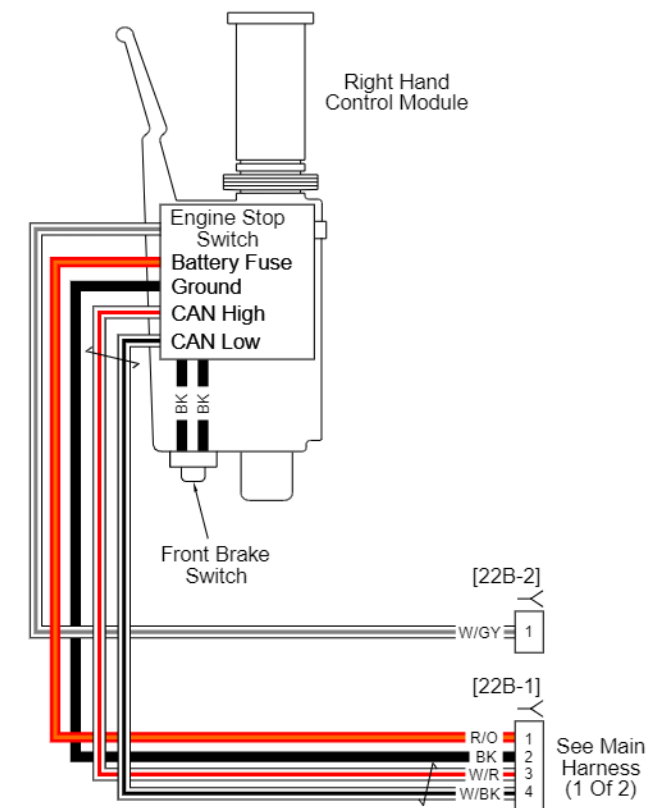
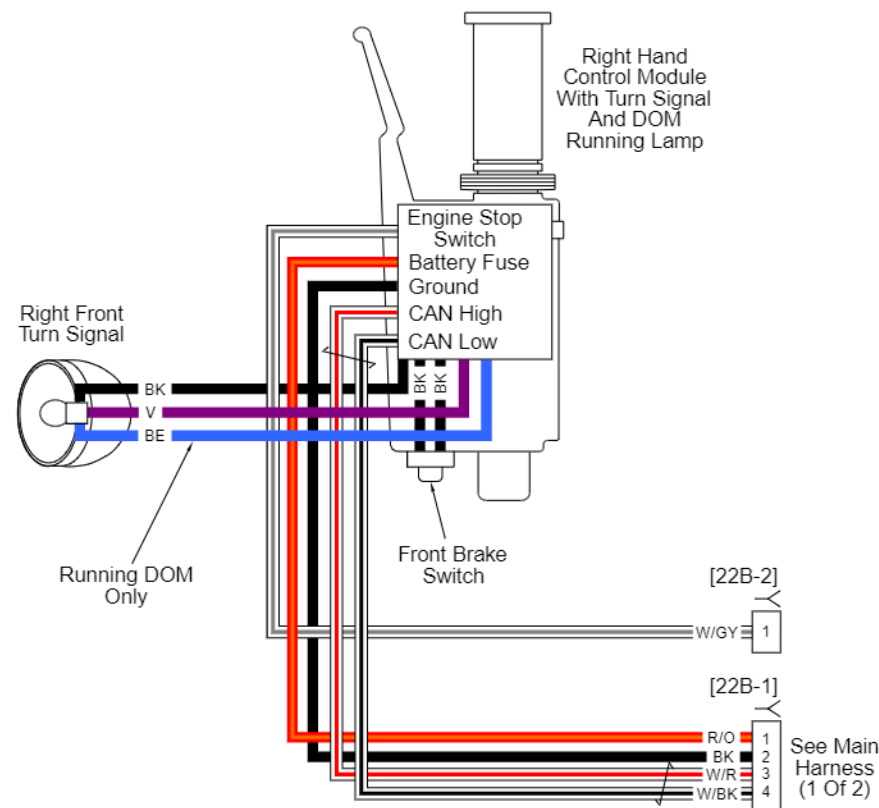
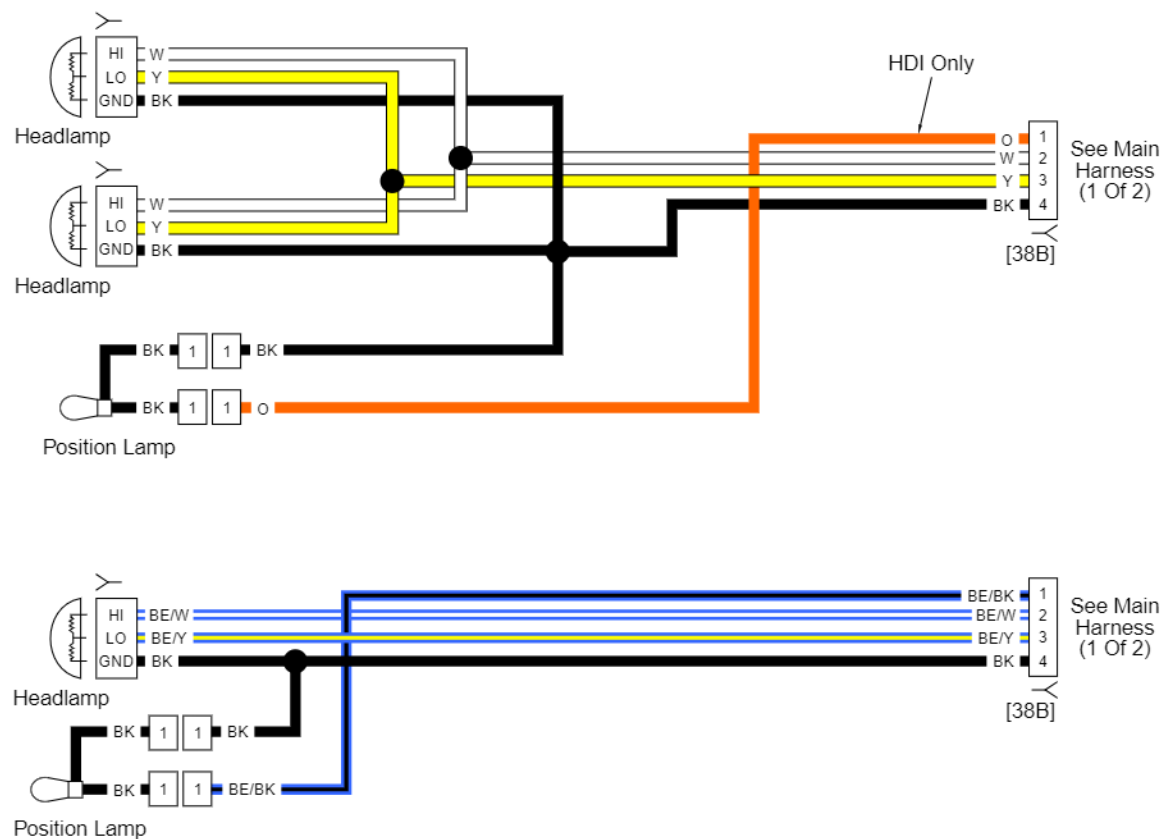

Front Lighting and Hand Controls: 2012 Dyna

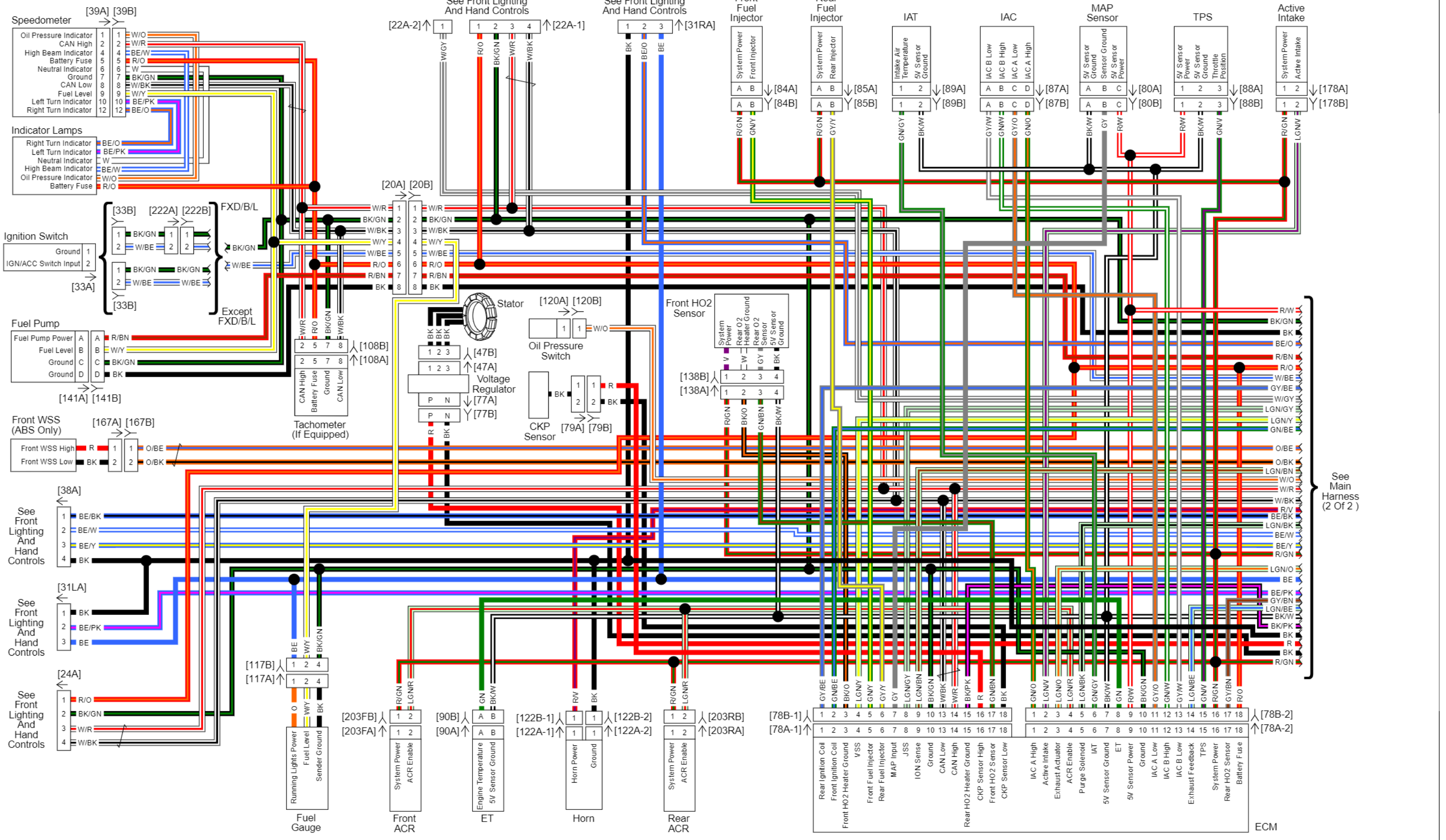

See Main Harness (2 Of 2)

Main Harness 1 of 2: 2012 Dyna

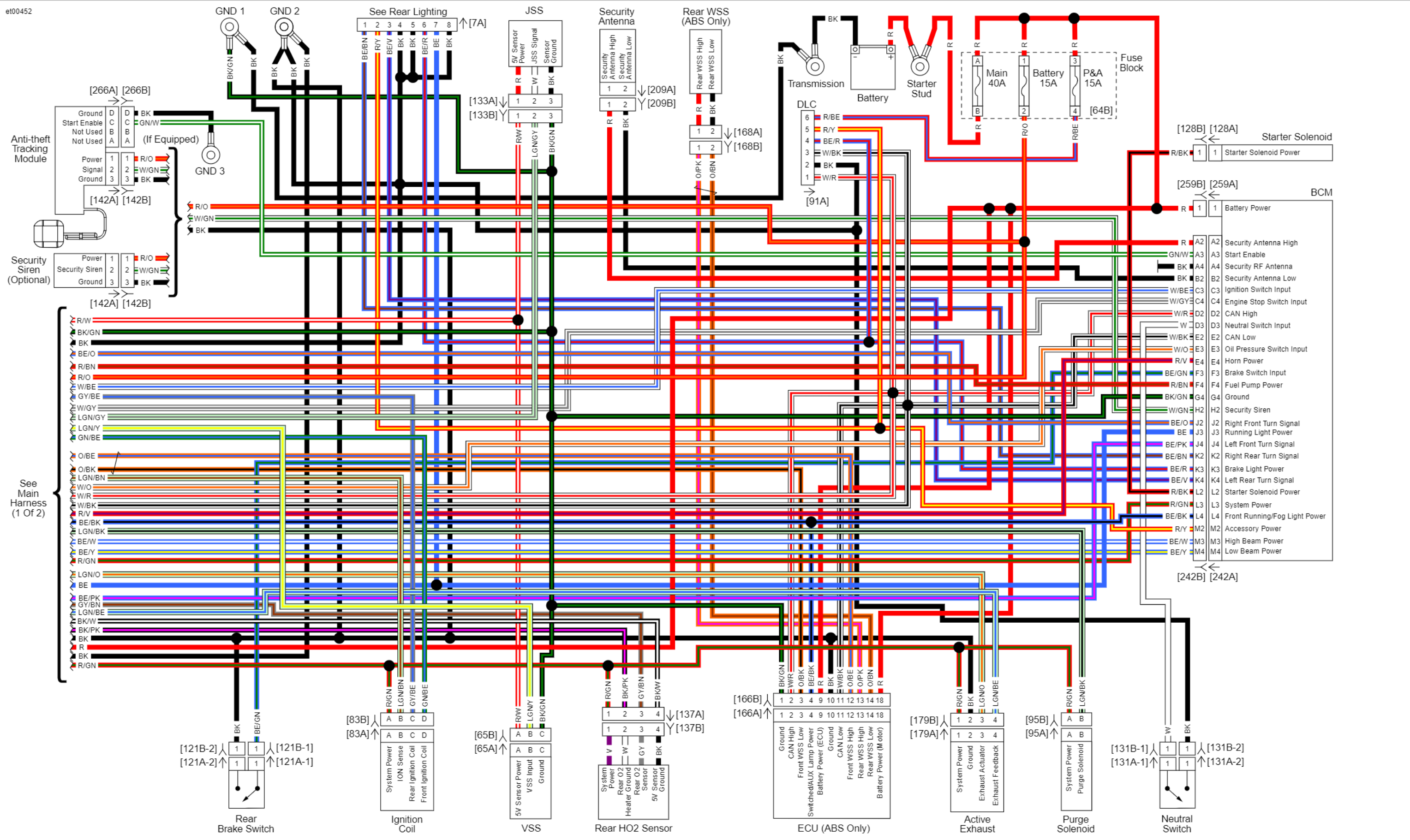

Main Harness 2 of 2: 2012 Dyna

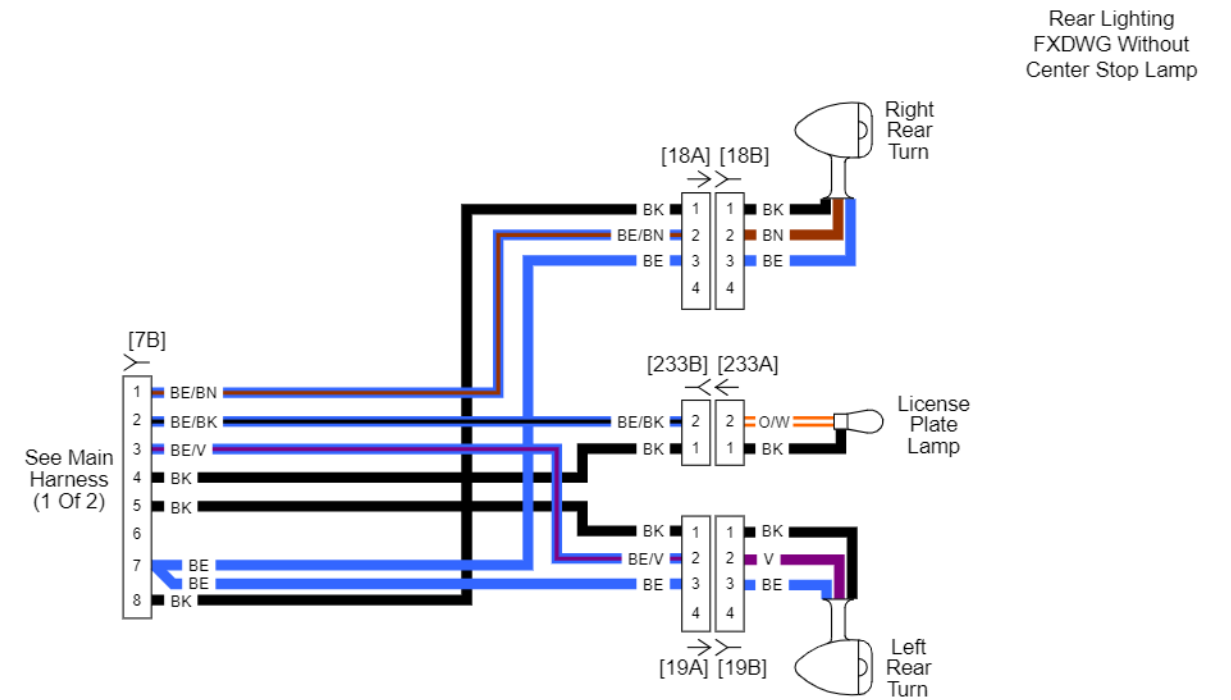
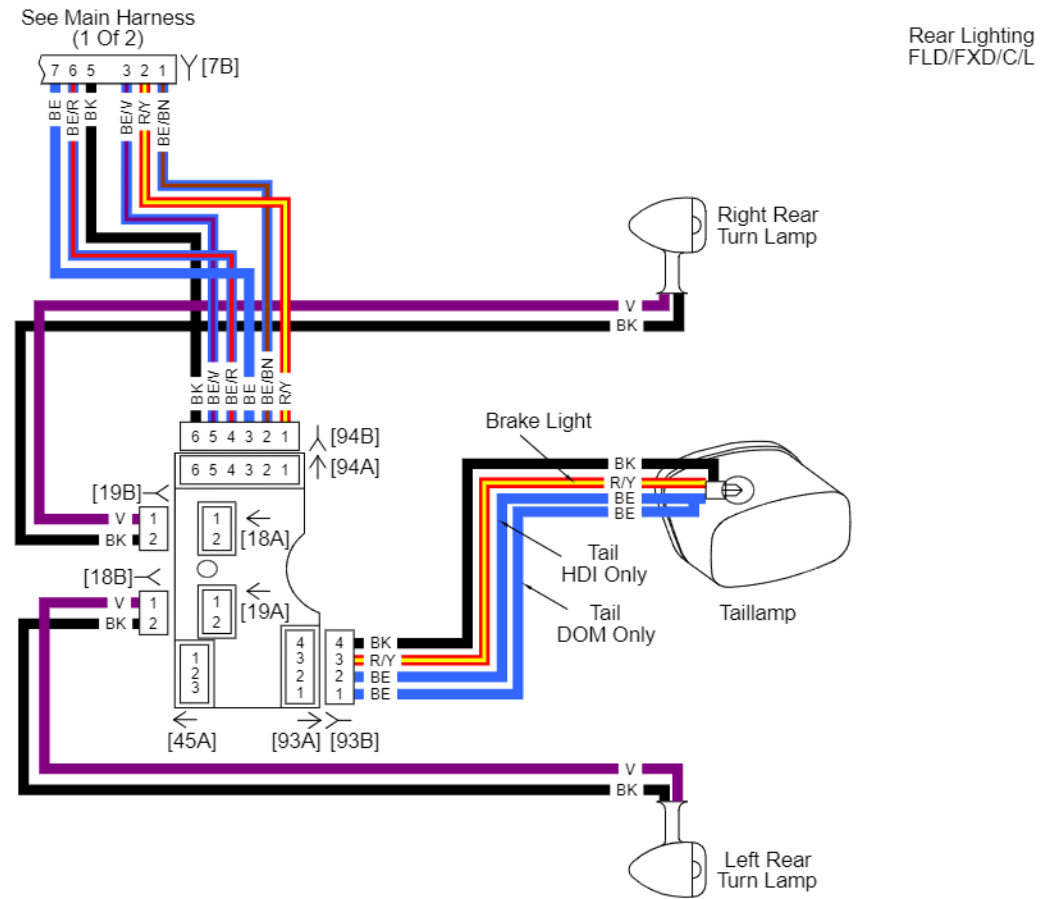
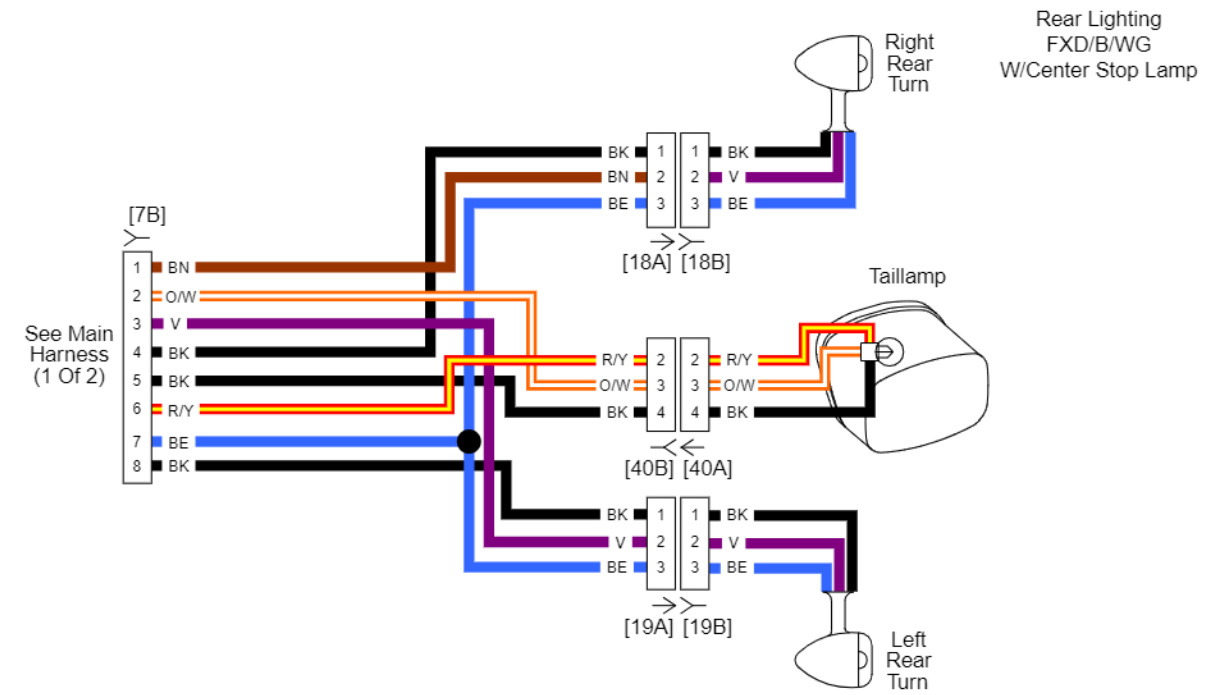
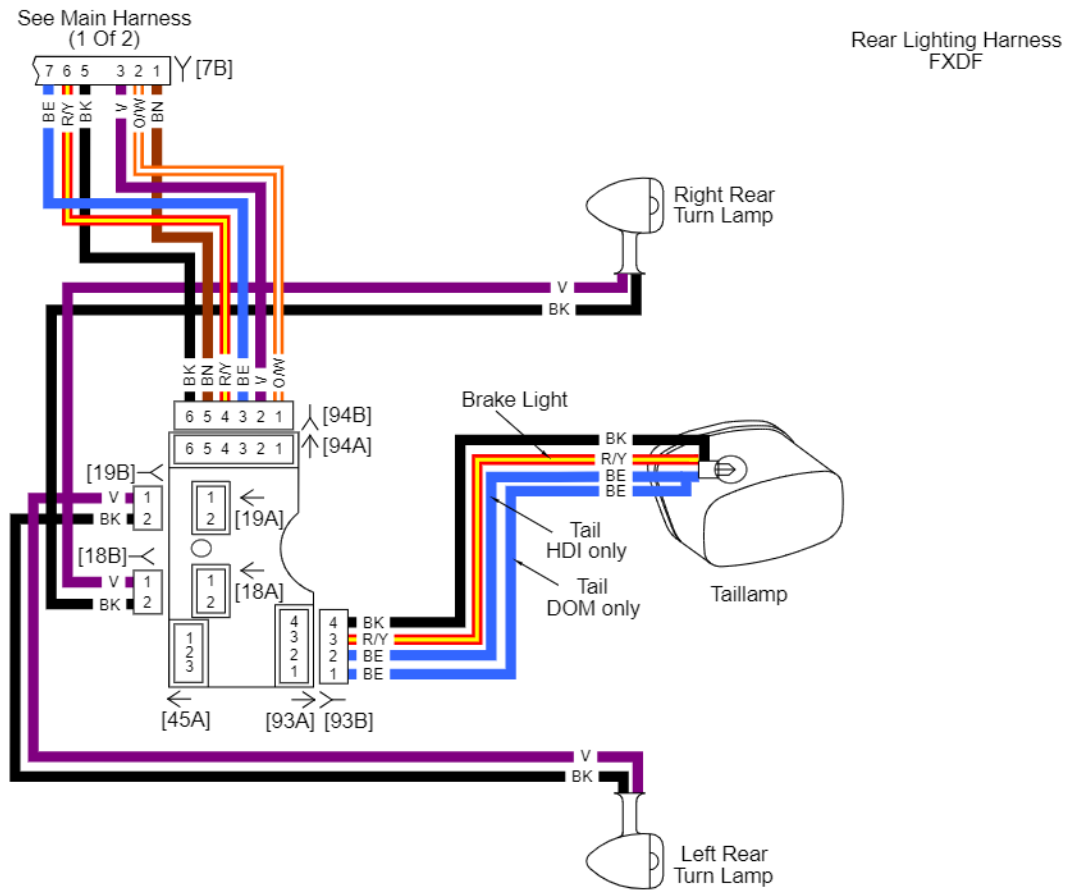

Rear Lighting: 2012 Dyna

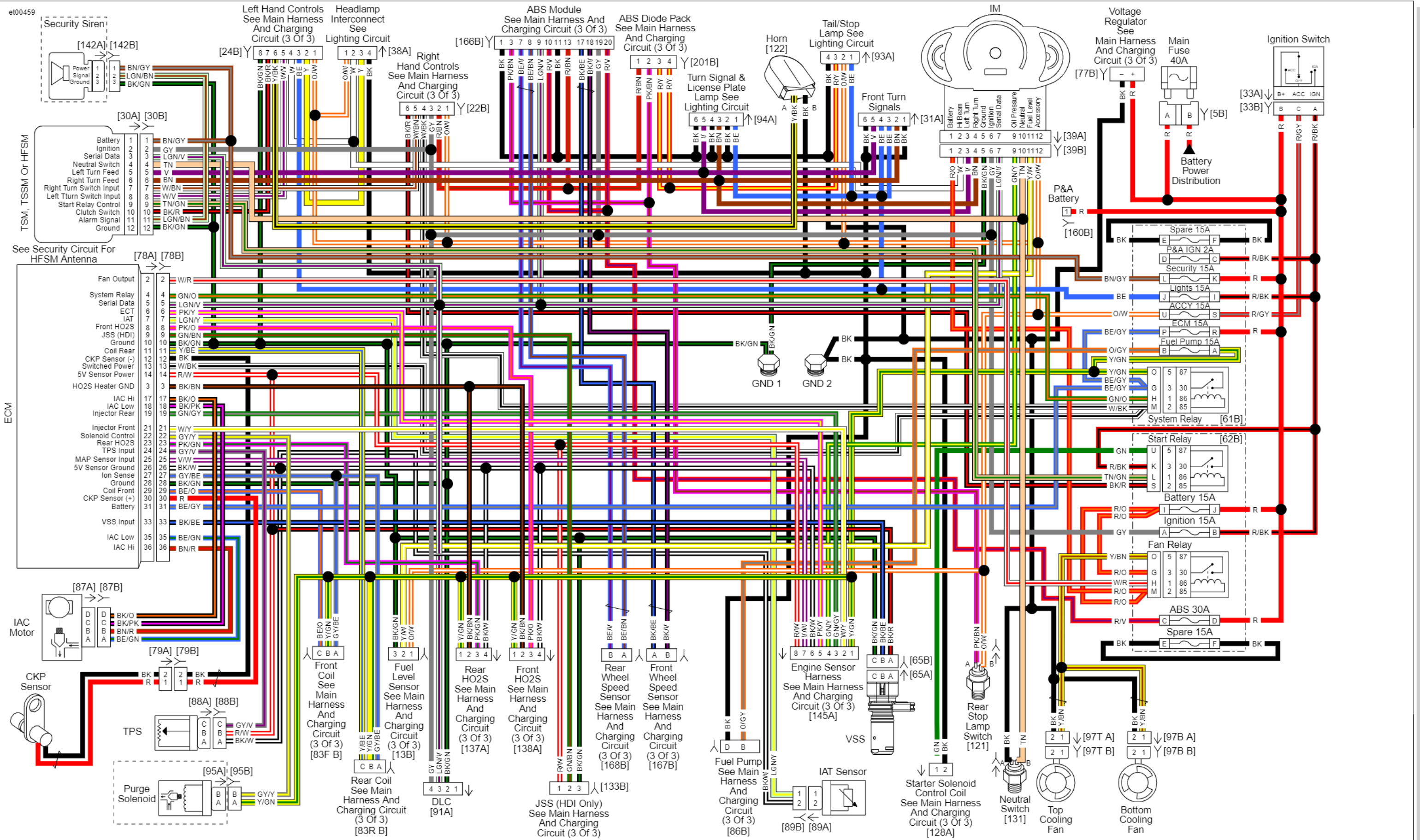

Main Harness (1 of 3): 2012 VRSC with ABS

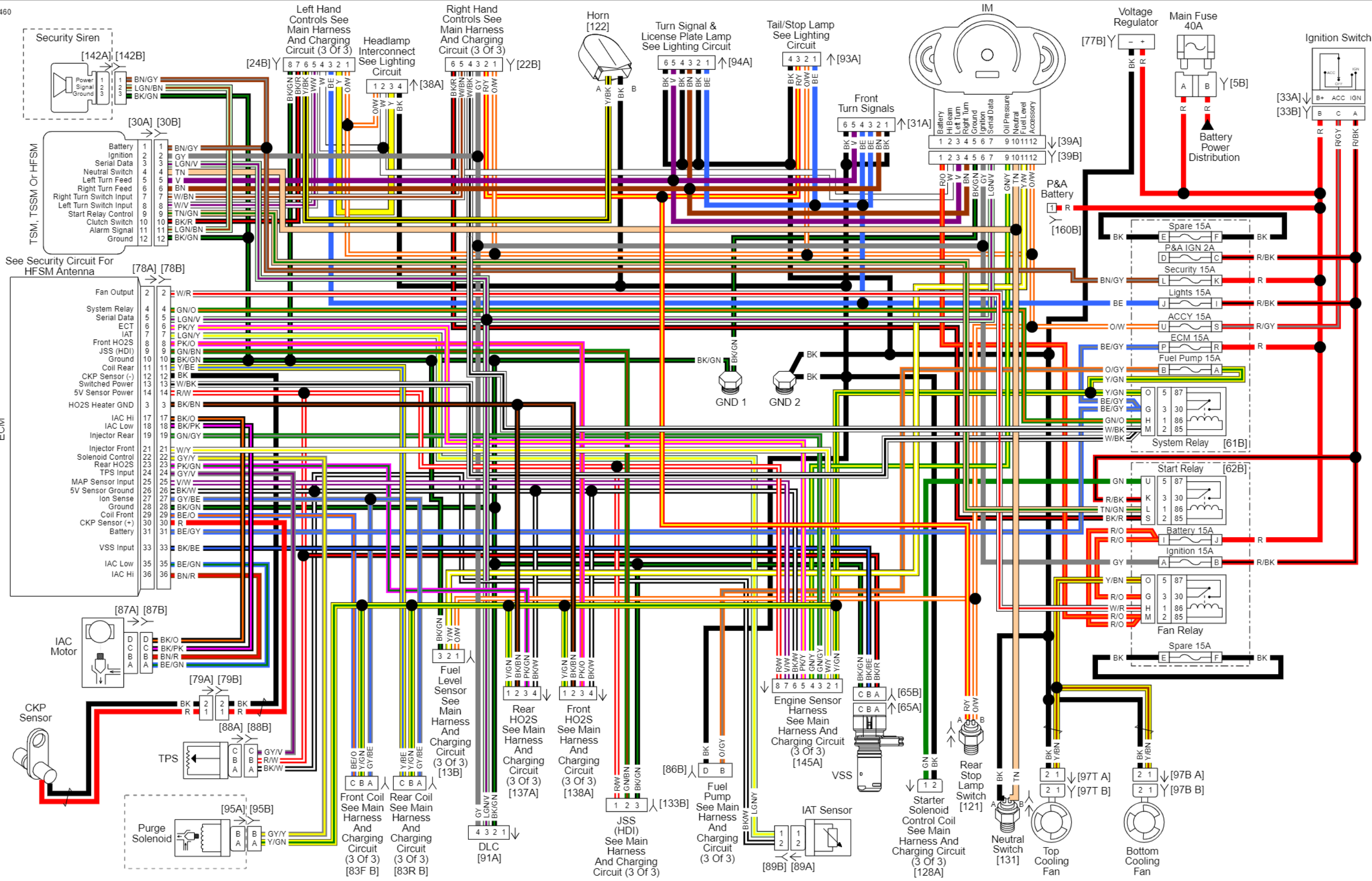

Main Harness (2 of 3): 2012 VRSC without ABS

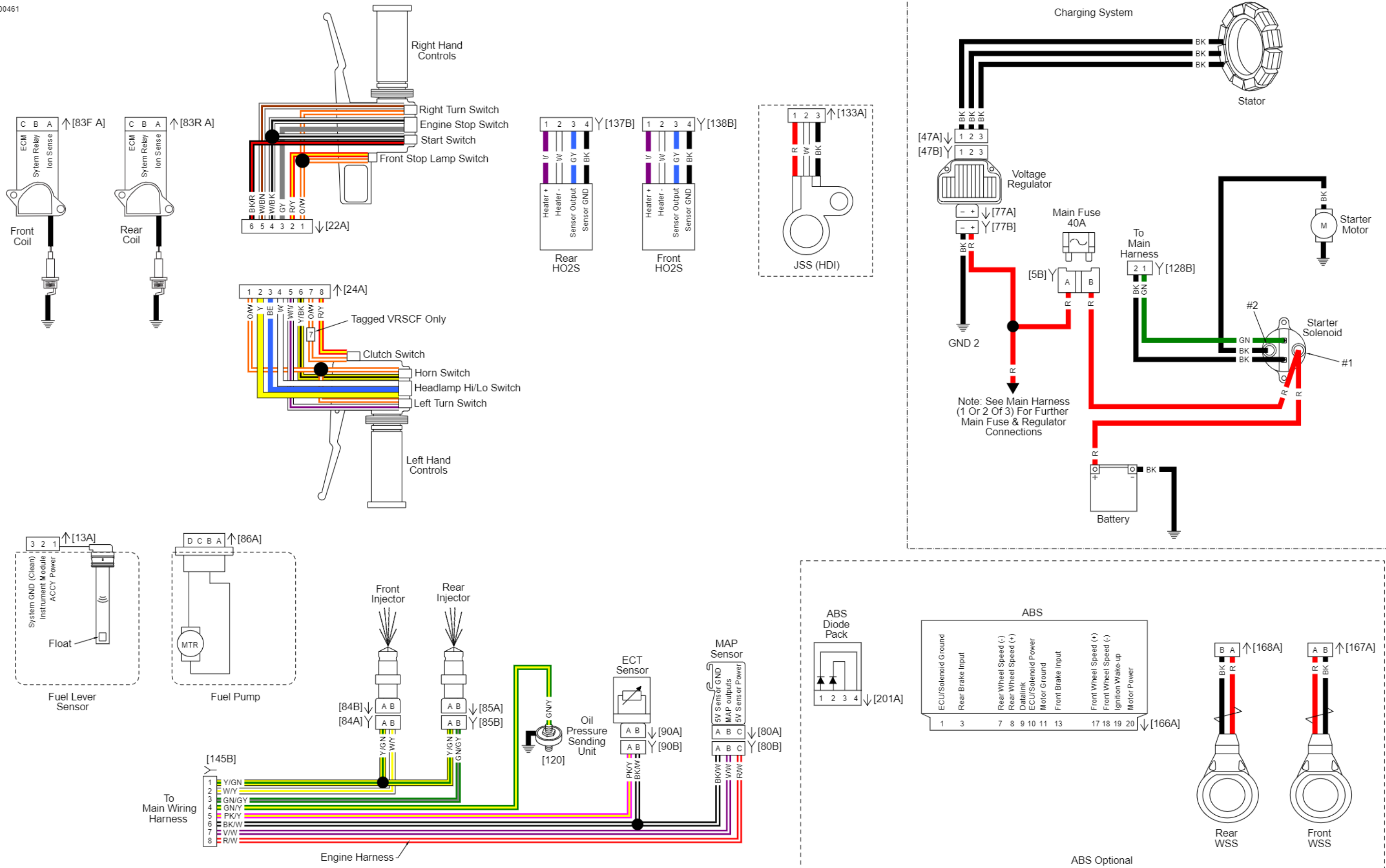

Main Harness and Charging Circuit (3 of 3): 2012 VRSC

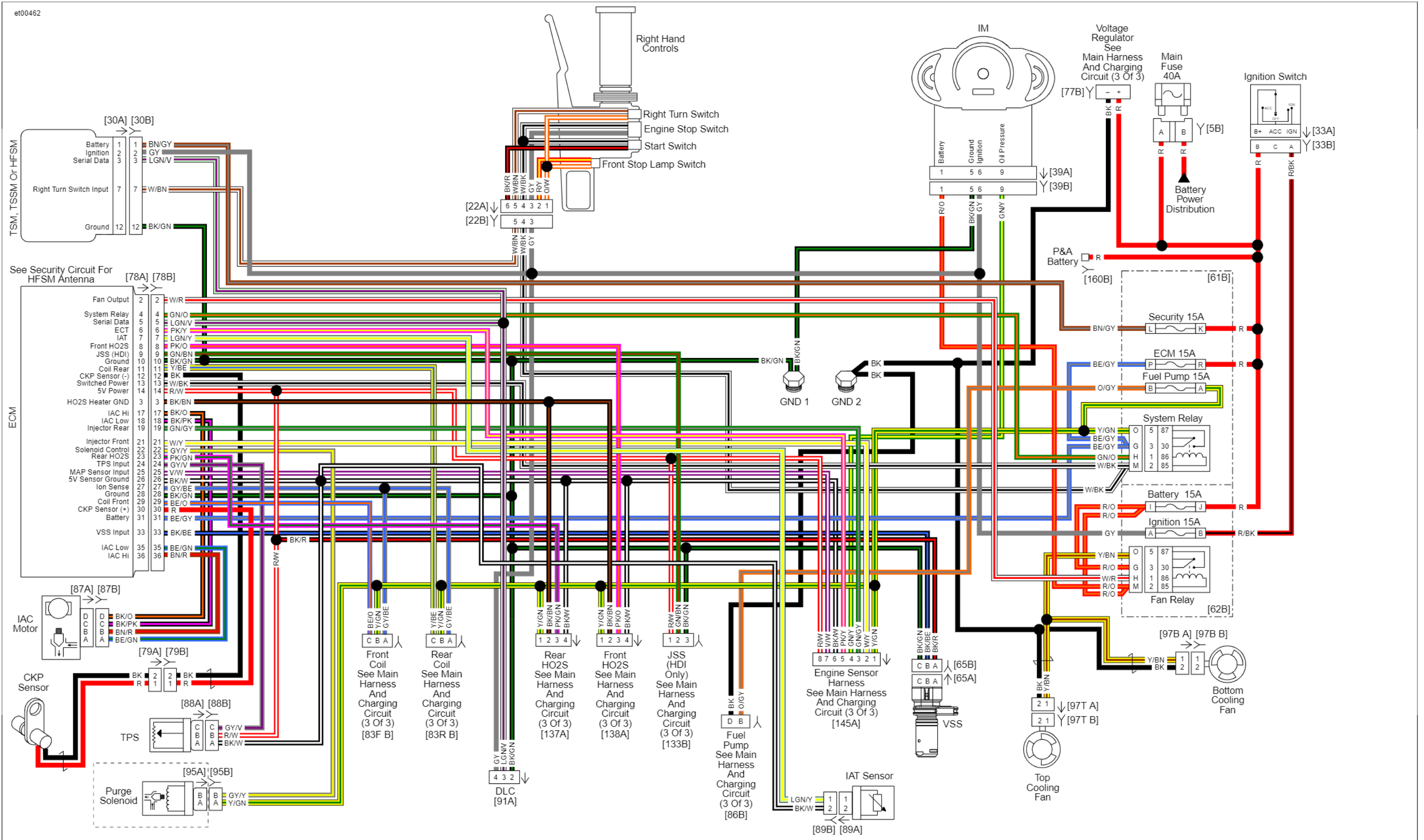

Ignition Circuit: 2012 VRSC

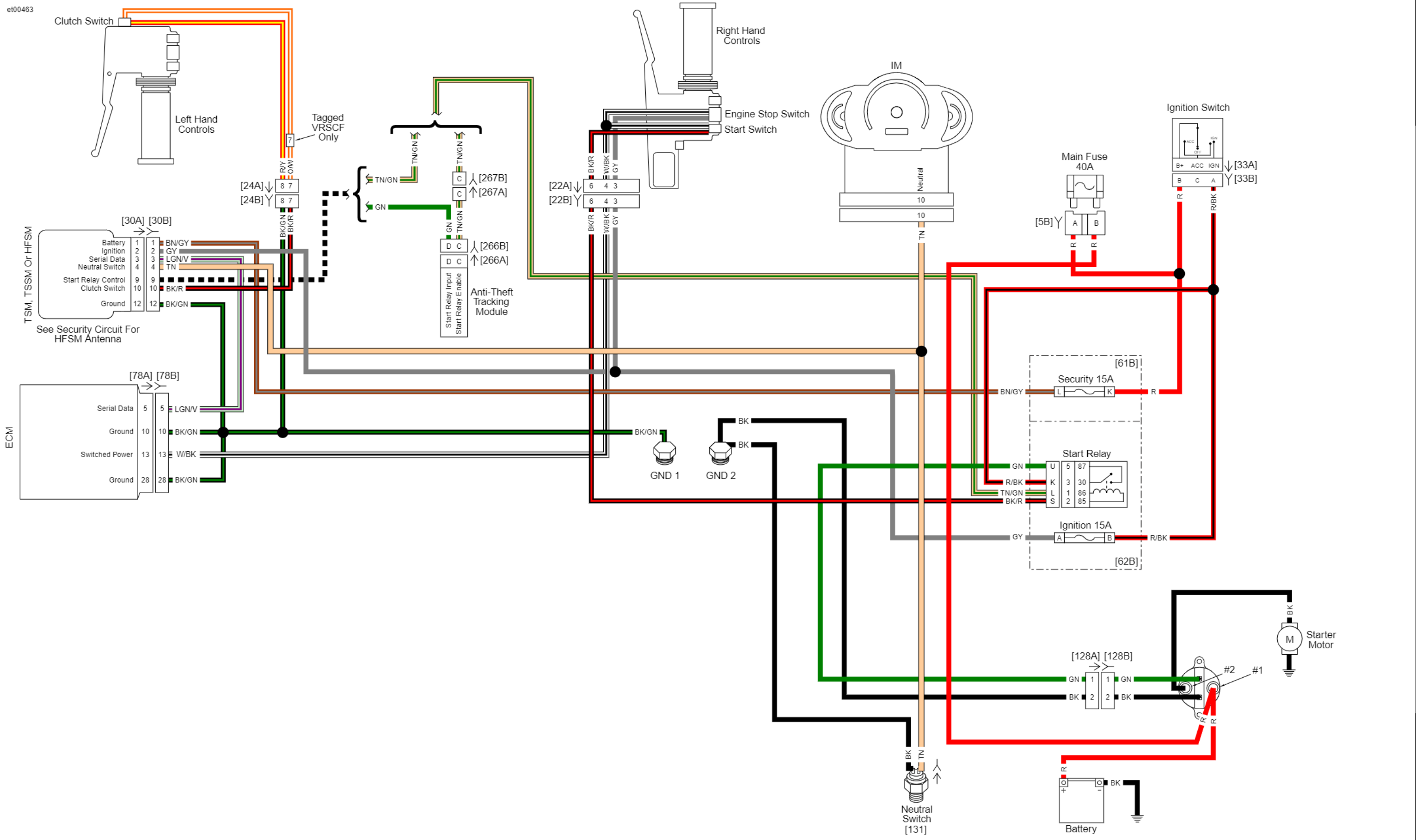

Starting Circuit: 2012 VRSC

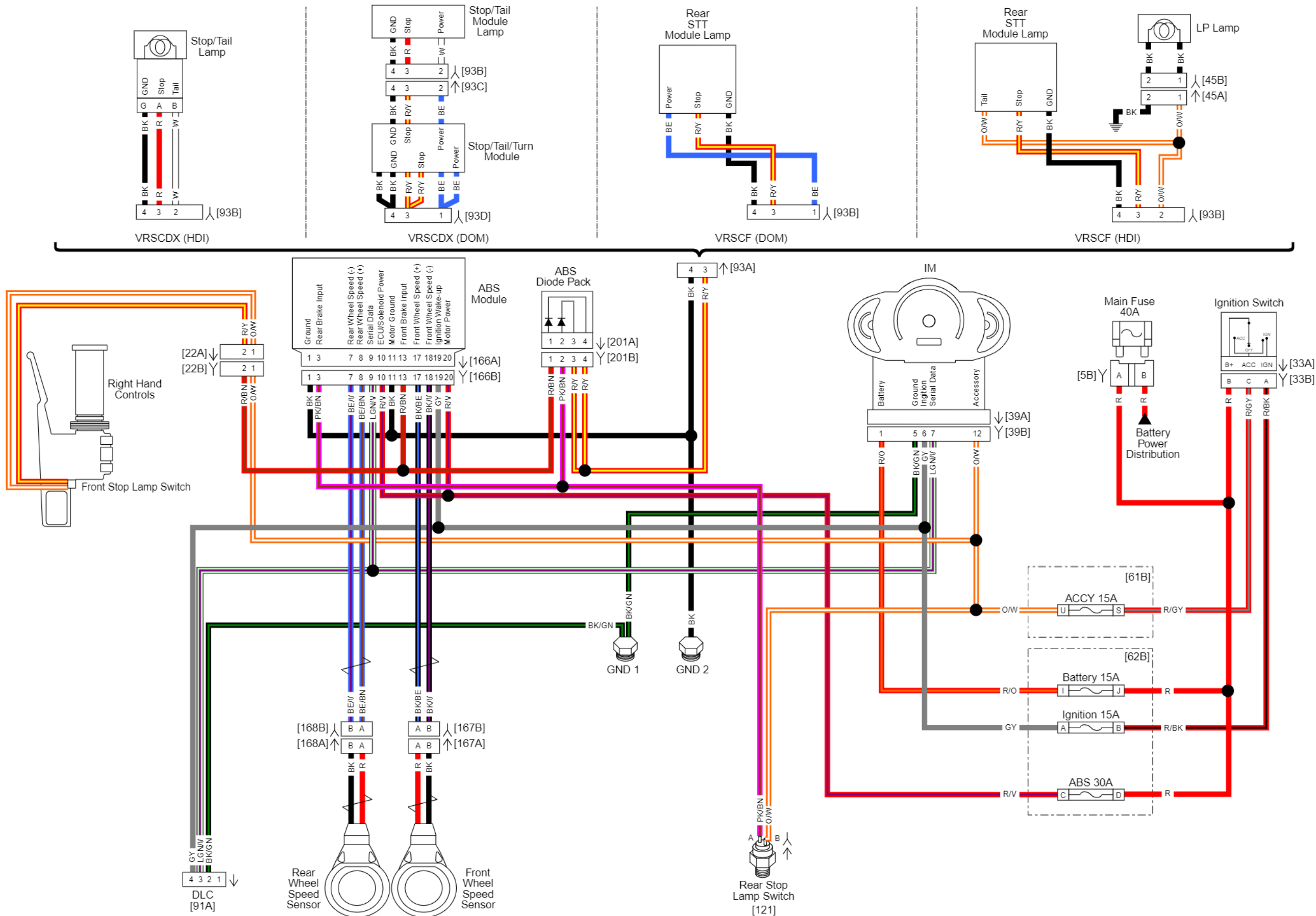

ABS Circuit: 2012 VRSC

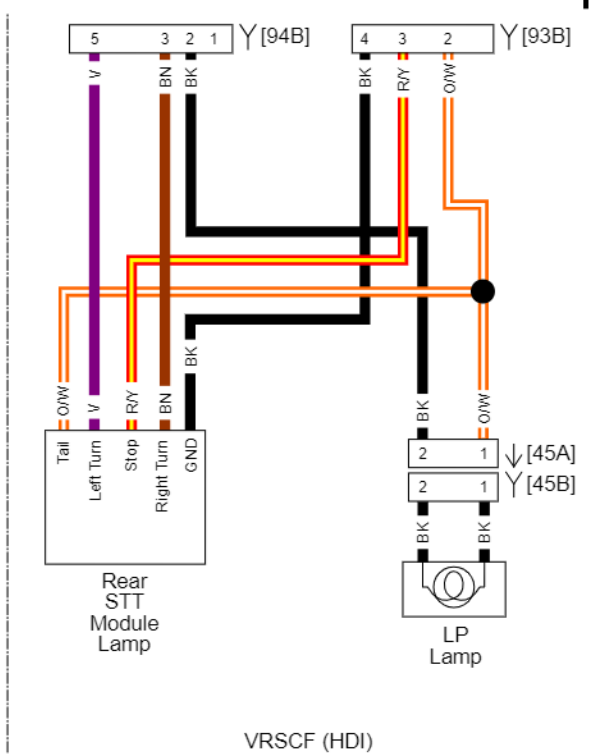
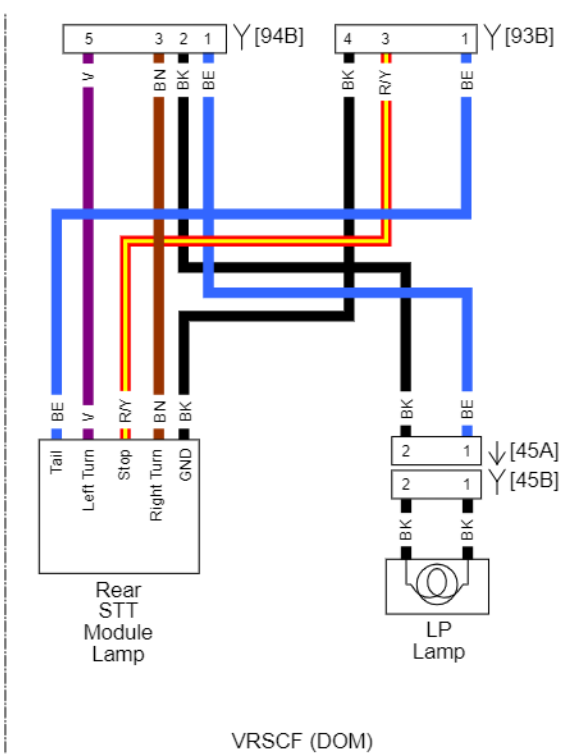
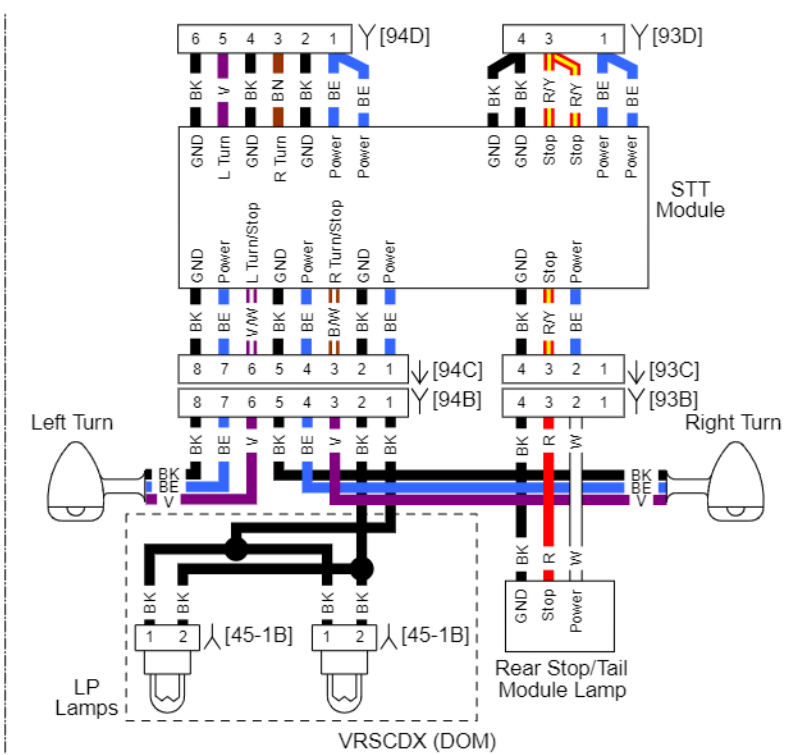
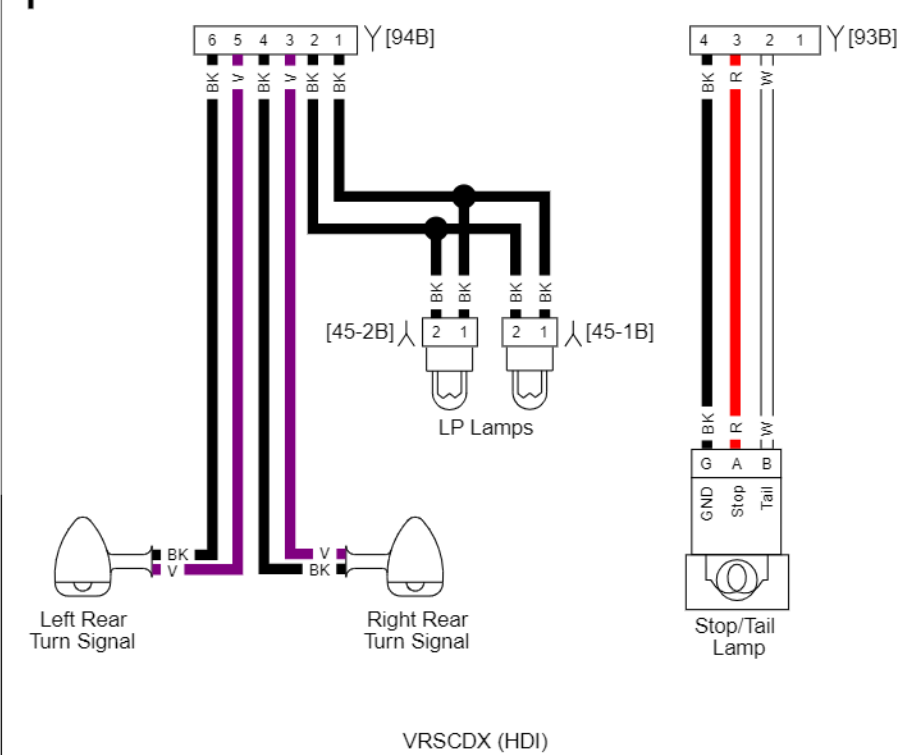
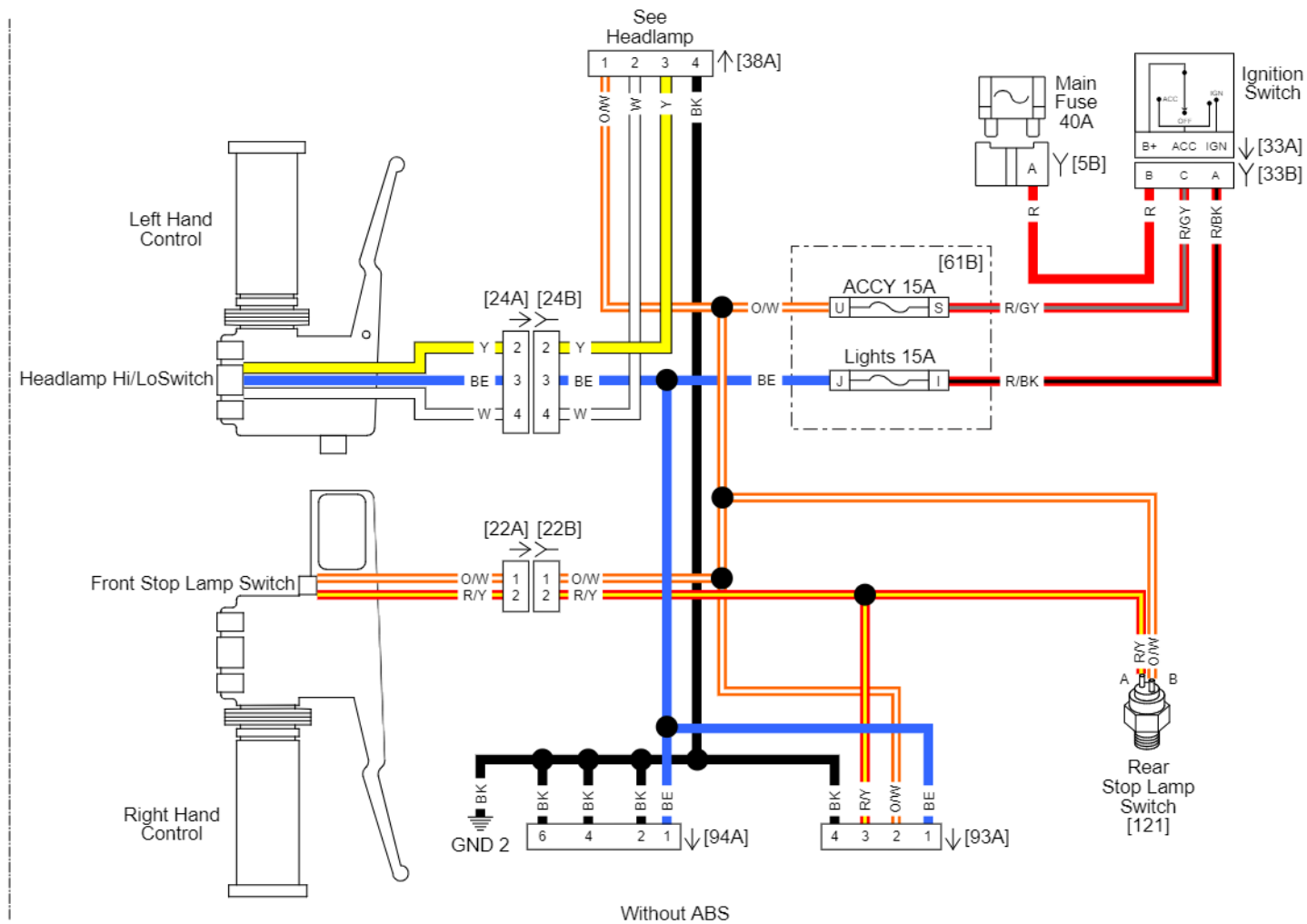
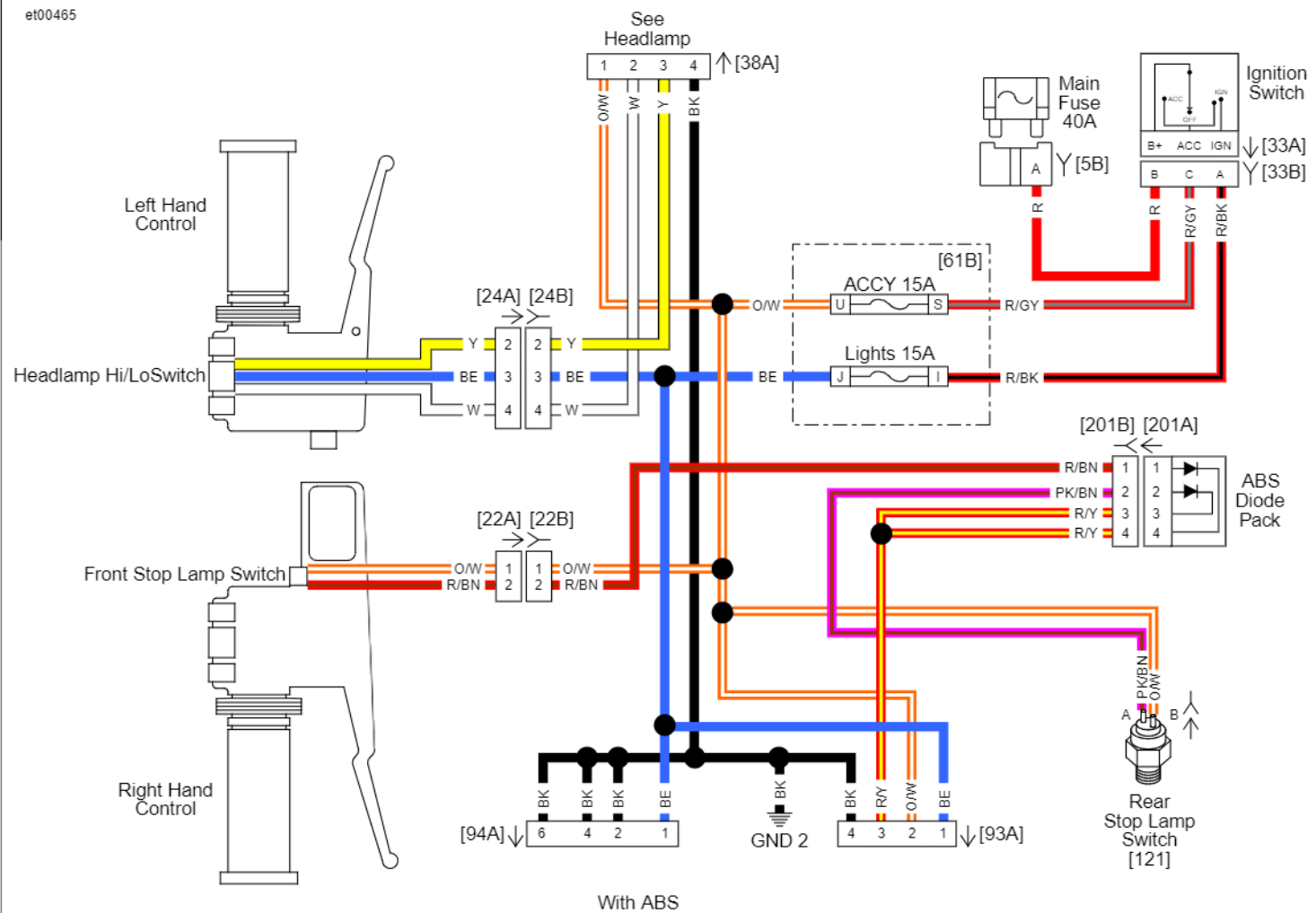

Lighting Circuit: 2012 VRSC

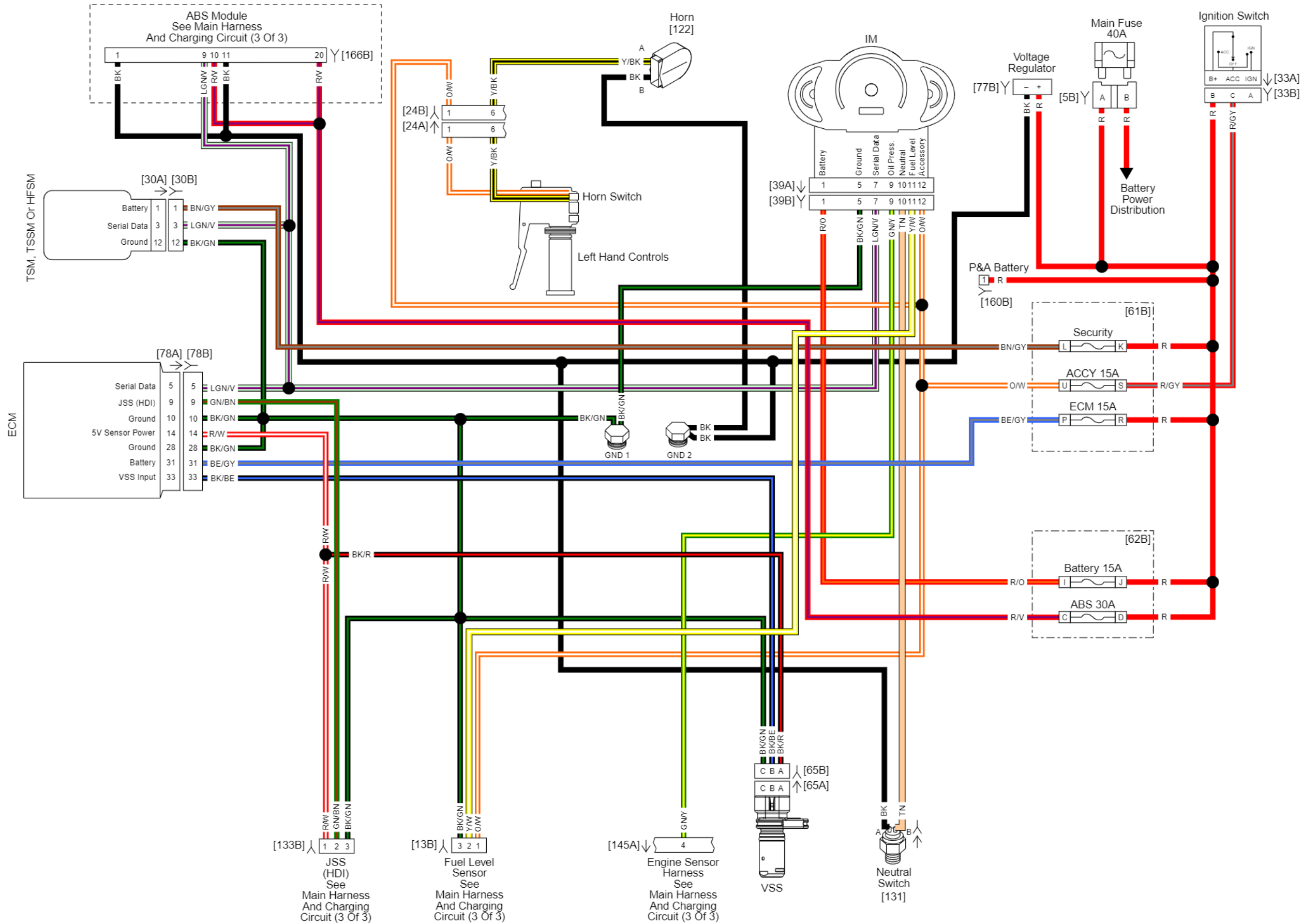

Horn and Instrument Circuit: 2012 VRSC

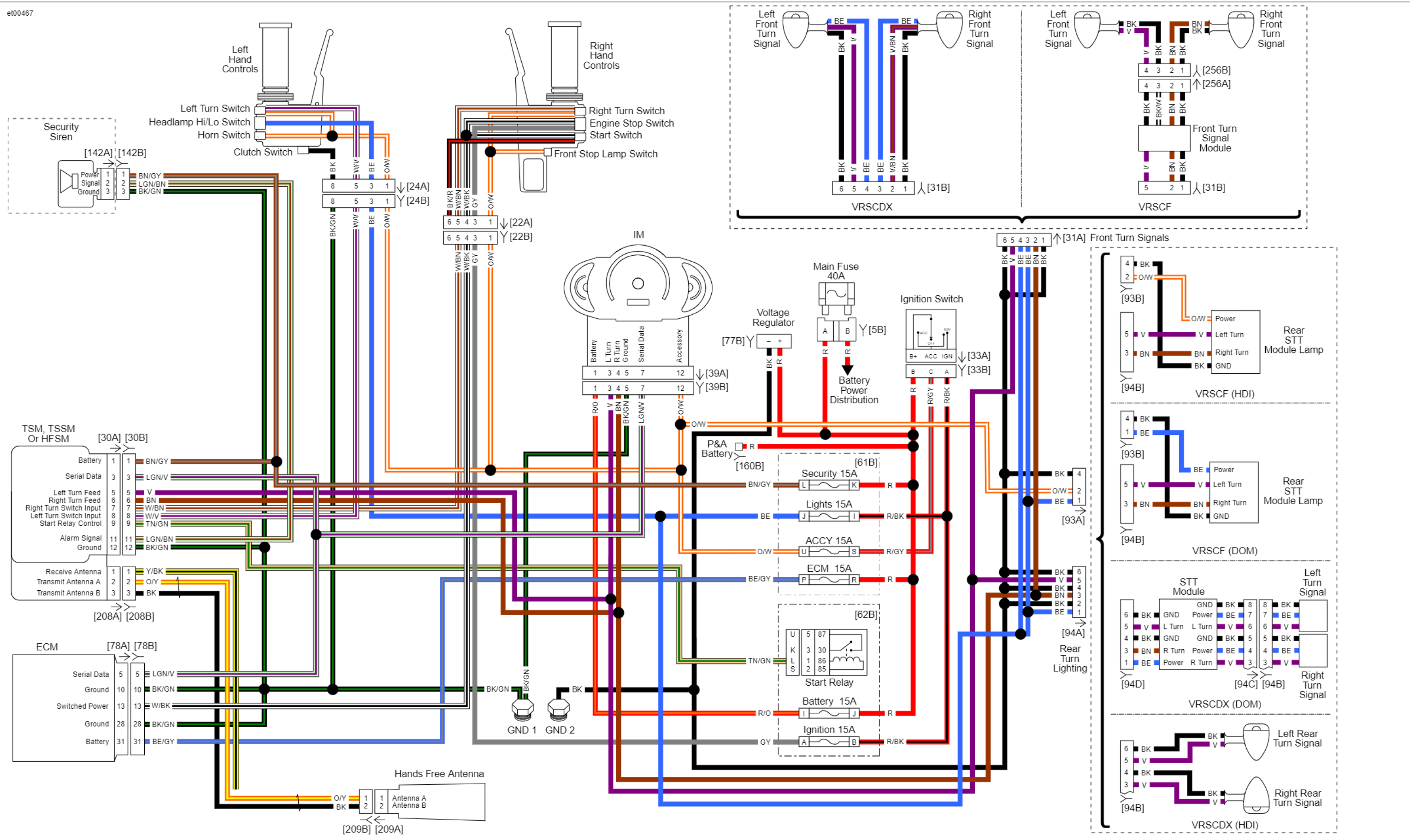

Security Circuit Without Anti-Theft Tracking Module: 2012 VRSC

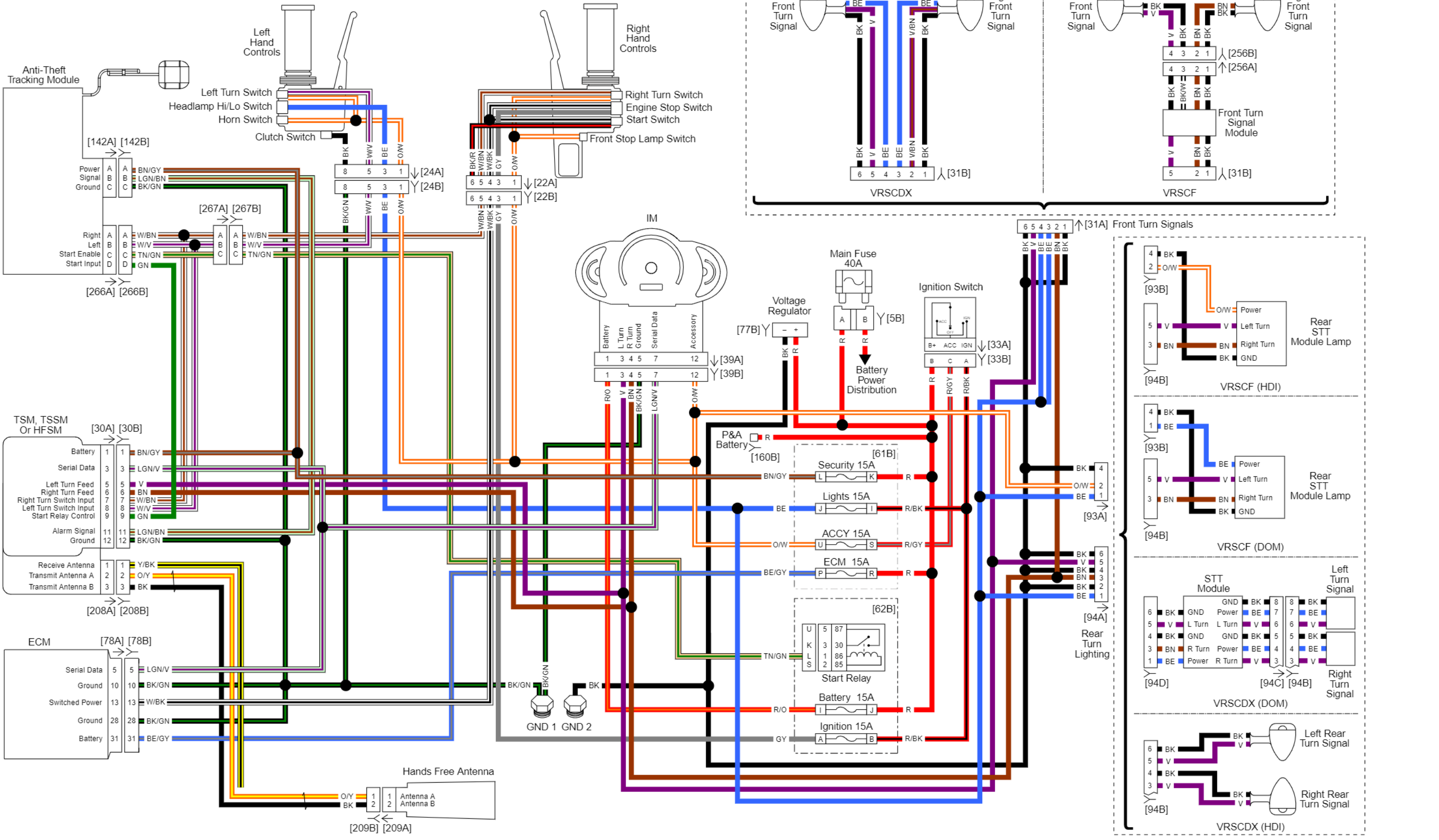

Security Circuit With Anti-Theft Tracking Module: 2012 VRSC

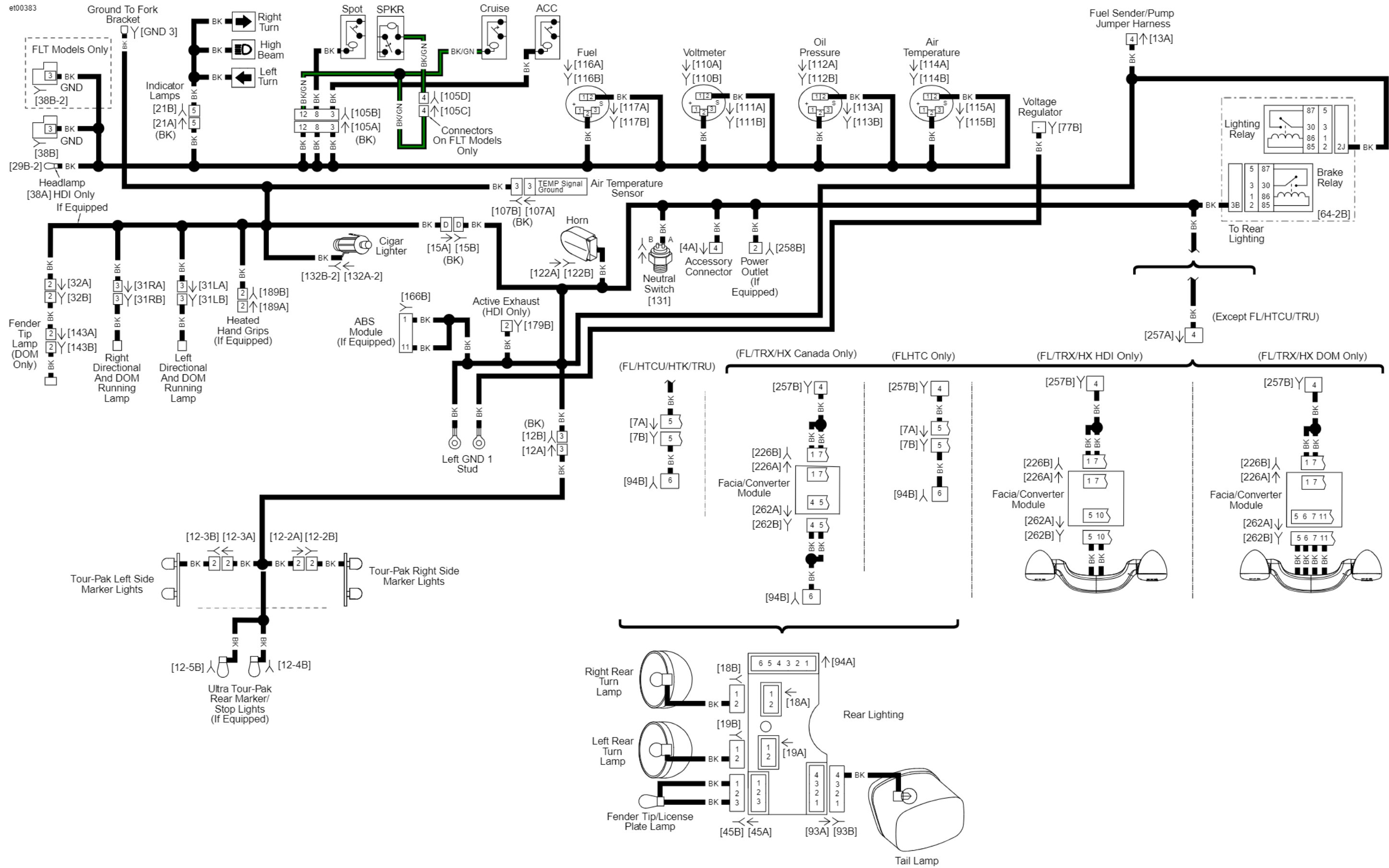

Left GND1: 2012 Touring (Except FLHR/C)

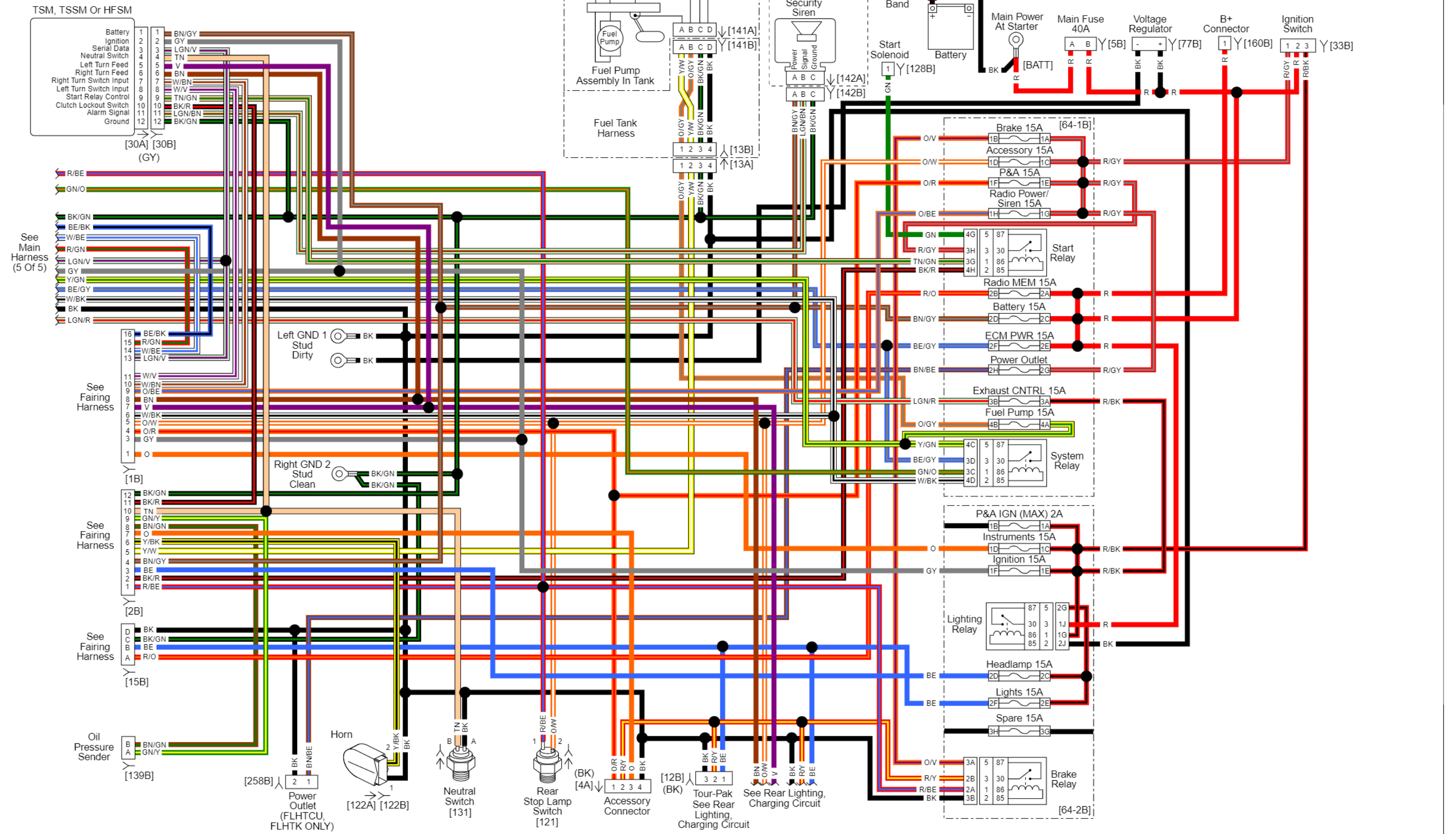

Main Harness (1 OF 5): 2012 Touring (Except FLHR/C) without ABS

TSM, TSSM Or HFSM

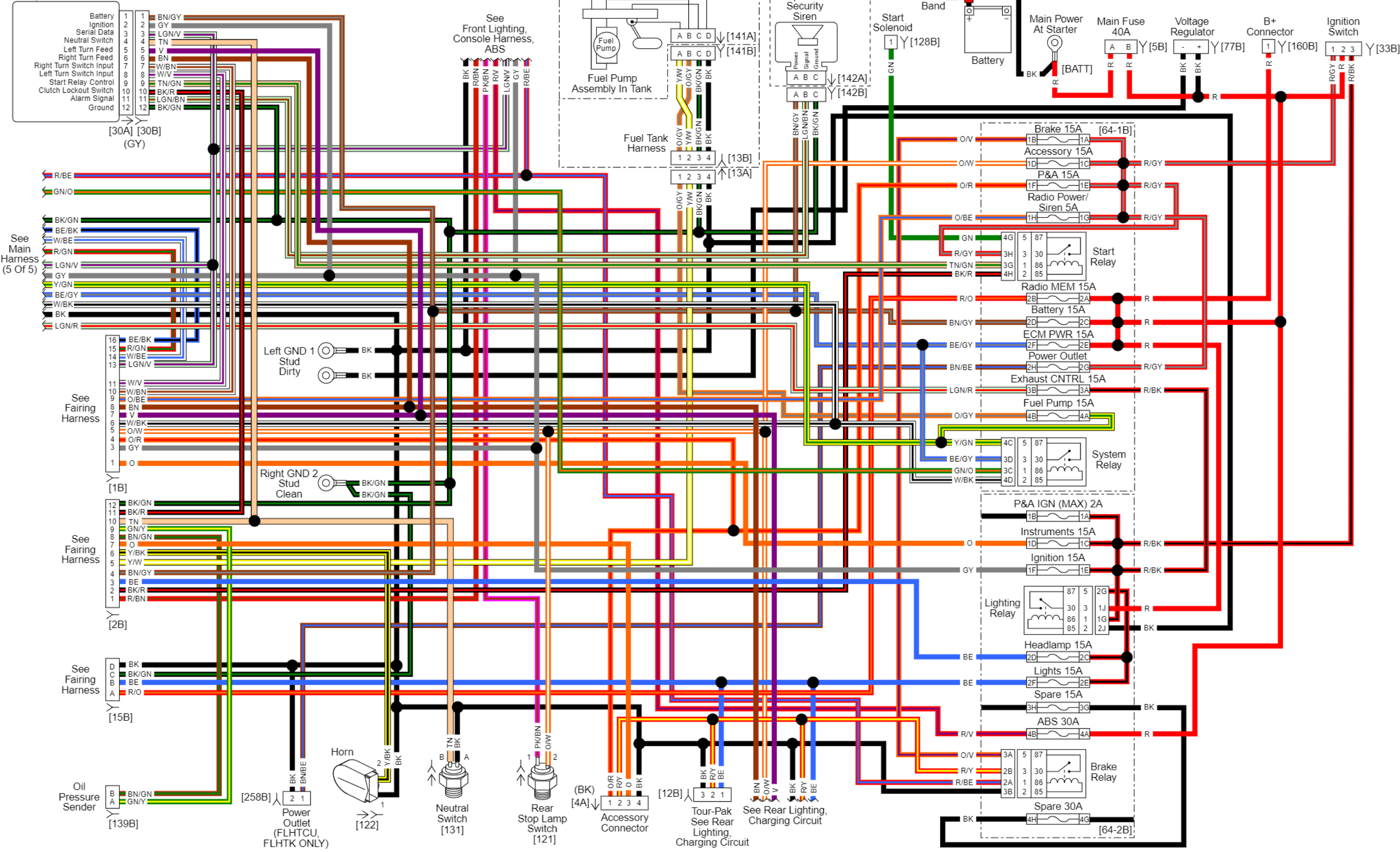

Main Harness (2 OF 5): 2012 Touring (Except FLHR/C) with ABS

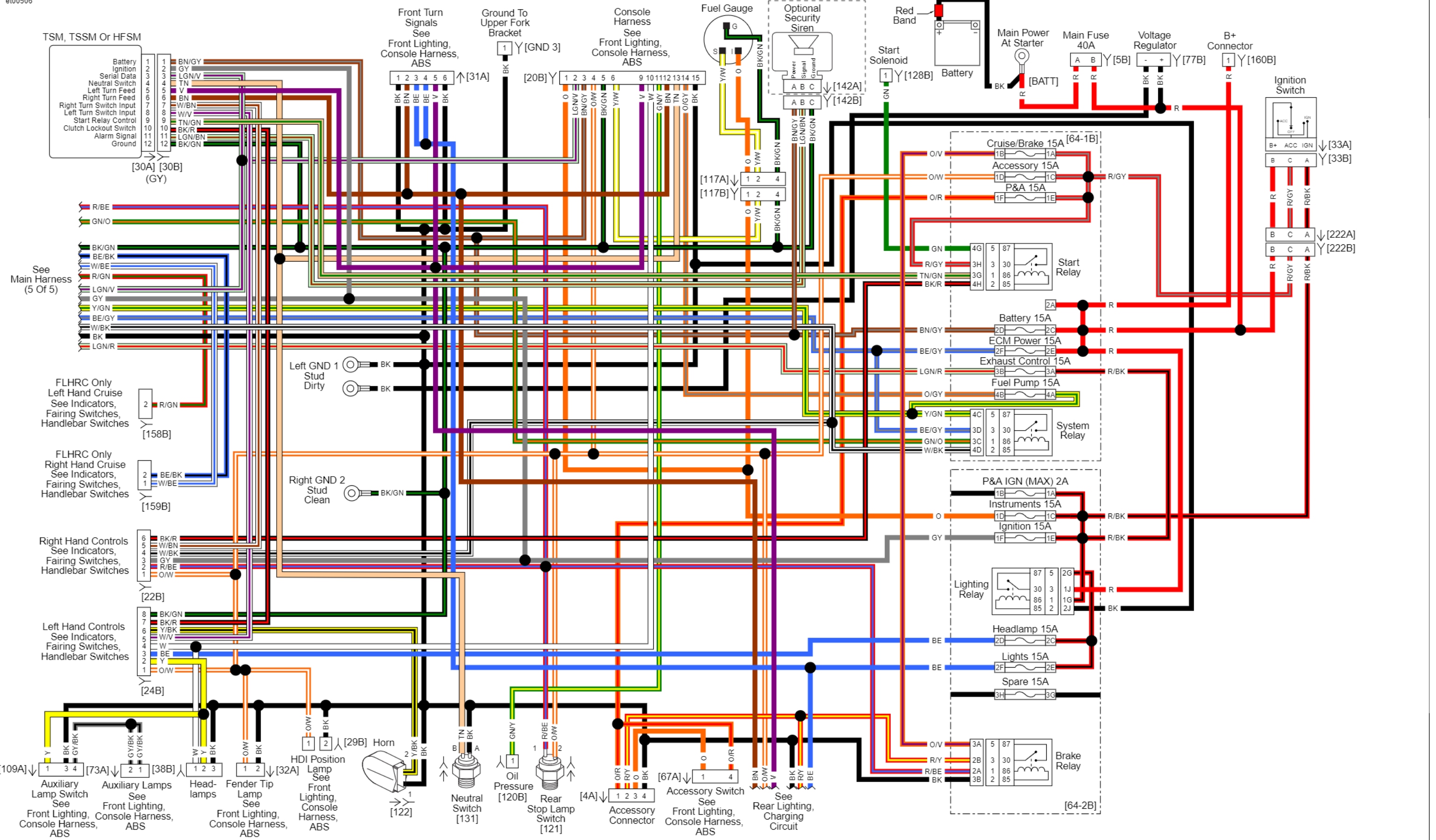

Main Harness (3 OF 5): 2012 Touring (FLHR/C) without ABS

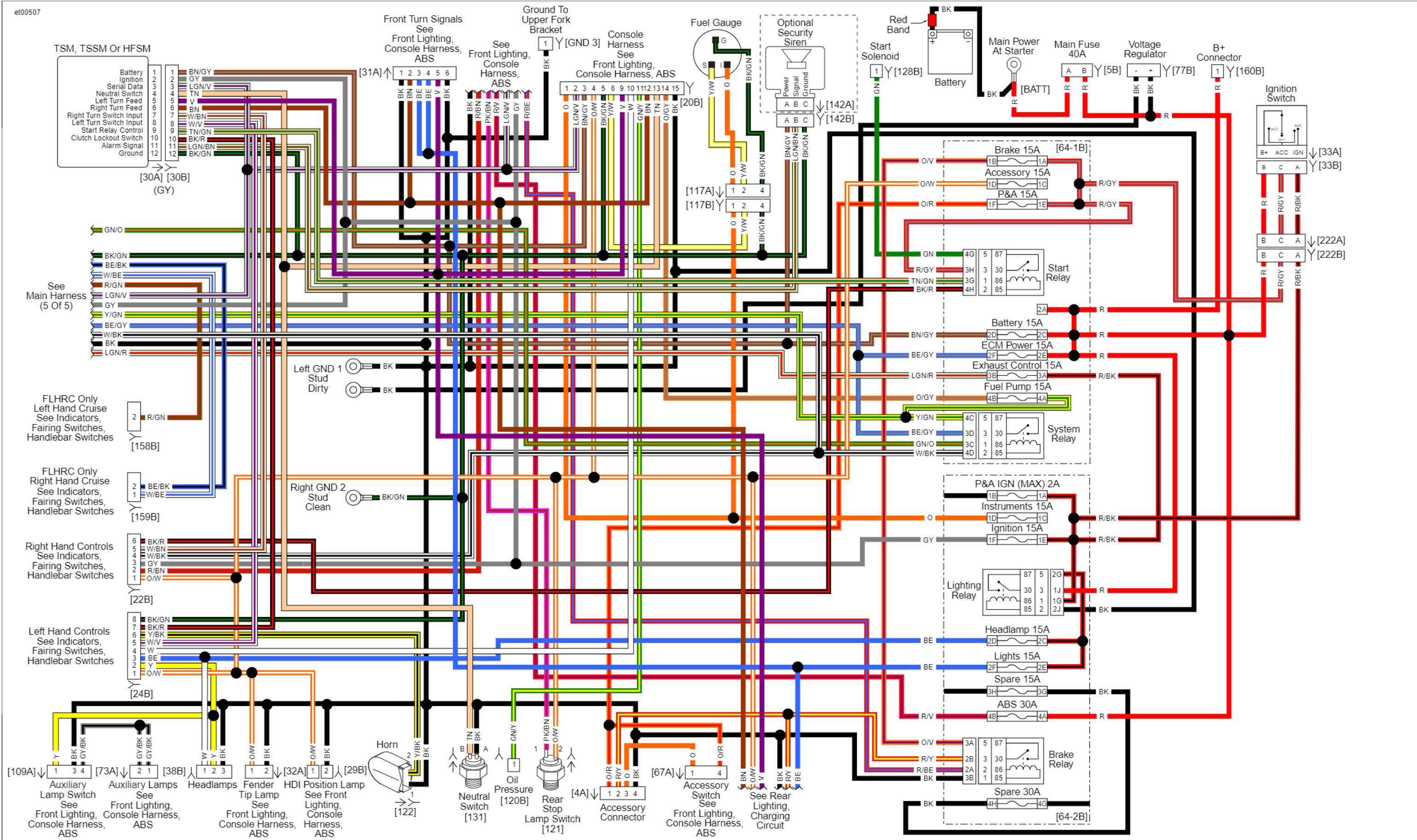

Main Harness (4 OF 5): 2012 Touring (FLHR/C) with ABS

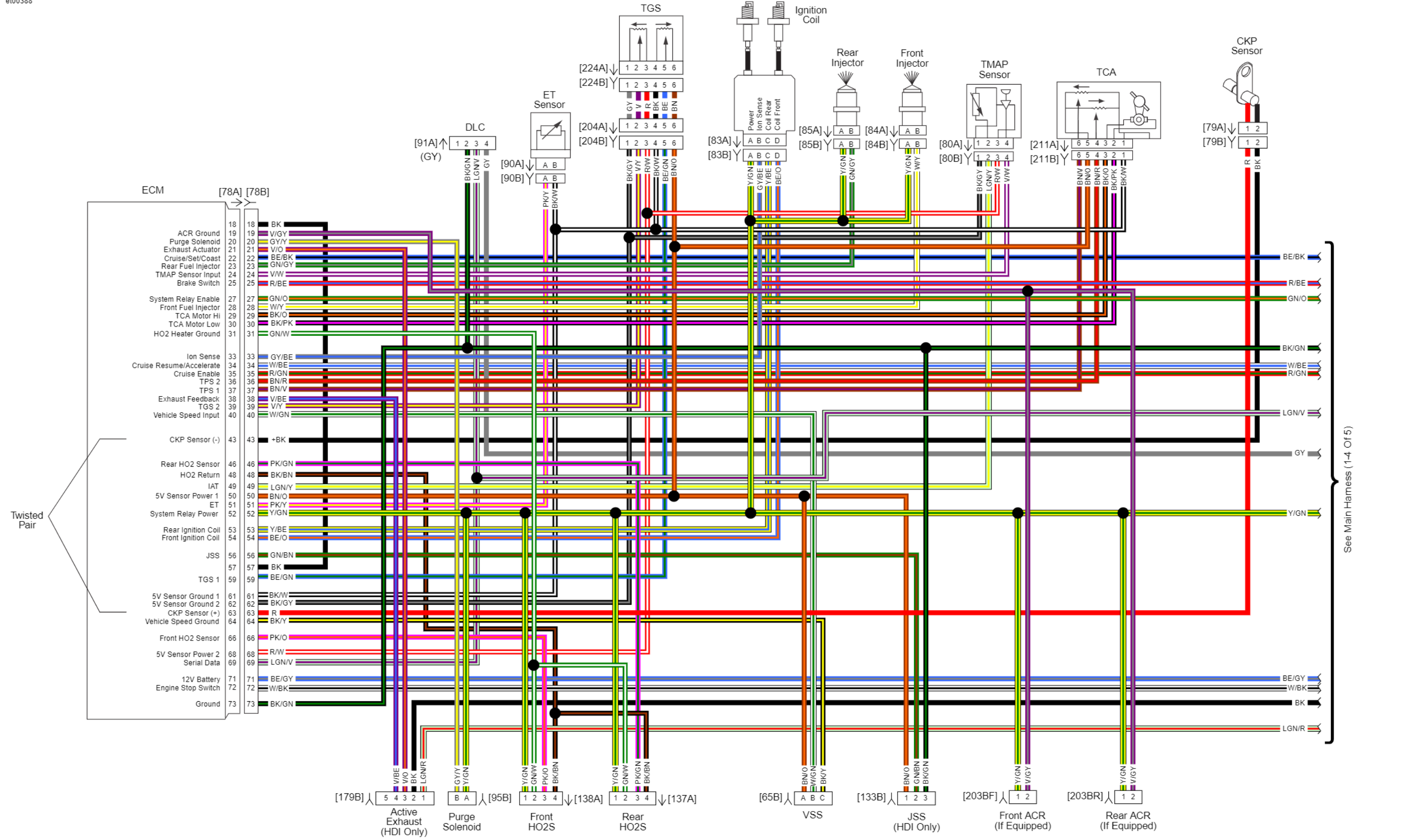

Main Harness (5 OF 5): 2012 Touring

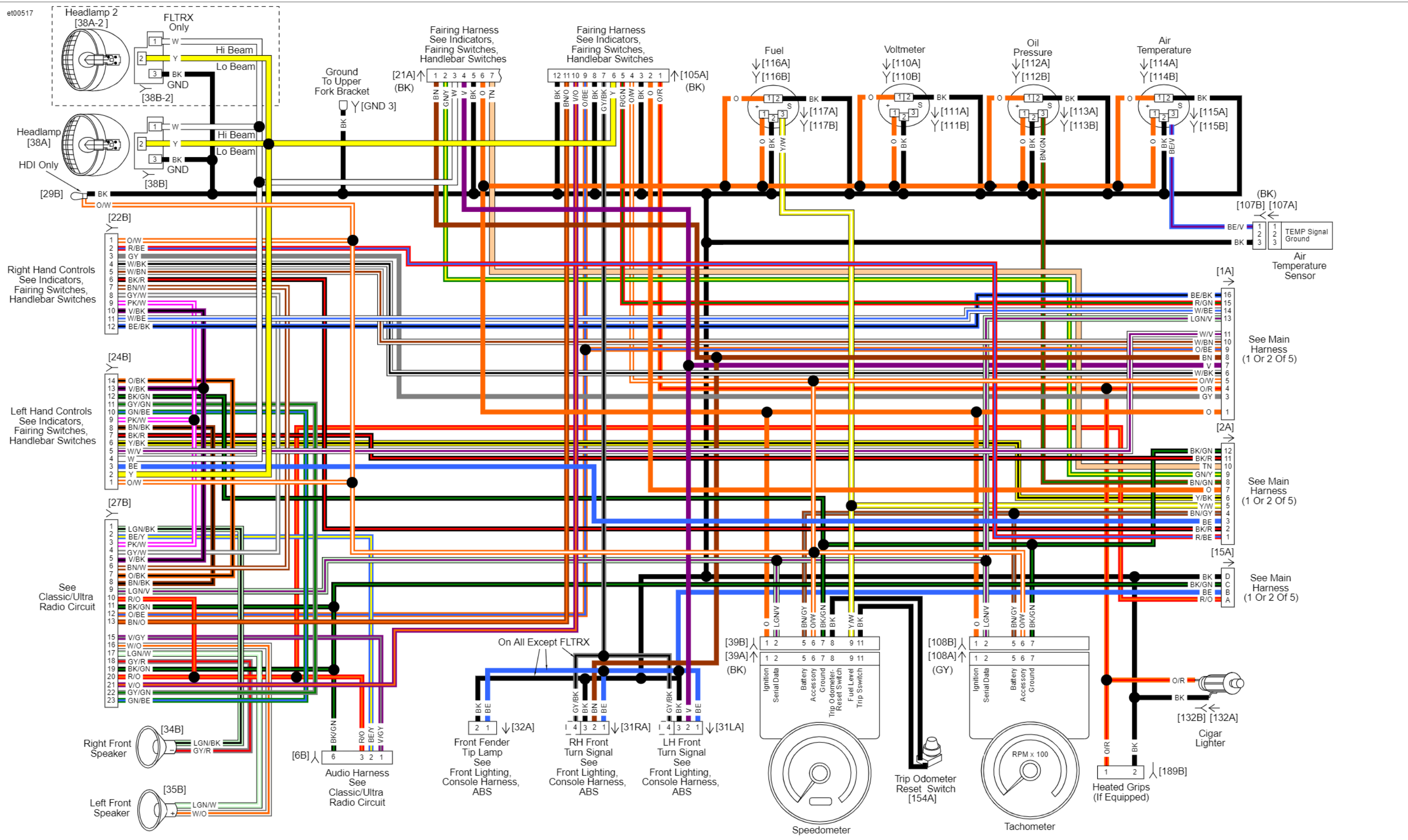

Fairing Harness: 2012 Touring

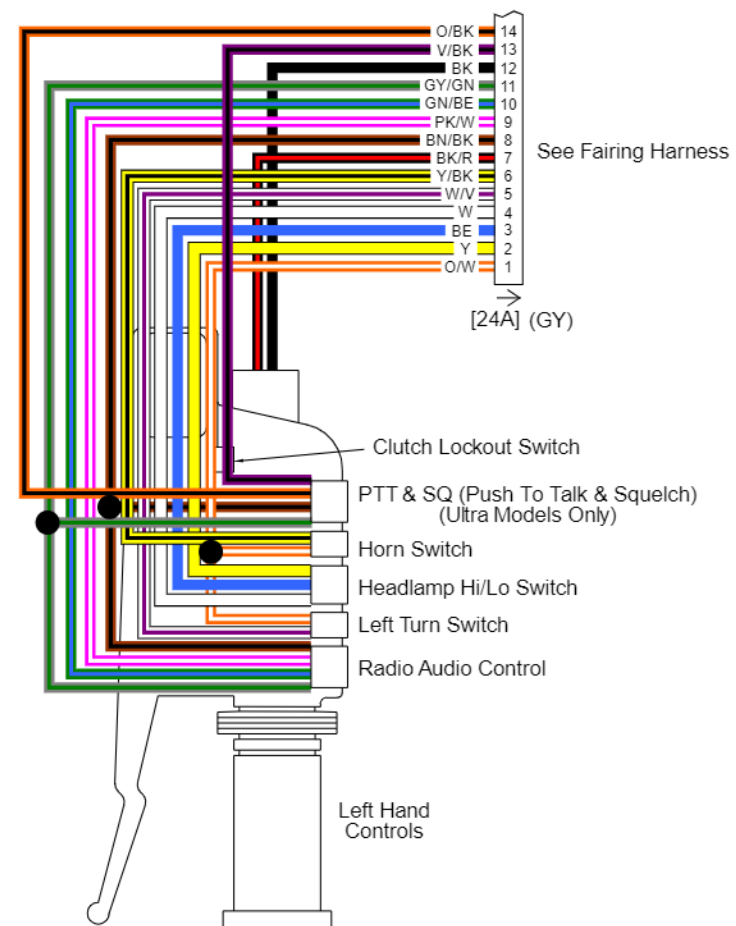
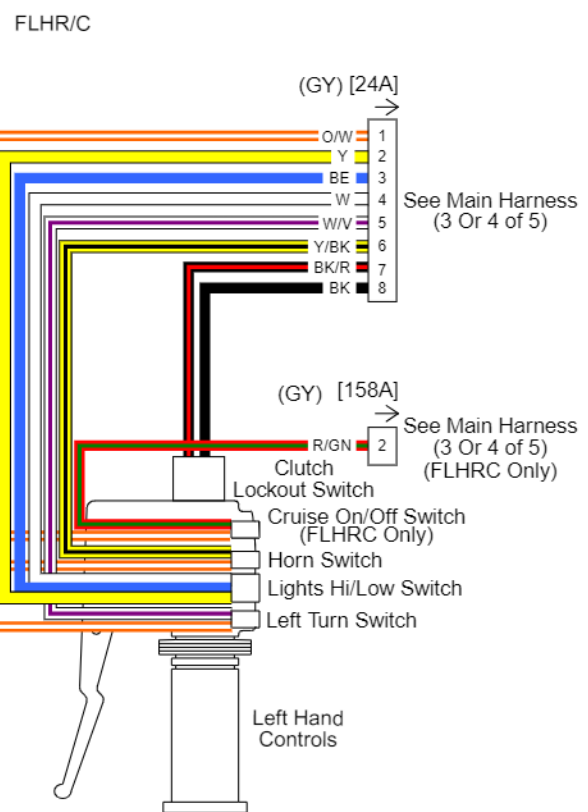
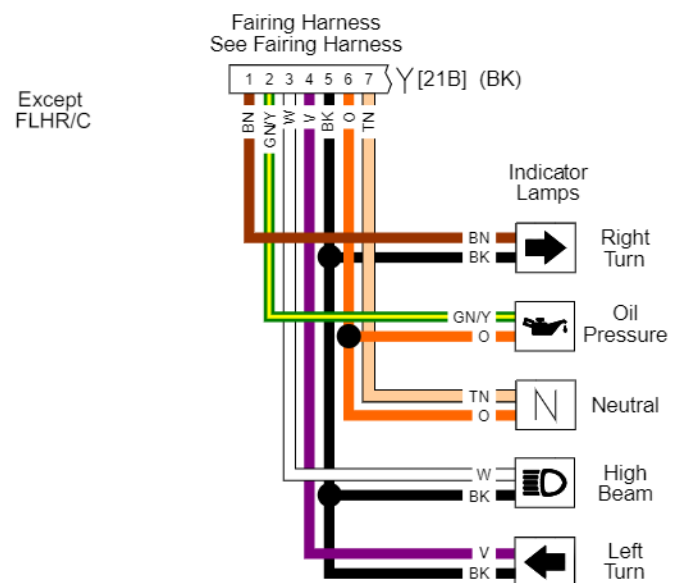
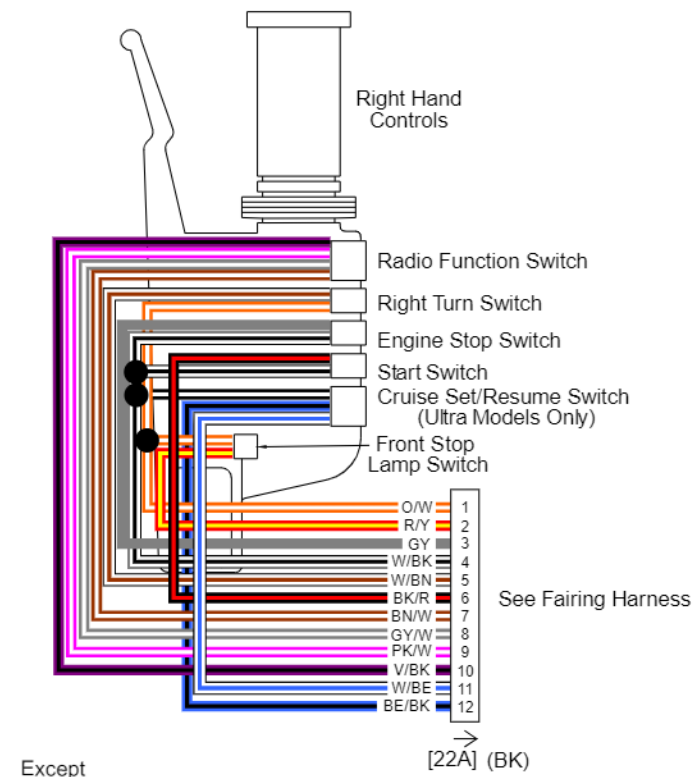
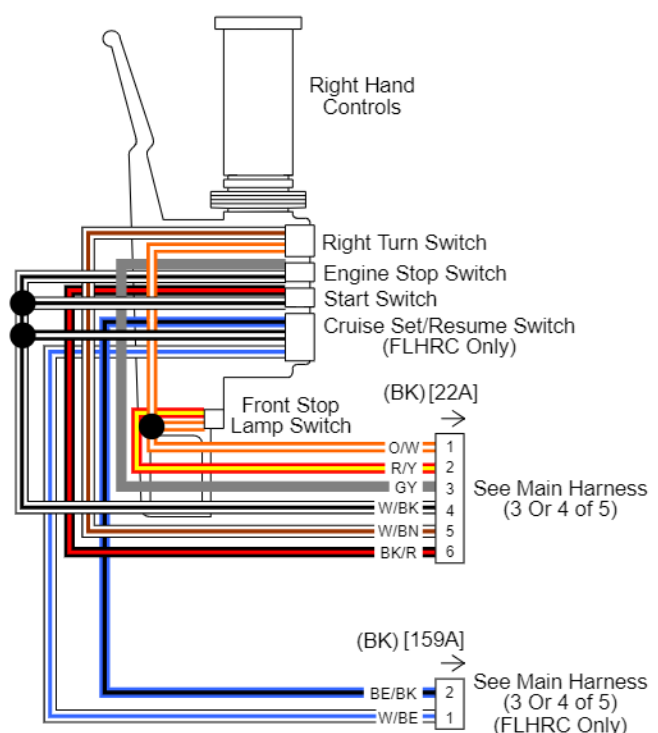
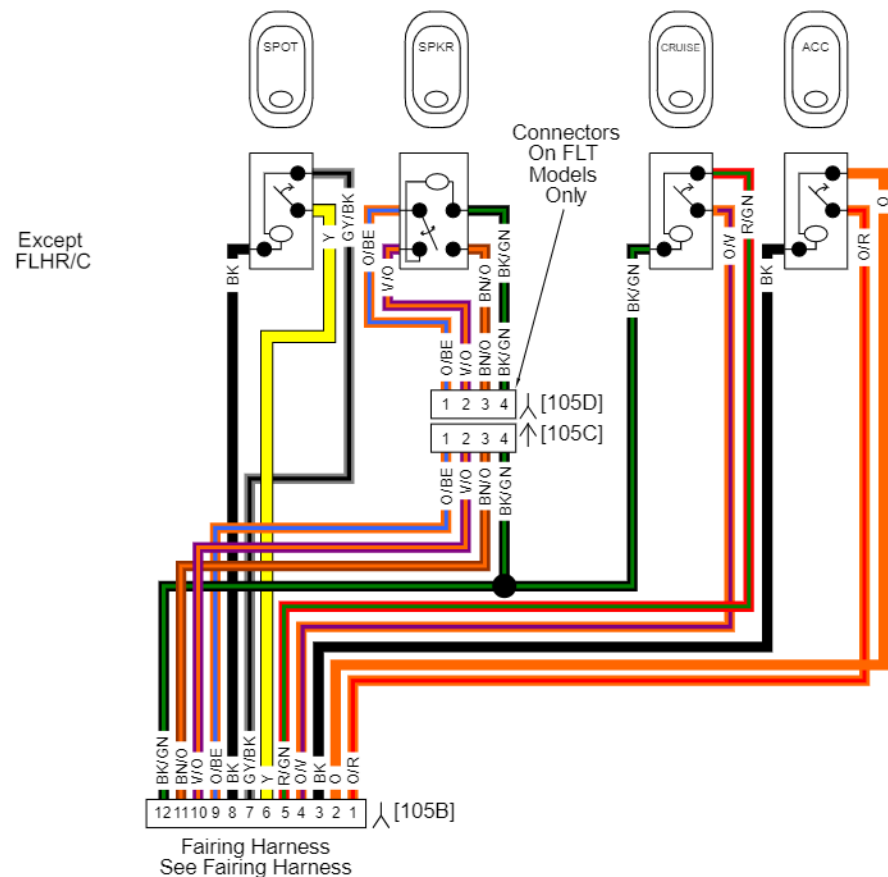

Indicators, Fairing Switches, Handlebar Switches: 2012 Touring

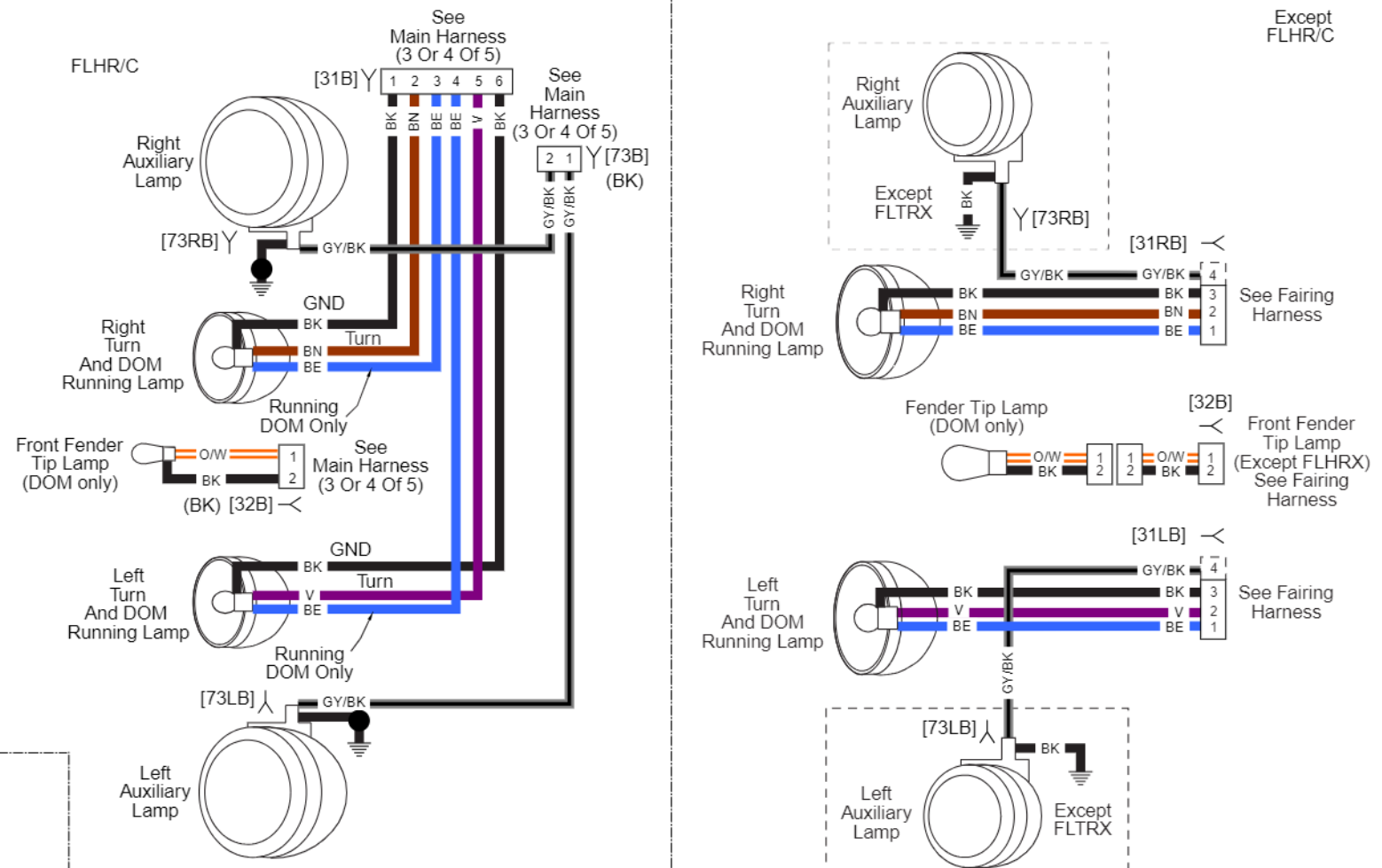
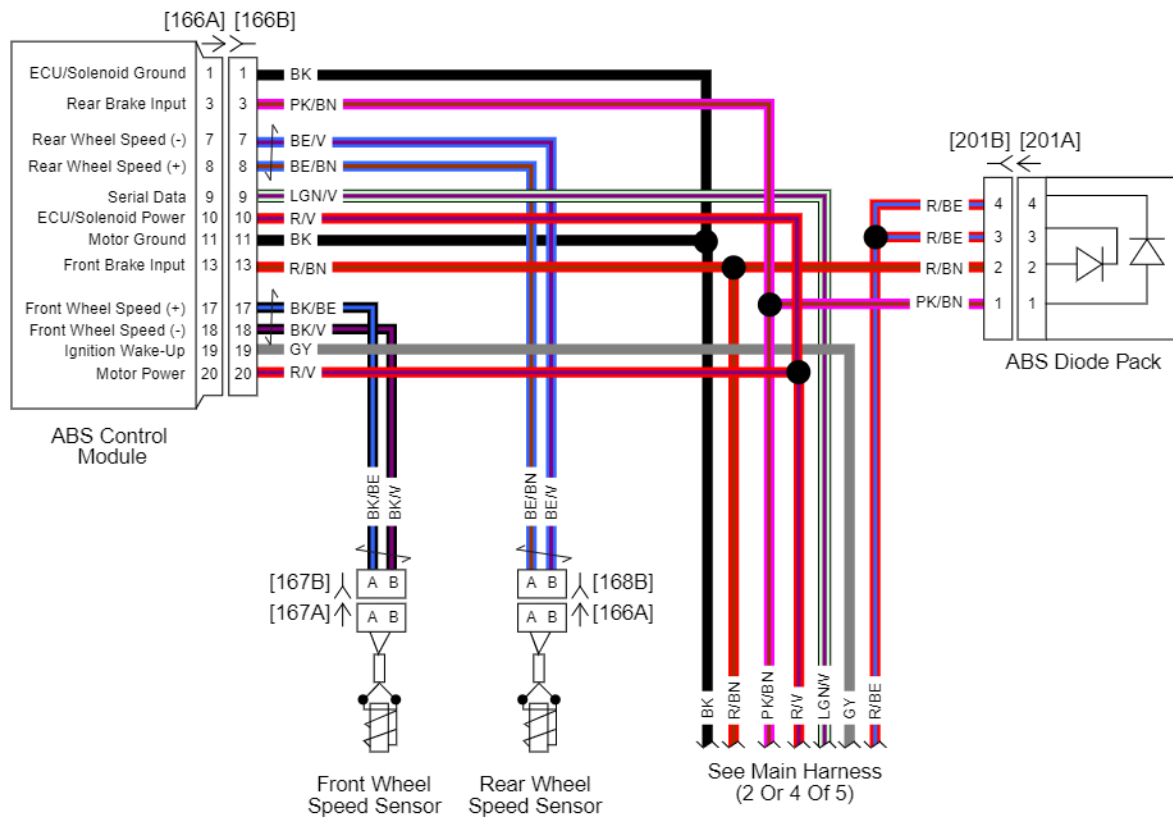

Console Harness FLHR/C

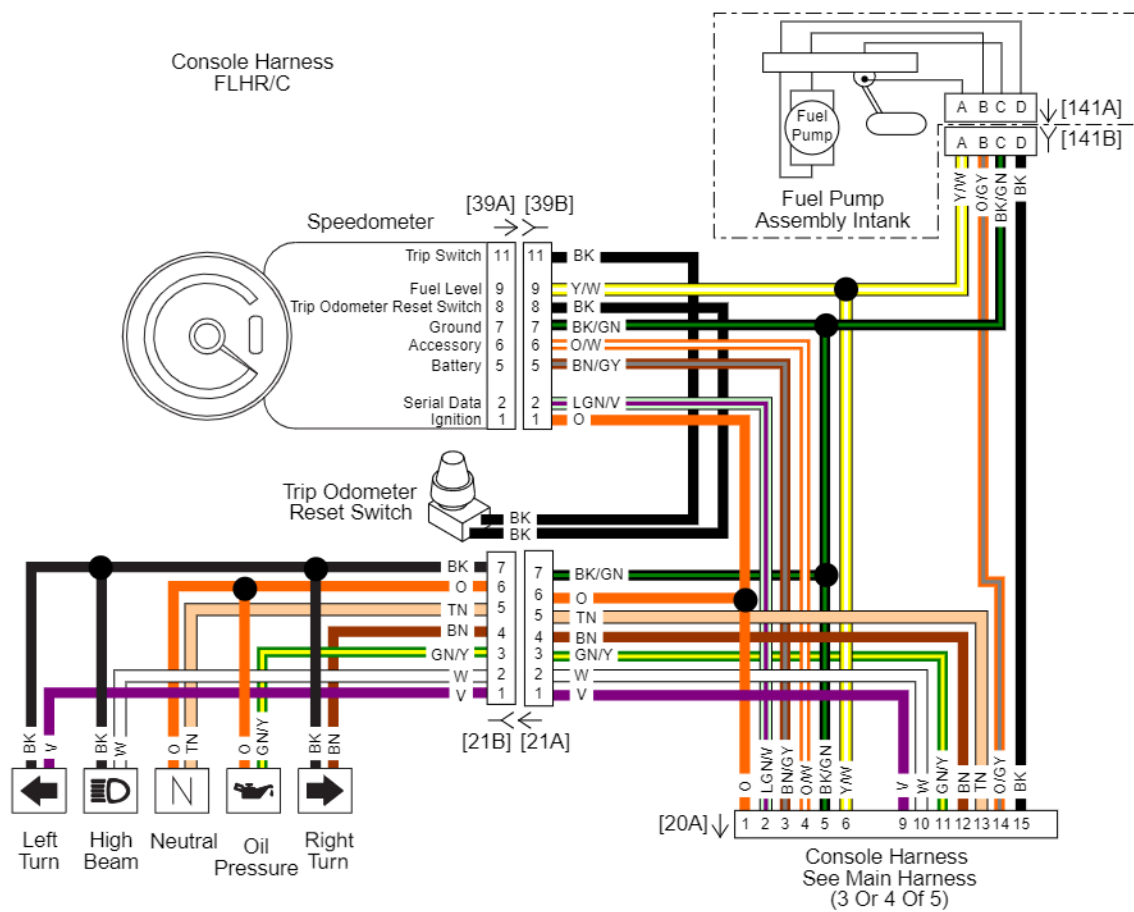

FLHR/C

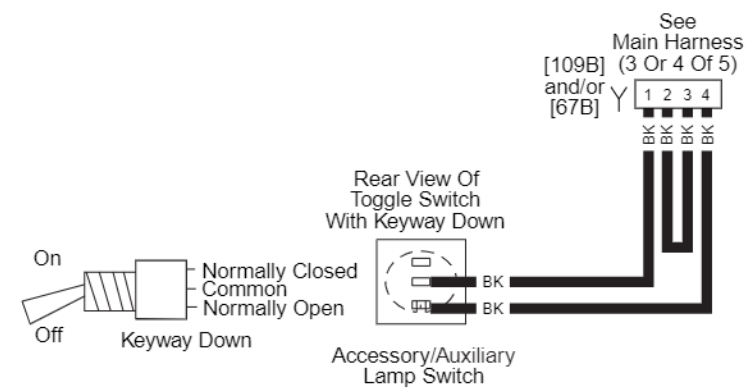

Front Lighting, Console Harness, ABS: 2012 Touring

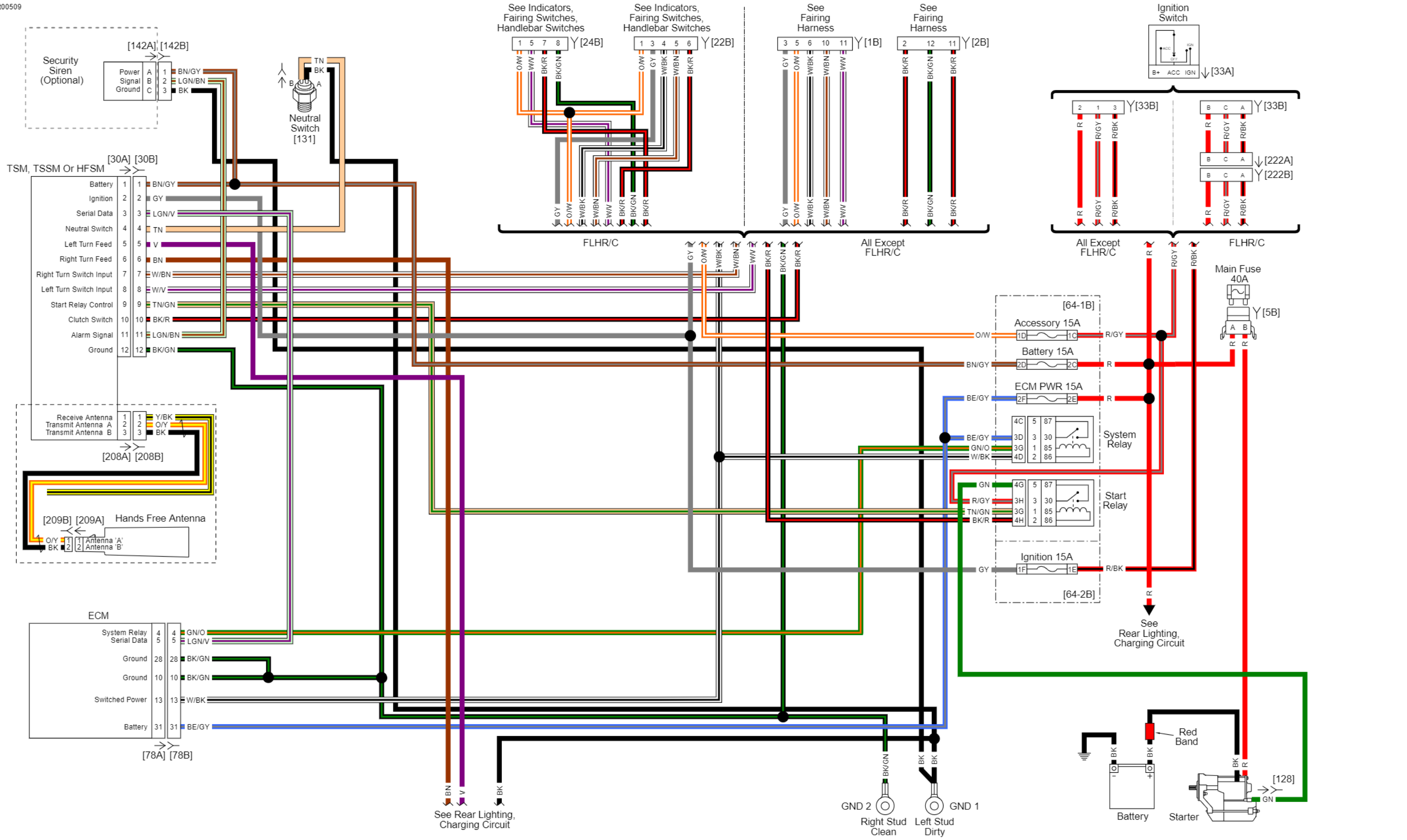

Security Circuit: 2012 Touring

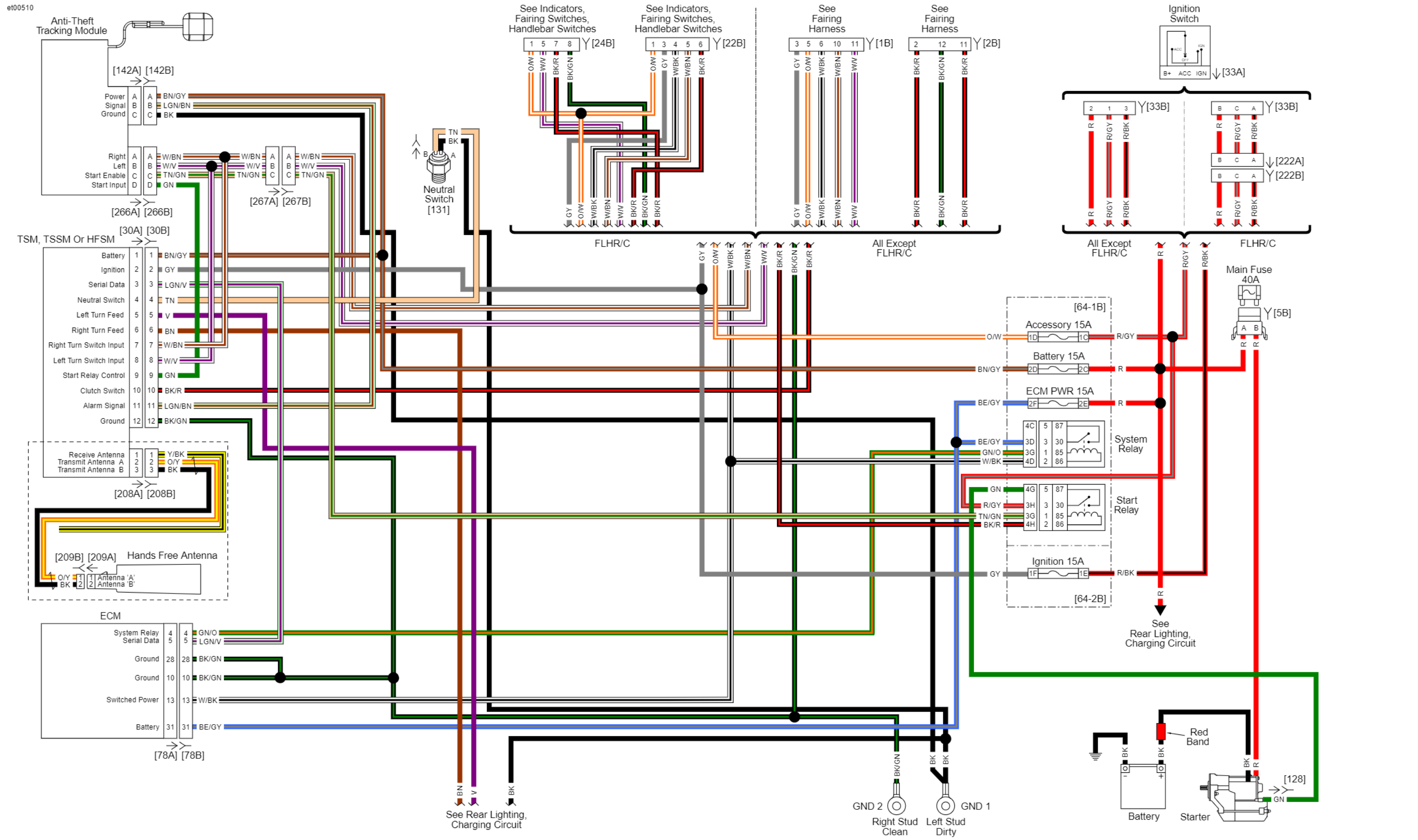

Security Circuit: 2012 Touring With Anti-Theft Tracking Module

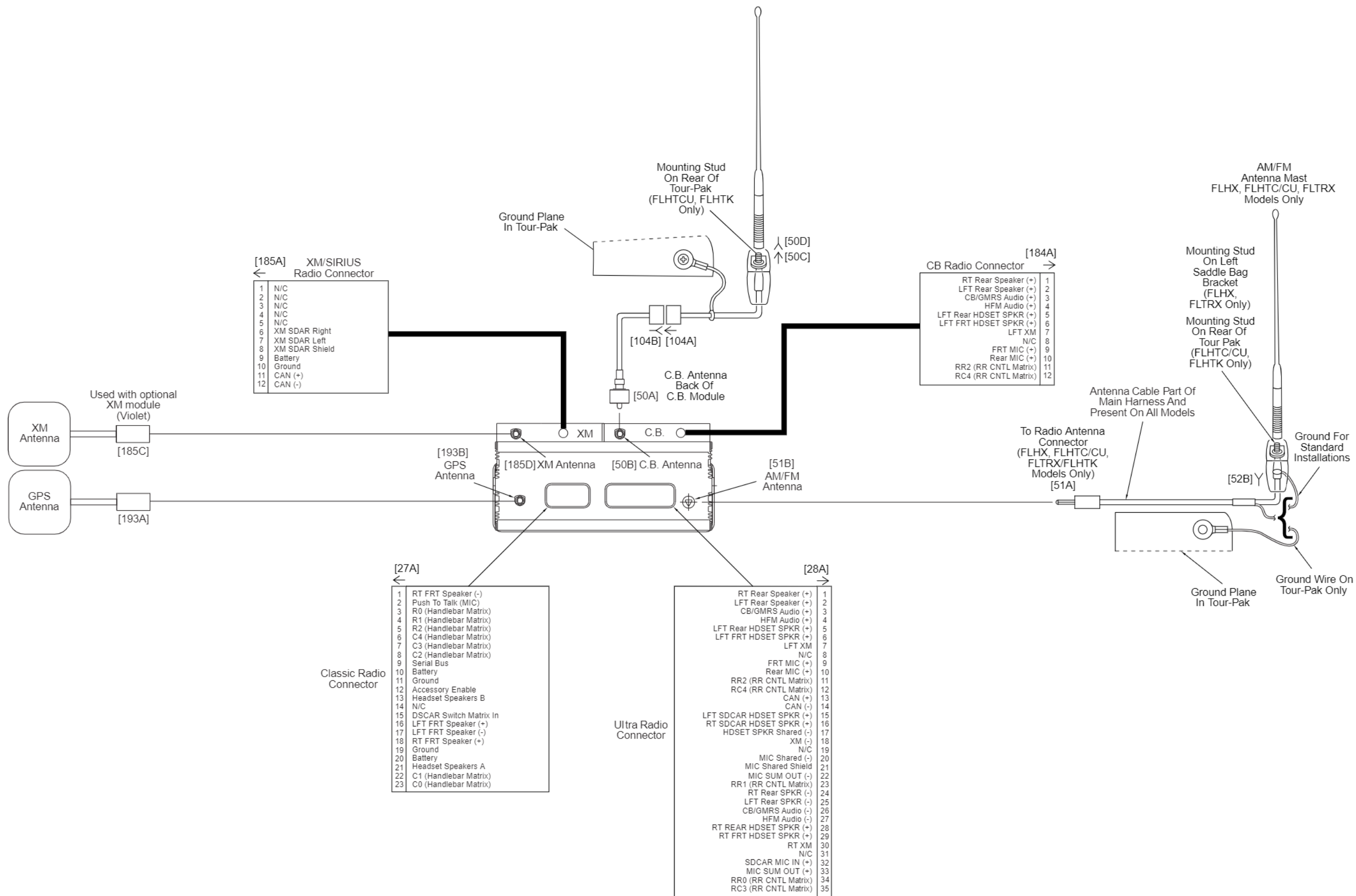

Ultra Radio RF Interconnect Circuit: 2012 Touring

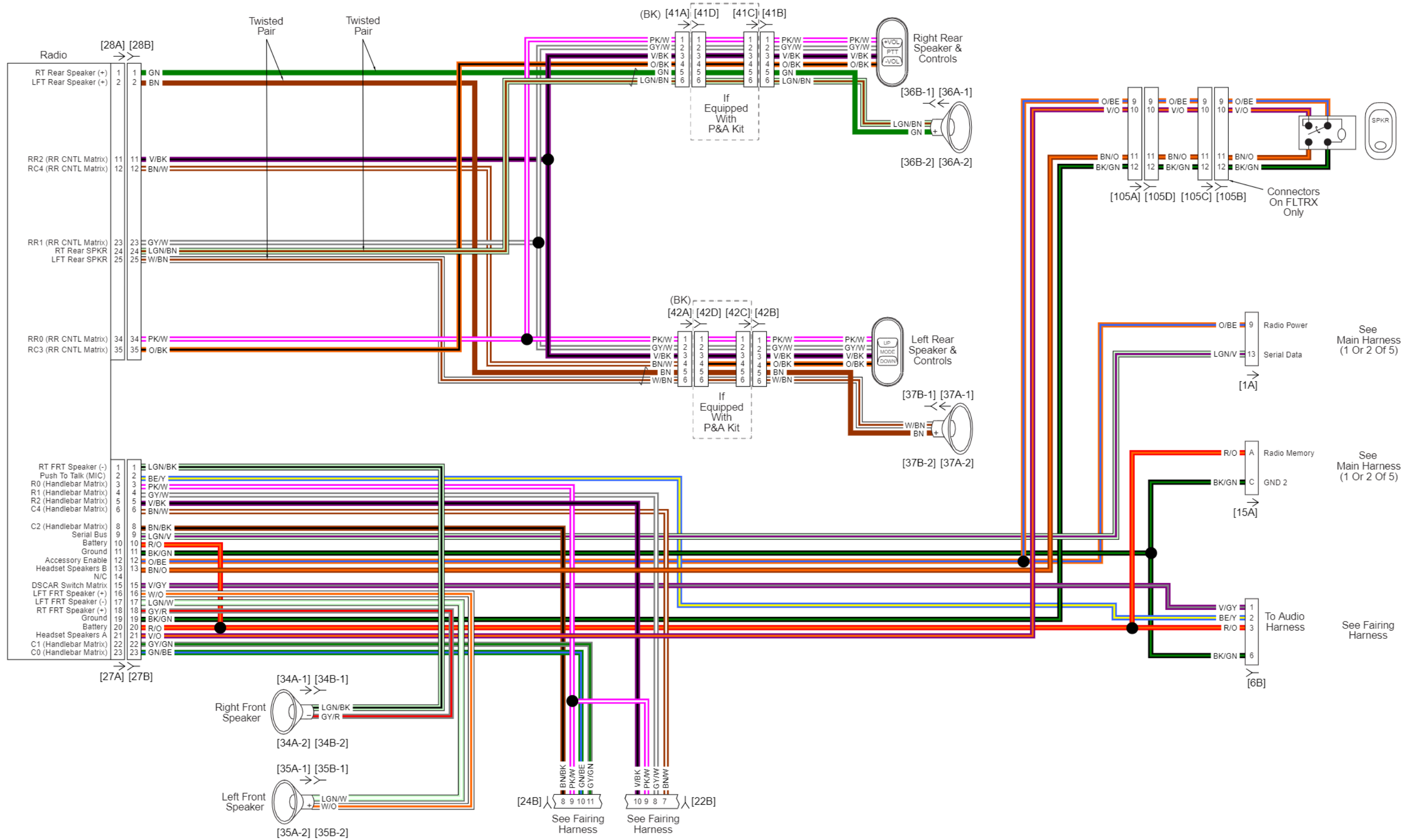

Classic Radio Circuit: 2012 Touring

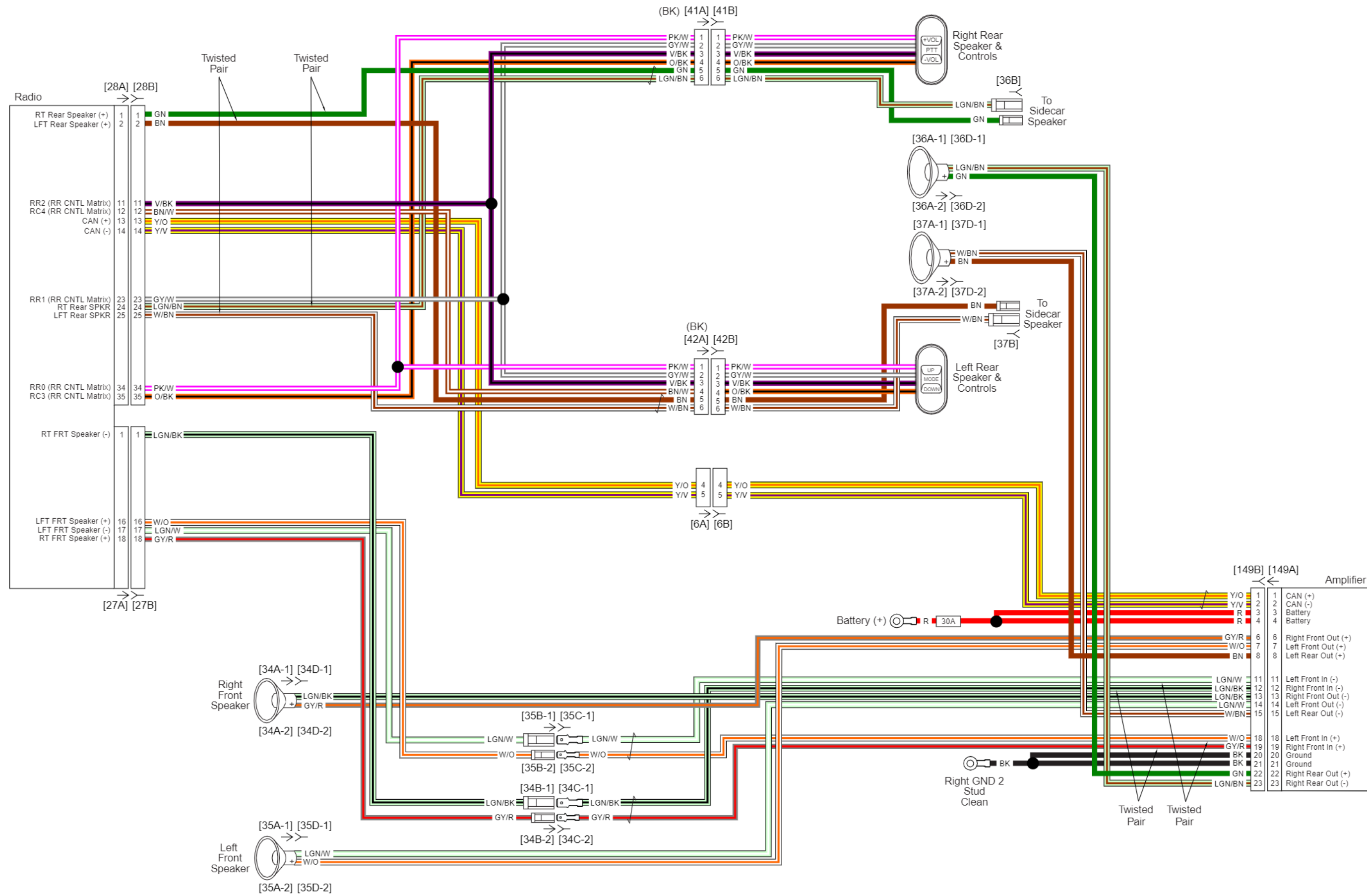

Ultra Radio Circuit: 2012 Touring

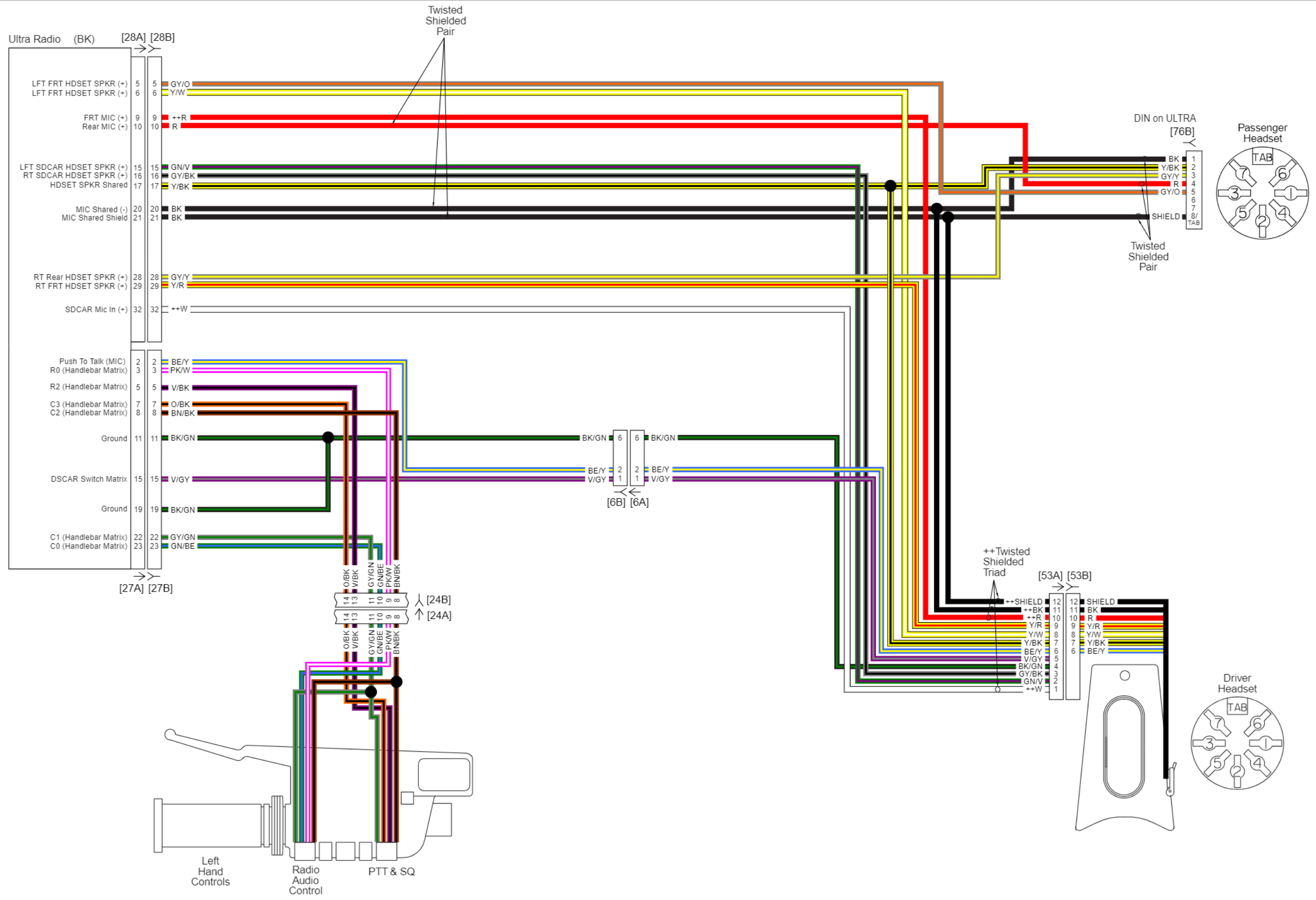

2-Place Intercom and Headset Audio: 2012 Touring

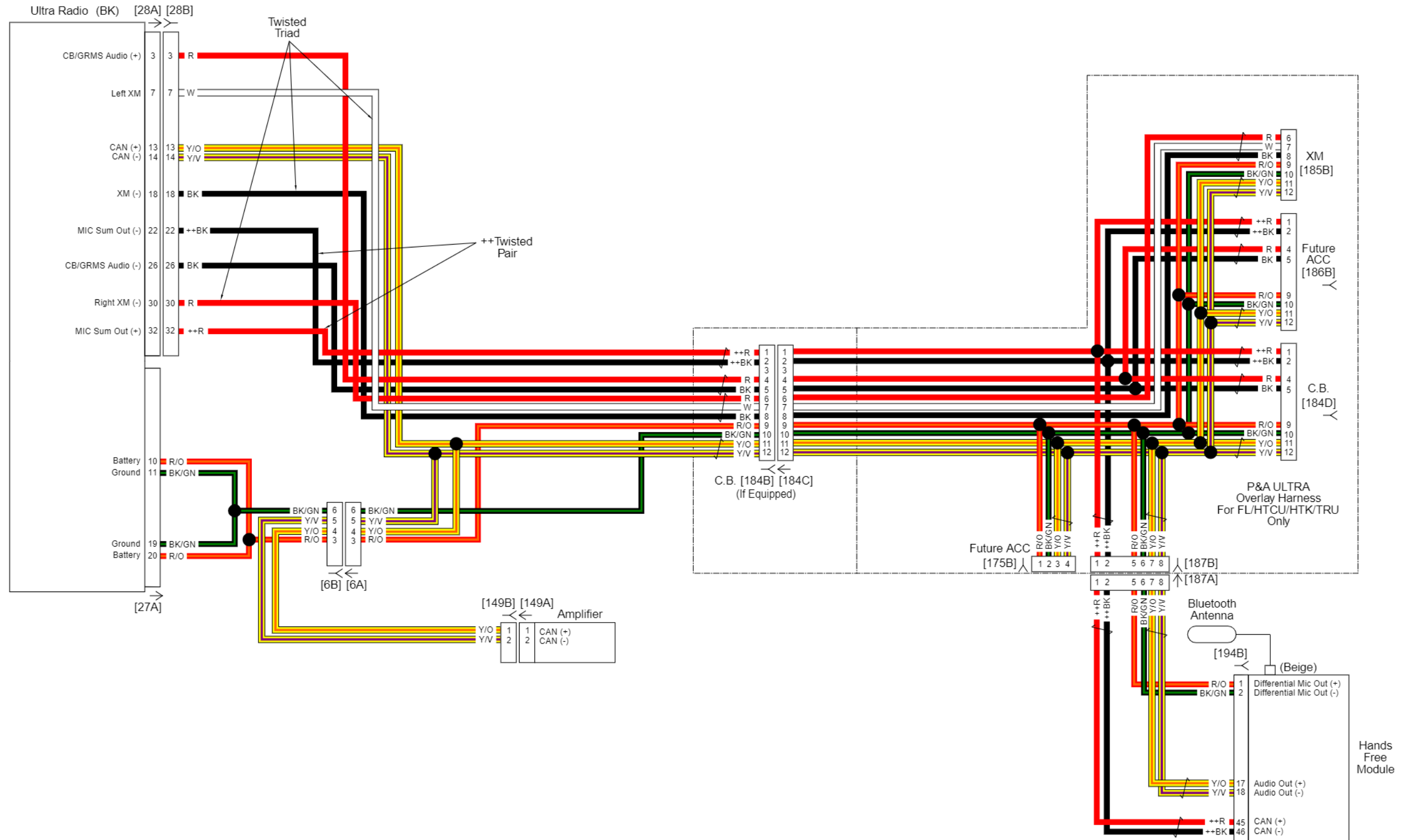

CAN and Module Audio Inputs to Ultra Radio: 2012 Touring

TSM, TSSM Or HFSM

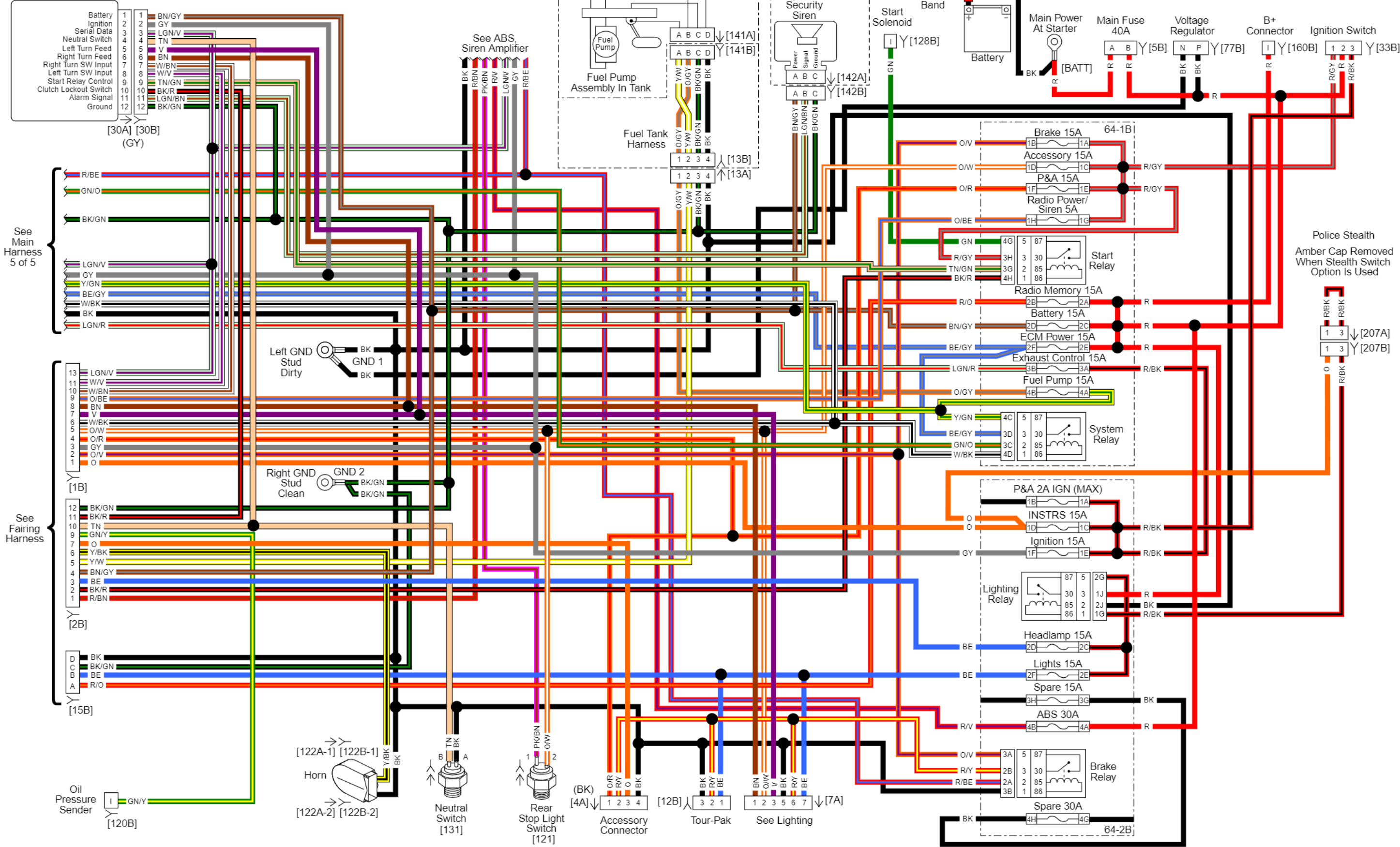

Main Harness (1 of 3): 2012 FLHTP

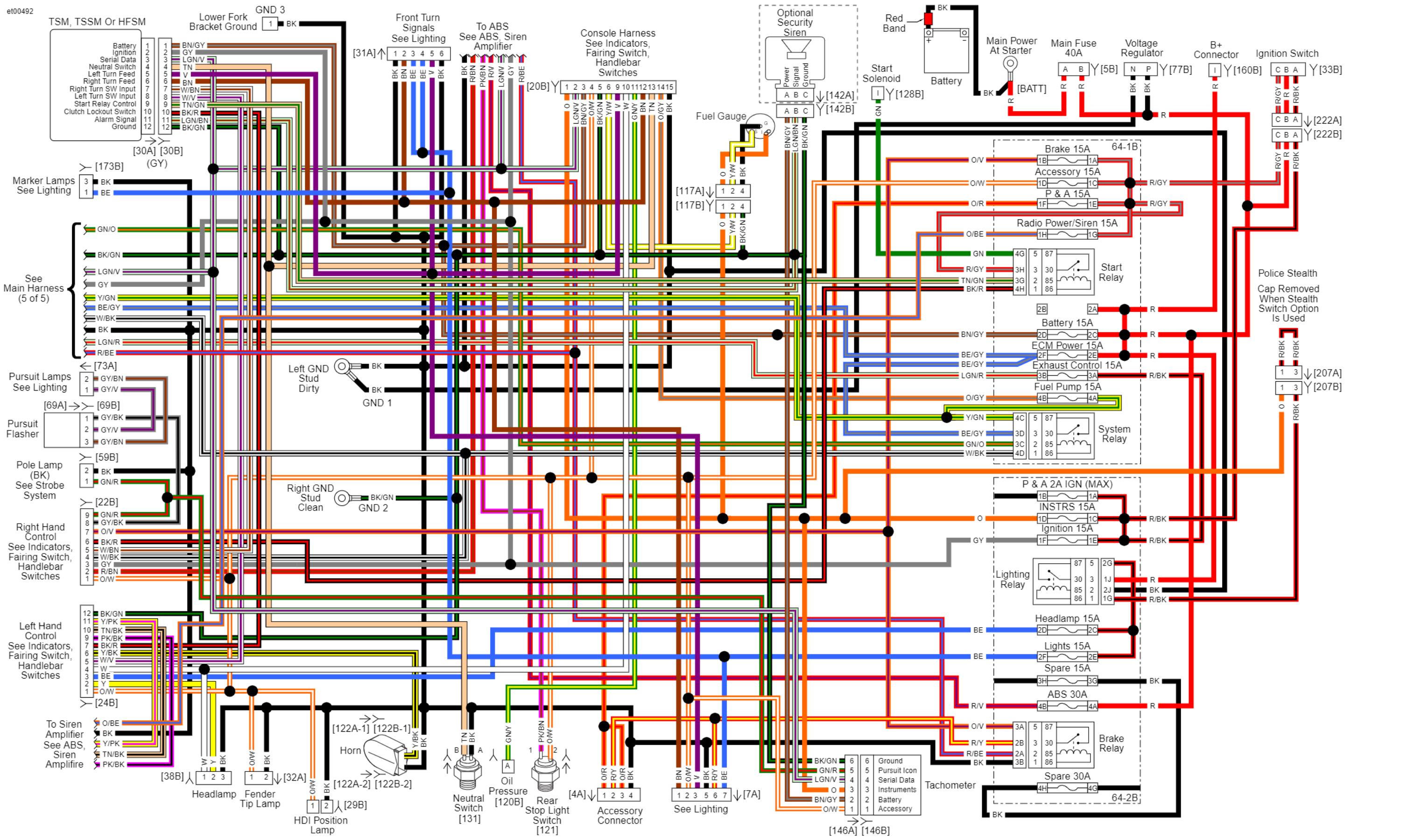

Main Harness (2 of 3): 2012 FLHP

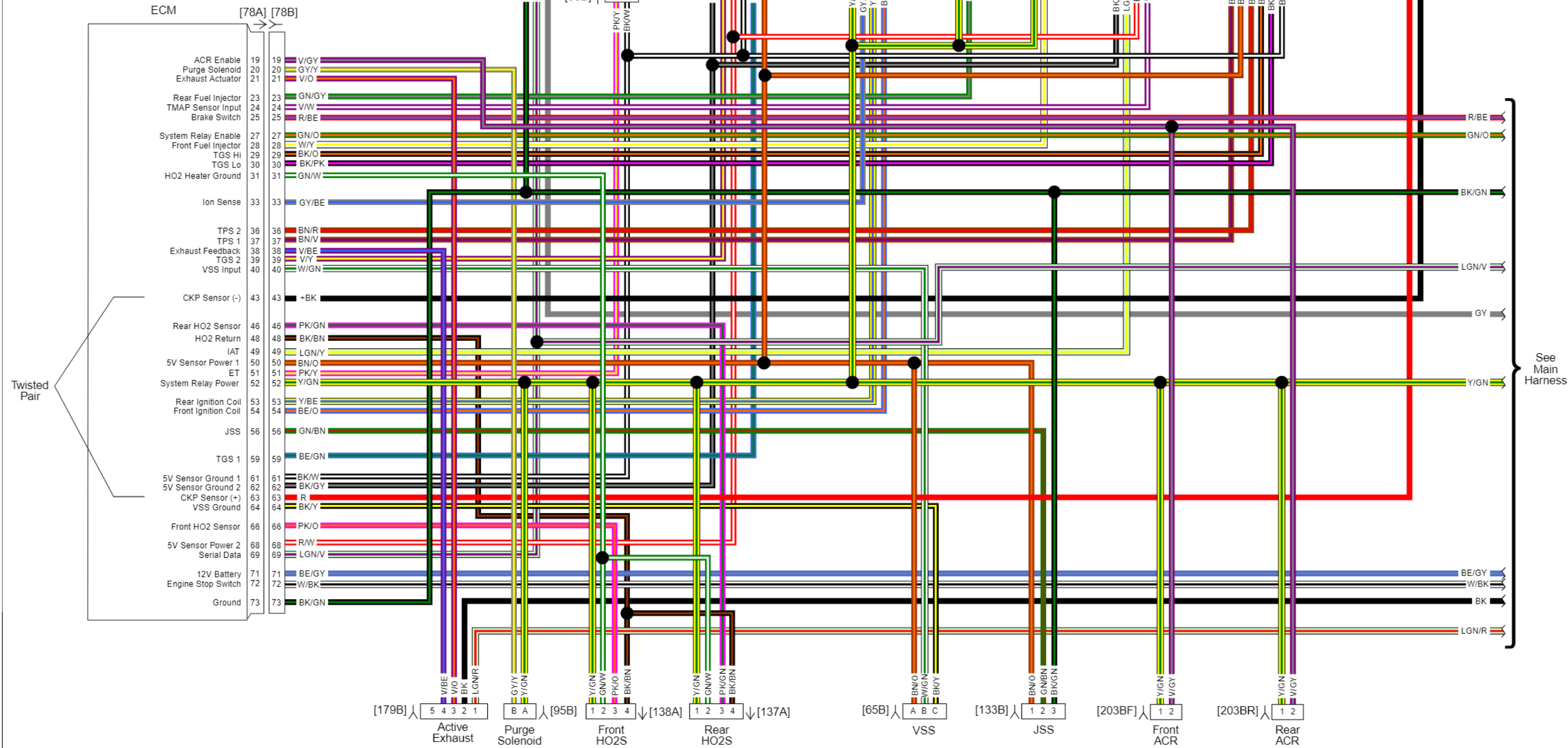

Main Harness (3 of 3): 2012 FLHTP, FLHP

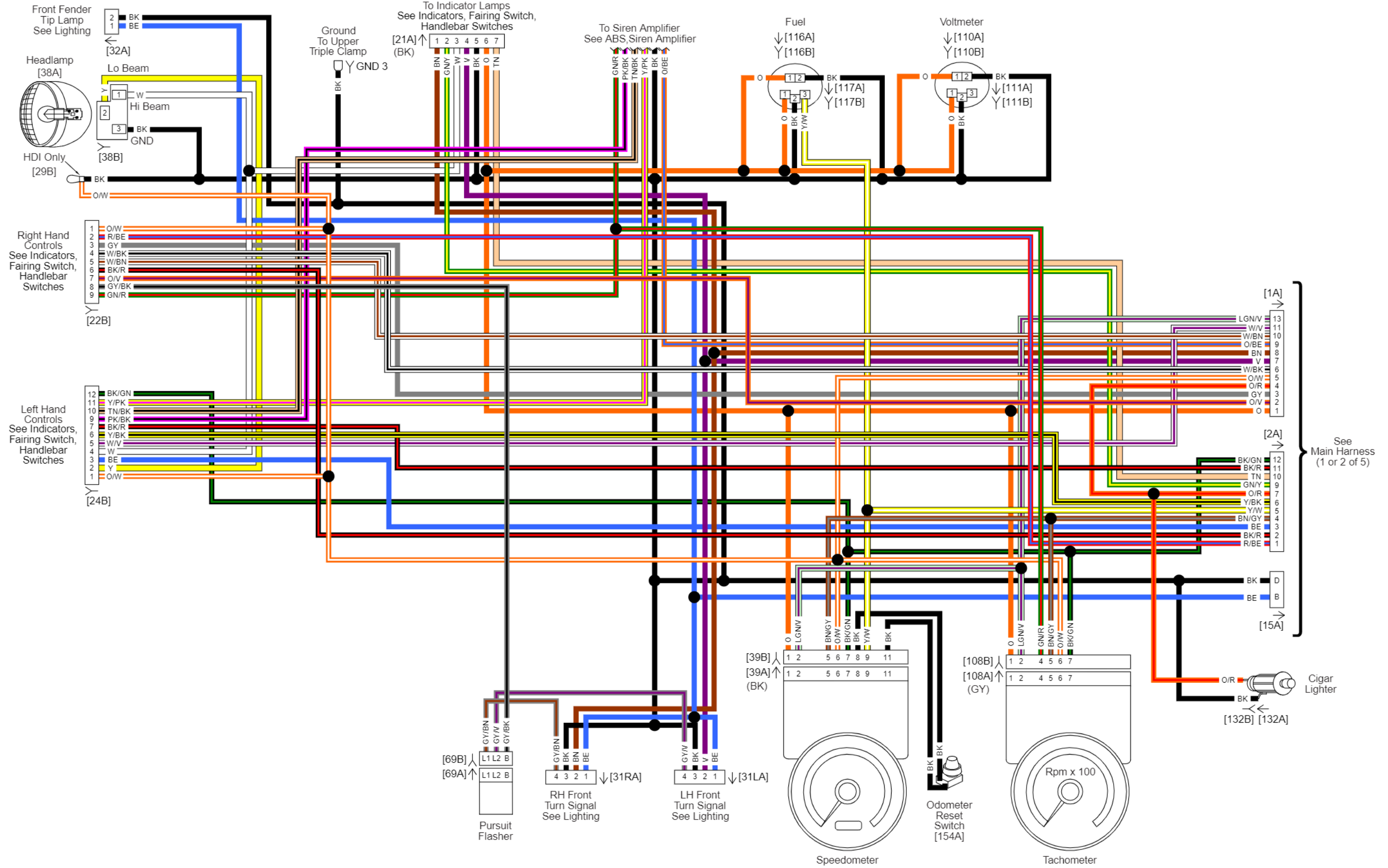

Fairing Harness: 2012 FLHTP

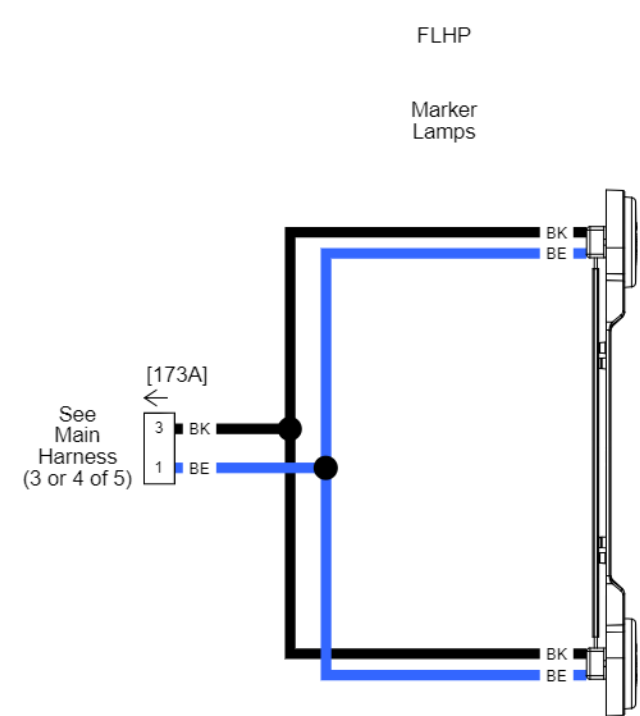
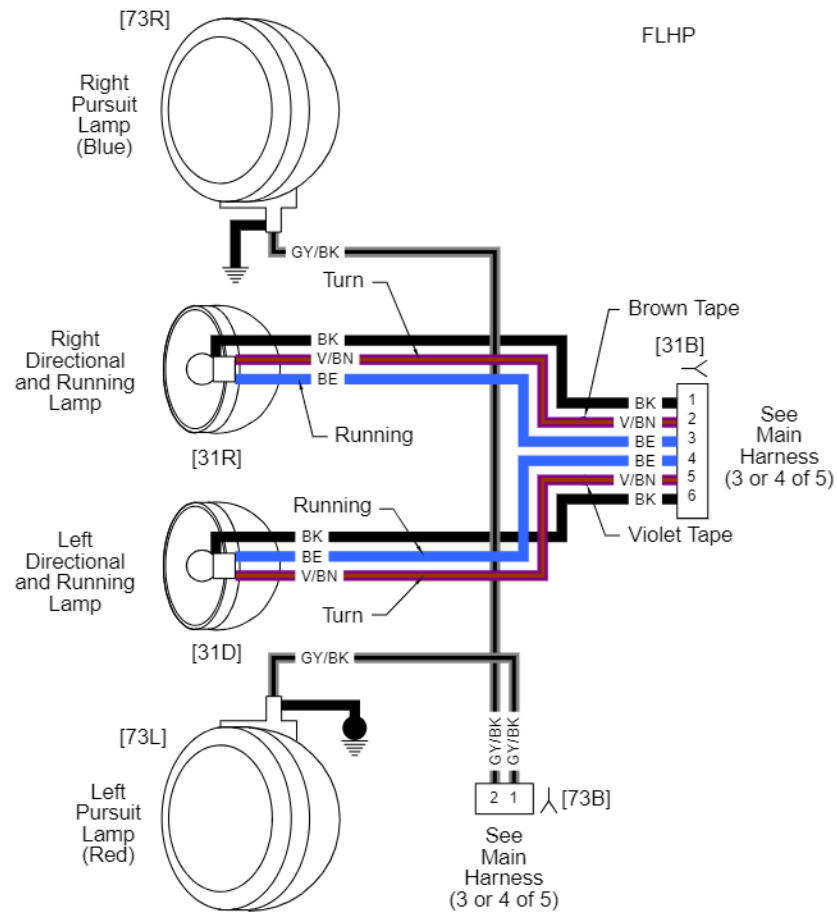
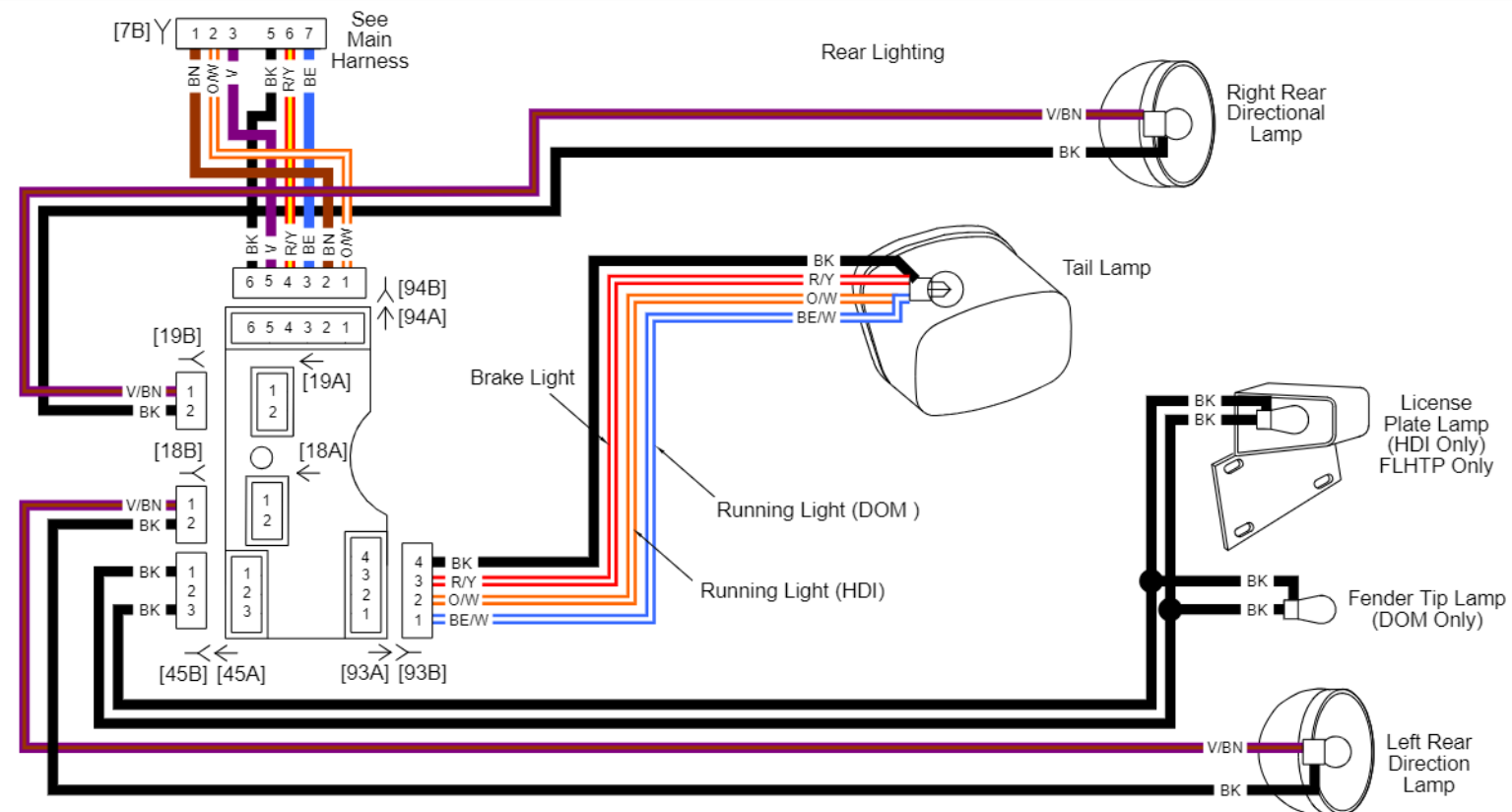
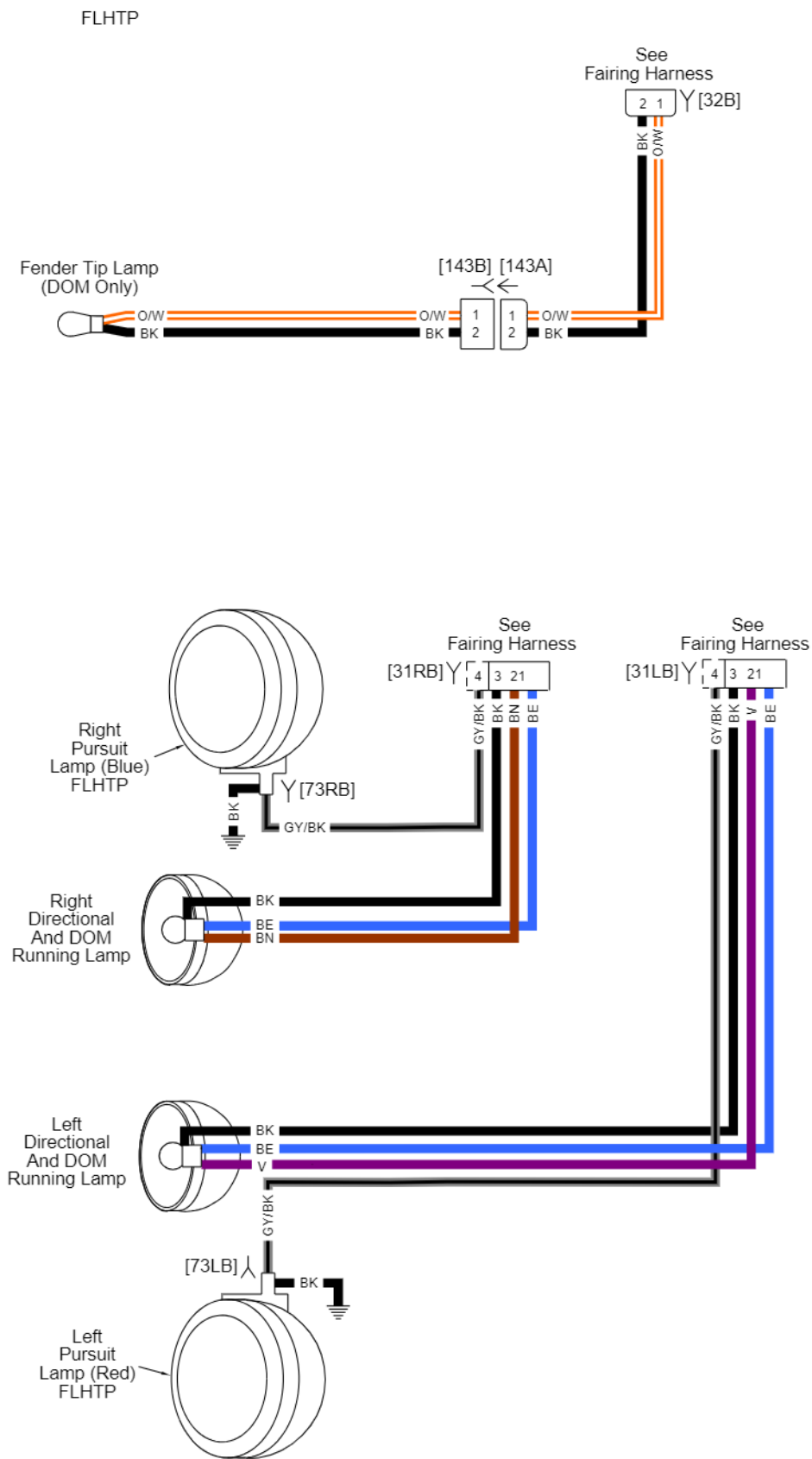

Lighting: 2012 FLHTP, FLHP

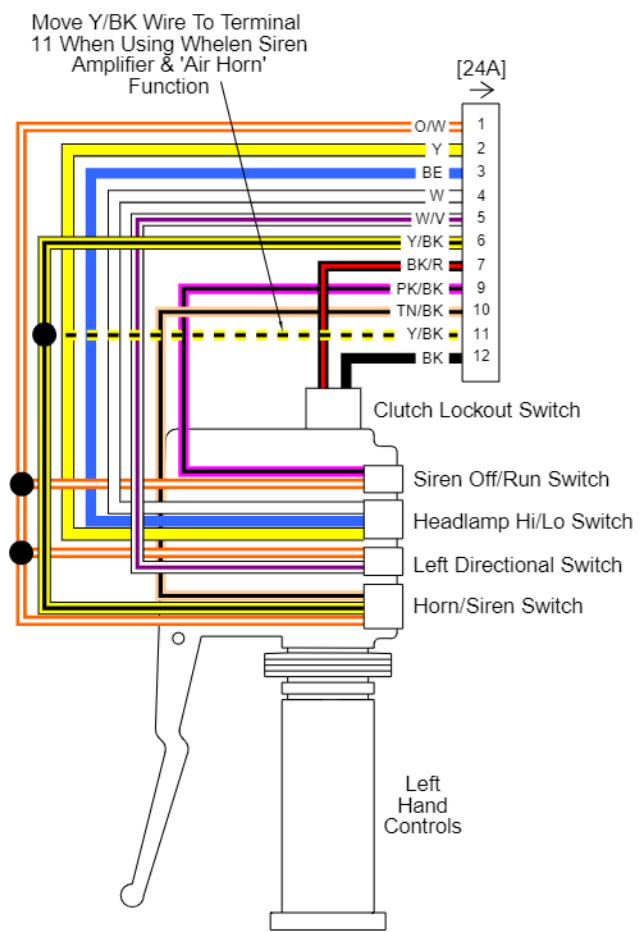
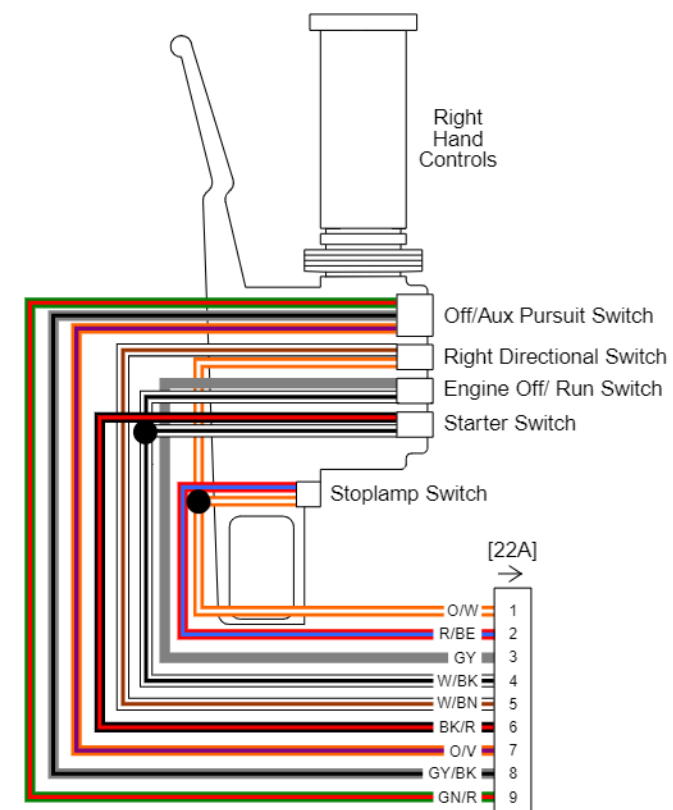
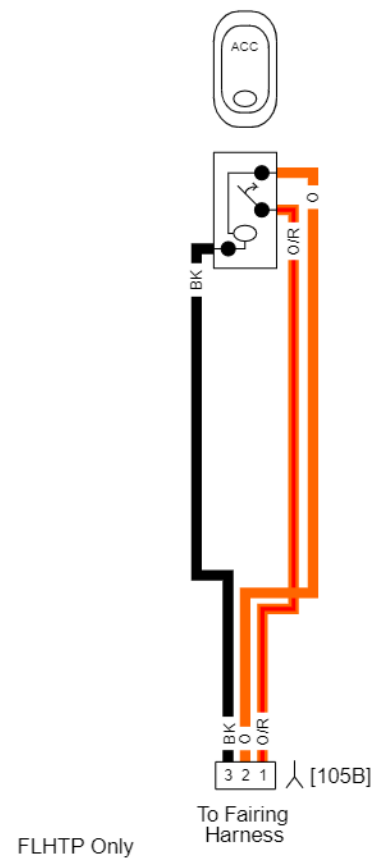
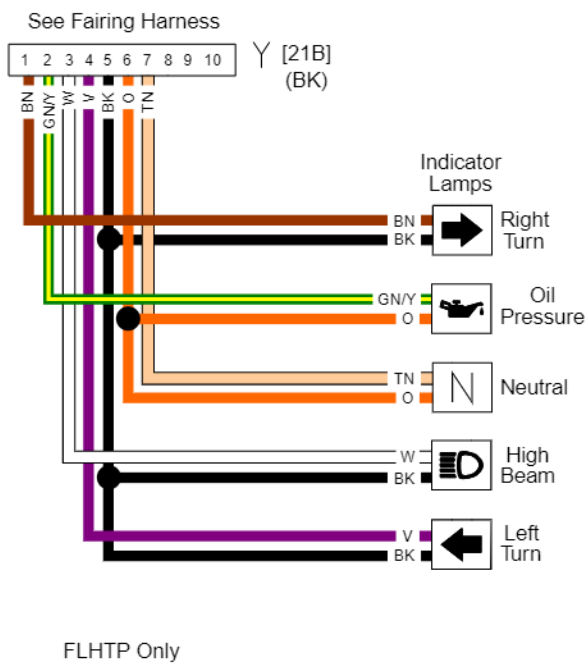
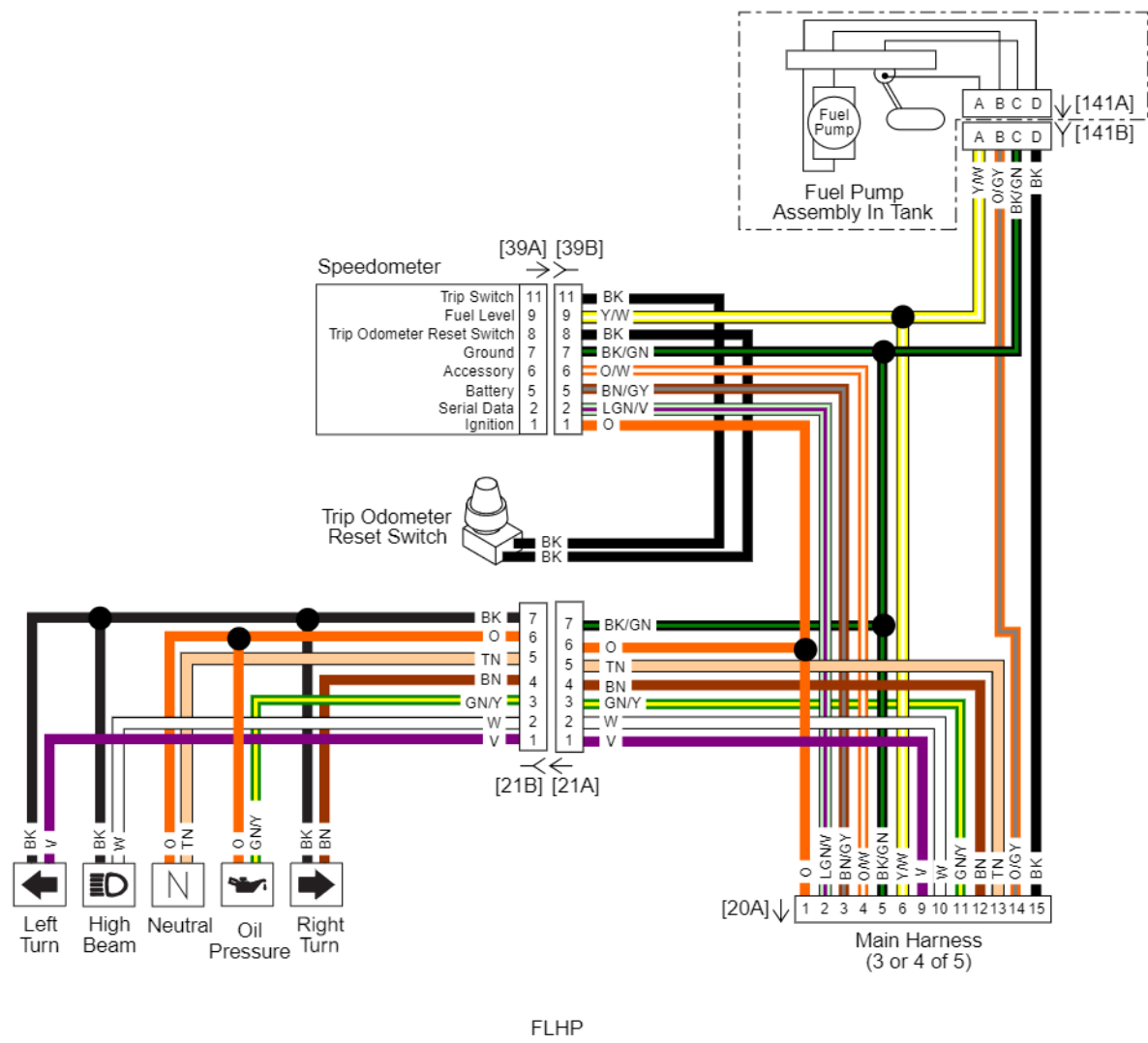

Indicators, Fairing Switch and Handlebar Switches: 2012 FLHTP, FLHP

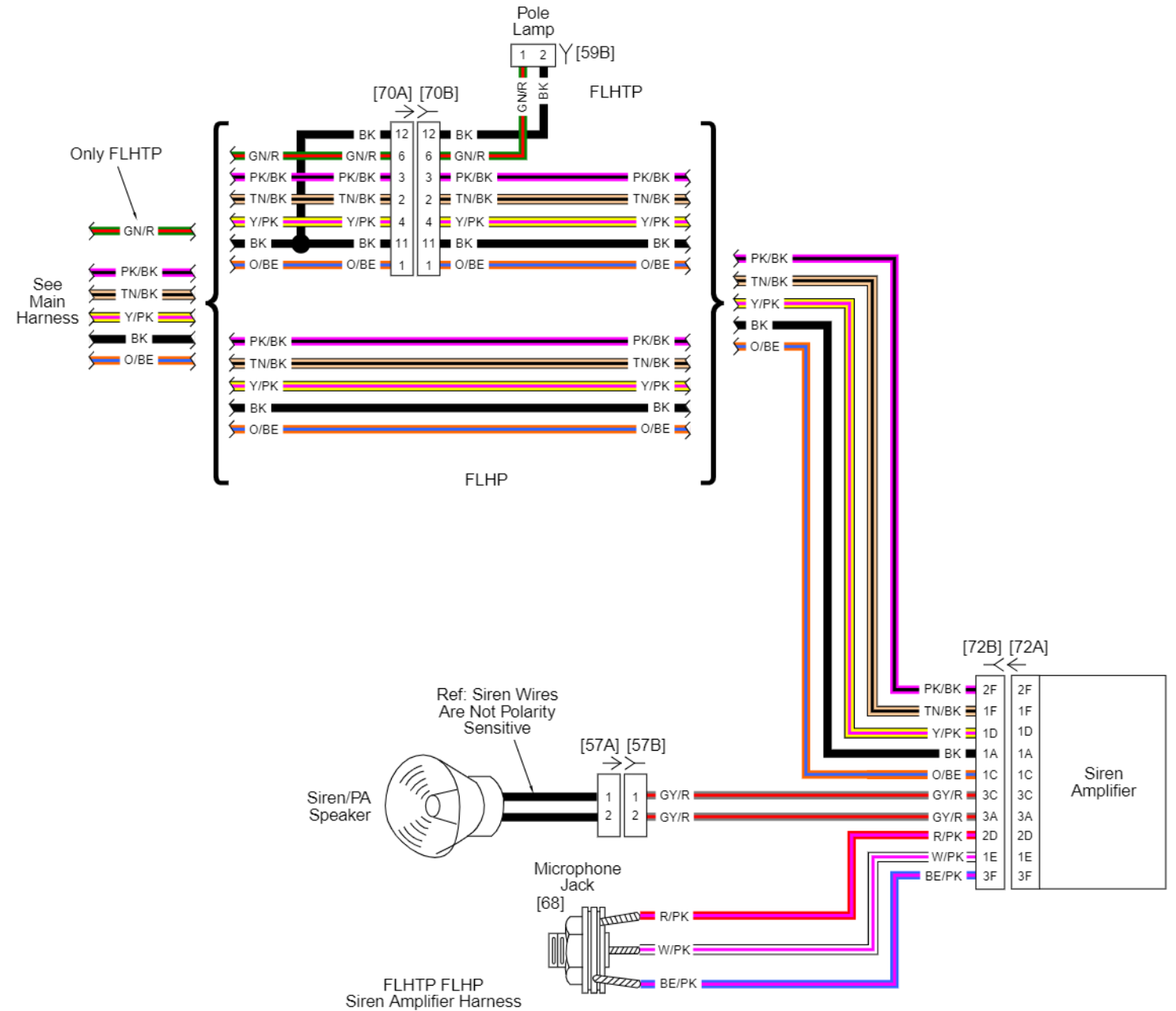
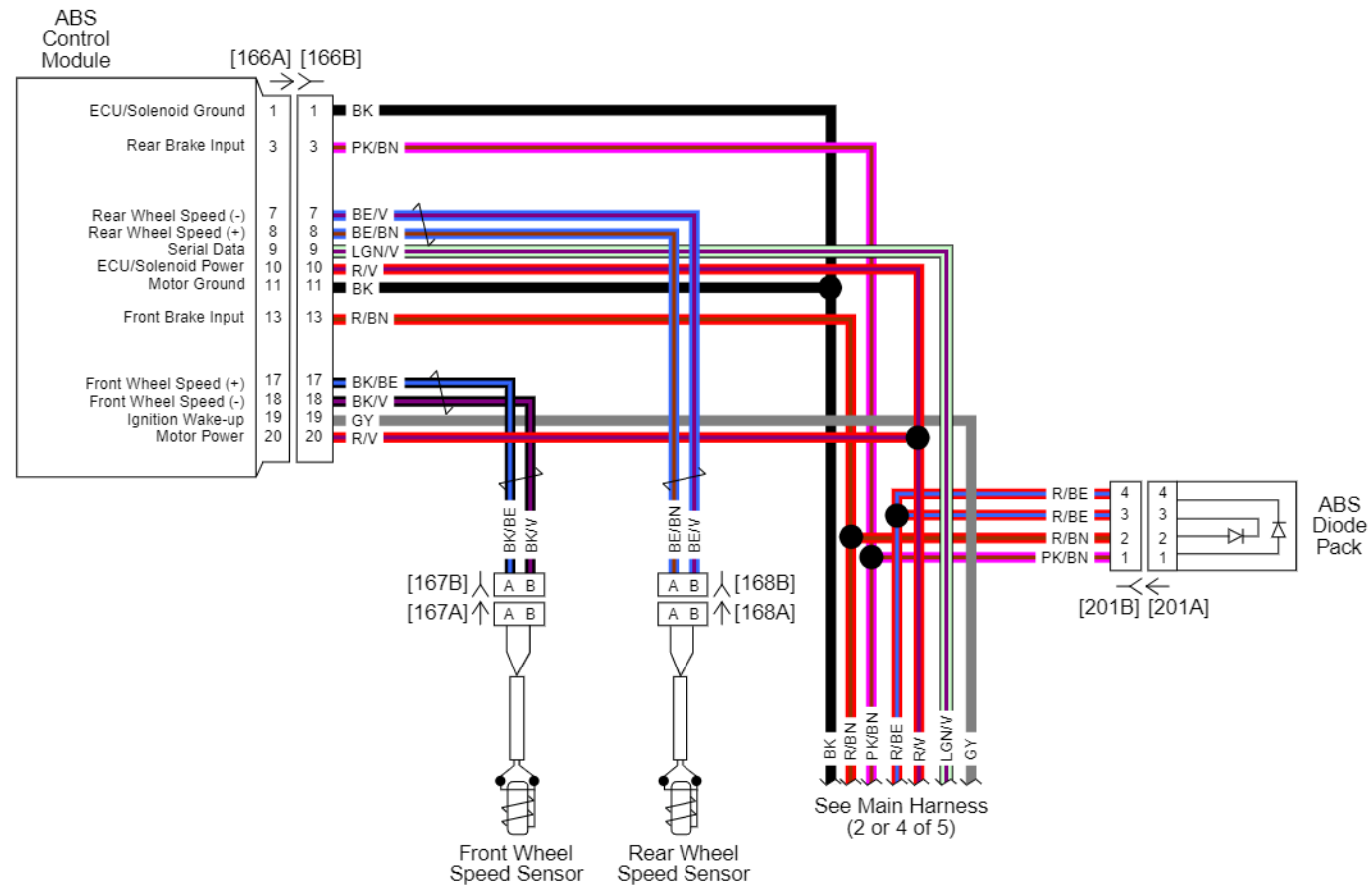

ABS and Siren Amplifier: 2012 FLHTP, FLHP

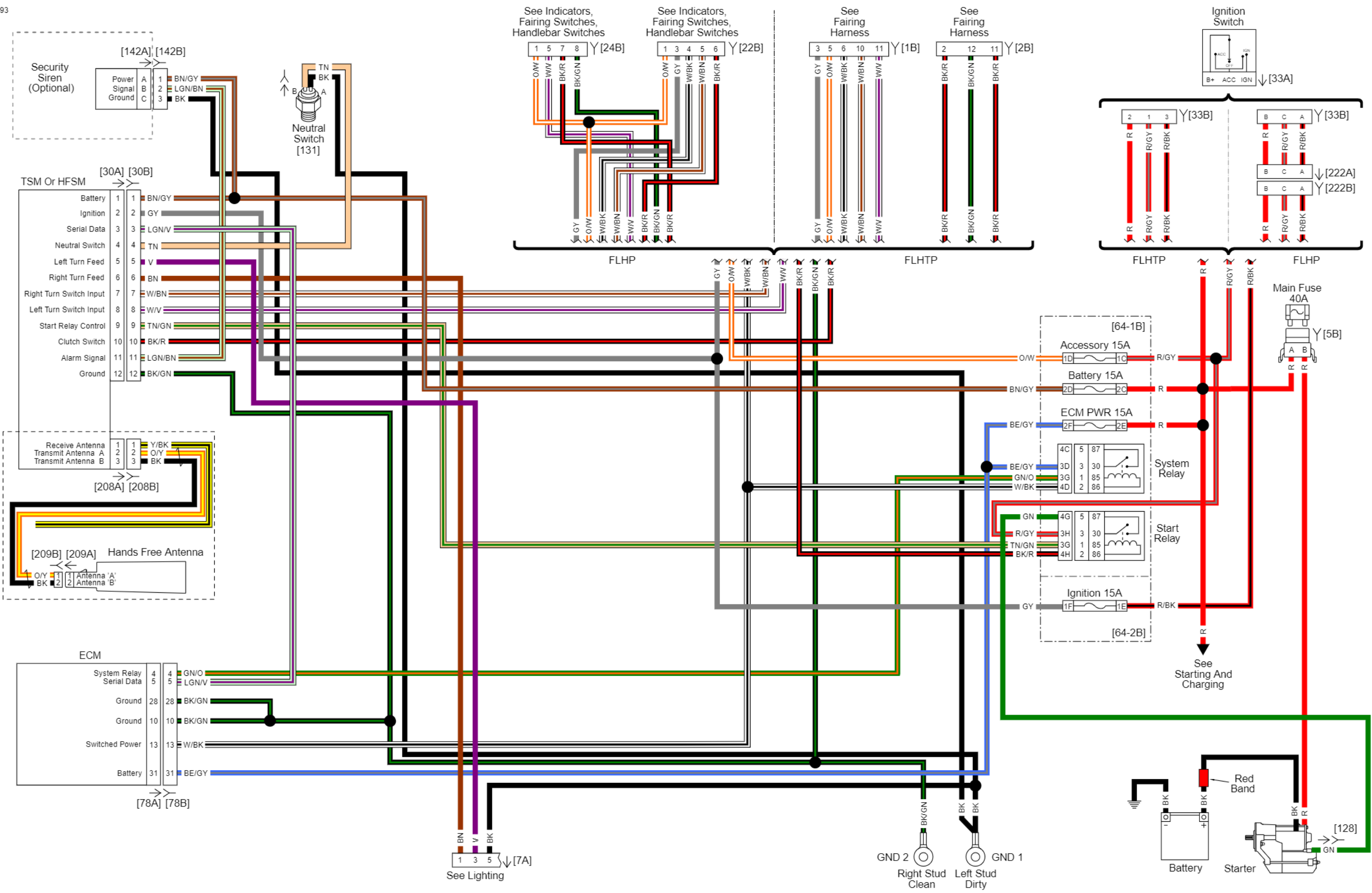

Security Circuit: 2012 FLHTP, FLHP

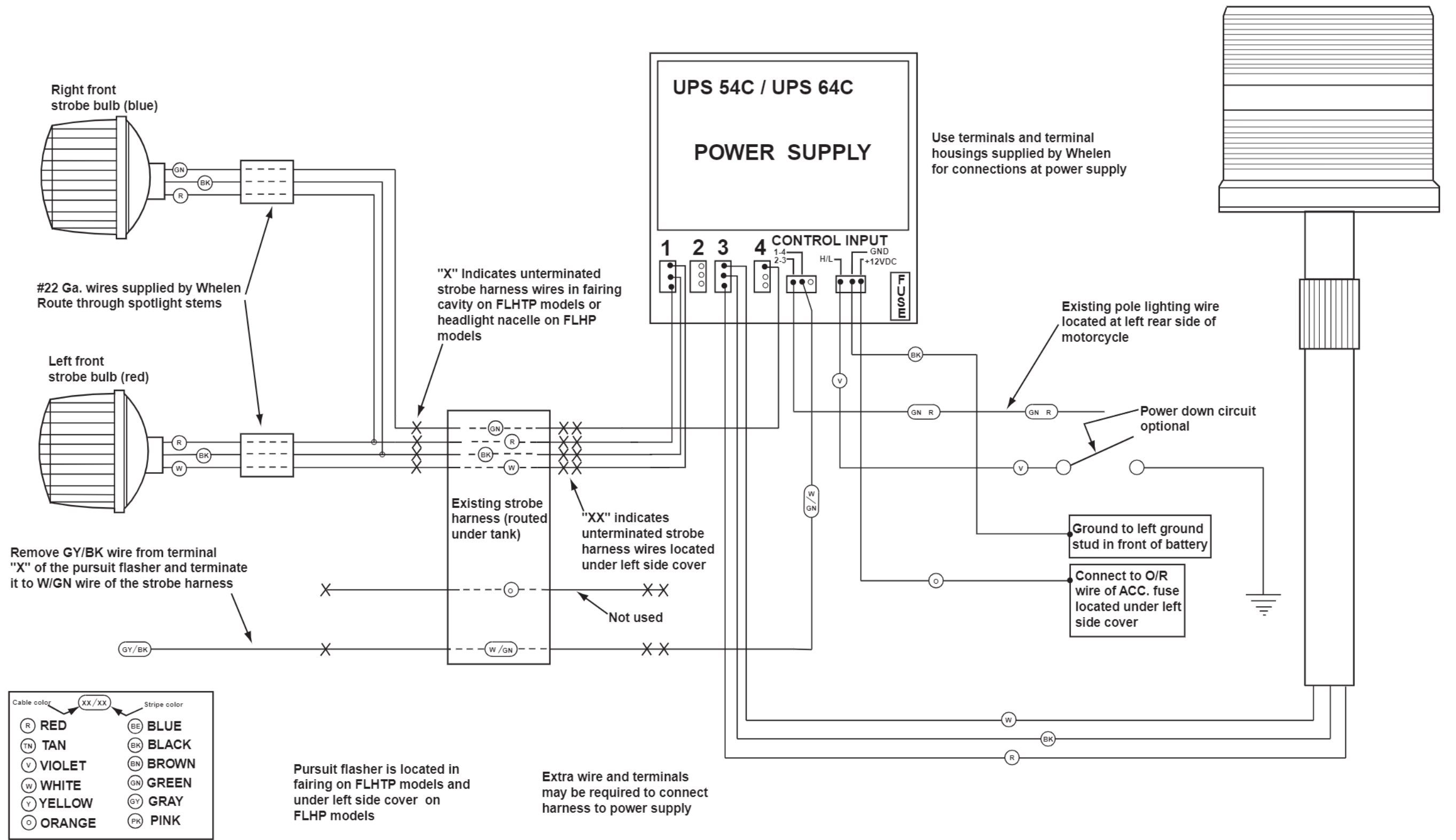

Strobe System: 2012 FLHTP, FLHP

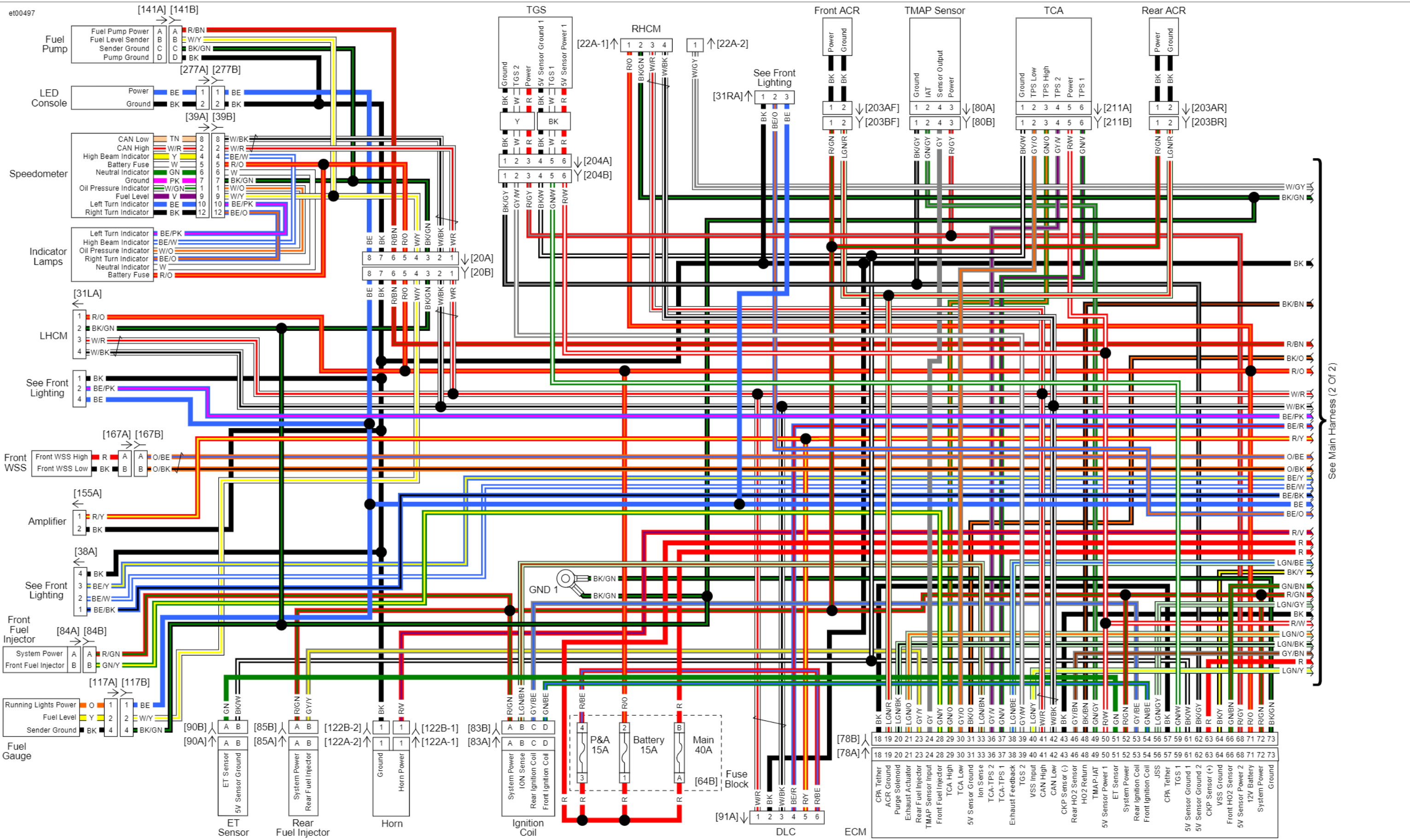

See Main Harness (2 Of 2)

Main Wiring Harness (1 of 2): 2012 FLSTSE3

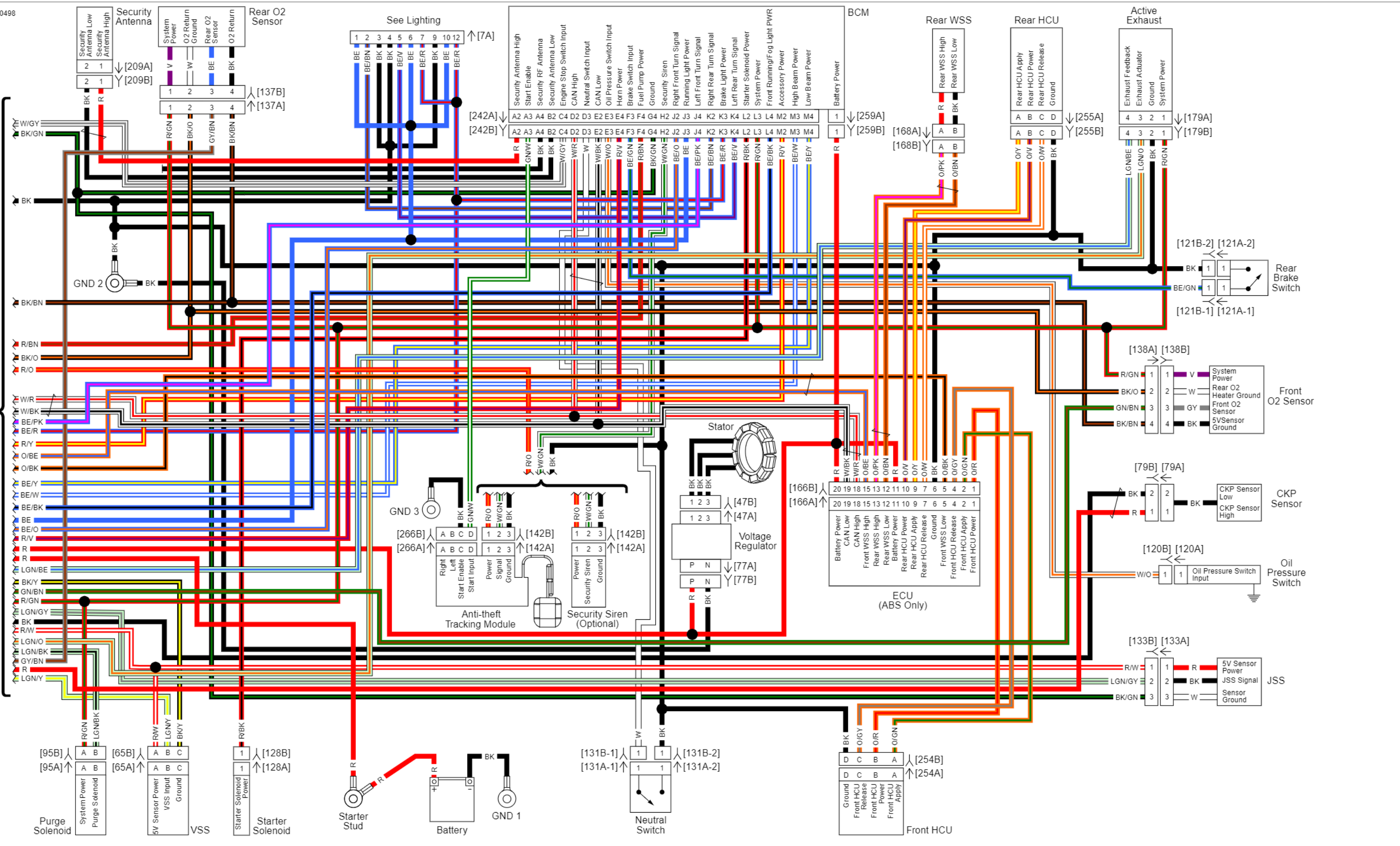

Main Wiring Harness (2 of 2): 2012 FLSTSE3

Front Lighting

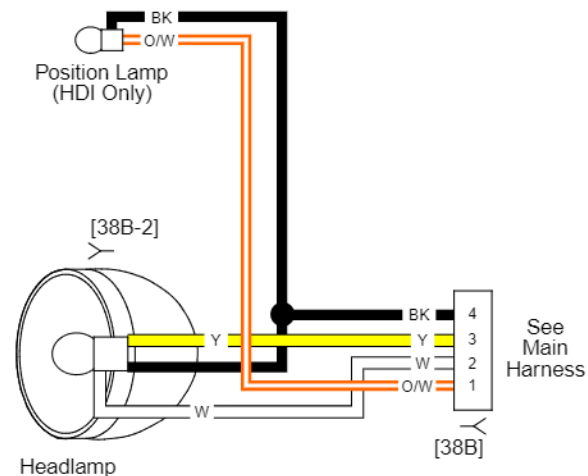

Rear Lighting

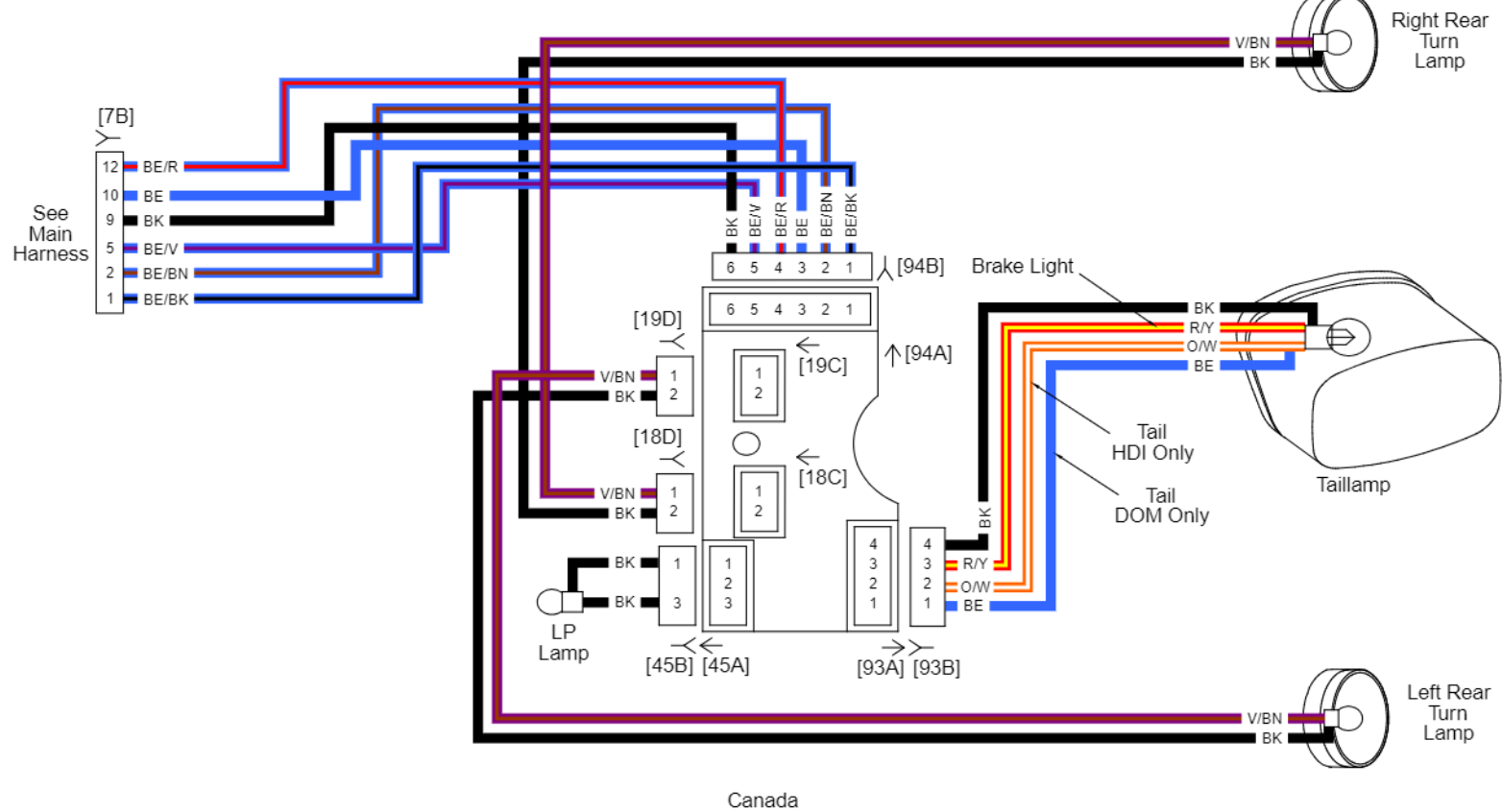

Front Turn Signals With Turn Bar

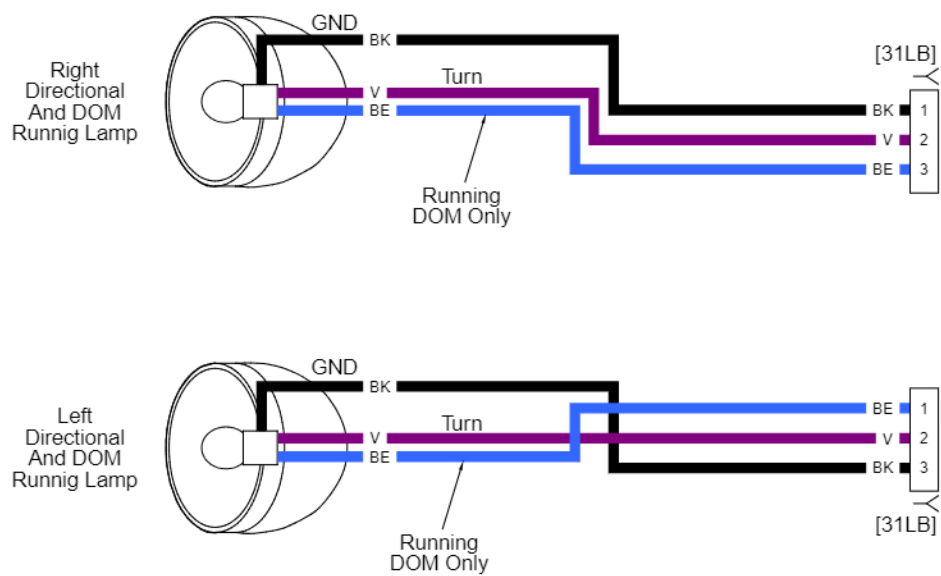

HDI

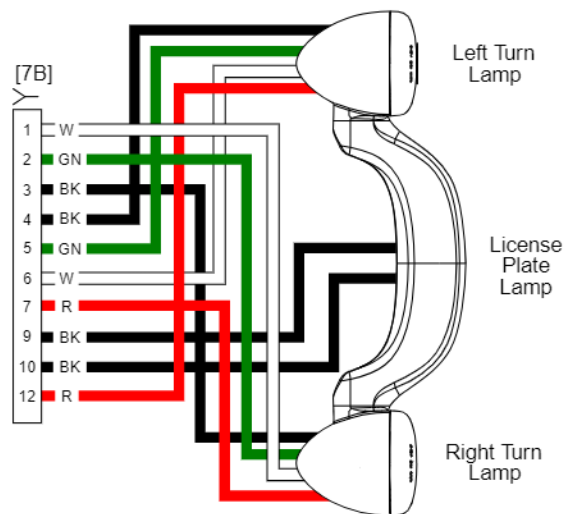

Domestic

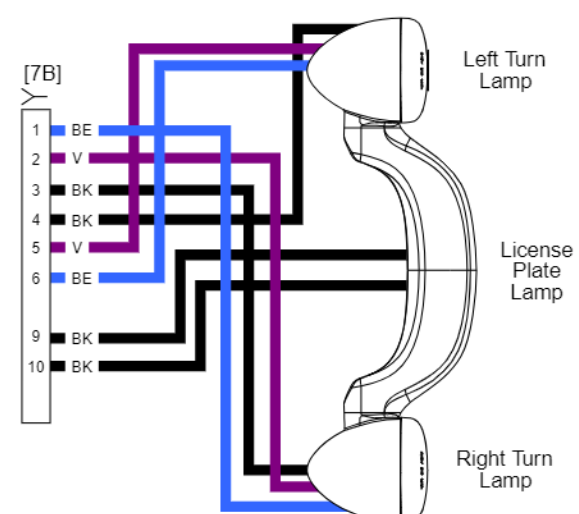

Lighting: 2012 FLSTSE3

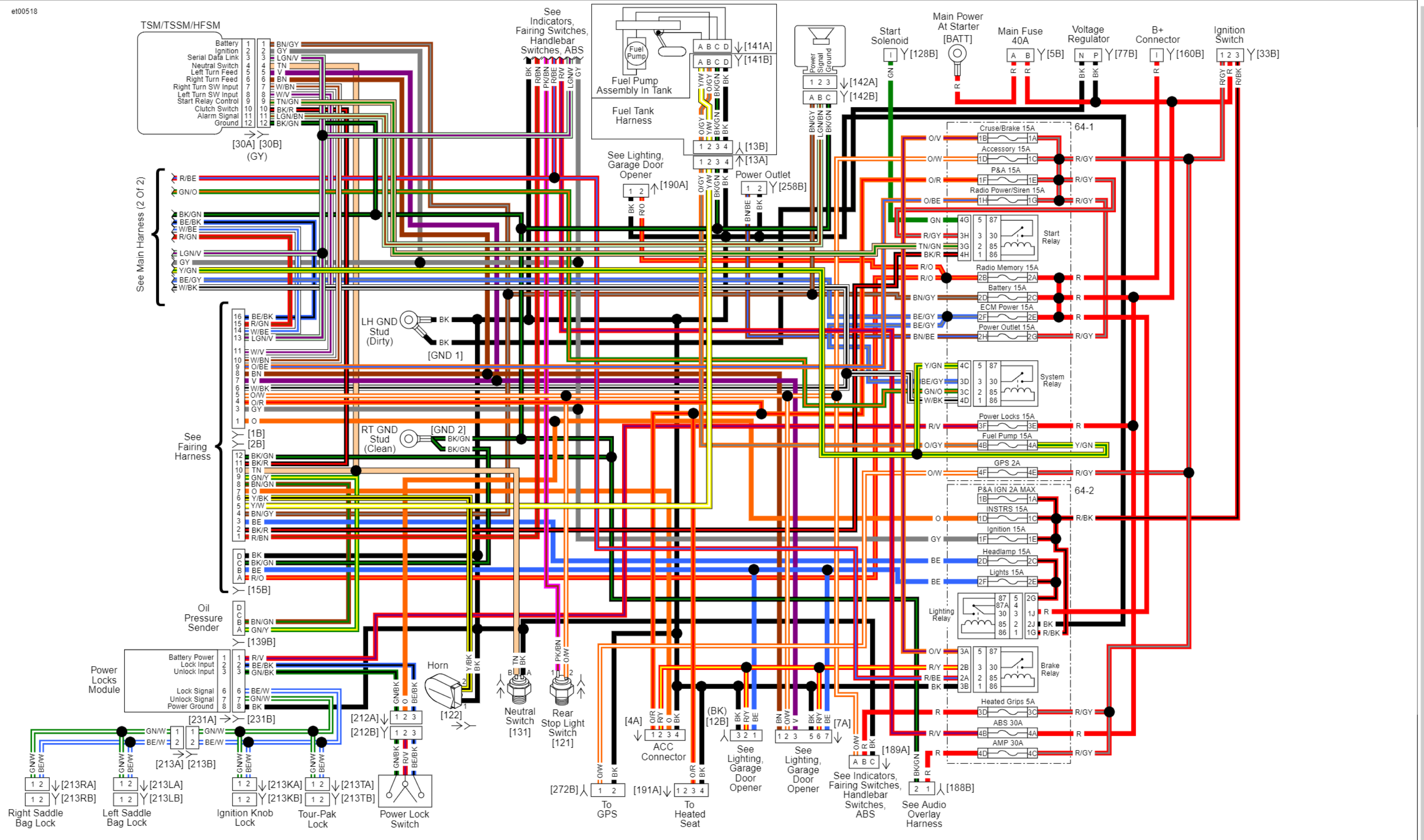

Main Harness (1 of 2): 2012 FLHTCUSE7

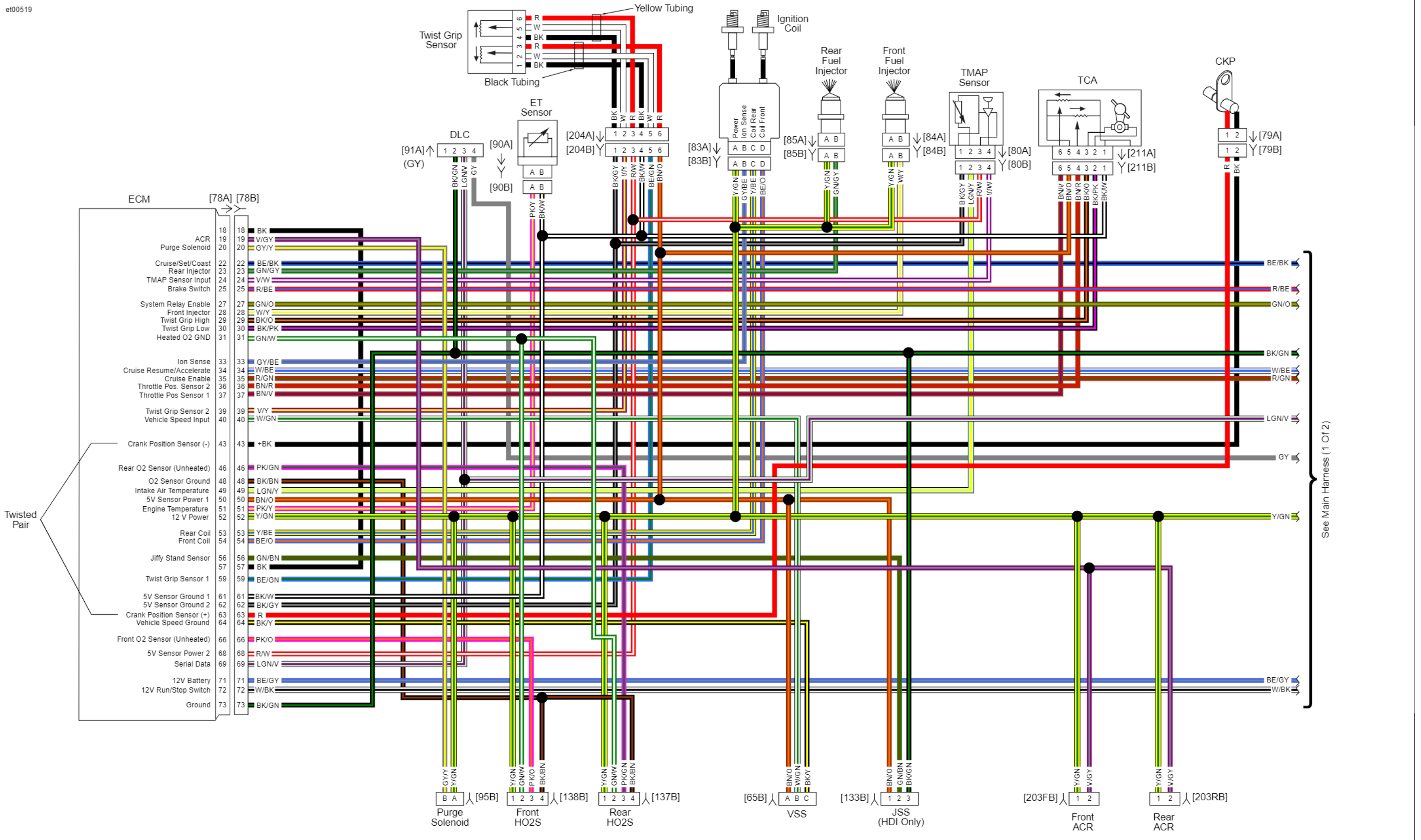

Main Harness (2 of 2): 2012 FLHTCUSE7

See Main Harness (1 Of 2)

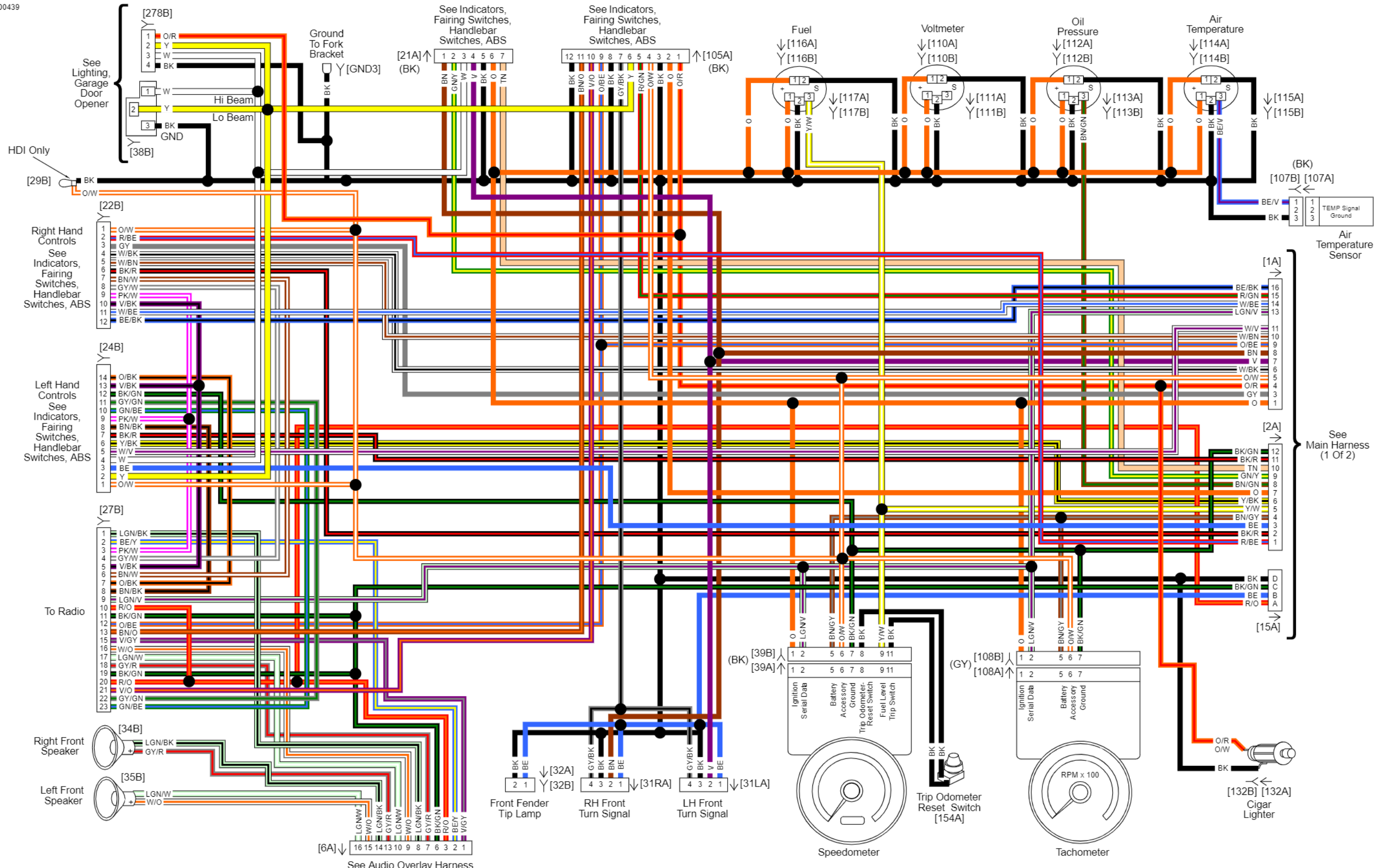

Fairing Harness: 2012 FLHTCUSE7

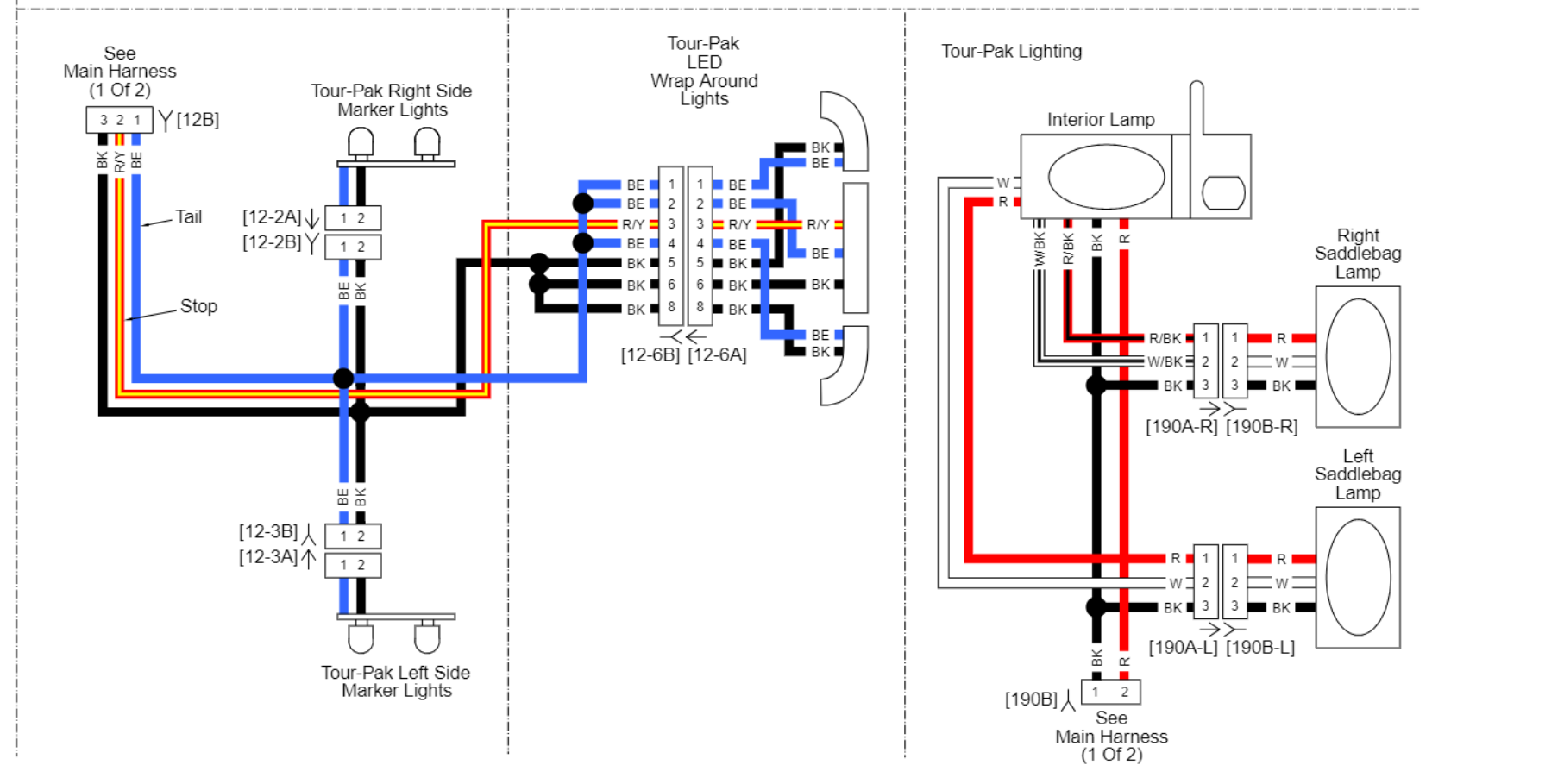
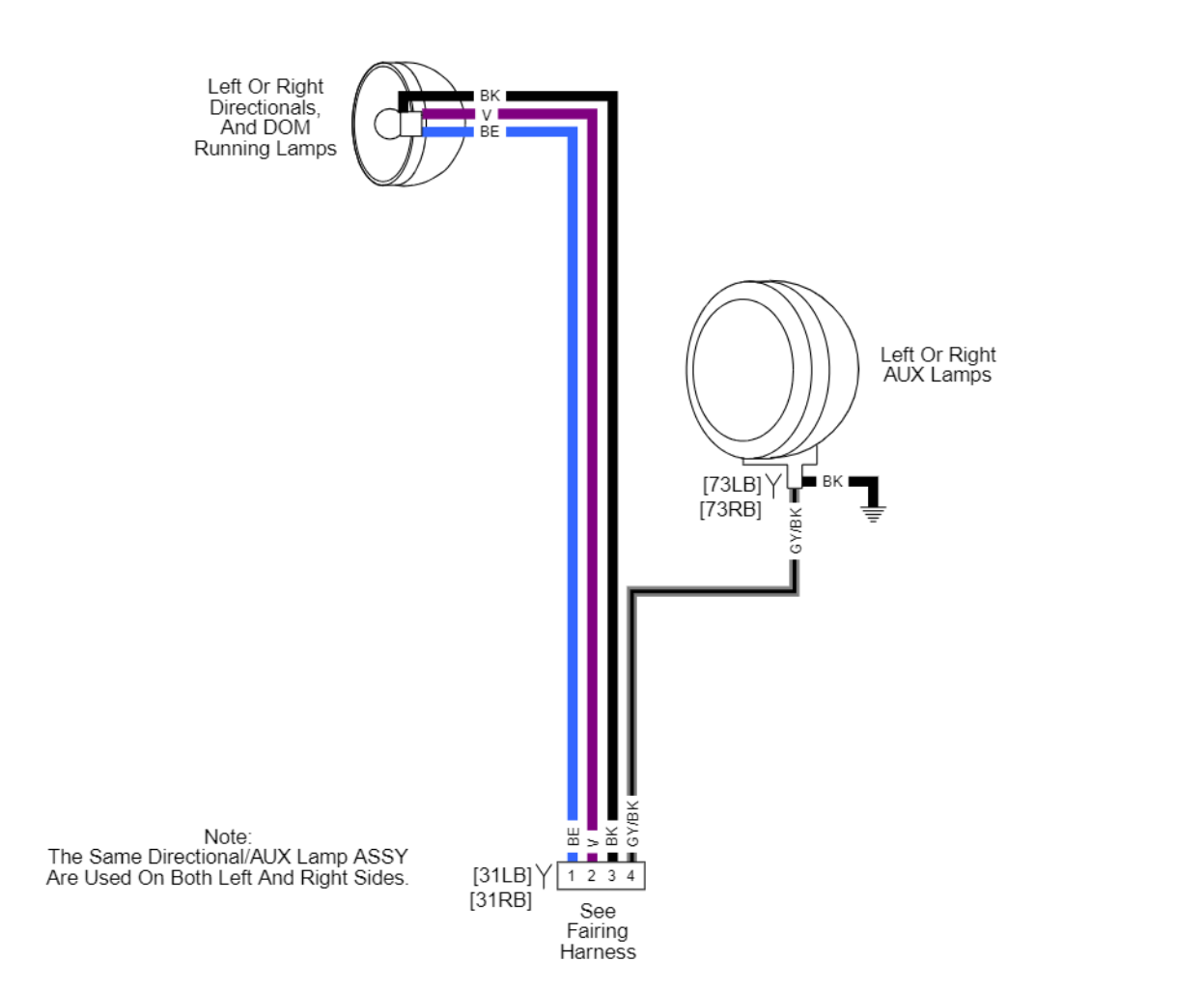
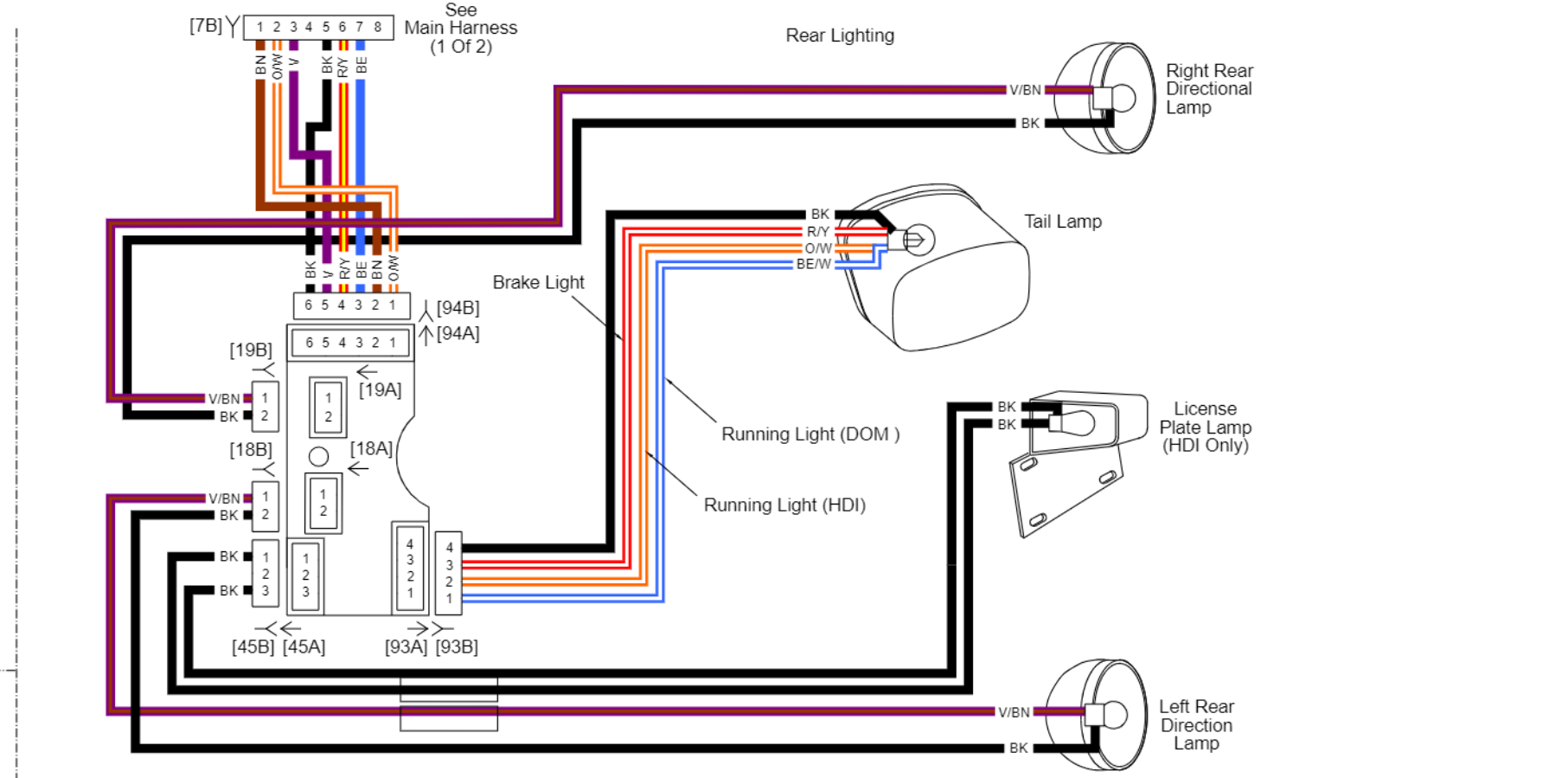
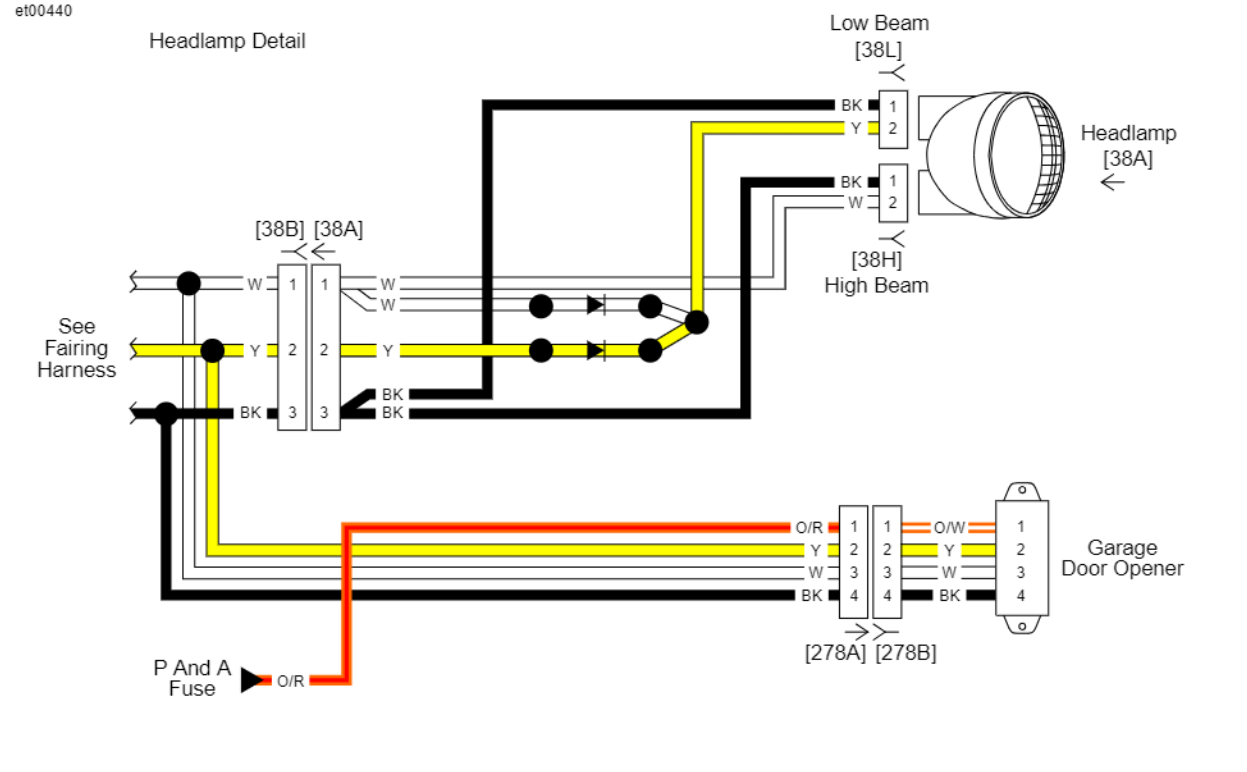

Lighting, Garage Door Opener: 2012 FLHTCUSE7

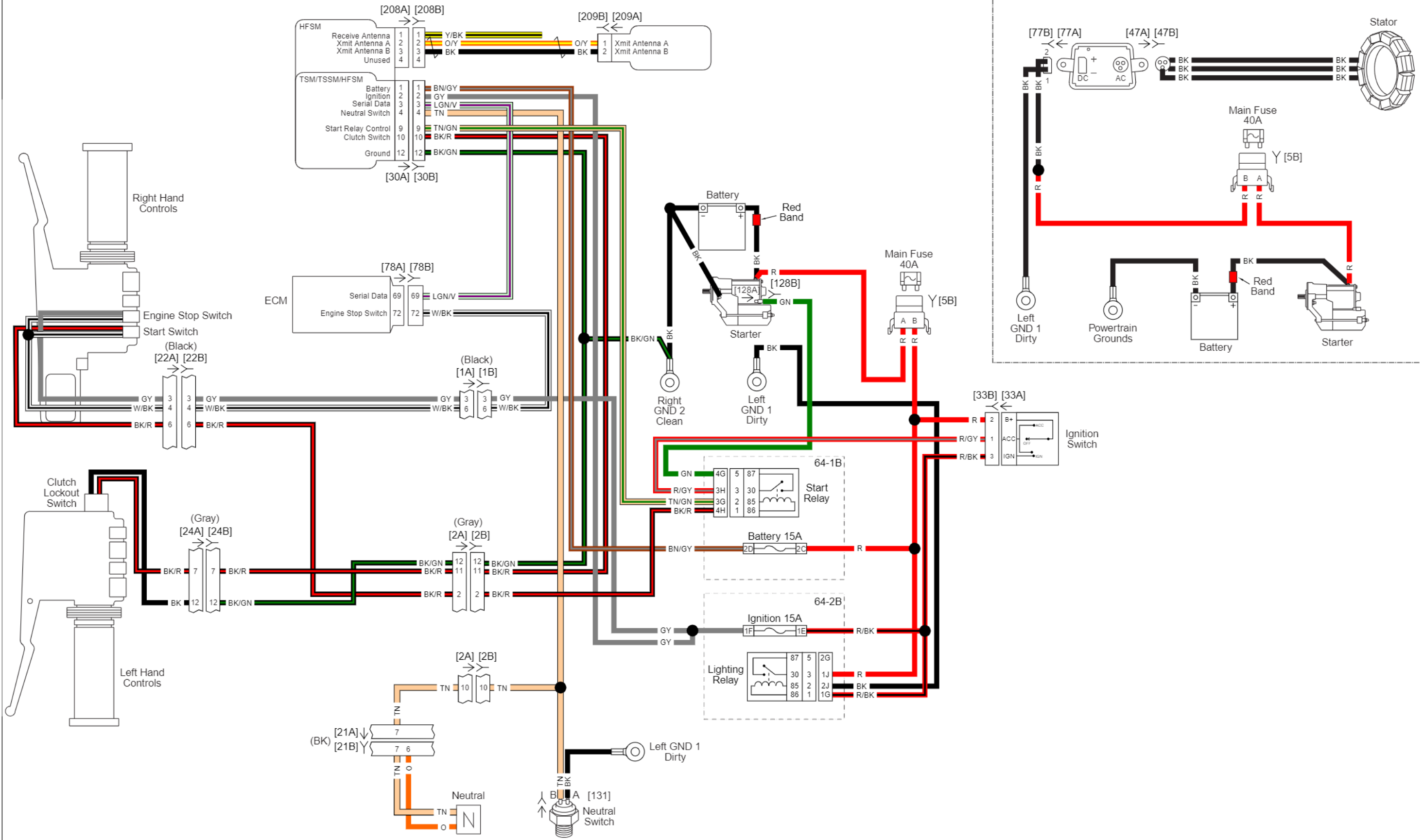

Starting and Charging System: 2012 FLHTCUSE7

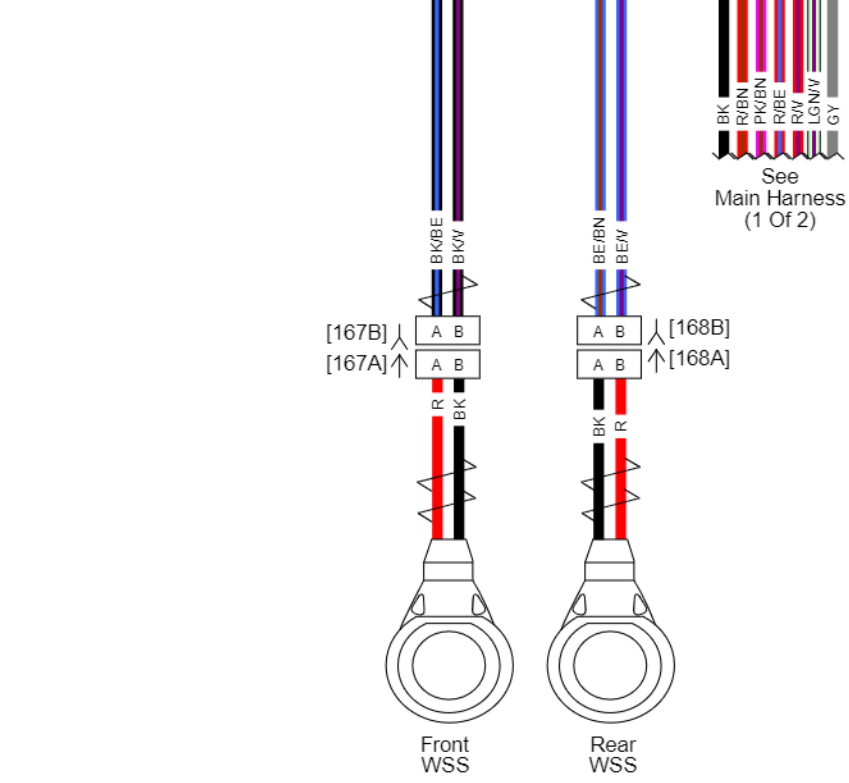
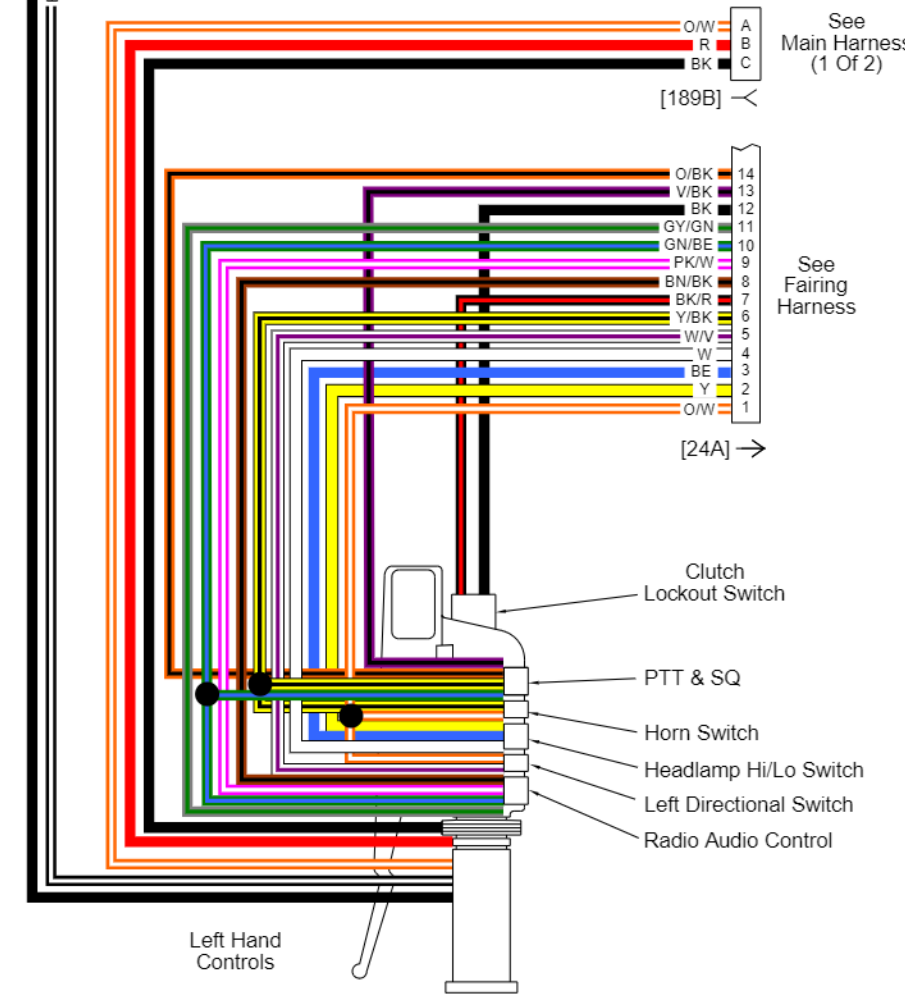
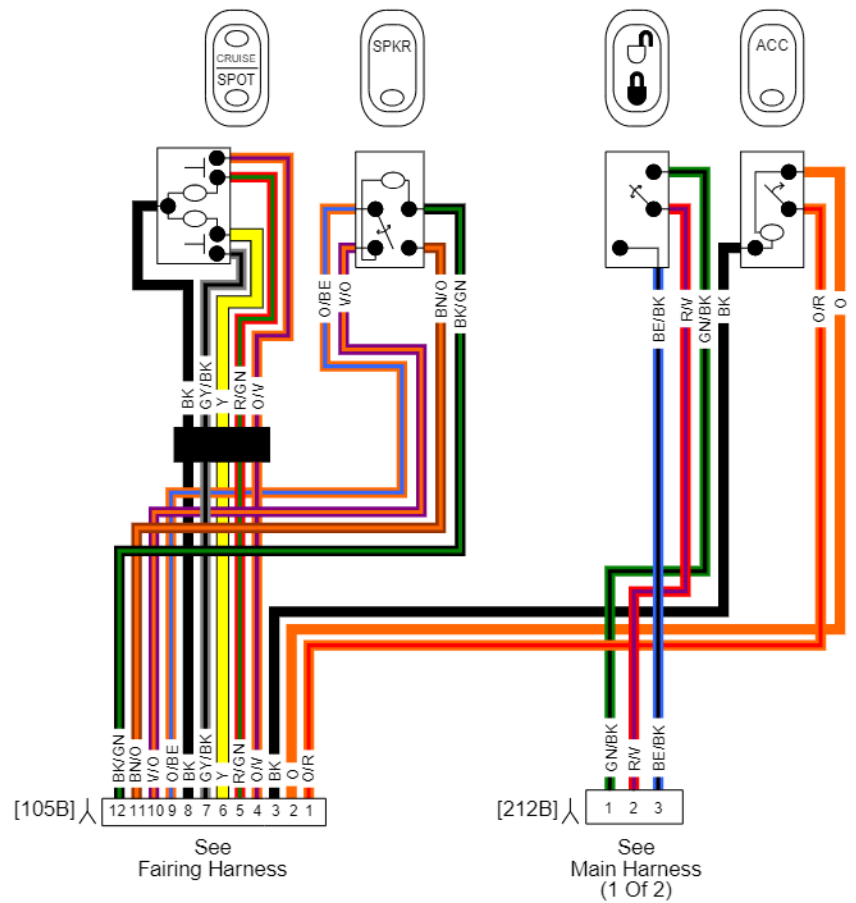
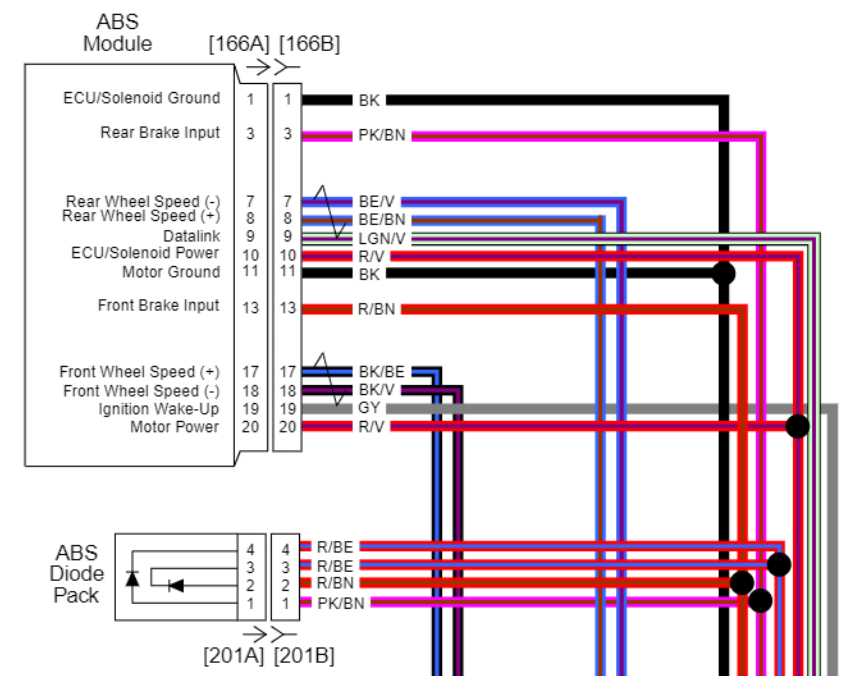
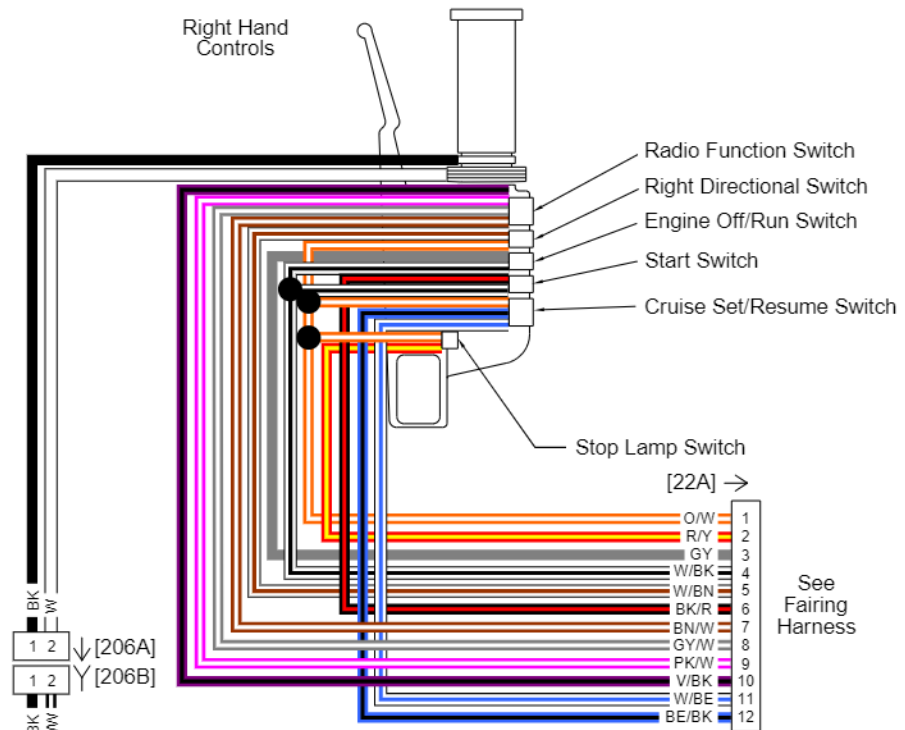
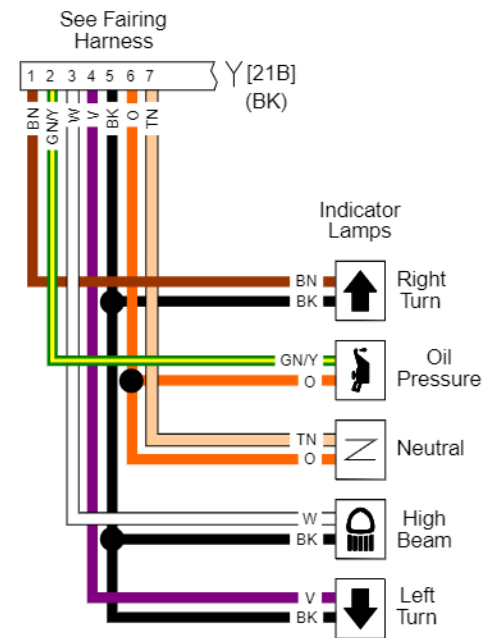

Indicators, Fairing Switches, Handlebar Switches, ABS: 2012 FLHTCUSE7

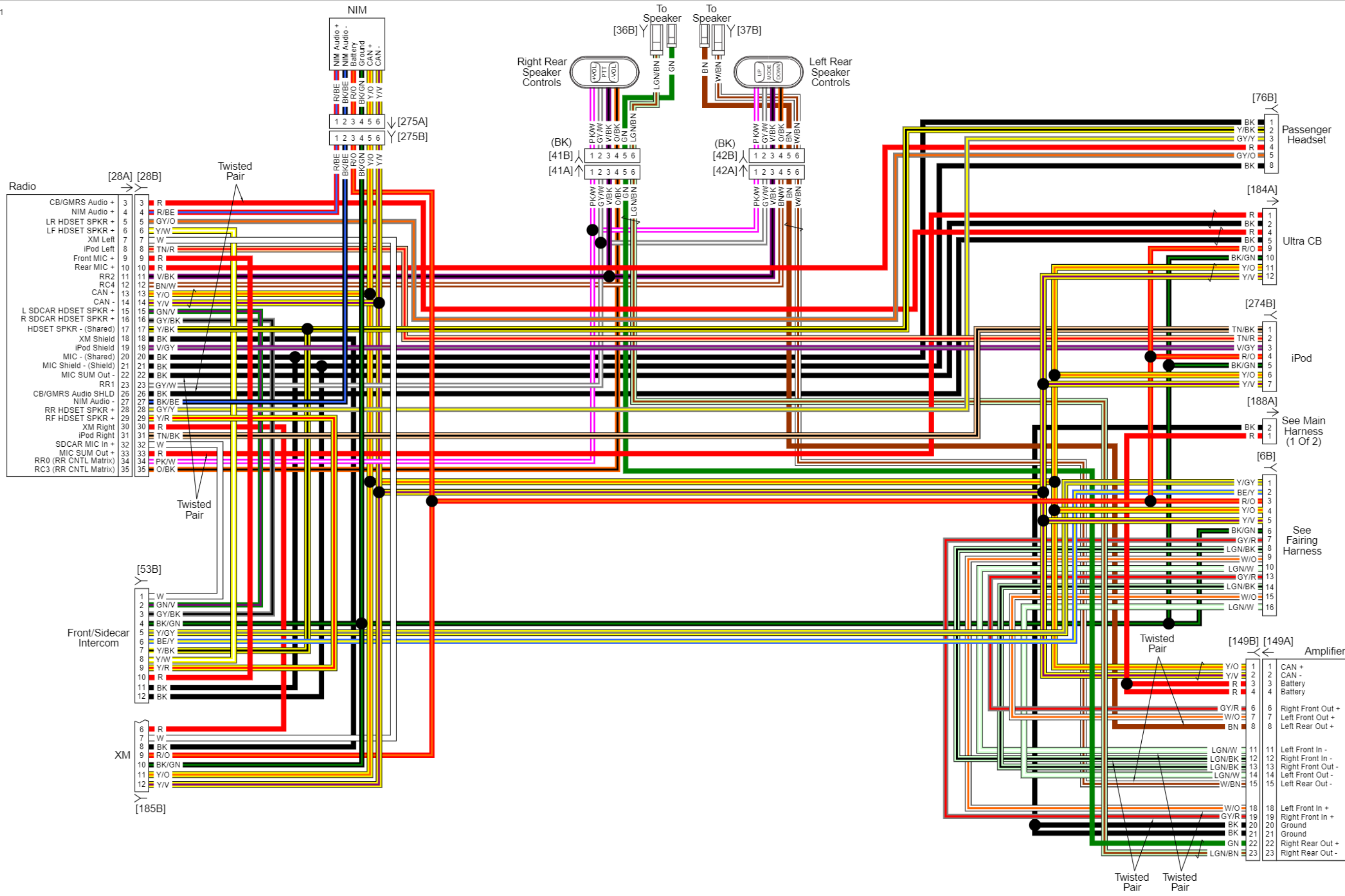

Audio Overlay Harness: 2012 FLHTCUSE7

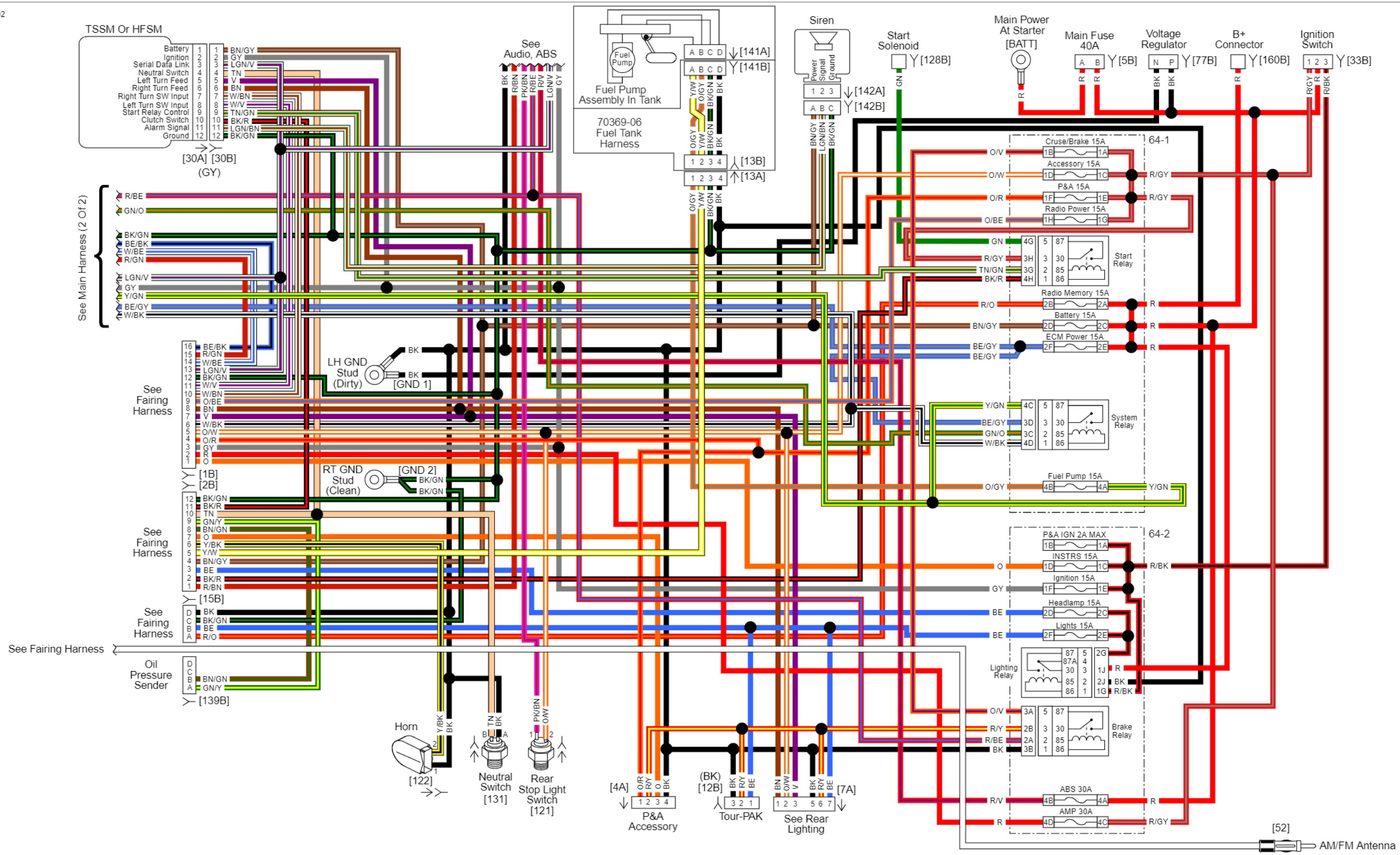

Main Harness (1 of 2): 2012 FLTRXSE

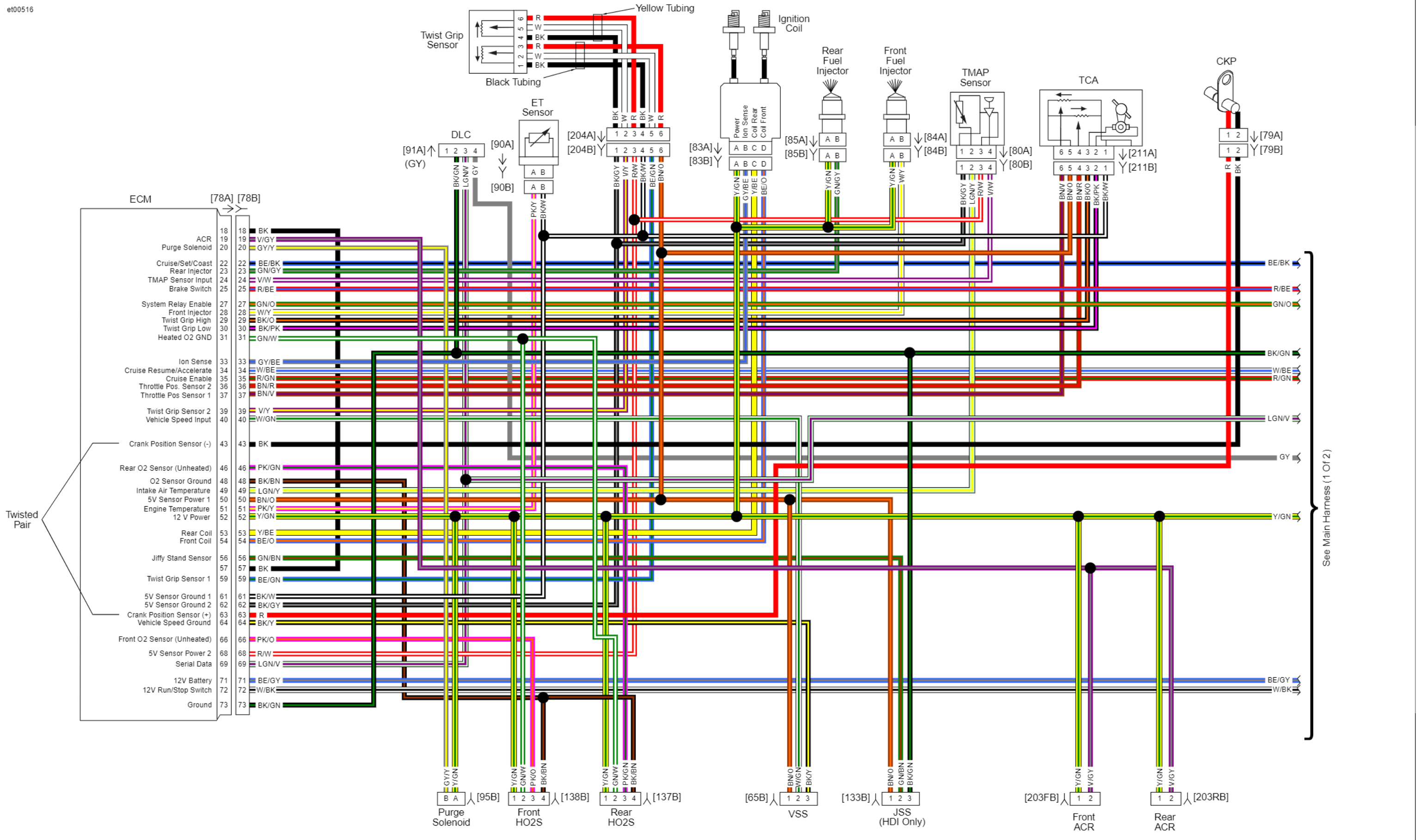

Main Harness (2 of 2): 2012 FLTRXSE

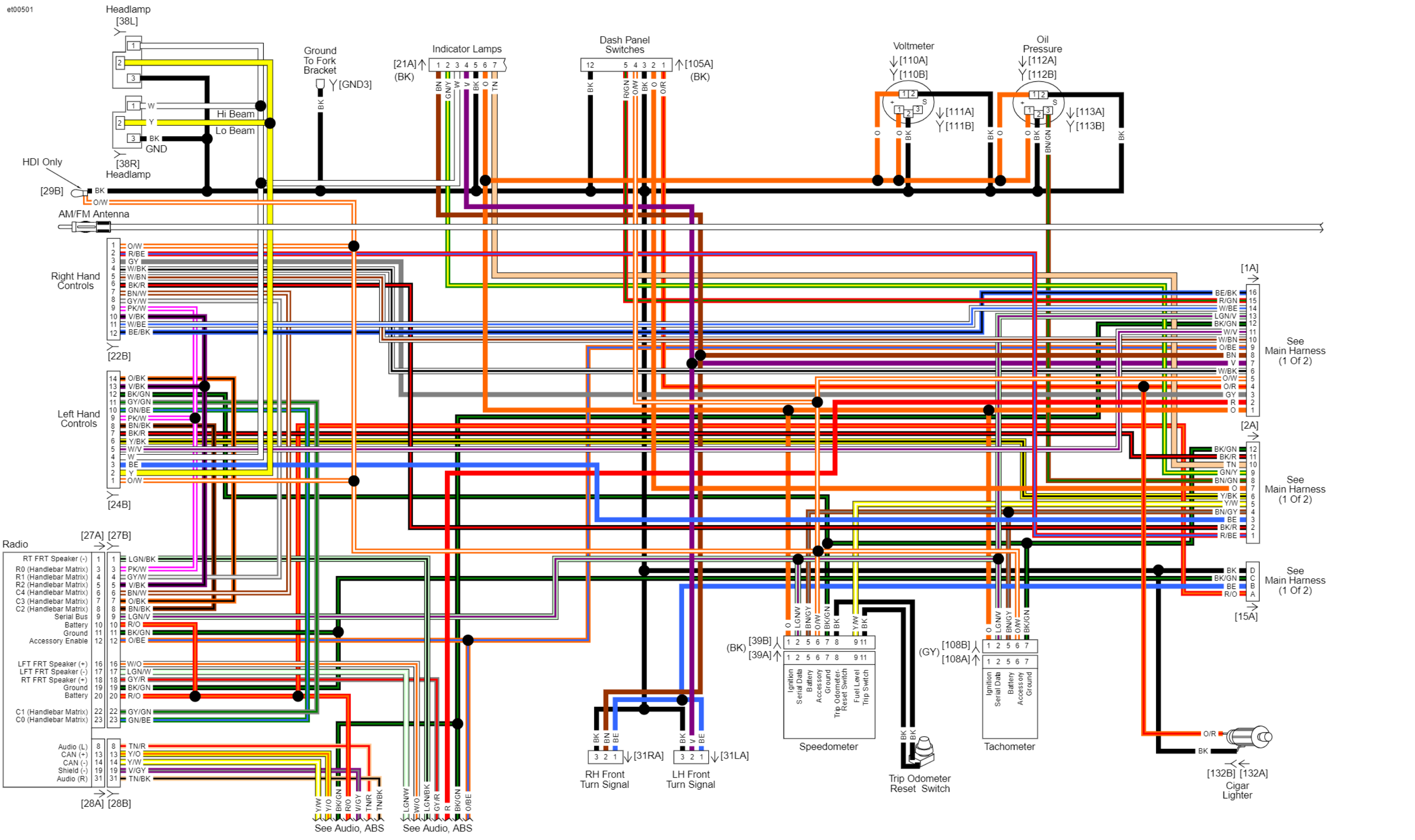

Fairing Harness: 2012 FLTRXSE

Domestic

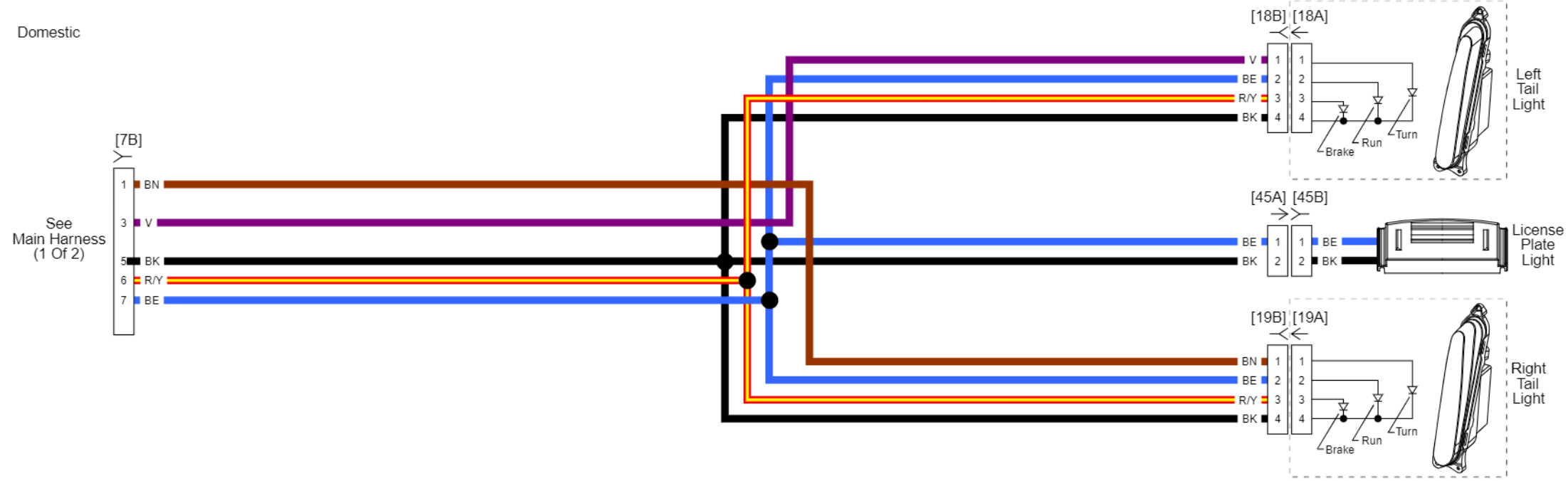

HDI

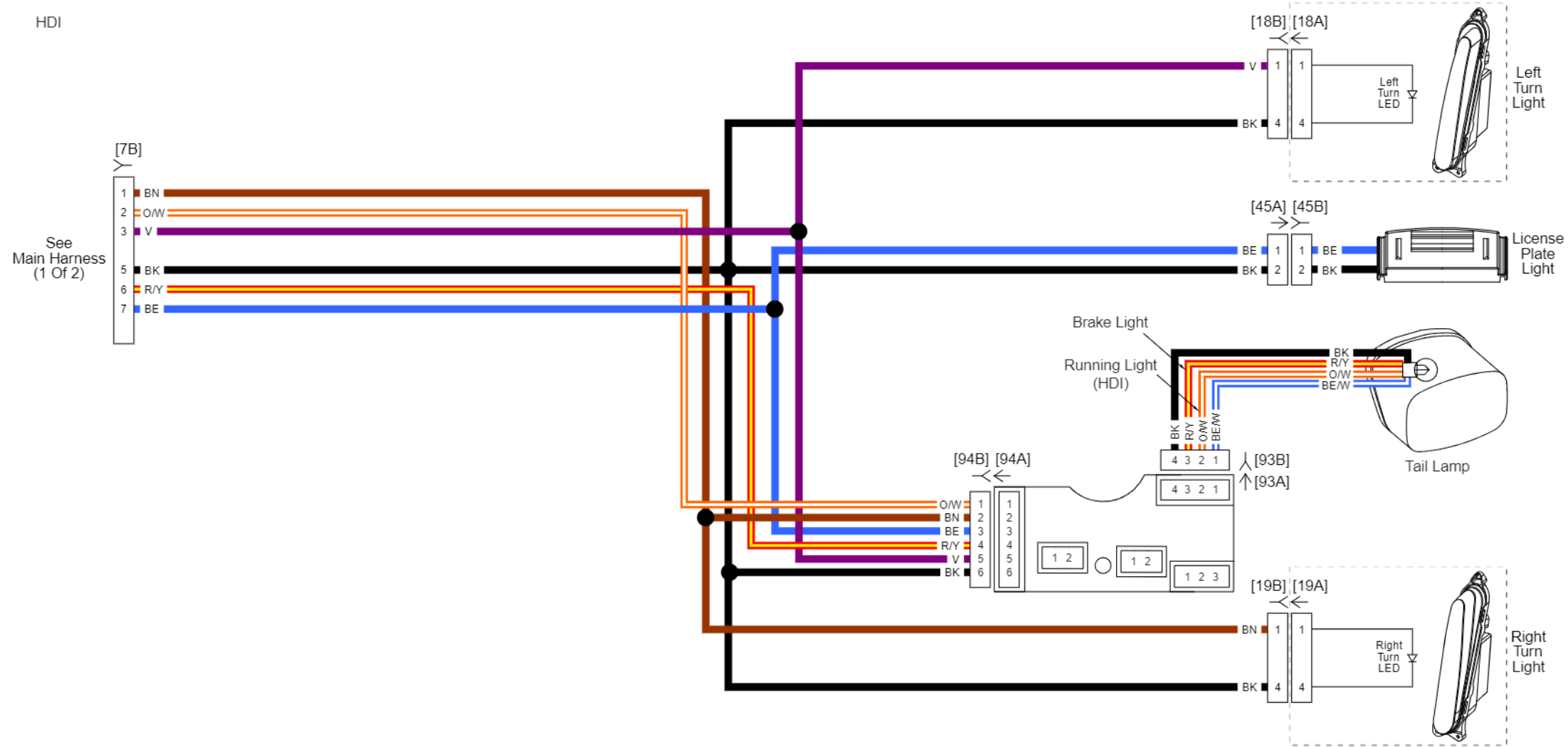

Rear Lighting: 2012 FLTRXSE

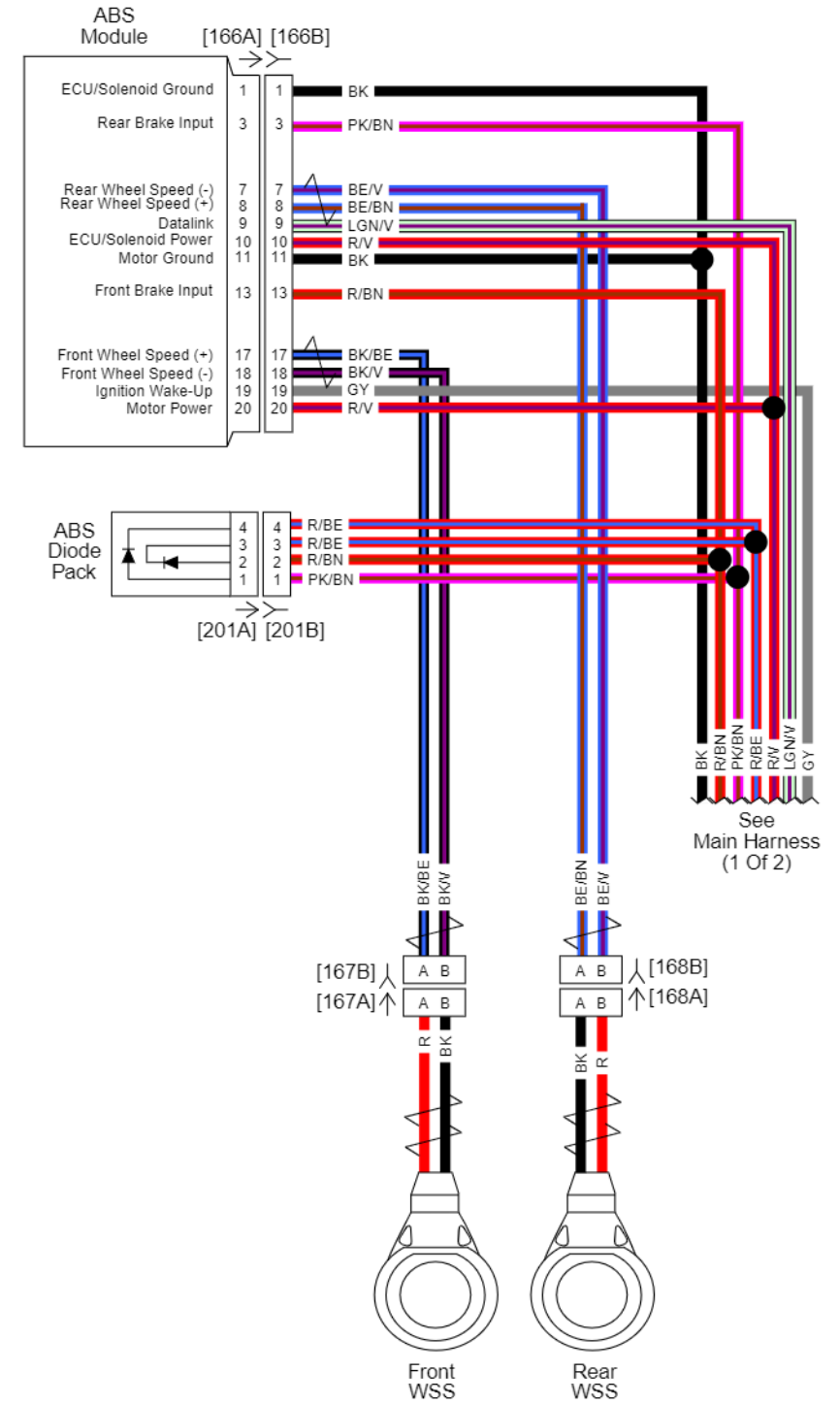
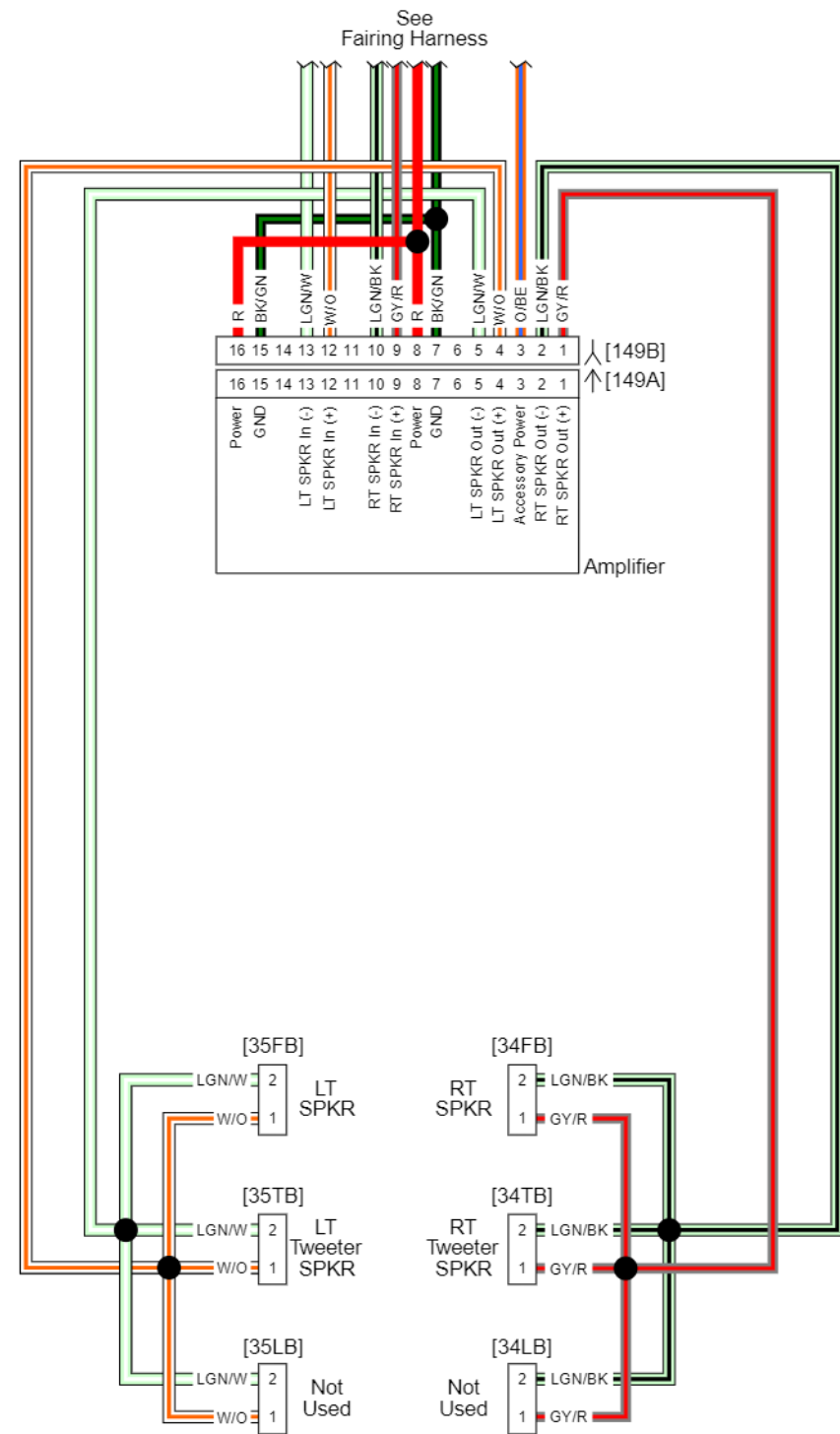
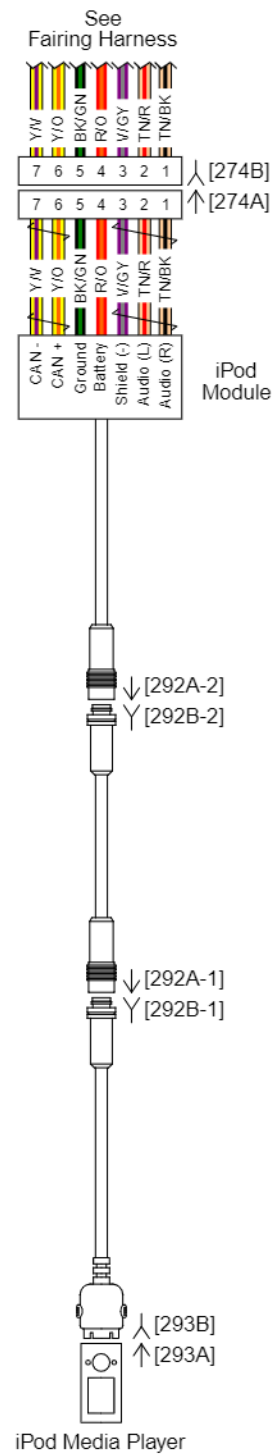

Audio, ABS: 2012 FLTRXSE

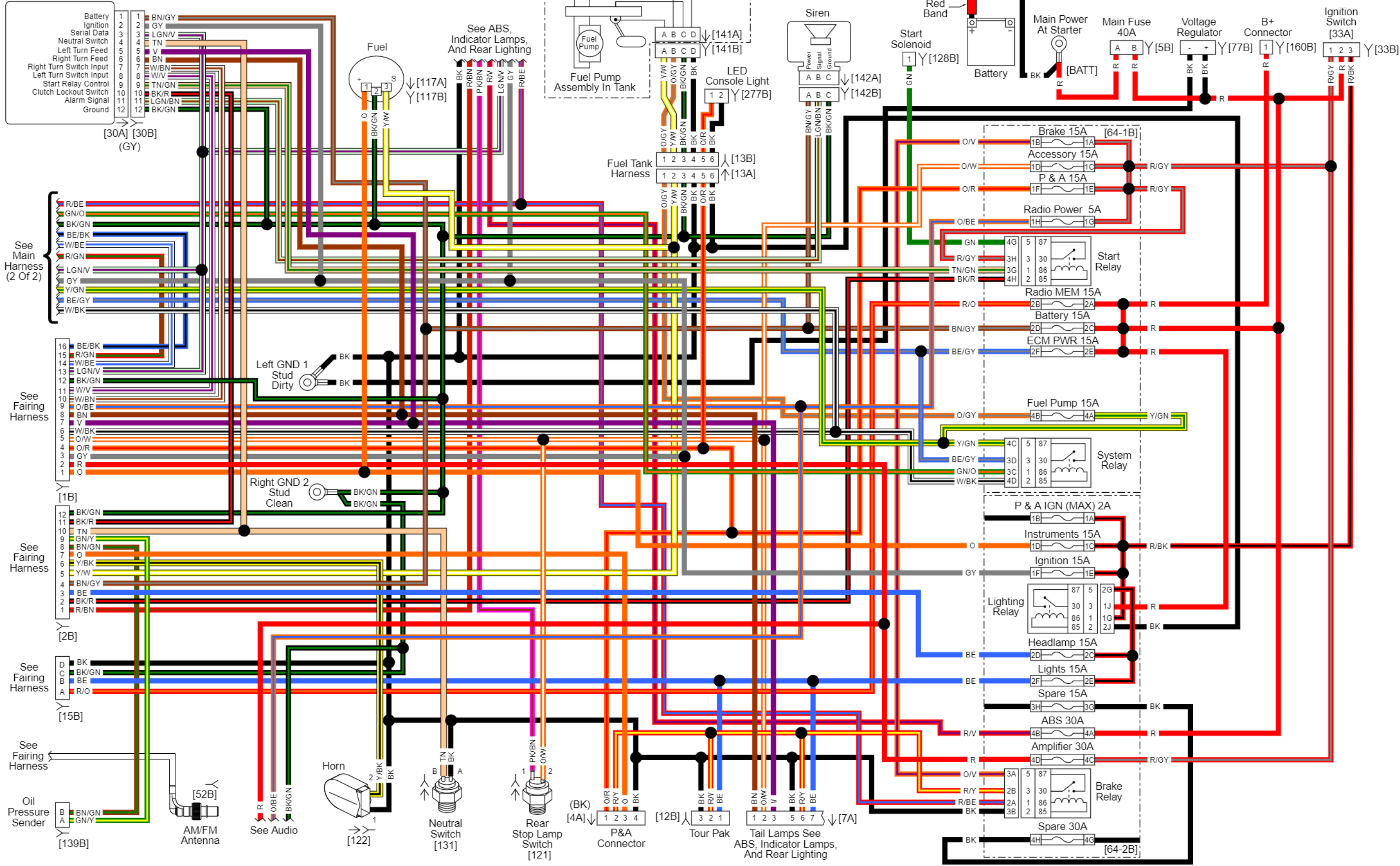

Main Wiring Harness (1 of 2): 2012 FLHXSE3

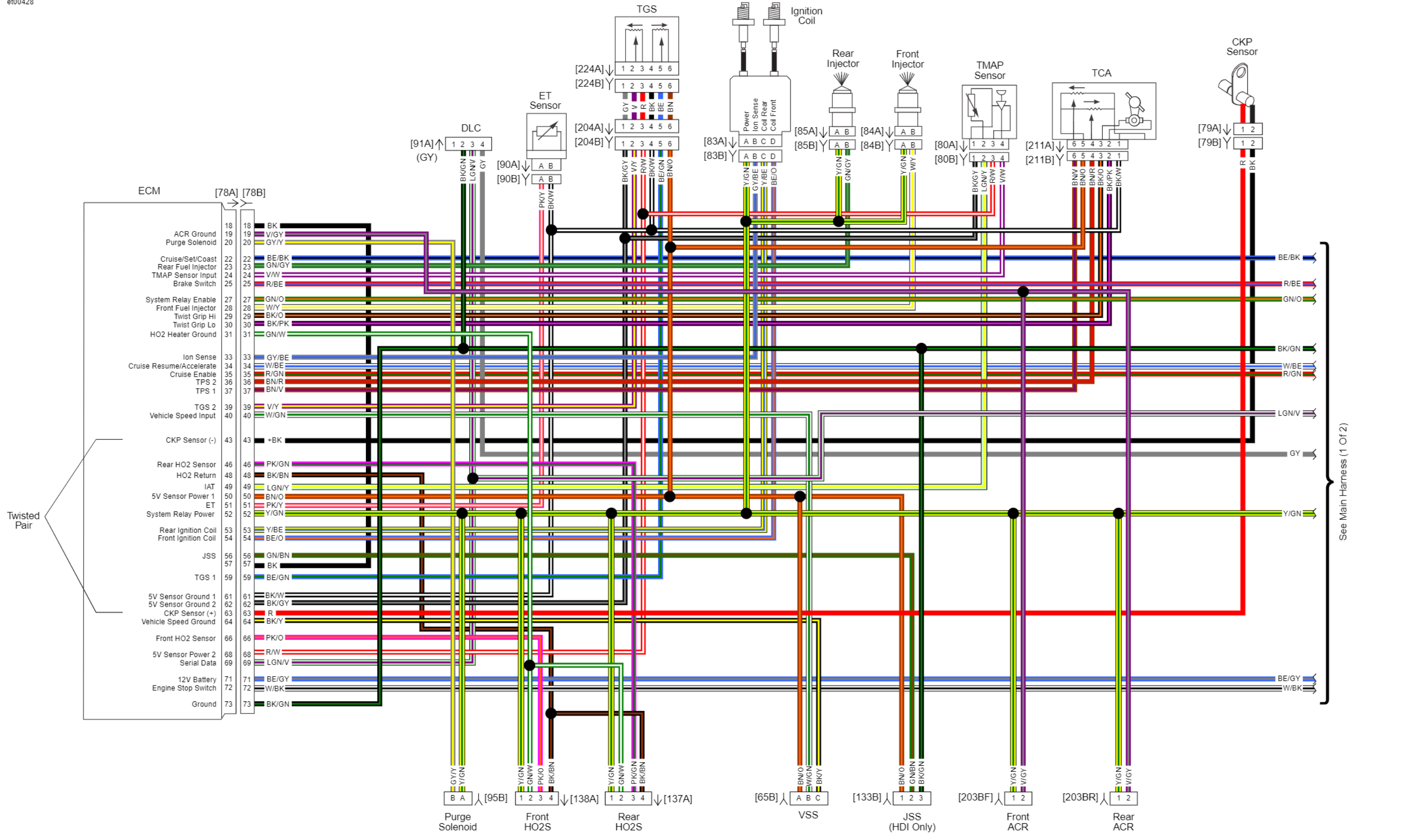

Main Wiring Harness (2 of 2): 2012 FLHXSE3

See Main Harness (1 Of 2)

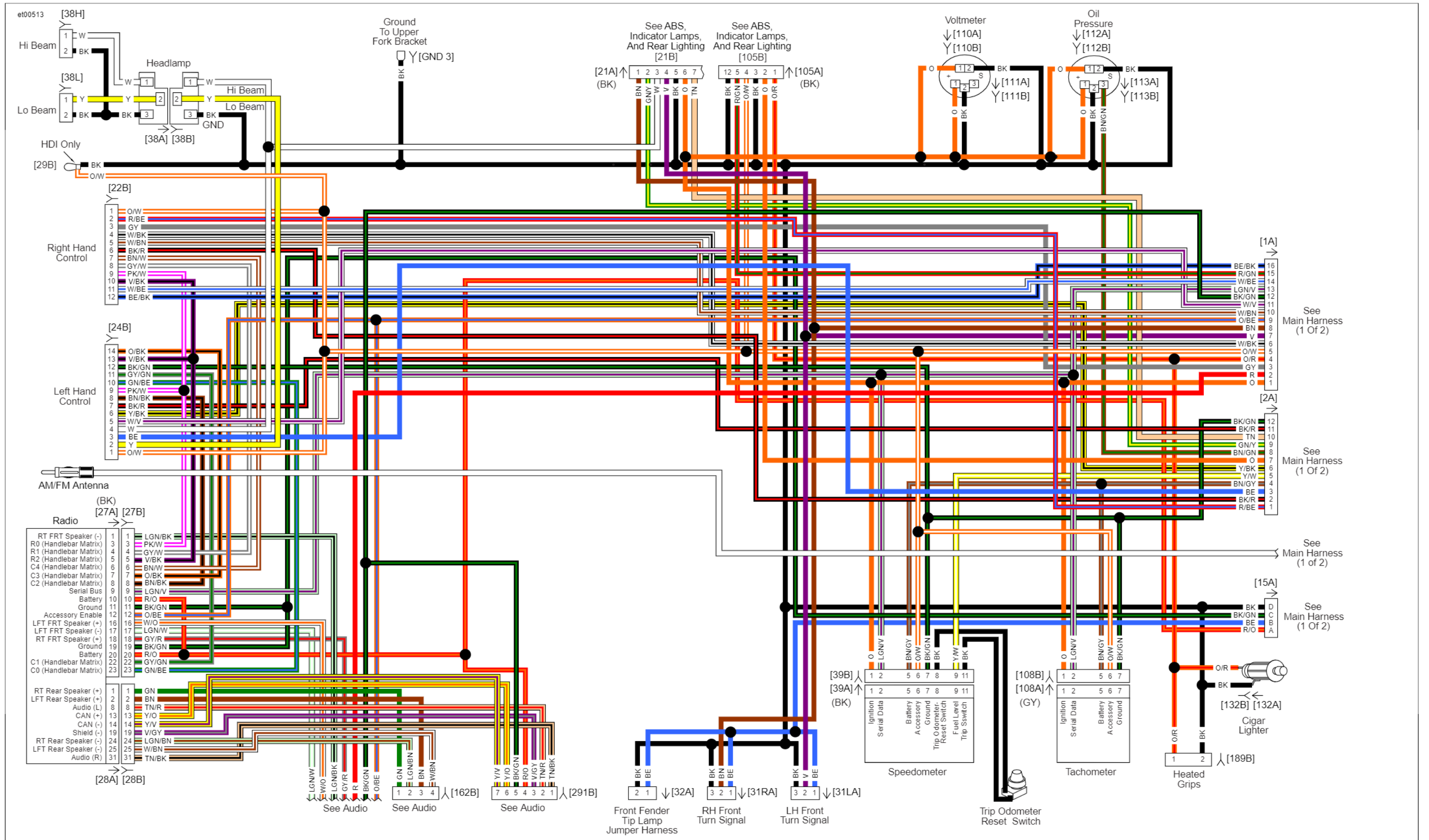

Fairing Harness: 2012 FLHXSE3

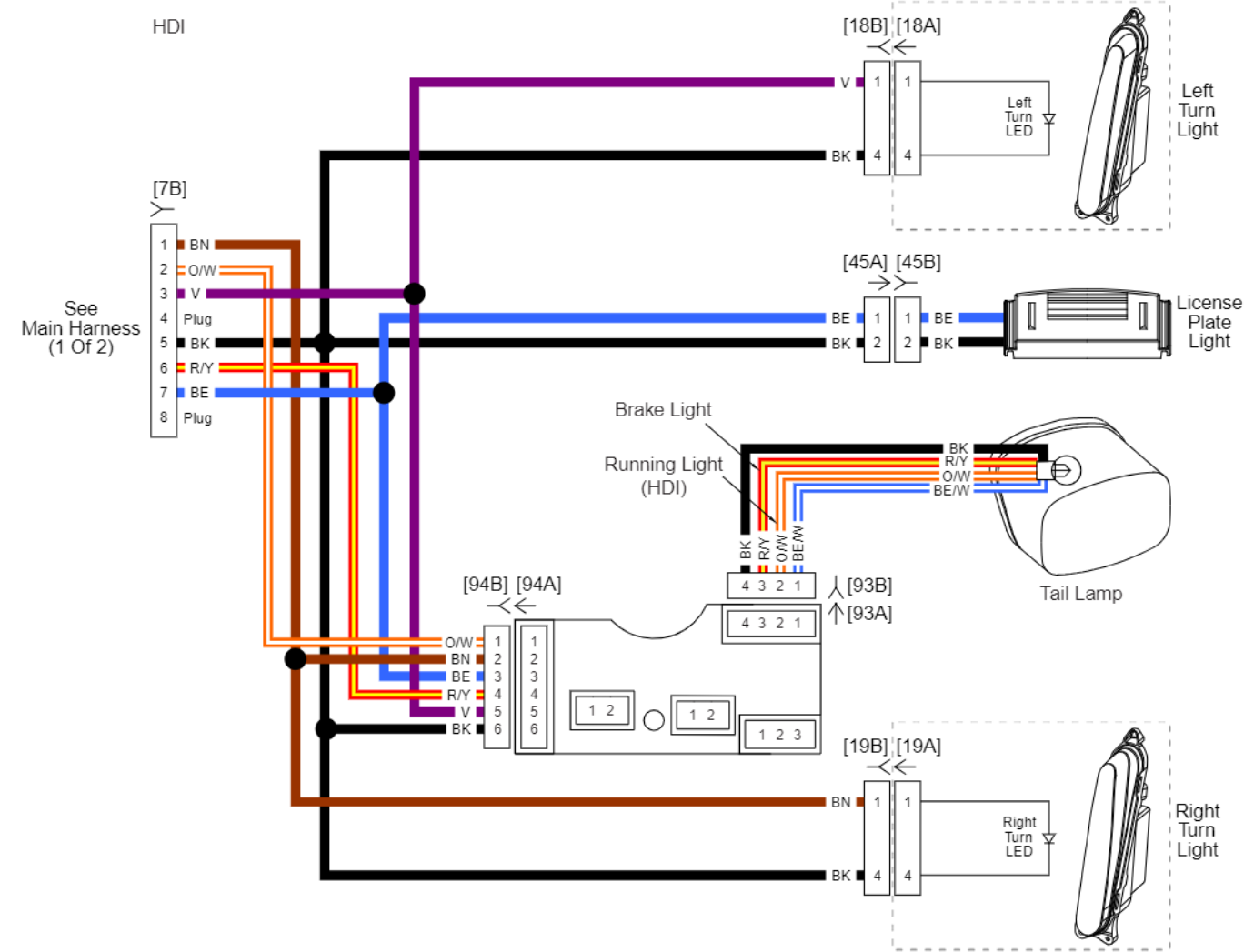
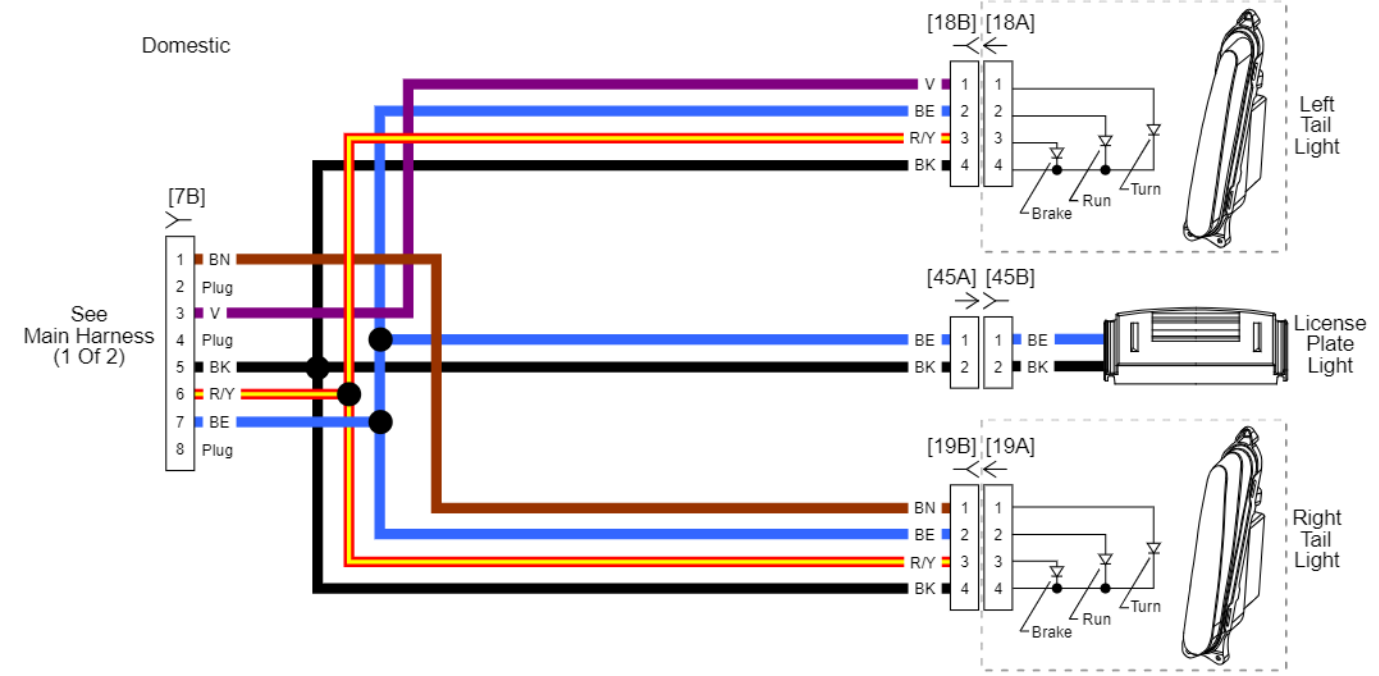
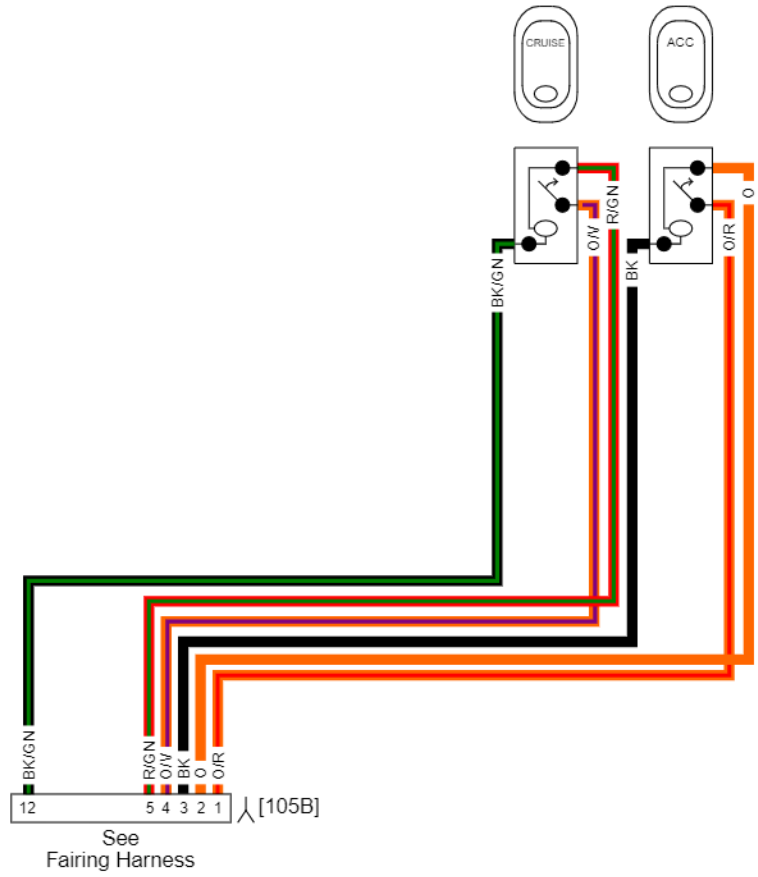
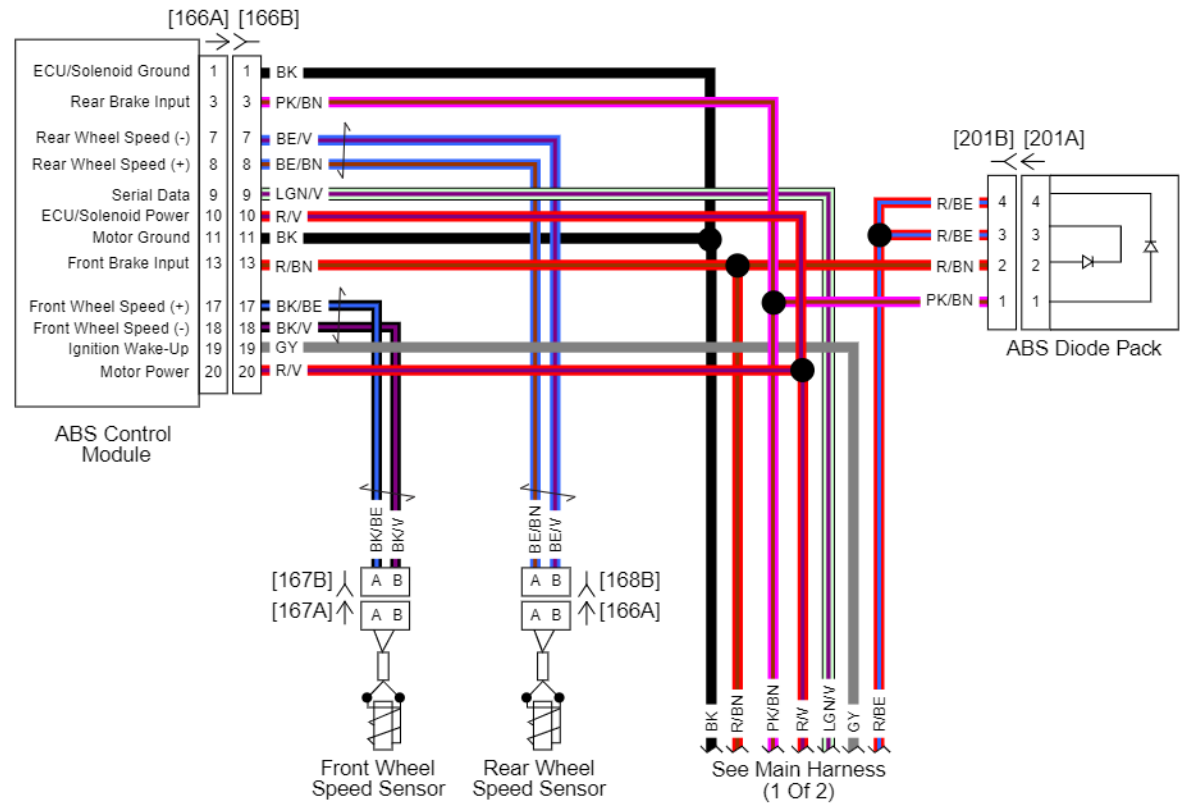

ABS, Indicator Lamps and Rear Lighting: 2012 FLHXSE3

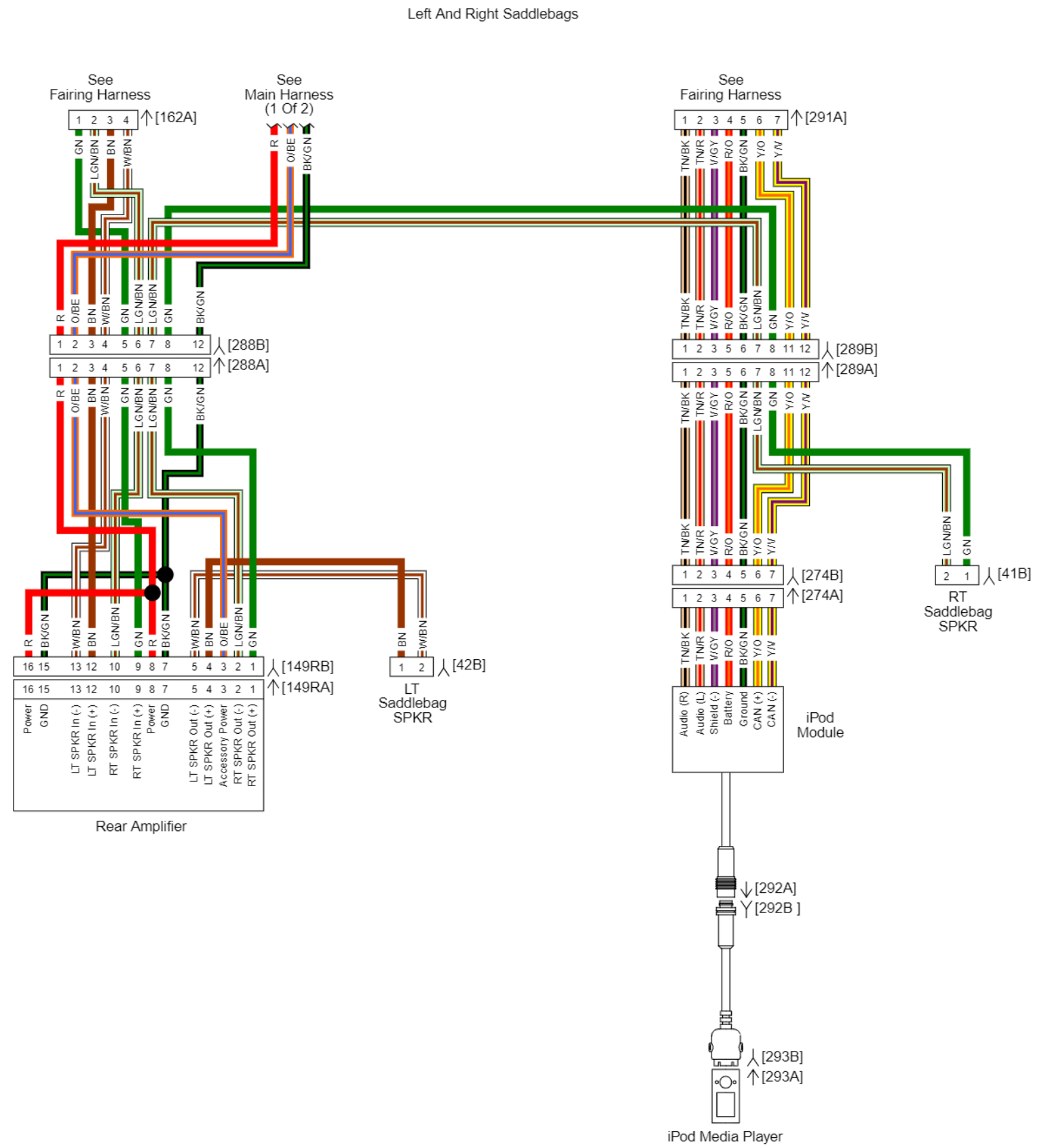
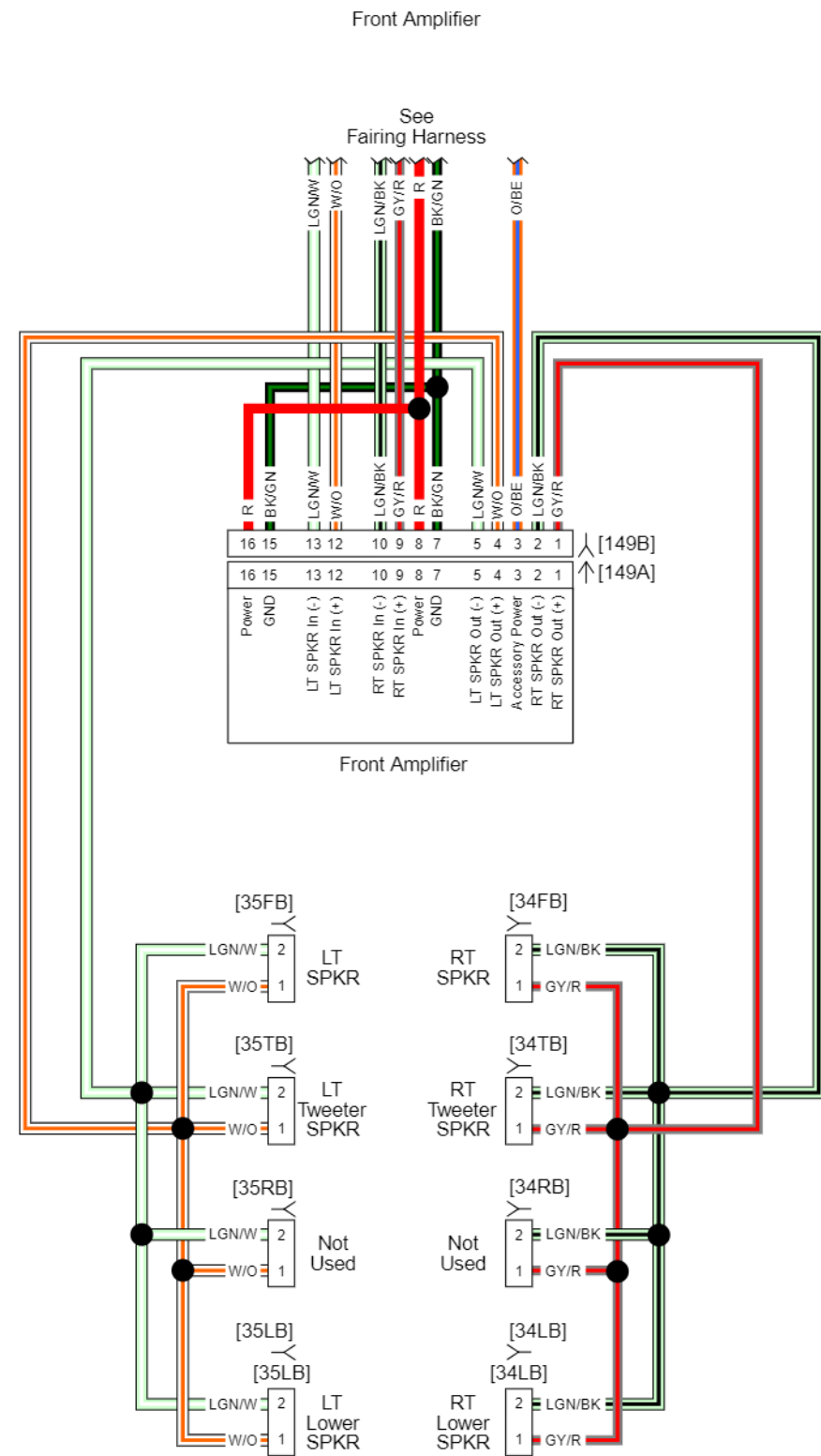

Audio: 2012 FLHXSE3

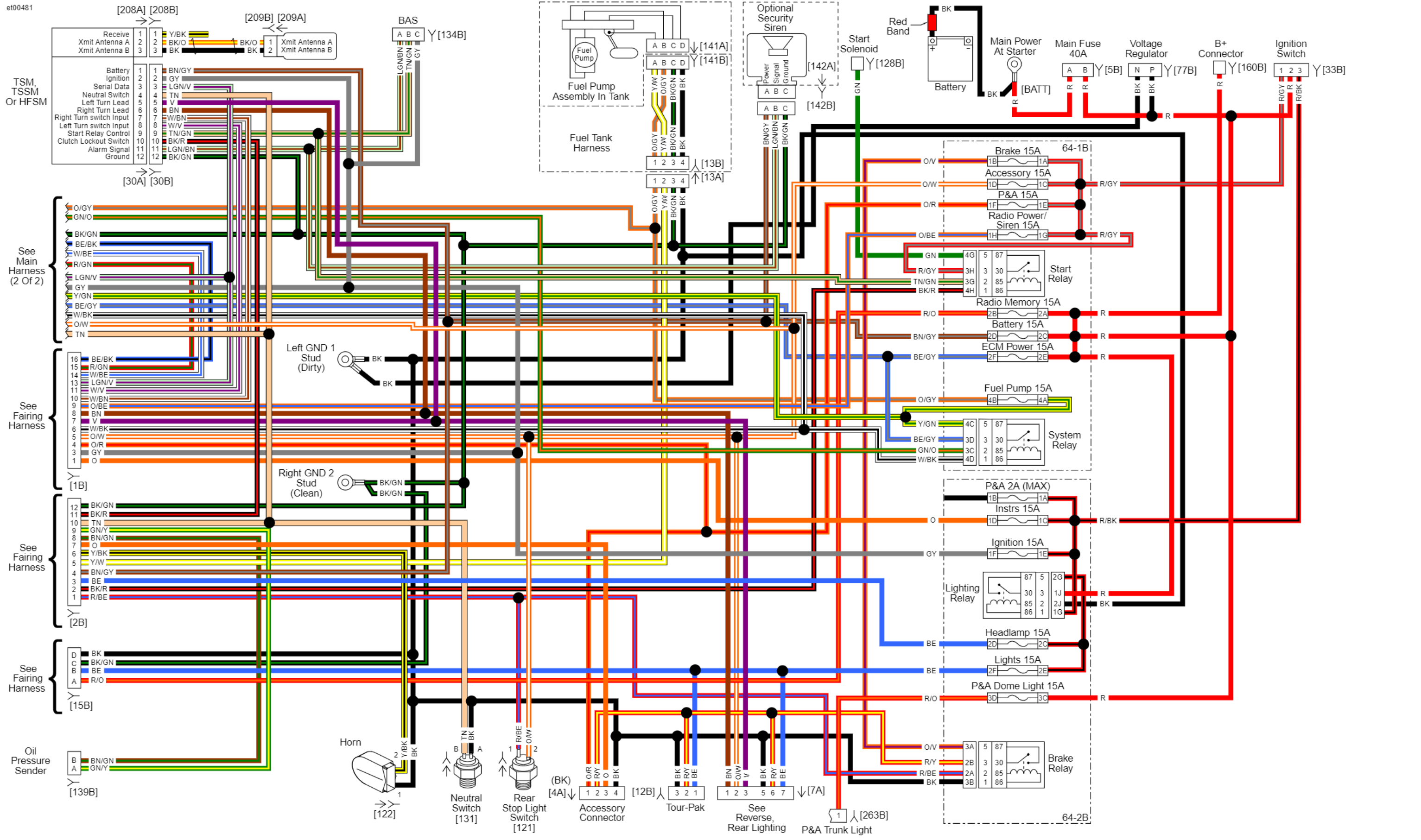

Main Harness (1 of 2): 2012 Trike Models

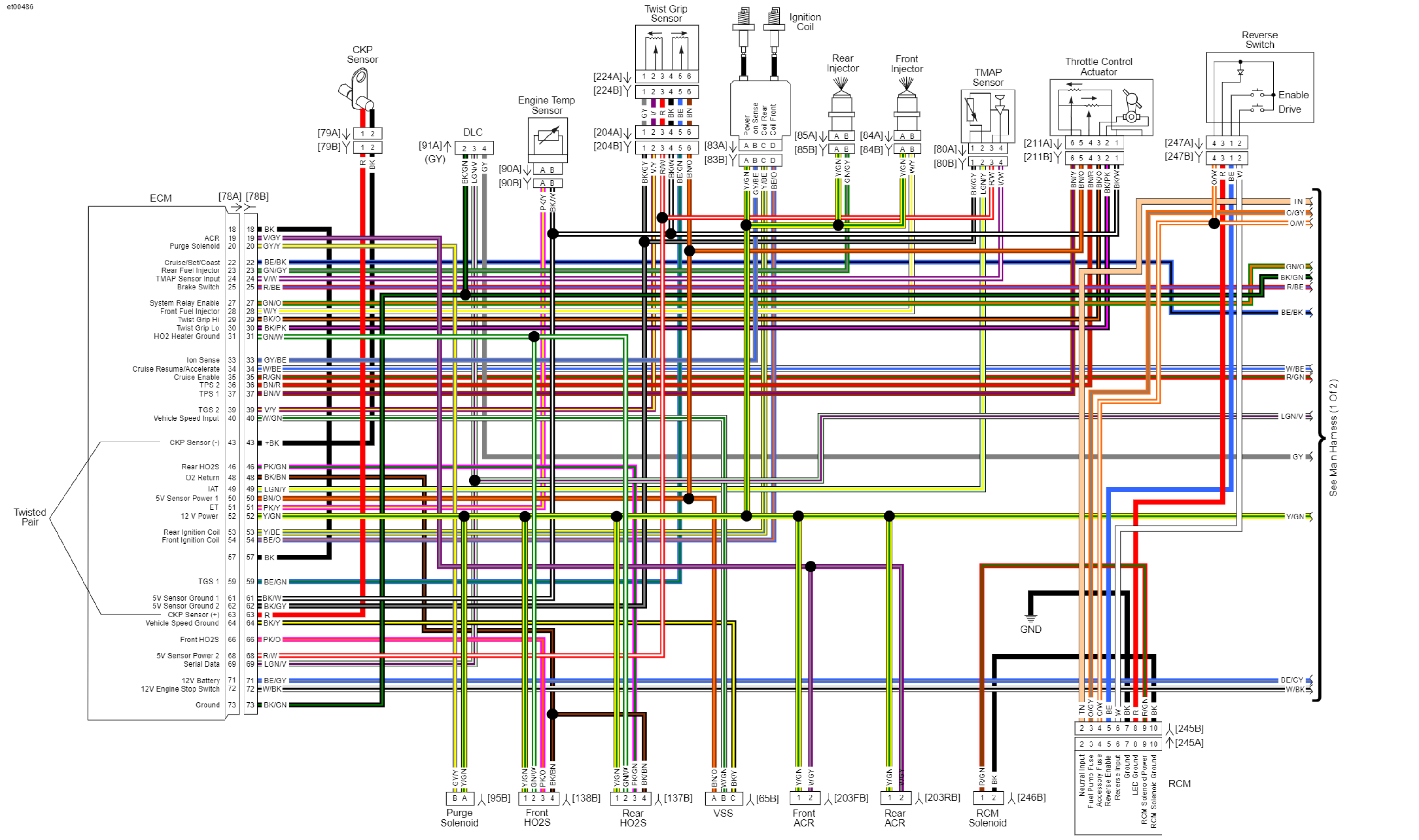

Main Harness (2 of 2): 2012 Trike Models

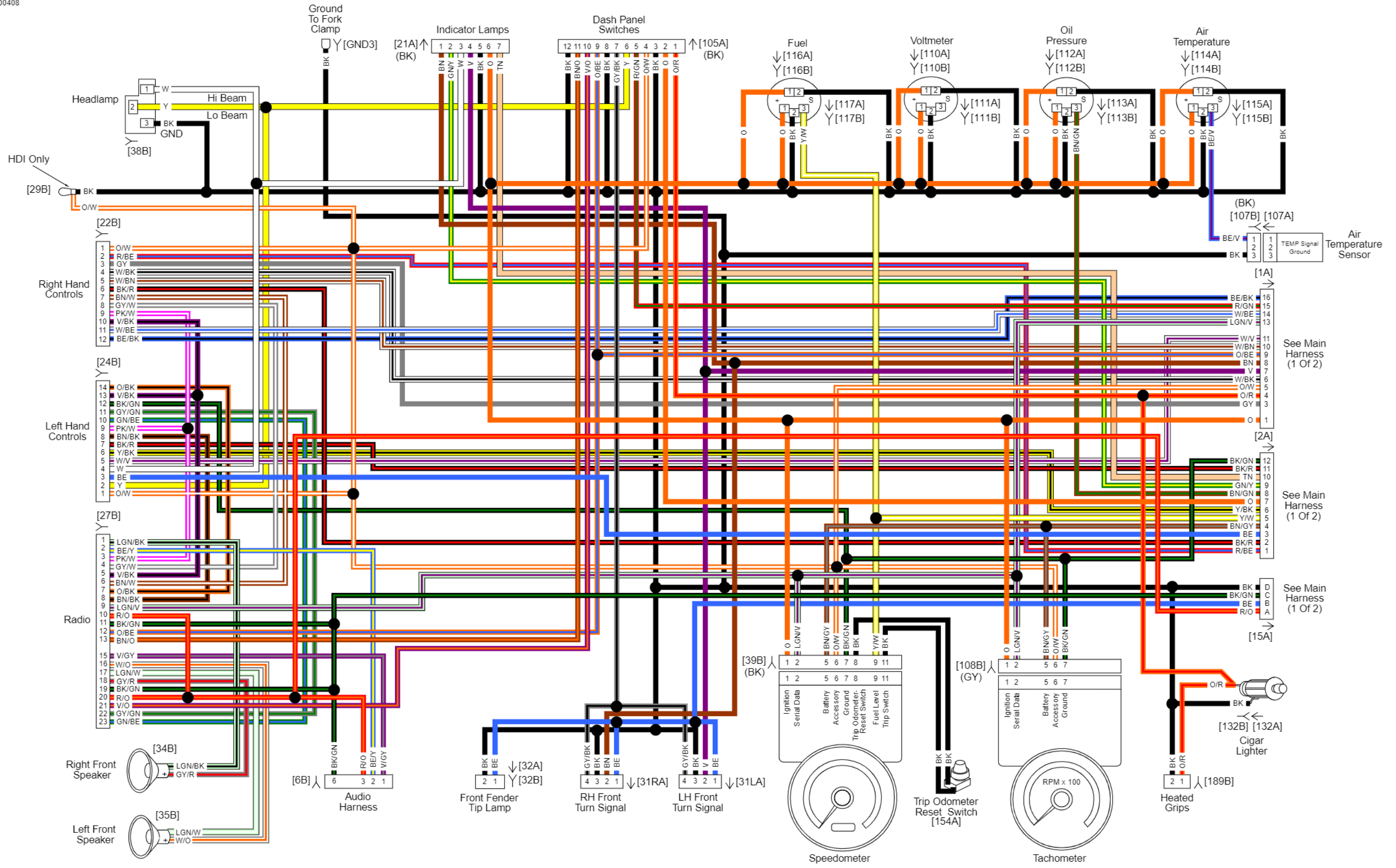

Fairing Harness: 2012 Trike Models

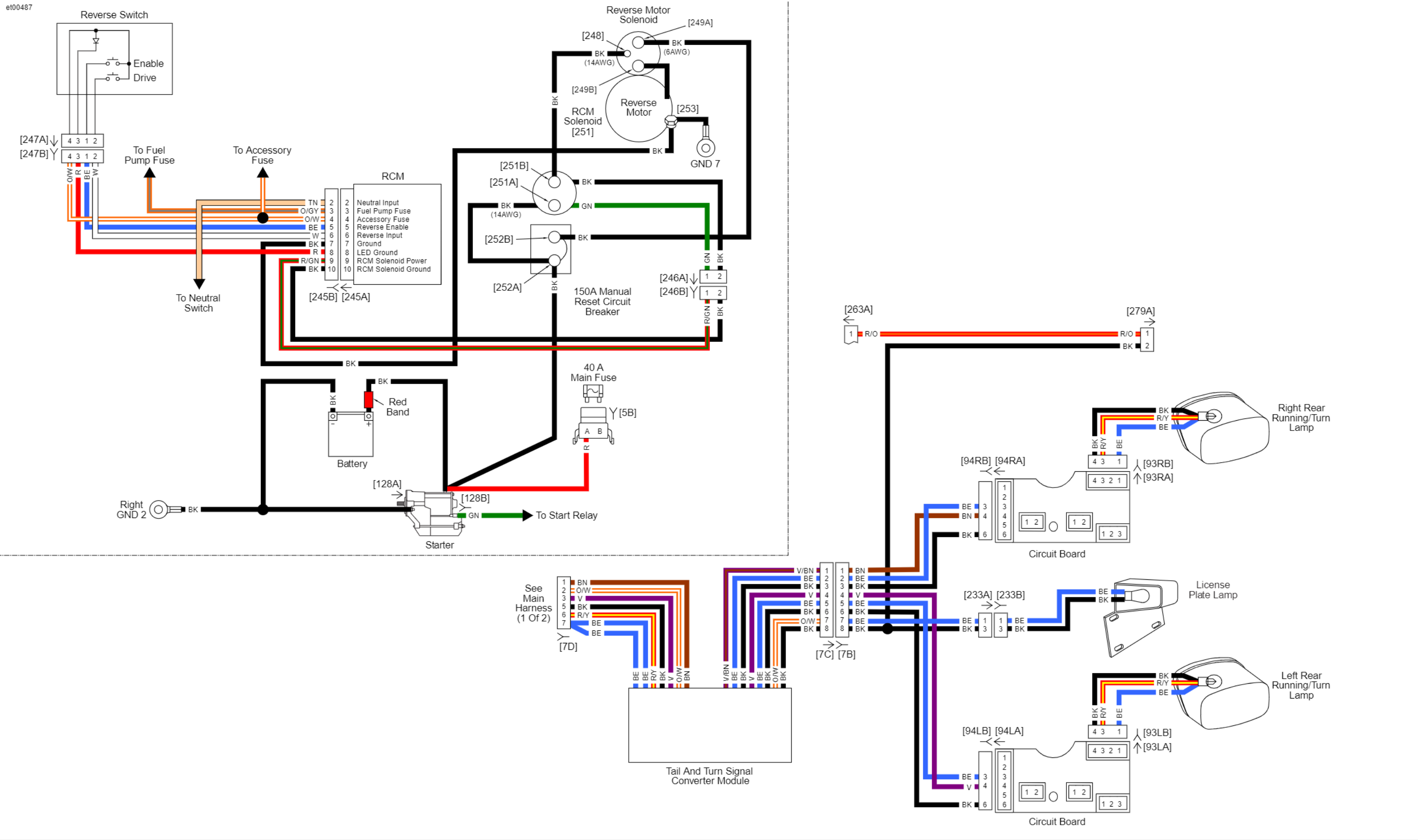

Reverse, Rear Lighting: 2012 Trike Models