

THE hafler POWER AMPLIFIER



DH-220

INSTRUCTIONS for OPERATION and KIT ASSEMBLY

CAUTION:
IF THE SPEAKER FUSES BLOW,
SOME DISTORTED SOUND CAN BE
HEARD. THEREFORE IF AMPLIFIER
MALFUNCTIONS, ALWAYS CHECK
FOR BLOWN FUSES FIRST.

LM 128
\$3.00

Please refer to this
serial number in all communications
regarding this equipment.

A

THE DAVID HAFLER COMPANY
5910 Crescent Boulevard, Pennsauken, New Jersey 08109

INTRODUCTION

The Hafler DH-220 is a two channel audio power amplifier designed to the very highest performance standards. It is available either as a kit, or fully assembled. Its 115 watt per channel power rating is sufficient for driving all loudspeakers in home applications, and its design assures extremely low distortion of all types. A combination of high performance, dependability, reliability, and moderate price is in the Hafler tradition of using the very latest technology to provide outstanding value.

The DH-220 circuit is a refinement of the DH-200 design, a Hafler landmark which has achieved worldwide recognition, and has elicited glowing reviews since its 1979 introduction. As in the DH-110 preamplifier, particular attention has been paid to component quality, using polypropylene or film capacitors wherever feasible, for example, for superior sound.

Combining the latest power MOSFET technology with uniquely simple and effective circuit topology reduces distortion of all types, and at all power levels, over the full audio frequency spectrum, to the vanishing point. In addition to its pace-setting performance achievements, the conservative mode of operation accomplishes a new high in long term reliability and exceptional resistance to abusive operating conditions. This is one of the direct benefits of MOSFET utilization in overcoming a serious limitation of conventional transistors – their tendency to self-destruct under other than normal operating conditions. So rugged is the DH-220 that it can deliver more than ten amperes into a short circuit!

The speed – measured as the slew rate – of this design delivers unmatched transient linearity, revealing the most delicate shadings, textures and nuances of the music, surpassing the capabilities of the most revealing loudspeakers and cartridges by a wide margin. Coupled with its unconditional stability, and ability to deliver adequate power into any loudspeaker load, the result is absolute freedom from listening fatigue. The longer you listen to this phenomenal amplifier, the more certain you will be that you could not have made a better choice.

The oversized power transformer and bridge rectifier; the massive heat sinks; the conservative operating levels of the MOSFET output devices – all are evidence of the design efforts to achieve exceptional reliability simultaneously with state of the art sonics and specifications. And this circuit is convertible to a high power monophonic amplifier with comparable stability and specifications.

The fully complementary, symmetrical push-pull circuit, which is direct coupled throughout (except at the input), incorporates all silicon devices in a format which is directly related to the highly acclaimed preamplifier. Its unique self-protecting output stage prevents the thermal runaway which is a common threat to solid state amplifiers. The ruggedness and conservative operation of the output stage allows the DH-220 to avoid the need for special protective circuits which could compromise audio performance. Basic protective systems provide maximum security against malfunction damage to the amplifier or the speaker: the AC line fuse, B + fuses, thermal breakers, and loudspeaker fuses. Nothing hinders the essential purity of the audio signal.

Those who use these instructions to assemble the DH-220 kit will find that the left and right audio modules (printed circuit and heat sink assemblies) are preassembled and pretested. This greatly simplifies the kit assembly so that it can be done in only a few hours without special skills or know-how. Because of the modular arrangement, it is possible to operate on one channel if the other requires service, and avoids the need to return the entire amplifier in cases where only one channel is at fault.

Accessories for special applications include provision for monophonic use; a panel for standard 19" rack mounting; and an alternative power transformer for international AC line voltages.

Through advanced engineering geared to the audio perfectionist, and an efficient no-frills approach, Hafler is making high technology high fidelity affordable.

CONTENTS

Operation	Page 3	AC Line Connections for Overseas Use. . .	12
Assembly Instructions	4	Kit Parts List	13
Wiring the Kit	6	Schematic Diagram	14
If Problems Arise.	10	Component Value Listing.	15
Service and Warranty	11	Pictorial Diagram.	Insert

INSTALLATION

The DH-220 is most likely to be installed out of sight in most applications, since its power may be controlled by the AC switching of most audio preamplifiers, like the Hafler DH-110. If your control unit does not provide switching capacity sufficient for the amplifier's 7 amp needs (plus other equipment it is also switching), you should use the amplifier's own power switch. In that case, turn on the preamplifier first; then turn the amplifier on a few seconds *after* the preamp has been turned on, to avoid any unnecessary turn-on transients from some preamplifiers. Likewise, switch the power amplifier off first.

If the amplifier is to be installed close to a record player, you should first check its position for freedom from hum pickup by the cartridge from the field radiated by the power transformer of the DH-220. Although the design of the transformer minimizes such radiation, certain cartridges are more sensitive

than others, and require separation from the amplifier. Check at a comparatively high volume setting, and while swinging the tone arm throughout its arc. Often a few inches additional spacing will eliminate the problem.

Be sure to provide sufficient *ventilation* for the amplifier. Unobstructed *air circulation* around the finned heat sinks and *above* the amplifier is important for long, trouble-free life. Never put anything on top of the cover perforations. It is normal for the top and the heat sinks to become warm in use.

It is expected that the amplifier will always be resting on its feet, which should be on a hard enough surface that air flow underneath is not obstructed. If it is mounted in a rack, or through a panel, the feet may be removed so long as adequate ventilation is provided through the bottom openings.

OPERATION

The red pilot lamp which is integral with the power switch glows whenever the amplifier is turned on. A blown AC line fuse is the most likely cause if it is not illuminated when the amplifier is switched on.

The pilot lamp also provides a high temperature indication. In the unlikely event that the amplifier ceases to function, and the amp blinks on and off steadily, it indicates that one of the thermal breakers has shut down the amplifier because of excessive temperature rise in a heat sink. When the heat has dissipated in a few minutes, the amplifier should return to normal operation. If the lamp again blinks, check for insufficient ventilation, or an excessive input signal, or an input which may have dangerous signal content (such as oscillation). Failing evidence of this, the amplifier may have malfunctioned. Because of the very large heat sinks, it is highly unlikely that any normal signal will cause the amplifier to overheat.

Loudspeaker Fuse Selection

The DH-220 power amplifier is supplied with 2 amp fuses in the speaker lines. Experience has shown that since an overload must exist for a few seconds for a fuse to blow, a 2 amp fuse will protect most speaker systems, and only blow when overload occurs. Smaller fuses tend to blow too easily, and larger fuses do not adequately protect most speaker systems.

A pair of 5 amp fuses are also supplied as alternatives for the speaker fuse holders. These should be substituted if the power output of the amplifier is to be tested, and these or intermediate values may be used if the amplifier is to be operated at very high power levels into 4 ohm loads.

If the manufacturer of your speakers recommends a specific value of fuse for their protection, we suggest that you obtain AC fuses of that value and install them in the back panel.

Loudspeaker Power Ratings

There are no U.S. standards for rating the power handling of loudspeakers. As a result, the manufacturers' usual "music power" ratings, or suggested amplifier limits, are of only minimal help in determining safe operating levels with amplifiers which can deliver substantial amounts of power. You must take into consideration the type of music, and the levels you like, to provide long term trouble-free operation of your speaker choice, when you have a sizeable amplifier like the DH-220.

Connections

AC

The AC power cord should be plugged into 120 volts, 60 Hz, on the switched outlet of a preamplifier which can provide at least 7 amps, or 840 watts. Then the amplifier power switch may be left on, and it will be controlled by the rest of the system. Or, it may be plugged into a 120 volt wall outlet, and switched on and off independently.

If your line (mains) voltage is different, be sure you have the alternate power transformer which can accommodate several line voltages, and be sure it is wired for your mains voltage as described later in this manual *before you plug in the amplifier*.

Input

Conventional shielded cables, such as those supplied with your preamplifier, provide the input signal to the sockets on the back panel of the DH-220. Be sure that the outer shield connection is secure, to avoid hum. The length of these cables (so as to permit remote location of the amplifier, if desired) is limited only by the output impedance of the preamplifier. If it is 600 ohms or less, as with the _____ and DH-110 Hafler preamps, for instance, cable lengths up to 50 feet are permissible without loss of

performance. Special low capacitance cables enable even greater distance between preamp and amplifier. It is desirable to keep the left and right input cables close together throughout their length to minimize the likelihood of hum pickup. Also, you should avoid running them parallel to AC cords – these should be crossed at right angles.

Output

The loudspeakers (or headphones) connect to the red and black terminals on the back panel. These binding posts provide several convenient alternative connecting methods. The screw cap may clamp the bared wire end, or a “spade lug” attached to it, but a better connection will be made by locating the hole drilled through the shaft of the terminal when the cap is unscrewed. Insert the twisted end of the bared wire so that the cap will clamp it in place. Always be sure that no strands of wire are unsecured, and that the bared end is not too long to risk contacting other elements. A soldered end or fitting is the safest solution.

These terminals also accept standard plug-in “banana pin connectors,” including the double ones with standard 3/4” spacing, available from electronic supply houses. These are the most convenient, especially if you may wish to interchange speakers occasionally.

It is important to maintain correct phasing of the speakers when making their connections. Some speaker terminals are coded red and black, or + and -, etc. It is important that the “sense” of one speaker’s connections match the others. If one is reversed, you will find that the sonic image has a “hole in the middle,” and that it is deficient in bass. Speaker wire always identifies one conductor to make this easy. There may be a molded ridge in one lead, or the color of the insulation on one wire is different, or the wire itself may be color coded. If pin

plugs are used, be sure they are color coded, or that you follow the indexing mark on one side of the double connectors.

Select speaker wire of sufficient size to preserve the high damping factor (and excellent speaker control) of your amplifier. Standard 18 gauge lamp cord (“zipcord”) is satisfactory for distances up to 30 feet for an 8 ohm speaker. As the distance increases, larger wire sizes are recommended. The next larger wire size is #16, and it is often preferred by perfectionists. If you have 4 ohm speakers, the maximum cable length for best results is halved.

The black output terminals are electrically connected to the chassis internally. Be certain that when the amplifier is operated in its normal stereo mode that the red output terminals are never connected together. In the special case when the amplifier has been internally modified for monophonic bridged operation, the output is taken from the two red terminals *only*. Then, the black terminals are left unconnected.

Headphones are normally operated from the loudspeaker outputs, but are usually connected through a junction box which provides switching from phones to speakers. Such a box usually provides some added resistance to reduce the sensitivity of the phones, and thus minimize the likelihood of hearing component noise, because of the low setting required at the volume control. Some headphone boxes utilize a “common ground” system which makes it particularly important that you carefully observe the proper connections. While the black ground terminals can be connected together, the red ones must not be.

Some headphones, such as electrostatic types, are less sensitive and may need little or no resistance in series for normal operation. These could be easily interchanged with the speakers through the use of double banana plugs.

KIT ASSEMBLY INSTRUCTIONS

There are three basic rules for success in electronic kit building:

1. Read the instructions carefully, and follow them in order.
2. Make secure solder connections which are bright and smooth.
3. Check your work carefully after each step.

The DH-220 amplifier is a versatile component with sophisticated circuitry which has been made remarkably easy to build by individuals with many years of experience in the design and engineering of the finest performing audio kits, and in the preparation of their manuals.

Kit building should be fun, and we are certain you will find this to be so. Assembly will be faster, easier, and more enjoyable if you have someone help you by reading the steps aloud, selecting the required parts, and preparing the necessary wire lengths in advance as you proceed. Fatigue increases the risk of error, so take a break rather than push to early completion. There are relatively few separate components in this design, to make it easy to pack everything away, if need be.

Your work area should have good lighting, the proper tools, and a place where the large pictorial diagram can be positioned within easy reach for checking. The tools should include:

1. A 40 to 100 watt soldering iron with a 1/4" or smaller tip which reaches at least 600°F.
2. 60/40 (60% tin) ROSIN CORE solder, 1/16" diameter or smaller. (Smaller diameters are easier to work with.)
3. A damp sponge or cloth to wipe the hot top of the iron.
4. A wire stripping tool for removing insulation. This can be a single-edge razor blade, but inexpensive stripping tools are safer, faster and easier.
5. A medium-blade screwdriver (about 1/4" wide).
6. Needle-nose pliers (a long, narrow tip).
7. Diagonal or side-cutting small pliers.
8. Large “gas” or “slip-joint” pliers.
9. A 1/4" “Spin-tite” nut driver may be helpful, but is not necessary.

A soldering “gun” is *not* recommended. The unfamiliar user is more likely to damage the etched circuit boards with its higher heat potential and unbalanced weight. Also, because he may not wait long enough for it to reach operating temperature each time it is switched on, poor solder connections are more likely. Pencil irons are much lighter and easier to use, and there is no waiting time when solder connections follow in sequence, as in kit building. Make sure you have a holder for it, though, and always unplug it when you take a break.

Proper Soldering

There are four steps to making a good solder connection:

1. Make a good mechanical connection to hold the wire in position while heat and solder is applied.
2. Heat *the junction* of the wire and lug, or hole, with the bright, shiny top of the iron.
3. After heating for a couple seconds, apply solder to the junction. It should melt immediately and flow smoothly around both surfaces.
4. Allow the connection to cool undisturbed.

Remember that the connection is made by the solder, not by mechanically attaching the wire to the terminal. Usually the wire is looped through the lug and crimped in place, but some prefer to just place it through the hole and rely on the stiffness of the wire to hold it while soldering. Connections to numbered holes on the circuit board are handled this way.

Good solder connections are *essential* for trouble-free noise-free operation. A good solder joint does not require much solder around the conductors. Never “butter” partially melted solder on the joint, as it is useless. A good connection looks smooth and bright because the solder flows into every crevice when the parts are hot enough. The iron must have a bright, shiny tip to transfer heat easily to the junction. That’s why the damp sponge should be used frequently to wipe the tip, and occasionally you must add a small amount of solder to the tip, too. If a connection is difficult to heat, “wet” the tip with a small blob of solder to provide a bigger contact surface to the joint. Once the solder flows around the conductors, any movement must be avoided for a

few seconds to allow a good bond. When cool, check the connection by wiggling the wire. If in doubt, or if the connection is not shiny, re-heat the joint. Excess solder may be removed from a connection by heating it and allowing the solder to flow onto the iron, which is then wiped on the sponge.

ALL SOLDER USED MUST BE ROSIN CORE.

Never use acid core solder or any separate flux in electronic work. Silver solder is also not suitable. If in doubt about unmarked solder, always obtain a fresh supply of rosin core solder. We recommend 60/40 for easiest use. Do not confuse it with 40/60, which is harder to melt.

The general procedure is to use a hot iron for a short time to heat a connection, then add solder with the iron still in contact. Remove the solder once it flows, and then remove the iron. A cooler iron applied for a longer time is more likely to damage components, or lift the copper circuit pattern from the boards. A break in the etched circuit can be mended by simply soldering a small piece of wire across it. Do not allow much build-up of solder on the tip of the iron, or it may fall into adjacent circuitry.

When soldering to a numbered hole on the board, insert the wire from the components side, and apply the iron, leaving some bare wire exposed so that you can see that the hole is then filled with solder for a secure bond. A round wooden toothpick is suggested so that you can heat and clear the hole of solder if it hinders your inserting the wire. Some builders prefer to clear every hole first with a touch of the iron and toothpick. If the wire has first been “tinned,” no additional solder may be necessary if solder fills the hole, but it is good practice to push the wire through, and then back it up a bit, to be sure solder fills the hole from both sides. Make certain a bright, shiny flow is evident from the wire, across the hole, onto the circuit pattern on the board.

“Tinning” refers to the process of applying a light coating of solder to the bared wire end. This keeps all the strands secured, and also makes a good connection easier. Simply touch the wire with the iron for a couple of seconds, and apply solder. Allow the excess to flow away onto the iron. When properly done, the wire is uniformly bright, and no larger than before. The hookup wire supplied with this kit does not normally need tinning, for it is pre-tinned.

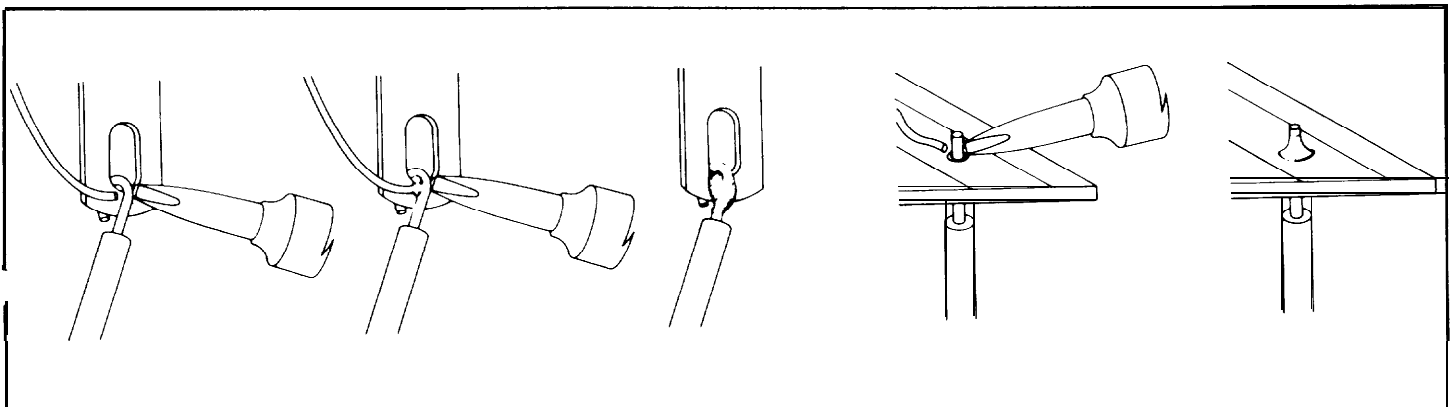

Wiring the Kit

If any components are unfamiliar to you, checking the pictorial diagram should quickly identify them. Or, the quantities, and the process of elimination as you check the parts list, will help. The pictorial diagram is necessarily distorted to some extent for clarity, so that you can trace every wire in a single overall view for verification as you work. You may wish to check off on the diagram as you solder each location.

To “prepare” a wire means to cut the designated length from the coil of that color, and strip about 1/4" of insulation from each end. The wire supplied in the kit is #18, so you can set adjustable wire-strippers accordingly. The transformer leads are #16 or #18 and the line cord is #16. Be careful that you do not nick the wire when you strip it (that can happen more easily if you do not use wire strippers) for that weakens it. The wire supplied in this kit is “bonded stranded,” which provides exceptional flexibility with resistance to breakage for easier use, and it is pre-tinned.

Whenever a connection is to be soldered, the instructions will so state, or indicate by the symbol (S). If more than one wire is to be soldered to the same terminal, they will be indicated by (S-2), (S3), etc. If soldering is not called for, other connections have yet to be made to that terminal. They would be more difficult if the connection was already soldered. Every connection in the kit will be soldered when it is complete. After soldering a connection, it is best to clip off any excess lead length to minimize the possibility of a short circuit (as on switch lugs, where terminals are very close together), and for a neat appearance.

Be sure that uninsulated wires cannot touch adjacent terminals or the chassis metalwork.

The symbol (#) indicates a connection is to be made to that point. When a lug number is specified without (#) it is simply a locating reference.

When the instructions call for twisting two or three wires together, the length of wire indicated anticipates a fairly tight, uniform twist by hand, of three full turns every two inches. If you find the wires too short, loosening the twist will gain some needed length.

Handle the circuit boards carefully. They represent a major part of the kit cost. Stand-up components, such as transistors, should be checked when you install the module, to be sure all leads are separated.

All of the active circuitry is contained on the PC-19 board, which has been carefully tested to assure that it meets every specification. Only the interconnection of power supply elements is left to the builder. Take the time to be accurate and neat, and you can be sure that your completed amplifier will meet the performance of a factory assembled unit, and can continue to perform properly for years to come. Check your work, and make sure the entire step has been completed before placing a check mark in the space provided, and continuing on to the next step.

KEP nuts have been supplied as a convenience. These have lockwashers attached, and the lockwasher always goes onto the screw first. If the sheet metal screws have hex heads, you may

find it easier to first start them with a regular screwdriver, to set the thread, and then use the more convenient nut driver, if one is available.

Mechanical Assembly

- 1 When you unpack your kit, you will find that the transformer, large capacitors, and the output assemblies have been temporarily fastened to the chassis for safe shipment. Disengage these, and include this hardware with the rest when you check off the components against the parts list in the back of the manual. We recommend this check-off to be sure you have everything, and to enable you to identify any unfamiliar items by comparing them with the pictorial diagram. An egg carton is ideal for keeping hardware items separated.

A “set” of hardware includes one screw and one KEP nut (with its attached lockwasher). Always install the lockwasher side of the nut first. If the size of the hardware is not specified, use the #6 size. The smallest size is #4 and #10 the largest. Always insert the screw from the outside of the chassis.

It will simplify matters if you first separate the #4 nuts from the #6 nuts, which have the same outside dimensions. A #4 screw will pass through a #6 nut, aiding identification.

- 2 Select the four rubber feet, four sets of #6 hardware, and the chassis. Insert each screw through a foot so that the head is recessed, and install the feet on the outside at each corner hole.
- 3 Select the two red output terminals. Install them in the sequence shown below, in the two center holes LR and RR marked '+' at the rear of the chassis. Before you fully tighten the first nut, unscrew the cap to expose the hole drilled through the threaded shaft. Connection of loud-speaker wires will be easier if these holes are positioned vertically. A nail through the hole will keep it positioned while the hardware is tightened. Each connecting lug should point downward before the last nut is secured. Be sure both nuts on each terminal are **tight**, as they are difficult to reach when the amplifier is completed.

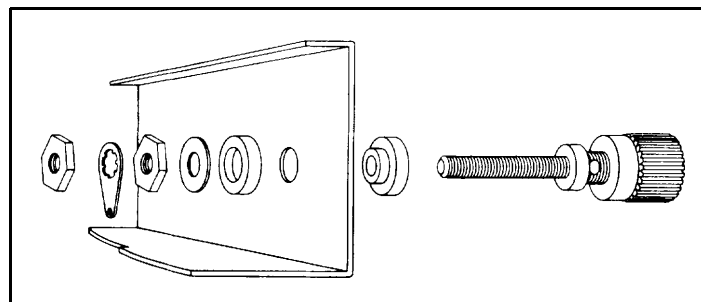

- 4 Select the two black output terminals and install them on either side of the red ones, at LB and RR. Be sure the shaft holes are vertical, the lugs point downward, and each nut is tight.

5 Select the two round fuse holders, and two each 1/2" rubber washers, lockwashers and nuts. First install the rubber washer on the holder, so it will be outside the chassis, and then fasten the fuse holders at LF and RF, with the tip lugs pointing towards each other, toward the center of the chassis.

6 Select the two input sockets and 4 sets of #4 hardware. Install the sockets **inside** the chassis at LS and RS so that the short lug of each socket is near the hole between the two sockets.

7 Select the single ground lug (with lockwasher teeth) and one set of #4 hardware. Install it between the input sockets, pointing toward the bottom. Bend it out for access, and twist it 90° for easier insertion of a wire later. Be sure this lug is **tight**, as the locking teeth must cut through the chassis paint for a good ground connection.

8 Select the four-lug diode block DB, the long #6 screw, and a nut. Install the rectifier in the center hole near the rear of the chassis, with the plus (+) terminal located over the tiny indexing hole at position four. Correct orientation of this rectifier is **essential** for proper wiring.

9 Select the single fuse clip, and one set of #4 hardware. Install the clip in the right front chassis hole FC, closest to the foot.

10 Select the two dual fuse clips and four sets of #4 hardware. Install these in the pairs of holes FL and FR on either side of the center of the chassis.

11 Select the 5-lug terminal strip and two sets of #4 hardware. Install it in the front holes TS, next to the single fuse clip. Note the position of the mounting lugs (to the right) in the pictorial diagram.

NOTE: Kits provided with the multiple voltage power transformer for use in locations outside the United States having a line (mains) voltage other than 120 VAC are also supplied with an additional two-lug terminal strip which is to be installed using an additional set of #4 hardware on the other side of the chassis, below the dual fuse clip FL.

12 Select the power switch. Install it with the red window to your right as viewed from the front. The switch snaps into chassis hole PS from the outside.

13 Select the AC line cord and the plastic strain relief. Separate the two conductors for 2". Cut 1" off one of the two leads, and strip 1/4" of insulation from each lead. Twist the strands tightly, and tin each end. Make a sharp 'V' in the cord 8 1/2" from the longest cut end by bending it back on itself. Install the relief with the small end nearest the cut end of the cord. Crimp the two halves of the relief around the wire at the 'V' with heavy pliers, to partially form it before insertion into back panel hole AC. Then grip the larger diameter with the plier tips, squeeze it tightly, and insert the cord and the relief from the outside. A flat side of the relief mates with the hole shape, and it snaps into position when fully inserted.

Connect the shorter lead to FC lug #1. (S). Connect the longer lead to the **lower** hole of TS lug #2. (S). Note that lug 2 is the second protruding lug on the terminal strip. It is **not** the mounting bracket for the terminal strip. Soldering this lead to the lower hole now will make later connections to the top portion of the lug easier. Be sure no stray strands of either line cord conductor are left unsoldered.

14 Prepare a 6 1/2" green wire. Connect one end to dual fuse clip FL lug #1. Connect the other end to the other dual clip FR lug #1. (S).

15 Prepare a 6 1/2" white wire, Connect one end to FR lug #3. Connect the other end to FL lug #3. (S).

16 Prepare two 7" white wires. Start with one wire projecting 3/4" beyond the other, and twist them uniformly together throughout their length. Connect the projecting end to RF lug #1. (S). Connect the corresponding end of the other wire to RFlug #2. (S). Place this pair over the right edge of the chassis.

17 Prepare two more 7" white wires. Start as before with one wire 3/4" longer, and twist them together. Connect the longer end to LF lug #2 (S). Connect the other wire to LF lug #1. (S). Place these wires off to the left.

18 Prepare an 8" green wire and a 10" white wire. Start with the white wire 3/4" longer than the green wire, and twist them uniformly together. Connect one end of the green wire to the lug on black output terminal LB. Connect the corresponding end of the white wire to red terminal LR. (S). Place these wires off to the left.

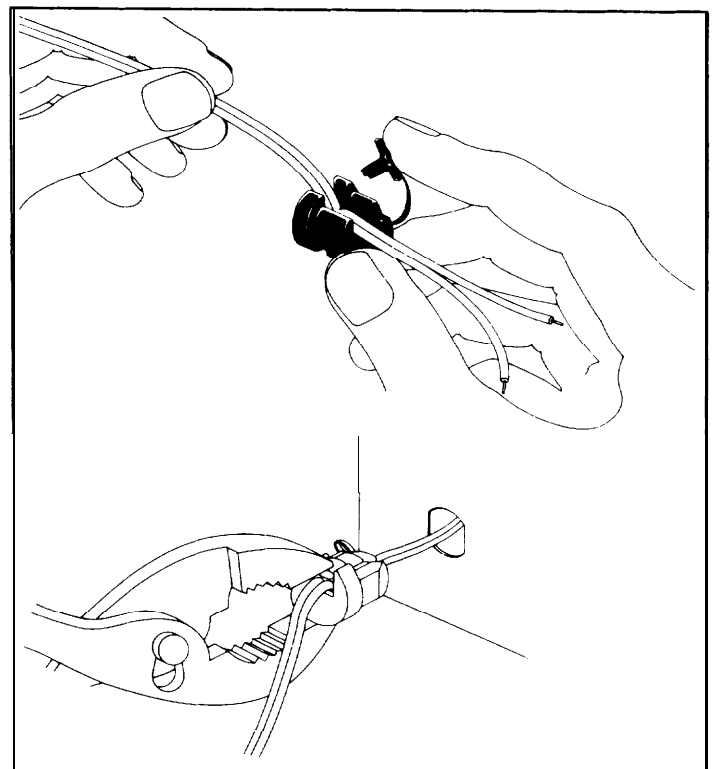

- 19 Prepare a 7" green wire. Connect one end to terminal LB. (S-2). Place this wire towards the center of the chassis.
- 20 LI Prepare a 10" white wire and a 10" green wire. Starting with the white wire 3/4" longer, twist them together. Connect the projecting white wire to red terminal RR. (S). Connect the green wire to terminal RB. Place these wires off to the right.
- 21 Prepare a 5 1/2" green wire. Connect one end to terminal RB. (S-2). Place this wire towards the center of the chassis.
- 22 Prepare a 16" green wire, but strip 1 1/4" of insulation from one end. Prepare a 15" white wire. Start with the normally stripped (1/4") ends even, and twist these wires uniformly together. Thread the longer bared end of the green wire through LS short lug #2 from the top left, then through GLlug #3, and connect it to RSshort lug #4. Solder only LS lug #2. Connect the corresponding end of the white wire to LS lug #1. (S). Place this wire up under the chassis rear lip, above the output terminals, and off to the left.
- 23 Prepare a 6 1/2" green wire. Connect one end to CL lug #3. (S2). Place this wire over the rear of the chassis.
- 24 Prepare a 10" green wire and a 10" white wire. Twist these together with the ends even. Connect the green wire from the right to RS short lug #4. (S-2). Connect the white wire to RS lug #5. (S). Place these wires off to the right.
- 25 Prepare two 22" white wires, and twist them together throughout their length. 8" in from one end of the pair, cut **one** of the wires, and unwind it about 1 1/2" in each direction from the cut. Strip 1/4" of insulation from each of these cut ends. Place the longer portion of the wire along the lower front edge of the chassis, with the break at the terminal strip TS. Connect the cut end from the left to TS lug #2. Connect the other end to the **lower** hole of TS lug #5. (S). Place this pair along the front edge of the chassis, under the power switch, with the ends projecting from the front corners of the chassis.
- 26 Select a 1 megohm resistor (brown-black-green) and trim the leads to 1/2". Connect one lead to TS lug #2. (S3). One of these 3 leads has already been soldered to the lower lug hole. Connect the other lead to TS lug #3.
- 27 Select the diode and trim its leads to 1/2". Note that one end of the diode is marked with a stripe (or an arrow head will point to that end). Connect the marked end to TS lug #4. Connect the other lead to TS lug #3. (S2).
- 28 Prepare a 4" green wire. Connect one end to TS lug #4. Select a spade connecting lug, and solder it to the other end. Place this wire down against the chassis, and connect it to the PS lug on the right, near the edge of the chassis.
- shorter, middle set of tabs tightly around the bare wire, and then bend the longer tabs around the insulation. Then flow solder into the joint around the bare wire, keeping the solder away from the spade section.
- 29 Prepare a 2" white wire. Connect one end to FC lug #2. (S). Select another spade lug, and solder it to the other end. Connect it to the PS middle lug.
- 30 Select the 0.39 mfd (.39K) capacitor and trim its leads to 1/2". Connect one lead to TS lug #4. (S3). Connect the other lead to TS lug #5.
- 31 Select the two large round capacitor brackets, the two large capacitors, and 6 sets of #6 hardware. Place a bracket around the bottom of each capacitor, and fasten it snugly with one set of hardware through the clamp. Note the direction of insertion of the screw for easy servicing access in the future. The clamps need not be tightened now – just made snug. Place each assembly on the chassis, at CL and CR, noting the position of the clamp, and fasten them securely. Be sure no wires are trapped by the bracket. Then loosen the clamps, and position the capacitors so that each + terminal is positioned as in the pictorial diagram. The + terminal will usually be so marked, but if not, it may be identified by a red dot. Note that the + terminal of CL is nearest the - terminal of CR. Make sure the capacitors are seated against the chassis and tighten both clamps.
- 32 Select the 4 plain solder lugs and then 4 short #10 SEMS screws (with lockwasher attached). Install these in the capacitors, with the lugs pointing as in the diagram.
- 33 Prepare a 6" green wire. Connect one end to DB lug #1. (S). Connect the other end to CL lug #1.
- 34 Prepare a 4" green wire. Connect one end to FL lug #1. (S-2). Connect the other end to CL lug #1. (S2).
- 35 Prepare a 6" white wire. Connect one end to DB lug #4. (S). Be sure this is the + terminal of the rectifier. Connect the other end to CR lug #2.
- 36 Prepare a 4 3/4" white wire. Connect one end to FRlug #3. (S-2). Connect the other end to CR lug #2. (S2).
- 37 • 1 Remove all insulation from a 3" white wire. Connect one end to CL lug #2. (S). Connect the other end to CR lug #1. (S).
- 38 Select the power transformer, the 4 flat washers, and the 4 sets of #10 hardware. Position the transformer with the red leads to the center rear of the chassis, and the black and black/white leads towards the power switch. If the transformer is the special multiple voltage version, the additional leads should be placed as shown elsewhere in this manual for the desired line (mains) voltage.

The red/yellow lead will likely be the correct length. If you wish to shorten the red leads for neatness in connecting them to the rectifier terminals, it is easier to strip them before the transformer is mounted.

Place the white pair of wires under the front chassis lip. Install a flat washer on top of each transformer foot after the screw is inserted from below, and then add the nut. Be sure no wires are trapped.

The transformer leads may be trimmed as desired for a neat job, but be sure you do not cut any of them too short (particularly if yours is the multi-voltage version, and any change to a different supply voltage is likely). Cutting the leads too short for re-use may void its warranty, if it is thought to be defective. Consult the multi-voltage diagrams elsewhere in this manual for connections to the terminal strips which may differ from the step-by-step instructions here.

Be sure all strands of each transformer lead are tinned and soldered together before connection to a lug, so that there is no possibility of a stray strand touching anything but the lug.

- 39 Select the remaining spade lug, and solder it to the black transformer lead. Connect it to the PS left lug.
- 40 Select the .005 (502M) disc capacitor, and trim its leads to 1/2" or less. Wrap one lead around the shaft of the spade lug which is connected to the PS left (inside) lug. Wrap the other lead around the shaft of the spade lug connected to the middle lug. Solder both leads. Be sure there is adequate clearance between these connections, and that the spade lugs are fully engaged.
- 41 Connect the black/white transformer lead to TS lug #5. (S3). One of these wires was previously soldered to the lower hole of this lug.
- 42 Twist together the two red transformer leads for neatness, and connect one lead to DB lug #2. Connect the other to DB lug #3.
- 43 Select the .01 mfd (103M) disc capacitor, and trim its leads to 3/4" Strip two 1/2" pieces of insulation from the green wire, and slide one piece over each of the capacitor leads. Connect one lead to DB lug #2. (S-2) Connect the other lead to DB lug #3. (S-2) Make sure both leads are securely soldered to each lug. Here you could overlook a poor connection.
- 44 Connect the red/yellow transformer lead to the center of the bare wire between the capacitor lugs. (S). Lowest hum in the unit will be attained when all of the wires which connect here are as close to the center of this wire as possible.
- 45 Connect the **single** green wire from output terminal LB to the center of the bare wire next to the transformer lead. (S).
- 46 Connect the **single** green wire from RB to the center of the bare wire on the other side of the transformer lead. (S).
- 47 Connect the green wire from CL lug #3 between the two input sockets to the center of the bare wire also. (S).
- 48 Select the output assembly modules (the two major items in the kit). You will note that the only difference, which identifies the left or the right module, is the position of the thermal breaker, which is located between one pair of output transistors on the heat sink rib. Before connecting wires to these modules it is best that you take the time to inspect the underside of the bottom row of holes to make certain that connections already made to some of these are well soldered. You will be making connections from the top side to holes 3,5,6,7,8 and 10. Make sure the proper connection point is clear at each of

these. If it is filled with solder, running the iron along the underside will uncover the hole, and it may be cleared with a wooden toothpick.

Now position the right module (with the breaker at the front when the long bottom row of eyelets is next to the chassis) with the circuit board **up**, against the side of the chassis.

Wires will be connected to the holes from the top of the board, and you must be sure they are soldered securely to the bright circuit 'pads'. Each hole is 'plated through' – it makes a connection to the other side of the board – and a good solder connection which heats the wire and the circuit pad properly will allow solder to flow through the hole for a secure connection.

Even though the connecting wires are just long enough to make the connections now, they will be rather long when the amplifier is completed. That is why working room is limited. Any wire which is to be connected to a hole on the board should have a tight, tinned end. The wire supplied in the kit is already tinned, so it would not normally require additional tinning unless the tip is frayed. Melt a small amount of solder on the tip of the iron so that it will make a good contact with both the bared wire end, and the circuit pad as the wire is inserted into the hole. Then add additional solder so that there is a smooth, bright transition from the wire to the board as it cools undisturbed. If you must use a great deal of heat on a connection, make sure that you have not loosened any adjacent connections in the process – especially wires from the back side of the board.

The holes #10 and #3 are very close to capacitors on the board. Be sure heat does not damage these capacitors.

- 49 Prepare a 5 1/2" green wire. Connect one end to hole #10 on the circuit board. (S). Make sure it **cannot** contact the transistor mounting screw near the underside. Connect the other end to FR lug #2 (S).
- 50 Prepare a 6" white wire. Connect one end to hole #3. (S). Connect the other end to FR lug #4. (s).
- 51 Select the green and white twisted pair from the output terminals RR and RB. Connect the white wire to hole #5. (S). Connect the green wire to hole #7 (S).
- 52 Select the pair of white wires from RF. Connect the shorter wire to hole #6. (S). Connect the other wire to hole #8. (S).
- 53 Select 4 of the long sheet metal screws. Take care to see that no wires are trapped in the process, while you tilt up the module and fasten it to the end of the chassis. The screws are inserted between the heat sink fins, and then engage the chassis.
- 54 Select the green and white pair of wires from input socket RS. Connect the white wire from the left to the top (rear) hole #1. (S). Connect the green wire to hole #2. (S). These wires should be soldered to the circuitry on the underside of the board, although they are connected from the top side of the board, assuring a good connection. These wires will be specifically positioned later, though they now seem long.

- 55 Select the white pair of wires at the front of the chassis. Tuck the excess-wire into the corner and connect one wire to each of the lugs on the thermal breaker. Solder each.
- 56 Select the left output module, check it as before to see that underside connections near the holes are secure, and that the holes are visible. Place it against the left side of the chassis with the breaker at the front, board up.
- 57 Prepare a 6" green wire. Connect one end to hole #10. (S). Be sure it cannot touch the transistor mounting screw! Connect the other end to FL lug #2. (S).
- 58 Select the green and white pair from output terminals LB and LR. Connect the green wire to hole #7. (S). Connect the white wire to hole #5. (S).
- 59 Select the white pair from LF. Connect the shorter wire to hole #8 (S). connect the other wire to hole #6 (S).
- 60 Prepare a 5 1/2 white wire. Connect one end to hole 3. (S). Connect the other end to FL lug #4. (S).
- 61 Select 4 sheet metal screws and fasten the module to the chassis, making sure no wires are trapped.
- 62 Select the green and white pair from input socket LS. Connect the green wire to the top rear hole #2. (S). Connect the white wire to hole #1. (S). Solder these on the back of the board.
- 63 Tuck the excess of the remaining white pair of wires into the front corner, and connect one wire to each lug of the thermal breaker. Solder each.
- 64 Select the 7 ampere slo-bid fuse (a slo-bid fuse has distinctive internal construction) and install it in the single fuse clip FC.
- 65 Select four 5 amp regular fuses, and install them in the dual fuse clips FL and FR.
- 66 Select the two 2 amp fuses, and install them in the twist type fuse holders on the back panel. These fuses will provide reasonable protection for most speakers. See the Operation section of this manual for more detailed information. The remaining 5 amp fuses are alternates for the back panel holders for high power test purposes.
- 67 For lowest distortion performance and lowest noise, correct placement of some wires is important. The wires from the output terminals and the back panel fuse holders should be kept against the chassis. The input socket pairs should be about an inch above the chassis, (the left pair can be tucked under the rear chassis lip), and should turn upwards at the bottom center of the circuit board, about 1/2" to 1" off the board, in the plane defined by the edges of the finned heat sinks. The wires to the dual fuse clips should be kept away from the board and against the chassis, bringing the excess length forward of the fuses. The leads to the power supply capacitors should be kept away from the boards. The

green ground leads from the black output terminals and the ground lug should be brought together through most of their length.

- 68 Check all your soldered connections – especially those on the fuse clip lugs, which are sometimes difficult to solder to. Clip off any excess bare wire which could short to adjacent lugs or the chassis. Pay particular attention to the stranded wires from the transformer and line cord, and check the power switch connections. Now turn the amplifier upside down and shake out any bits of wire or solder.
- 69 Slide the cover in place, and install it with the eight sheet metal screws.
- 70 Remove the backing from the serial number label, and apply it to the bottom at the center rear. (This may have already been done at the factory.)

IF PROBLEMS ARISE

Each circuit module, which comprises all the “active” amplifier circuitry, has been incircuit tested to standards identical to factory built amplifiers, prior to being packed in a kit. Thus, with careful assembly, the likelihood of a circuit fault is near zero. If you are certain the problem lies in the power amplifier, check the pilot lamp. If it is blinking, excessive temperature has shut down the amplifier. After a few minutes to cool, it will turn on automatically. If it soon shuts down again, and the amplifier has sufficient ventilation, the malfunction is either internal, or the result of an excessive (and very likely inaudible) input signal. In that case, the source must be investigated.

If the pilot lamp is not lighted, the main fuse in the single fuse clip near the power switch is probably open. If a replacement 7 ampere Slo-Blo fuse (do not use a larger value) also blows, the amplifier has a power supply problem, and requires professional service.

If there is a problem in only one channel of the amplifier, that channel may be isolated by removing the power supply fuses in the adjacent dual fuse clip, and the other channel may be used monophonically. We do not encourage local service of this amplifier because some components may not be available locally, and substitutions are not recommended at all. You may return a defective module for factory service. This reduces shipping weight and the likelihood of damage. To remove the module (leave the heat sink attached to the circuit board) tag each wire with the circuit board hole number as you unsolder it from the board, and **insulate** each bare wire end. It is safer to also remove the power supply fuses from that channel. The wires to the thermal breaker must be temporarily **soldered together**, and insulated.

Adjustments for Bias and DC Offset

These two potentiometers on each circuit board have been set at the factory and should not normally require adjustment for the life of the amplifier. In the event of repairs such as transistor replacement, the following is the procedure, after removing all input and output connections to the amplifier.

Bias

Remove the B + fuse F2. This fuse is in the line from the '+' capacitor terminal to hole #3 on the board. Connect an ammeter's '+' lead to the fuse clip nearest the large filter capacitors. Connect the '-' lead to the other side of the fuse clip. Avoid intermittent connections, and do not short the leads together. Turn the amplifier on, and if possible adjust the line voltage to 120 volts. Adjust P2, near the middle of the board, to 275 mA. Turn the amplifier off, and when the current drops to zero, then remove the ammeter and replace the fuse.

Offset

A DC voltmeter capable of resolving 10 mV variations is needed. Connect it to the output terminals of the selected channel, and adjust P1, near the top of the board, to zero volts, + 10 mV. A small correction of the control will produce a large initial change, which will settle down in a second. Repeat these small changes to achieve zero volts.

SERVICE POLICY AND LIMITED WARRANTY

The DH-220 Power Amplifier has been carefully engineered to provide many years of use without requiring any maintenance or servicing.

Factory assembled units are subjected to several physical and electrical tests before shipment. The output circuit board assemblies of kit units are similarly tested prior to shipment. In spite of all this testing, shipping damage does occur, kits are not assembled properly or someone "goofs" and service and/or maintenance will be required. The David Hafler Co. provides complete service facilities at the factory to make any necessary repairs.

It is the owner's responsibility *to return or ship the unit freight prepaid to the factory service department. Units shipped freight collect will not be accepted. For units to be repaired under warranty a copy of the dated bill of sale must accompany the unit.*

Shipment should be via UNITED PARCEL SERVICE. Parcel Post is not a safe way to ship electronic equipment. The factory will not be responsible for damage caused by parcel post shipment and repairs will be made at the owner's expense. When shipping your DH-220 be sure to insure it for the full value of an assembled amplifier.

Use the original carton and packing material to ship your amplifier. Enclose with the unit the following information:

1. Complete shipping address (Post Office Box numbers are often not acceptable.)
2. The serial number.
3. Copy of dated bill of sale if repairs are to be made under warranty.
4. Description of the malfunction. If intermittent, please note.
5. We also suggest further identifying the unit as yours by putting a label on the bottom or tying a label with your name and address on the line cord.

All service work is guaranteed for 90 days.

Warranties apply to the original purchaser only. Warranties are void if: a) the amplifier has been either physically or electrically abused or used for some purpose for which it was not designed, or b) the amplifier has been modified without factory authorization.

The transformer warranty is void if the leads have been cut too short for reuse. If you think a transformer is defective the leads must be unsoldered, not cut, for its return.

Technical assistance to help you locate the source of a problem may be obtained by calling the Technical Services Department at 609-662-6084, 8 a.m.-4:30 p.m. E.T. It is helpful to know the serial number of the unit and the results of any tests you have performed.

SERVICING AN AMPLIFIER MODULE

If you are certain that the problem is confined to one of the amplifier modules (comprising the circuit board, heat sink, and output transistors), you may remove and return only the module for service. Be sure that the components on the circuit board are well protected – as by a surrounding sleeve of corrugated cardboard which rests against the heat sink, and projects beyond the components. Properly packed and insured for \$150, this assembly can be sent by parcel post, as well as UPS, if necessary. A service fee of \$20 must be sent with every module, since the fault may have been caused by a wiring error elsewhere. For this reason, too, and because we have no control over its proper reinstallation, the service warranty on a separate module is limited to assurance of its proper functioning when it leaves the service facility. All modules are tested before being returned to you. If you believe the fault is the factory's warranty responsibility, include the serial number and the *bill of sale*. If in our judgement the fault is entirely a manufacturing defect, a portion of the service fee will be refunded. Only a complete amplifier can be fully checked and given a service warranty.

WARRANTY FOR KIT-BUILT UNITS

The parts in a DH-220 kit are warranted for a full year from the purchase date. If a defective component is found on a circuit board or in a kit, simply return the *individual* part to the factory prepaid together with the serial number and the date of purchase, and it will be replaced at no charge.

If you cannot locate what is wrong with your DH-220, return it to the factory with a copy of the dated bill of sale, and a check for \$40. If the sole cause of the problem is a defective part, the unit will be repaired and returned to you transportation prepaid, and your \$40 *less a charge for repackaging and shipping* will be returned to you. If the problem is found to be an error in your assembly of the amplifier, the amplifier will be put in proper working order, tested to be sure it is meeting specifications, and returned to you (freight prepaid within the continental U.S.). Excess shipping charges for expedited service, or overseas delivery are your responsibility. At the sole discretion of the factory service department, if the time required for diagnosis, repair and testing, and the nature of the malfunction warrants it, a portion of the submitted repair fee may be rebated.

This warranty is void if the kit has not been completely assembled or if other than rosin core solder has been used. Units assembled with acid core solder or paste flux will be returned unserviced.

WARRANTY FOR FACTORY ASSEMBLED UNITS

The DH-220 is warranted for three years from the purchase date including parts and labor and normal shipping costs from the factory to the owner within the continental U.S. The owner is responsible for returning the unit to the factory and must submit a copy of the dated bill of sale.

This warranty gives you specific legal rights. You may also have other rights which vary from state to state.

AC LINE CONNECTIONS FOR OVERSEAS USE

The power transformer supplied in DH-220 amplifiers sold in the IJSA is intended for 120 volt, 60 Hz operation only. For use in other countries, a multi-voltage transformer is available at higher cost. It has dual tapped primary windings which can be arranged in various series-parallel combinations for 100, 110, 120, 200, 220 and 240 volt 50 or 60 cycle AC mains. The schematic diagram details the wiring combinations which are represented pictorially here.

Note that a separate 2-lug terminal strip is required when the multi-voltage transformer is used. This is supplied in kits which include the special transformer. If the amplifier is operated with 200 to 240 volt lines, the 7 amp line fuse which is supplied should be replaced with a 4 amp Slo-Blo type fuse.

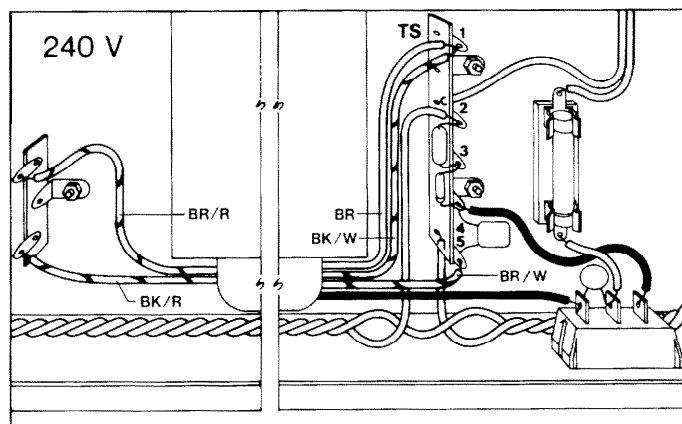
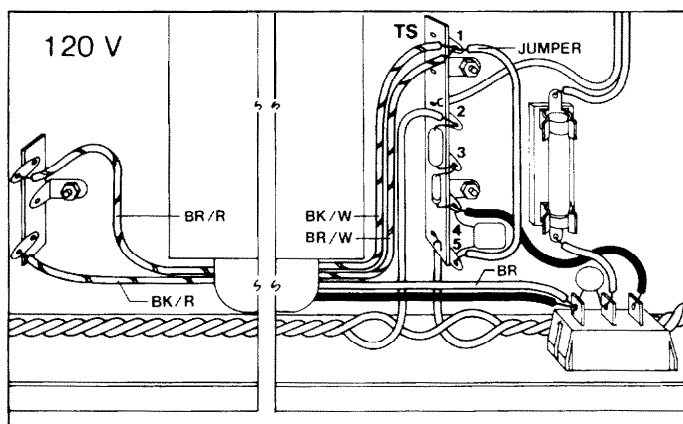
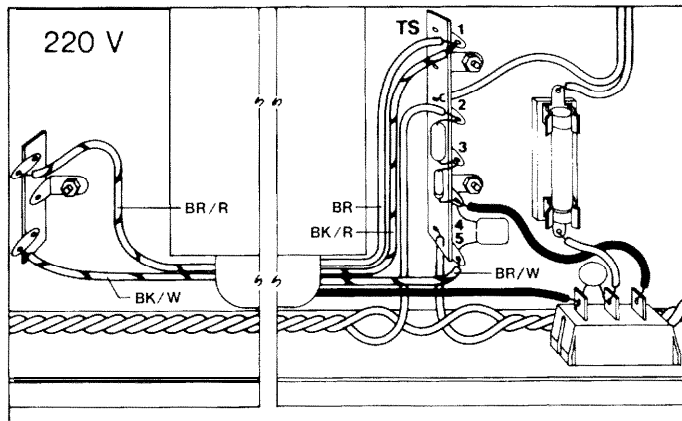
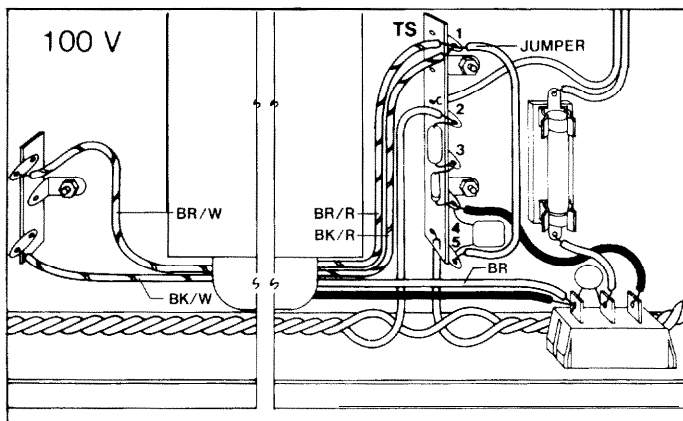
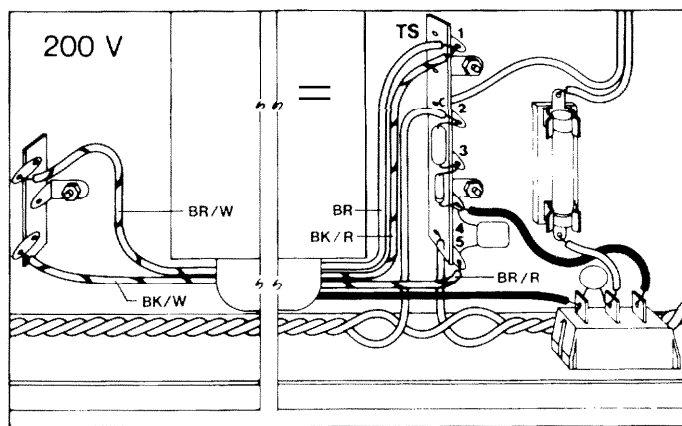

VOLTAGE CHART

measured with 120 volt line, no signal. with respect to the ground buss between the two capacitors in the power supply.

	E	B	c		E	B	c		s	G	D
Q1	62.6	62.1)	0.88	Q8	63.0	62.0	1.54	Q401	0	1.0	65.4
Q2	-62.6	-62.0	-0.37	Q9	-1.27	-0.6	1.54	Q402	0	1.0	65.4
Q3	-0.32	0.22	61.8	Q10	-63.0	-62.0	0	Q403	0	-0.8	-65.4
Q4	-0.32	0.22	61.8	Q11	-63.0	-62.0	-1.35	Q404	0	-0.8	-65.4
Q5	0.8	0.22	-62.0	Q12	1.0	1.54	65.0				
Q6	0.8	0.22	-62.0	Q13	-0.8	-1.35	-65.0				
Q7	63.0	62.0	0								

Minor variations may sometimes be encountered in value or appearance. These will not affect performance.

Fuse Envelope

6 Fuse, 5 ampere	Part No.
2 Fuse, 2 ampere	SF012
1 Fuse, 7 ampere, Slo-Blo	SF01 1
1 Additional fuse, 4 ampere, Slo-Blo (International use only)	SF02 1
	SF026

Hardware Envelope

1 Lug, solder type, internal tooth, #6	Part No.
4 Lug, solder type, #10	HZ1 15
3 Lug, spade, 1/4"	HZ1 16
12 Nut, #4-40 KEP	xzo14
11 Nut, #6-32 KEP	HK111
4 Nut, #10-32 KEP	HK112
2 Nut, 1/2", for fuse holder	HK113
12 Screw, machine, #4 x 5/16"	HA1 18
10 Screw, machine, #6 x 1/2"	HA1 19
4 Screw, machine, #10 x 1/2"	HA1 17
4 Screw, #10 x 1/4", SEMS	HA1 18
16 Screw, sheet metal, #6 x 1/2"	HP1 18
1 Screw, machine, #6 x 3/4"	HA1 15
4 Washer, flat, 7/8"	HW114
2 Washer, locking, internal tooth, 1/2" for fuse holder	HW116
2 Washer, rubber, 1/2", for fuse holder	HRI17

Small Parts Envelope

1 Capacitor, .01 mfd, disc (103M)	Part No.
1 Capacitor, .005 mfd, disc (502M)	CZ113
1 Capacitor, .39 mfd	CE1 17
1 Diode	QD115
1 Label, serial number	LR015
1 Resistor, 1 megohm	RD113

	Part No.
1 Chassis	MS149
1 Cover	MS152
2 Capacitor, 10,000 mfd, 75V	CL121
2 Bracket, round, for capacitor	HZ125
1 Diode rectifier block	QD111
4 Feet, rubber	HR149
2 Fuse holder, round	XA013
1 Fuse clip, single	XA012
2 Fuse clip, dual	XA014
2 Input socket	XPO14
1 Line cord, with plug	WA016
2 Output module assembly (1 each, left & right)	AH326
2 Output terminal, black, with hardware	XK011
2 Output terminal, red, with hardware	XK012
1 Power switch	SL111
1 Strain relief, plastic	HR144
1 Terminal strip, 5 lug	XK018
1 Additional 2 lug terminal strip (International use only)	XK016
1 Power transformer	TA123
1 Alternate transformer (International use only)	TA124
1 Wire, white, #18	WS024
1 Wire, green, #18	wso22
1 Registration card	LM016

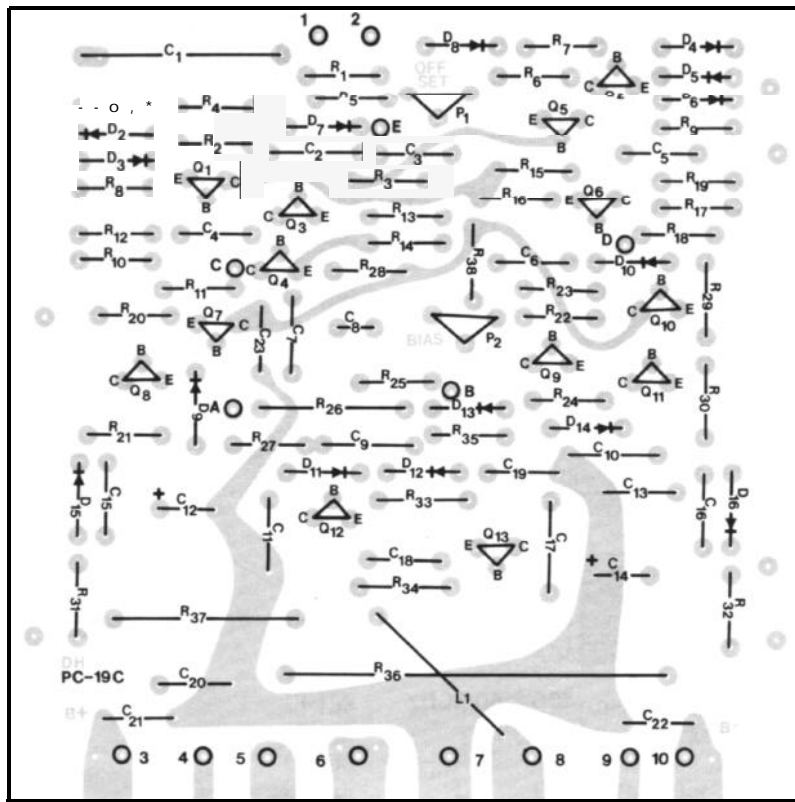

VIEWED FROM
COMPONENT
SIDE

PC-19C RIGHT CHANNEL

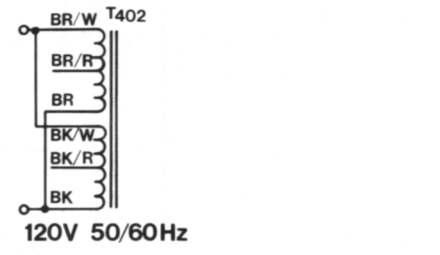
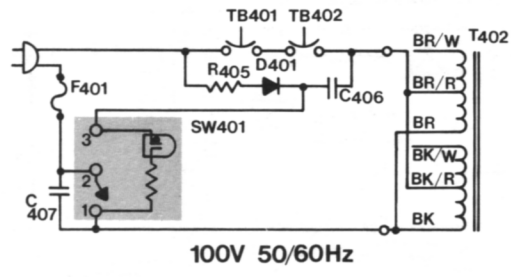
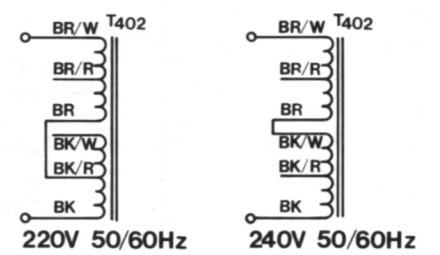
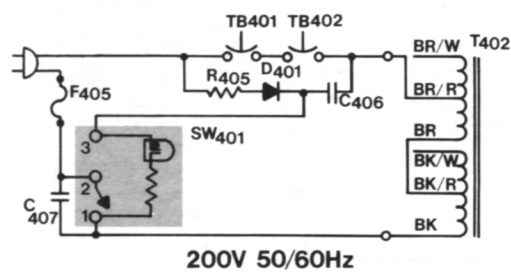
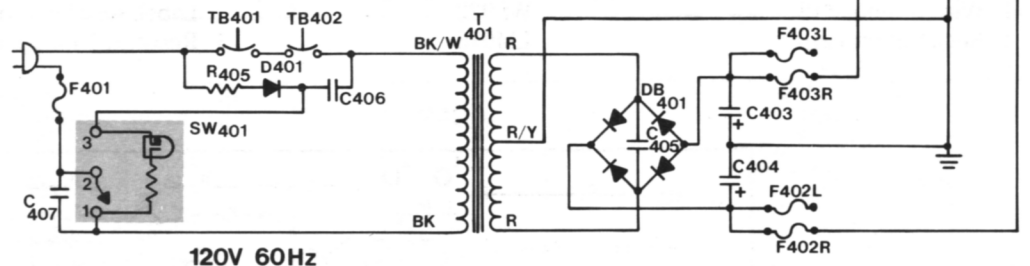
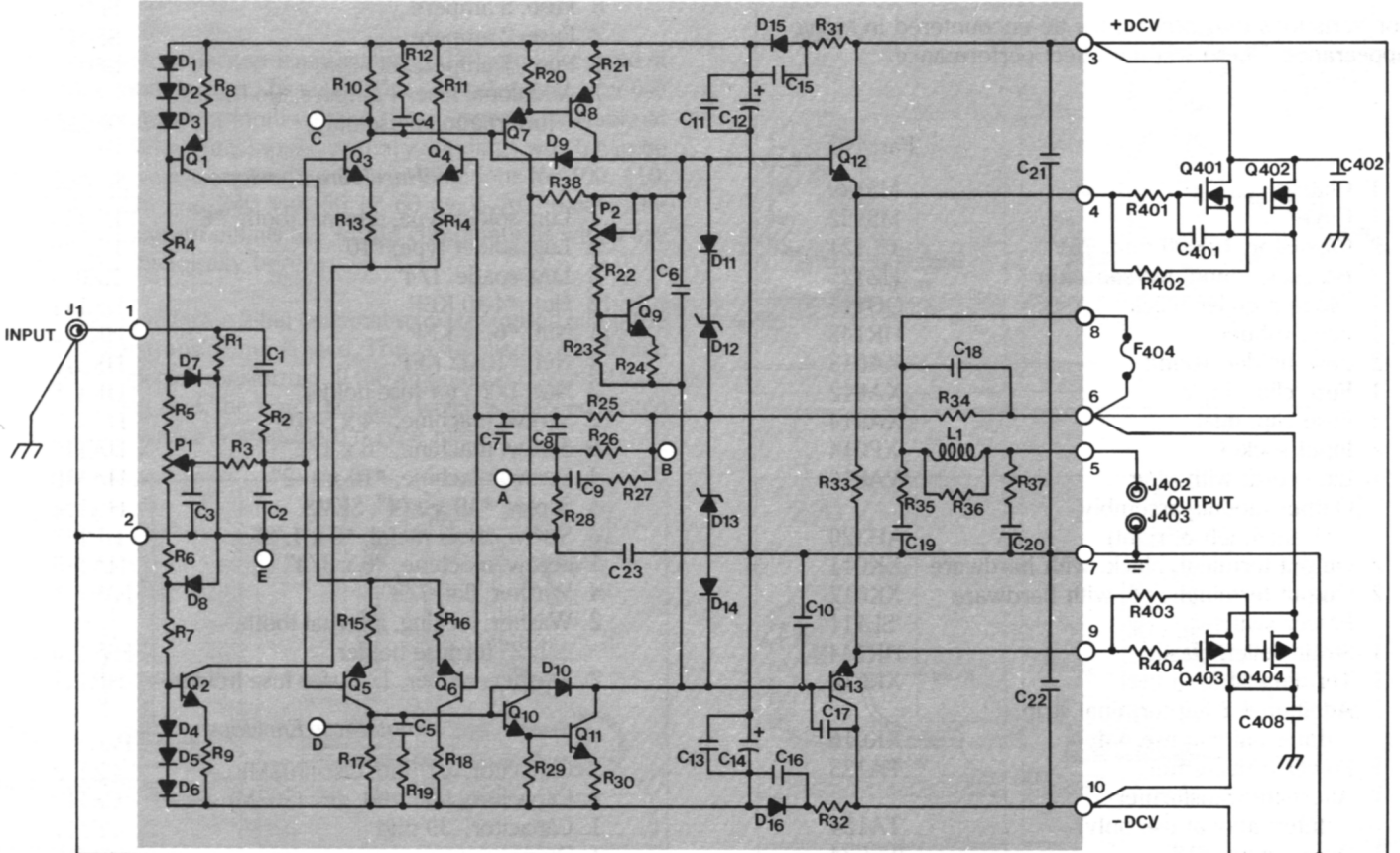

**SCHEMATIC
DIAGRAM**

© COPYRIGHT 1985
ALL RIGHTS RESERVED

All resistors are 1/4 w carbon film unless specified otherwise

		Part No.			
R1	470,000 ohms	RC044	C21	0.1 mfd, 100V, Film	CC125
R2	1,800 ohms	RC023	C22	0.1 mfd, 100V, Film	CC125
R3	47,000 ohms	RC043	C23	.001 mfd, 250V, Film	CP136
R4	47,000 ohms	RC043	C40 1	680 pF, 500V, Mica	CM121
R5	1,000 ohms	RC015	C402	0.1 mfd, 100V, Film	CE115
R6	1,000 ohms	RC015	C403	10,000 mfd, 75V, Electrolytic	CL121
R7	47,000 ohms	RC043	C404	10,000 mfd, 75V, Electrolytic	CL121
R8	560 ohms	RC045	C405	.01 mfd, 1000V, Disc	CZI 12
R9	560 ohms	RC045	C406	.39 mfd, 100V, Polyester	CE117
R10	1,800 ohms	RC023	C407	.005 mfd, 1000V, Disc	cz113
R11	1,800 ohms	RC023	C408	0.1 mfd, 100V, Film	CE115
R12	270 ohms	RC029	D1	IN4 148 Diode	QD116
R13	47 ohms	RC039	D2	IN4 148 Diode	QD116
R14	47 ohms	RC039	D3	IN4 148 Diode	QD116
R15	47 ohms	RC039	D4	IN4 148 Diode	QD116
R16	47 ohms	RC039	D5	IN4 148 Diode	QD116
R17	1,800 ohms	RC023	D6	IN4 148 Diode	QD116
R18	1,800 ohms	RC023	D7	IN4 148 Diode	QD116
R19	270 ohms	RC029	D8	IN4 148 Diode	QD116
R20	1,800 ohms	RC023	D9	FDH-400 Diode	QD121
R21	82 ohms	RC053	D10	FDH-400 Diode	QD121
R22	560 ohms	RC045	D11	IN4 148 Diode	QD116
R23	470 ohms	RC04 1	D12	IN5240B 10V Zener Diode	QD111
R24	10 ohms	RC013	D13	IN5240B 10V Zener Diode	QD111
R25	33,000 ohms	RC036	D14	IN4 148 Diode	QD116
R26	3,300 ohms, 1W, metal film	RZo13	D15	IN4003 Diode	QD115
R27	1,000 ohms, 1/4W, metal film	RMo21	D16	IN4003 Diode	QD115
R28	150 ohms, 1/4W, metal film	RM013	D40 1	IN4003 Diode	QD115
R29	1,800 ohms	RC023	DB40 1	Diode Bridge, 25A	QD117
R30	82 ohms	RC053	P1	1,000 ohms trimpot	RPO11
R31	47 ohms, 1/4W, carbon comp.	RZO11	P2	1,000 ohms trimpot	RPO11
R32	47 ohms, 1/4W, carbon comp.	RZO11			
R33	220 ohms, 1/2W	RD114			
R34	2,200 ohms, 1/2W	RD115	F401 7A,	Slo-Blo MDX	SF02 1
R35	10 ohms	RC013	F402 5A,	3 AG	SF012
R36	1 ohm, 10W	RW012	F403 5A,	3AG	SF012
R37	10 ohms, 5W	RW013	F404 2A,	3AG (size optional)	SF01 1
R38	28,000 ohms, 1/4W, metal film	RM053	F405 4A,	Slo-Blo MDX	SF026
R40 1	470 ohms, 1/2W	RD117			
R402	470 ohms, 1/2W	RDI 17	T40 1	Power Transformer, Domestic	TA123
R403	220 ohms, 1/2W	RD114	T402	Power Transformer, International	TA124
R404	220 ohms, 1/2W	RD114			
R405	1 meg ohms, 1/2W	RDI 13	Q2	2N5401	QP122
C1	2 mfd, 50V, Film	CP115	Q3	2N5550	QN128
C2	330 pF, 630V, Film	CP134		2N5550	QN128
C3	.01 mfd, 250V, Film	CP135	Q4	2N5550	QN128
C4	.001 mfd, 250V, Film	CP136	Q6	2N5401	QP122
C5	.001 mfd, 250V, Film	CP136	Q7	2N5402N540	QP122
C6	0.1 mfd, 100V, Film	CC125	Q8		QP122
C7	0.1 mfd, 100V, Film	CC125	Q9	2N5415	QP123
C8	470 mfd, 1 OV, Non-polar Electrolytic	CN113		NP2222	QN124
C9	150 pF, 630V, Film	CP133	Q10	2N5550	QN128
C10	330 pF, 630V, Film	CP134	Q11	2N3440	QN125
C11	.01 mfd, 250V, Film	CP135	Q 1 2	2N3440	QN125
C12	100 mfd, 100V, Electrolytic	CL122	Q 1 3	2N5415	QP123
C13	.01 mfd, 250V, Film	CP135	Q401	2SK134	QN112
C14	100 mfd, 100V, Electrolytic	CL122	Q402	2SK134	QN112
C15	.01 mfd, 250V, Film	CP135	Q403	2SJ49	QP112
C16	.01 mfd, 250V, Film	CP135	Q404	2SJ49	QP112
C17	150 pF, 630V, Film	CP133			
C18	.01 mfd, 250V, Film	CP135	TB40 1	Thermal Breaker	SF024
C19	.01 mfd, 250V, Film	CP135	TB402	Thermal Breaker	SF024
C20	0.1 mfd, 100V, Film	CC125	L1	Output Inductor	TA112

SPECIFICATIONS

Power Rating: Less than 0.02% total harmonic distortion at any power level up to 115 watts continuous average power per channel into 8 ohms at any frequency between 20 Hz and 20 kHz with both channels driven.

IM Distortion (SMPTE) Less than 0.008%, from 1 watt to 115 watts into 8 ohms.

Typical THD at 115 watts into 8 ohms:

1 kHz — 0.0025%
10 kHz — 0.007%
20 kHz — 0.012% /'

Frequency Response into 8 ohms:

- 3 dB, 2 Hz to 160 kHz at 1 watt
+0, -0.5 dB, 6 Hz to 60 kHz at 115 watts

Typical Channel Separation: 20 Hz: > 75 dB
1 kHz: > 85 dB
20 kHz: > 65 dB

Signal to Noise Ratio, unweighted: Better than 100 dB at 115 watts into 8 ohms.

Input Impedance: 47,000 ohms.

Input Sensitivity: 1.55 volts rms for 115 watts into 8 ohms.

Damping Factor: 300 to 1 kHz into 8 ohms
60 to 10 kHz into 8 ohms

Rise Time: 10 kHz, 60 volts peak to peak square wave, 10% to 90% 2.5 us.

Slew Rate: 10 kHz, 60 volts peak to peak square wave: 30 V/μs.

Semiconductor Complement: 26 transistors, 8 power Mosfets, 29 diodes, 4 zener diodes, 1 diode bridge.

Power Consumption: 115 watts into 8 ohms: 840 VA;
Quiescent: 125 VA.

Size: 5-1/8" high, 16" wide, 10-1/2" deep.

Net Weight: 26 lbs.

Shipping Weight: 30 lbs.

All Specifications are subject to change without notice.



Printed in USA

HAFLER DH-220 STEREO POWER AMPLIFIER

PICTORIAL DIAGRAM

© Copyright 1984, All rights reserved.

LM 096

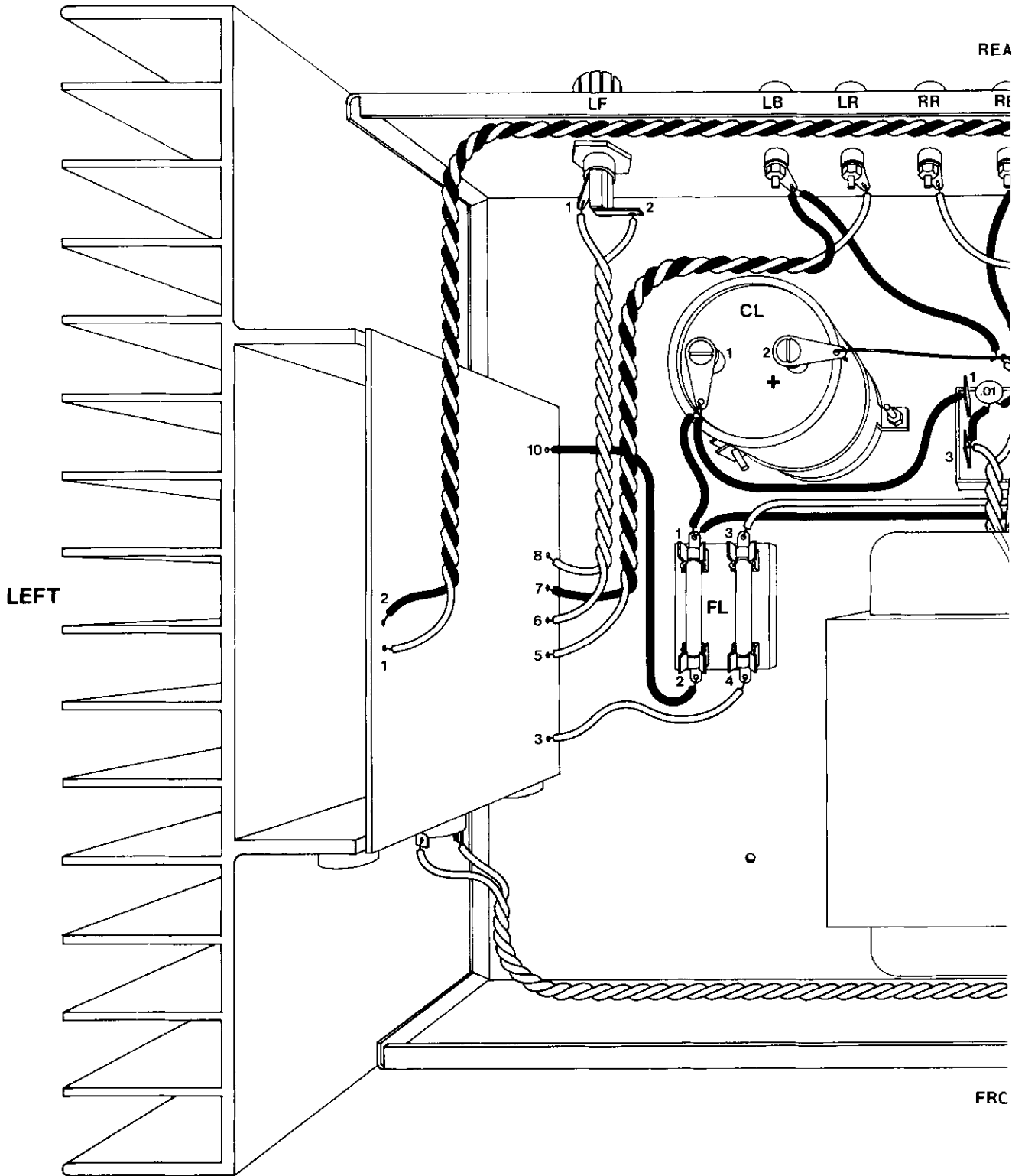

inches

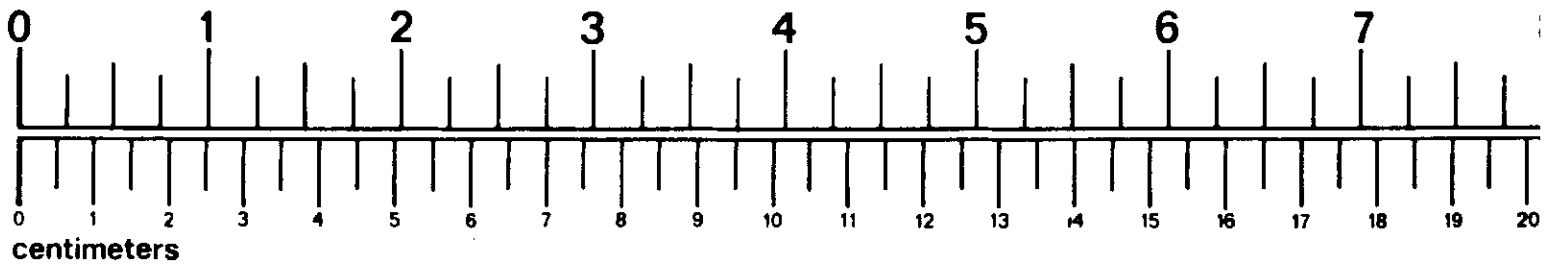

centimeters

REAR

RB LS GL RS RF AC

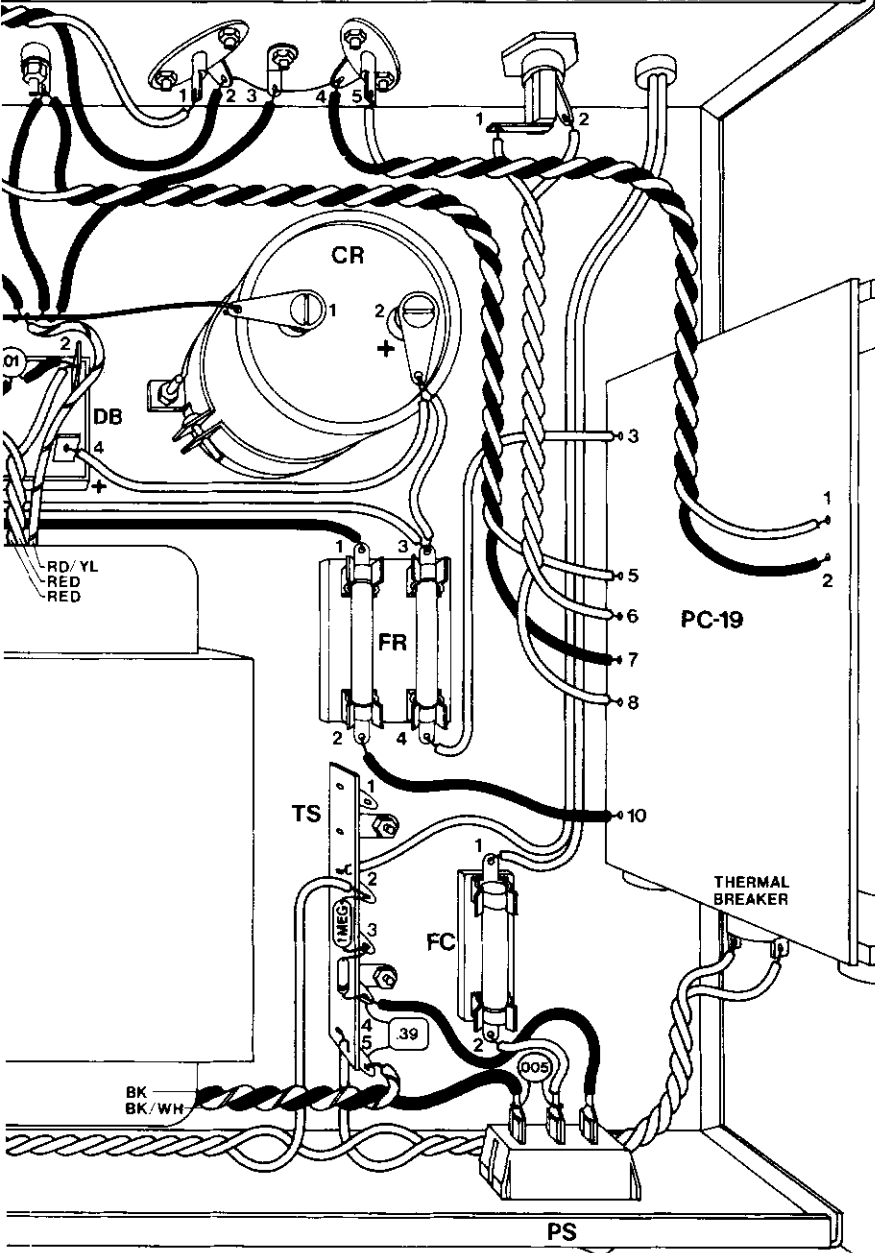

PC-19

RIGHT

THERMAL BREAKER

PS

FRONT

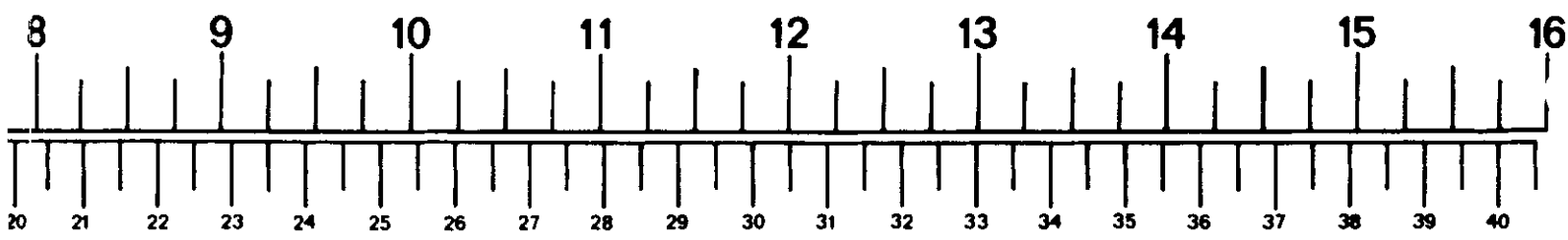

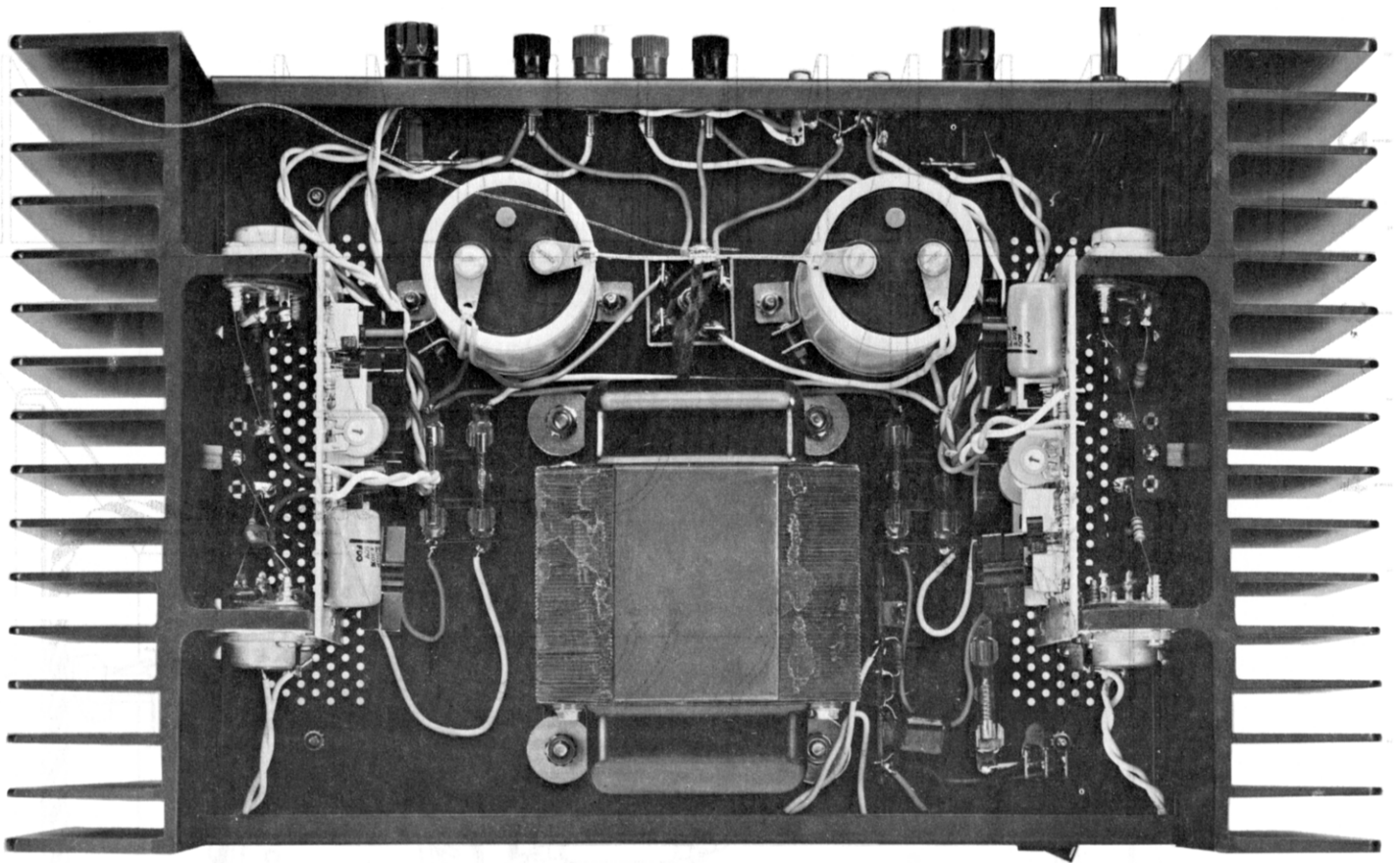
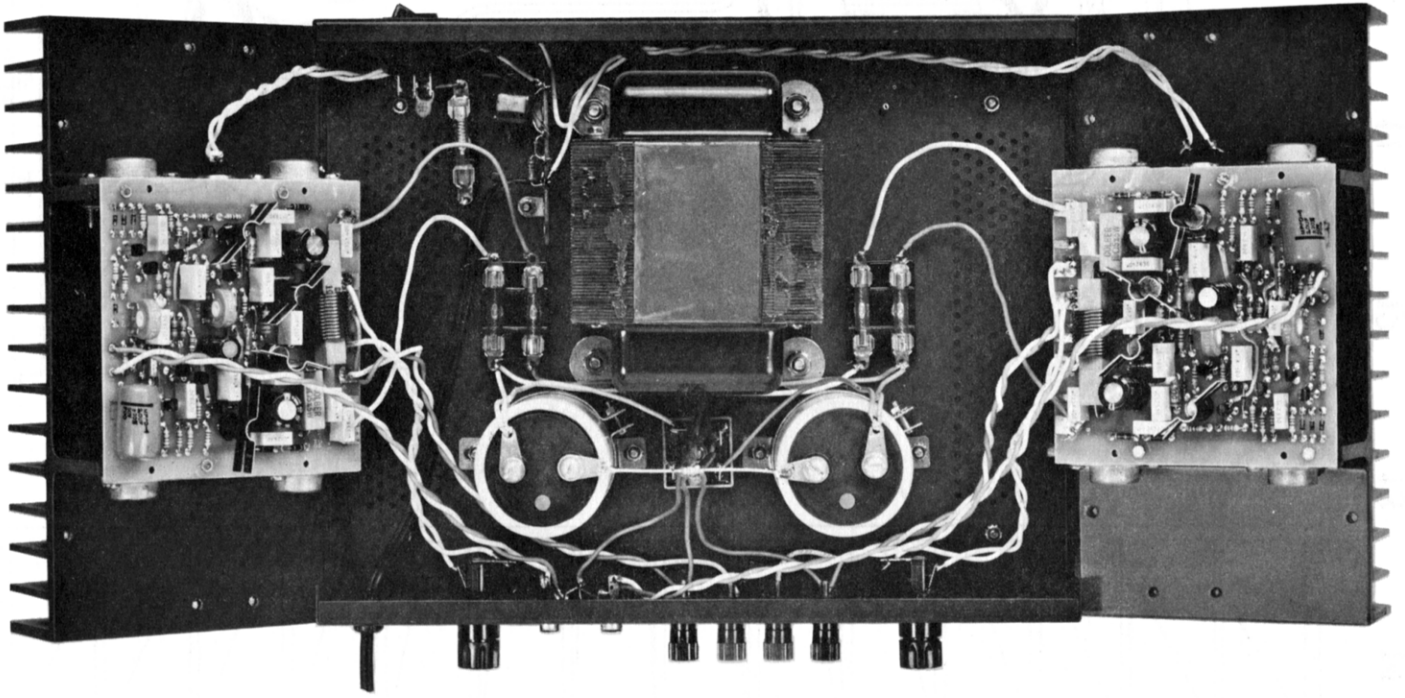

INSTRUCTIONS FOR THE HAFLER AMPLIFIER BRIDGING KIT FOR THE DH-220

The DH-222 may be installed in a Hafler DH-220 power amplifier to enable easy conversion to a high power monophonic amplifier, bridging the two conventional channels to a single floating output which can deliver in excess of 400 watts into an 8 ohm load. Its rated power output is 350 watts across the audio band.

When switched to monophonic operation (UP), signal input should be provided to the LEFT input jack only, and the output should be connected only to the two center BED (+) terminals. No connection of the load is to be made to the black output terminals. Because of the floating output, neither side of the load may be grounded. Thus it is unlikely that stereo speaker switching boxes, or headphone adapters may be used, as these often have a common ground between the left and right channels.

The speaker fuses may be replaced with higher values than the 2-5 ampere range suggested for stereo operation, if desired, depending on the degree of protection for the speaker which is intended. The graph shows the nominal sustained power output limit of a 7 ampere standard fuse, which is the maximum recommended value. Smaller values will provide more protection for the speakers; larger ratings are at the user's risk.

Both speaker fuses should be the same value. If one speaker

fuse blows in mono operation, both should be replaced, for it is likely that the second has been weakened. For equivalent load impedance, each speaker fuse provides the same power output protection as in stereo operation.

With the internal conversion switch DOWN, the amplifier functions as a conventional stereo amplifier, with normal input and output connections. The minimum recommended load impedance, which is limited only by thermal factors (ability of the heat sinks to dissipate high energy levels), is 6 ohms in mono; the usual 3 ohms in stereo. The amplifier circuit can safely accommodate lower impedance loads, of course.

The conversion, which takes less than an hour, involves only changes to the input wiring, and installation of the switch with its mounting bracket and one resistor. These instructions assume familiarity with the usual kit building descriptions, and reminders. For more details in this regard, see the construction section of your DH-220 amplifier manual. You must be certain you have made a good solder connection wherever one is called for, not only to the wire you have attached, but to any others already connected to that point. The notation (S) indicates a soldered connection; (S-2) denotes that there are two wires to be soldered. Use only 60/40 rosin core solder. Be careful not to let the soldering iron touch adjacent components on the circuit board: excessive heat could change their operation, with the possibility of damage to the amplifier.

KIT PARTS LIST

1	Switch, DPDT	sz114
1	Mounting bracket	MS183
1	Indexing washer	HW123
1	Lockwasher	HW122
2	Nut, switch mounting	HK125
2	Nut, 6-32 KEP	HK112
2	Screw, machine, 6-32	HA116
1	Resistor, 3000 ohms	RZ017
	Wire, red, 22 gauge	
	Wire, green, 22 gauge	
	Wire, black, 22 gauge	

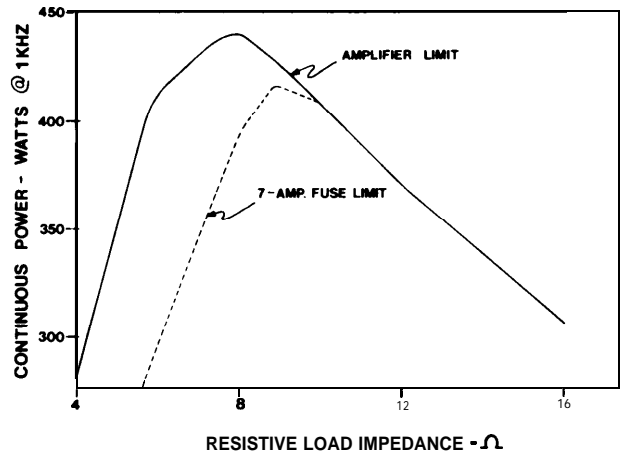

LIMITED WARRANTY

The parts in the DH-222 are guaranteed against defects for one year from the date of purchase. Installation in a DH-220 amplifier is the owner's responsibility. In the event of difficulty with the completed unit, charges for service, if any, will be in accordance with the warranty provisions for the amplifier, if it was purchased as a kit. If it was purchased as a factory assembled unit, there is the further stipulation that faults incurred as a result of improper installation of the DH-222 are the owner's responsibility, but in other respects the original warranty applies. This warranty gives you specific legal rights. You may also have other rights which vary from state to state.

THE **DAVID HAFLER** COMPANY

5910 CRESCENT BOULEVARD, PENNSAUKEN, NJ 08109.609/662-6355

DH-222 INSTALLATION INSTRUCTIONS

- 1 Disconnect AC power from the amplifier, and remove all connecting cables. Wait 5 minutes to allow capacitors to discharge before proceeding with disassembly.
- 2 Remove all 8 screws between the fins of each amplifier module so that the cover may be removed, and the modules tilted outwards for easier access.
- 3 Unsolder the pair of twisted wires connected to holes 1 and 2 at the top of the *right* channel PC-19 circuit board. The right channel is the one nearest the power switch. This pair must also be unsoldered from the right input socket on the back panel, because it will be more convenient to use lighter gauge wiring.
- 4 Prepare a 6" red wire, and a 6 1/2" black wire. Start with the black wire 1/2" longer than the red wire, and twist them together uniformly throughout their length. At the end where the black wire projects, connect it to the *short* lug of the right input socket. (S-2). Be sure the existing wire to the adjacent ground lug is properly connected. Connect the corresponding end of the red wire to the long lug of the input socket. (S). Place this pair off to the right edge.
- 5 Prepare a 5" red wire, and a 5" black wire. With the ends even, twist these together and connect the red wire to hole #1 at the top of the right channel PC-19 circuit board. (S) Connect the black wire to hole #2. (S).
- 6 Prepare a 20" green wire. Cut a 20" black wire, but remove the insulation from only one end. Starting with the bare end of the black wire 1/2" longer than the green wire, twist these together. At the far end, where the black insulation has not been removed, the black wire will not be connected, but instead will be secured by wrapping it in a tight circle around the green wire a short distance from the bare green end. It is very important that no bare wire be visible from the black insulation. The single green wire is to be connected near the center of the left circuit board to the hole designated "B", located just below the bias adjustment potentiometer. (S). It must be securely soldered, but be careful that you do not damage adjacent components.
- 7 Making sure that no wires are pinched between the module and the chassis in the process, reinstall the left module to the chassis with 4 sheet metal screws.
- 8 Select the switch and its 2 nuts, lockwasher and indexing flat washer, and the switch mounting bracket. Install one nut all

the way onto the switch collar, and follow it with the indexing washer with its lug projecting towards the handle lever. Mount the switch on the bracket so that the lever points in the direction of the bracket flange, and the indexing lug engages the locating hole in the bracket. Secure it with the lockwasher and the second nut.

- 9 Select the two machine screws and nuts, and install the switch bracket between the two transistors at the rear of the right module, so that the switch lever points towards the fins.
- 10 Select the 3000 ohm resistor and trim its leads to 1/2" Connect it between switch lugs #4 and #5. Solder only lug #5.
- 11 Select the red and black pair from the right input socket and connect the black wire to switch lug #3. Do not solder this connection yet. Connect the red wire to switch lug #1. (S).
- 12 Select the red and black pair from the right channel circuit board holes 1 and 2. Connect the black wire to switch lug #3. (S-2). Connect the red wire to lug #2. (S).
- 13 Select the green and black pair and separate the wires for about 1". Connect the green wire to right circuit board hole "A". (S). Connect the black wire to hole "E". (S). Hole "A" is located in line with the switch about 1 1/2" from the rear edge of the board. "E" is located 1/2" below hole 2, near the top of the board.
- 14 Place the green and black pair towards the rear of the module, and down past the midline of the switch. Where it passes lug #5, approximately the end of the wires, cut *only* the green wire. Strip each end 1/4" Connect the short green section to switch lug #4. (S-2): Connect the longer green wire from the left board to switch lug #6. (S).
- 15 Be careful no wires are pinched as you reinstall the right module to the chassis with 4 screws. Place the long green and black pair under the rear lip of the chassis. The pairs to the top eyelets on each board, and to the connections in the center of the board should be kept at least off the board, where they are clear of the components. Make sure the unconnected black wire end near the left circuit board cannot touch any components.
- 16 The switch lever should be placed in the upper position for monophonic operation. In the lower switch position, the amplifier functions as a conventional stereo amplifier. Reinstall the amplifier cover with the remaining 8 screws.

