

(The following resistors are metal film, 1/4W, 1% unless noted.)

| Part No. | Description   | Part No.       |
|----------|---|----------------|
| J1-J12   | Jack, RCA phono type, single circuit                    | XP015          |
| Q1,101   | J112 muting FET   | QN131          |
| R1,101   | 47.5 K ohms   | RM036          |
| R2,102   | 12.1 K ohms   | RM057          |
| R3,103   | 316 ohms  | RM015          |
| R4,104   | 28.0 K ohms   | RM053          |
| R5,105   | 3.92 K ohms   | RM054          |
| R6,106   | 12.1 K ohms   | RM057          |
| R7,107   | 1.10 K ohms   | RM025          |
| R8-R11   | 1 megohm  | RM044          |
| R108-    |   |                |
| R111     | 1 megohm  | RM044          |
| R12,112  | 150 ohms  | RM013          |
| R13,113  | Potentiometer, VOLUME,<br>2 X 50K audio taper           | RP025          |
| R14,114  | 274 K ohms  | RM055          |
| R15,115  | 10.0 K ohms   | RM023          |
| R16,116  | 1.10 K ohms   | RM025          |
| R17,117  | Potentiometer, BALANCE,<br>2 X 50K linear taper         | RP024          |
| R18,118  | 22.1 K ohms   | RM035          |
| R19,119  | 4.75 K ohms   | RM052          |
| R20,120  | 1.10 K ohms   | RM025          |
| R21,121  | 1.10 K ohms   | RM025          |
| R22,122  | 4.75 K ohms   | RM052          |
| R23,123  | Potentiometer, TREBLE,<br>2 X 25K, special taper        | RP023          |
| R24,124  | Potentiometer, BASS,<br>2 X 25K, special taper          | RP023          |
| R25,125  | 22.1 K ohms   | RM035          |
| R26,126  | 150 ohms  | RM013          |
| R27,127  | 1000 ohms, carbon film, 5%                              | RC015          |
| R28,29   | 470 K ohms, carbon film, 5%                             | RC044          |
| R30      | 10 K ohms, carbon film, 5%                              | RC016          |
| R31      | 39 K ohms, carbon film, 5%                              | RC038          |
| R32      | 2.2 megohms, carbon film, 5%                            | RC028          |
| R33      | 270 ohms, carbon film, 5%                               | RC029          |
| R34,35   | 100 K ohms, carbon film, 5%                             | RC017          |
| R36      | 4.7 K ohms, carbon film, 5%                             | RC042          |
| R37      | 1.8 K ohms, carbon film, 5%                             | RC023          |
| R38      | 390 K ohms, carbon film, 5%                             | RC057          |
| R39      | 2.7 K ohms, carbon film, 1/2 Watt, 5%                   | RD124          |
| S1-S4    | Switch, Selector assembly, Non-shorting                 | SA117          |
| S5       | Switch, POWER, Push-push type. SPST                     | SL113          |
| T1       | Transformer, 120VAC Primary<br>alternate 220VAC Primary | TA126<br>TA127 |

## H100 COMPONENT LIST

| Part No. | Description                                | Part No. | Description | Part No.                                 |
|----------|--|----------|-------------|--|
| .101     | Capacitor, polycarbonate. 1.0 MFD/100V     | CC126    | C22,23      | Capacitor, polypropylene. 0.033 MFD/160V |
| .102     | Capacitor, polypropylene. 120 pFD/160V     | CP112    | C24,25      | Capacitor, polypropylene. 0.033 MFD/160V |
| .103     | Capacitor, polypropylene. 0.027 MFD/160V   | CP141    | C26,27      | Capacitor, electrolytic. 470 MFD/25V     |
| .104     | Capacitor, polypropylene. 0.08 MFD/160V    | CP142    | C28,29      | Capacitor, polypropylene. 0.033 MFD/160V |
| .105     | Capacitor, electrolytic, NP. 220 MFD/10V   | CN112    | C30         | Capacitor, ceramic disk. 0.005 MFD/1000V |
| .106     | Capacitor, polypropylene. 0.033 MFD/160V   | CP138    | C31,32      | Capacitor, electrolytic, NP. 4.7 MFD/25V |
| .107     | Capacitor, polypropylene. 2.2 MFD/100V     | CP115    | C33         | Capacitor, polypropylene. 0.033 MFD/160V |
| .108     | Capacitor, polycarbonate. 1.0 MFD/100V     | CC126    | C34         | Capacitor, ceramic disk. 0.005 MFD/1000V |
| .109     | Capacitor, electrolytic, NP. 220 MFD/10V   | CN112    | C35,135     | Capacitor, polypropylene. 47 pFD         |
| .110     | Capacitor, polypropylene. 0.033 MFD/160V   | CP138    | D1-D5       | Diode, 1N4003                            |
| .111     | Capacitor, polycarbonate. 1.0 MFD/100V     | CC126    | D6          | LED, red, nipple tip                     |
| .2,112   | Capacitor, polypropylene. 0.1 MFD/1%/160V  | CP143    | F1          | Fuse, 1/16 A. (slo-blo)                  |
| .3,113   | Capacitor, polypropylene. 0.1 MFD/1%/160V  | CP143    | IC1-IC4     | Operational Amplifier, MC33078/5532      |
| .4,114   | Capacitor, polypropylene. 0.01 MFD/1%/160V | CP139    | IC5         | Dual Comparator, LM393                   |
| .5,115   | Capacitor, polypropylene. 2.2 MFD/100V     | CP115    | IC6         | Regulator, negative, 7915                |
| .3,17    | Capacitor, electrolytic. 1000 MFD/50V      | CL124    | IC7         | Regulator, positive, 7815                |
| .3,19    | Capacitor, electrolytic. 470 MFD/25V       | CL111    |             |  |
| .3,21    | Capacitor, polypropylene. 0.033 MFD/160V   | CP138    |             |  |

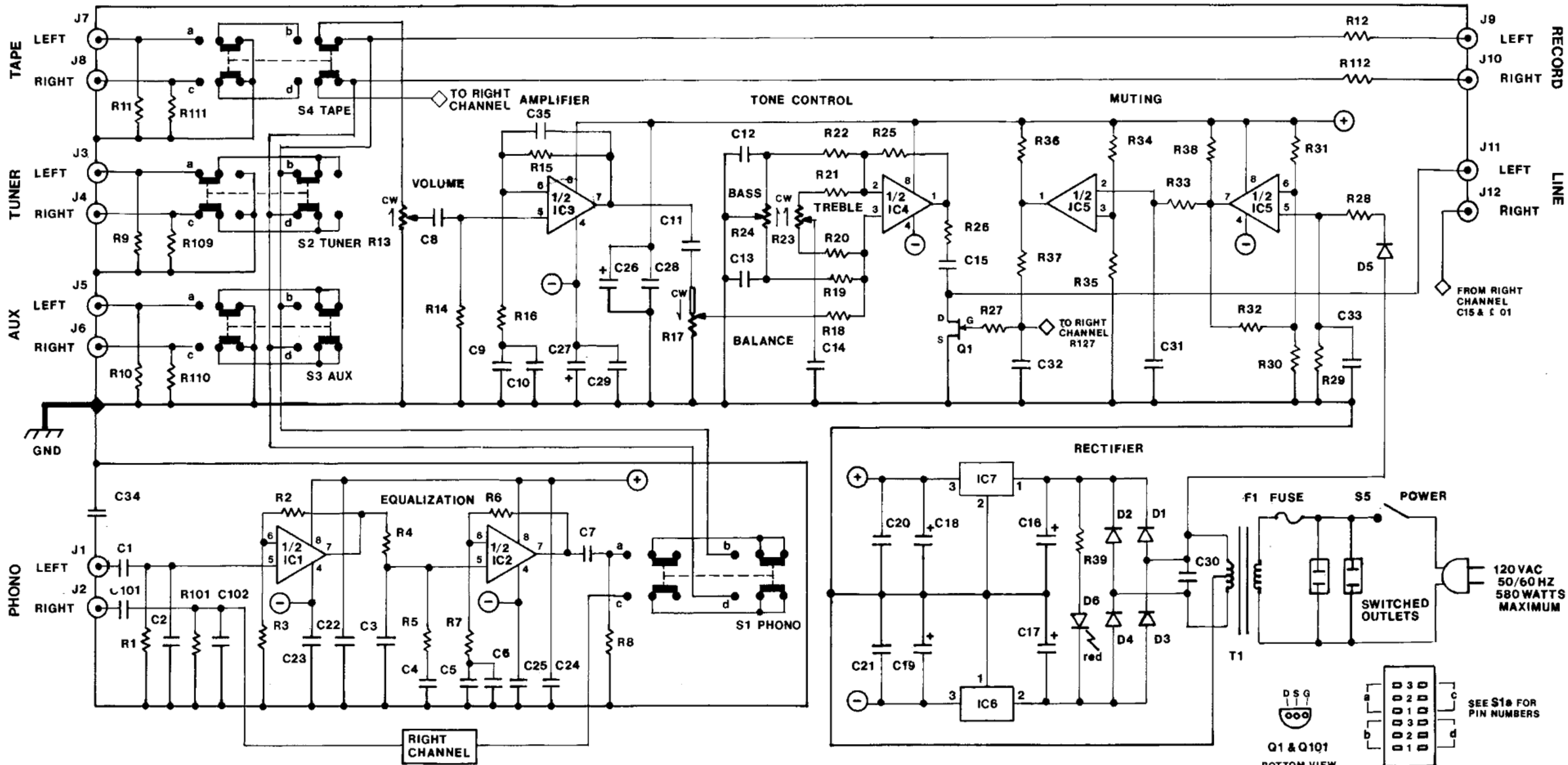

**NOTES:**

- 1 - Left channel shown. Right channel part numbers add 100.
- 2 - S2 shown depressed / TUNER selected.

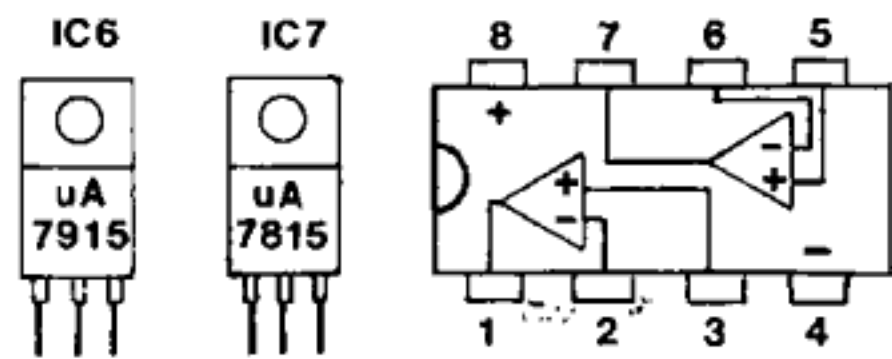

**PREAMPLIFIER DH100**  
**SCHEMATIC DIAGRAM PC23B**  
**SERIES 2**

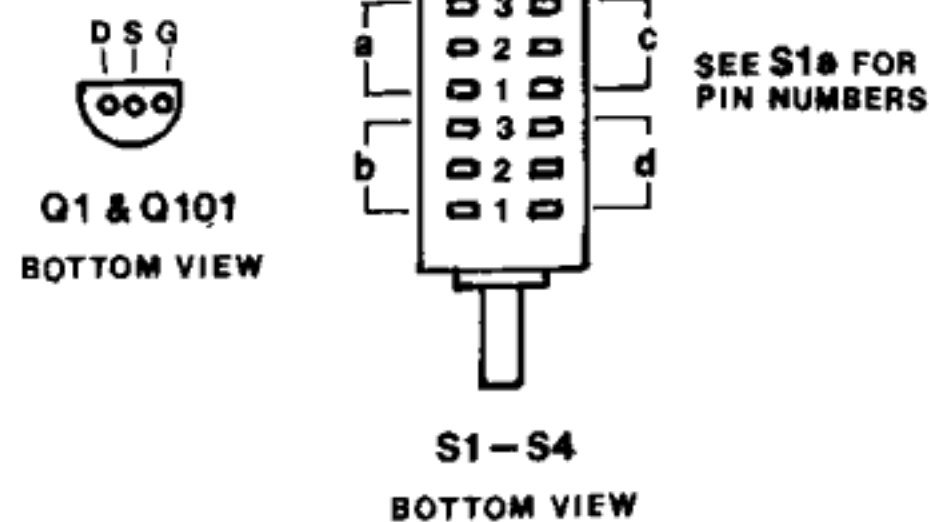

120VAC  
50/60 HZ  
580 WATTS  
MAXIMUM