

TS-50S SYSTEM APPLICATIONS

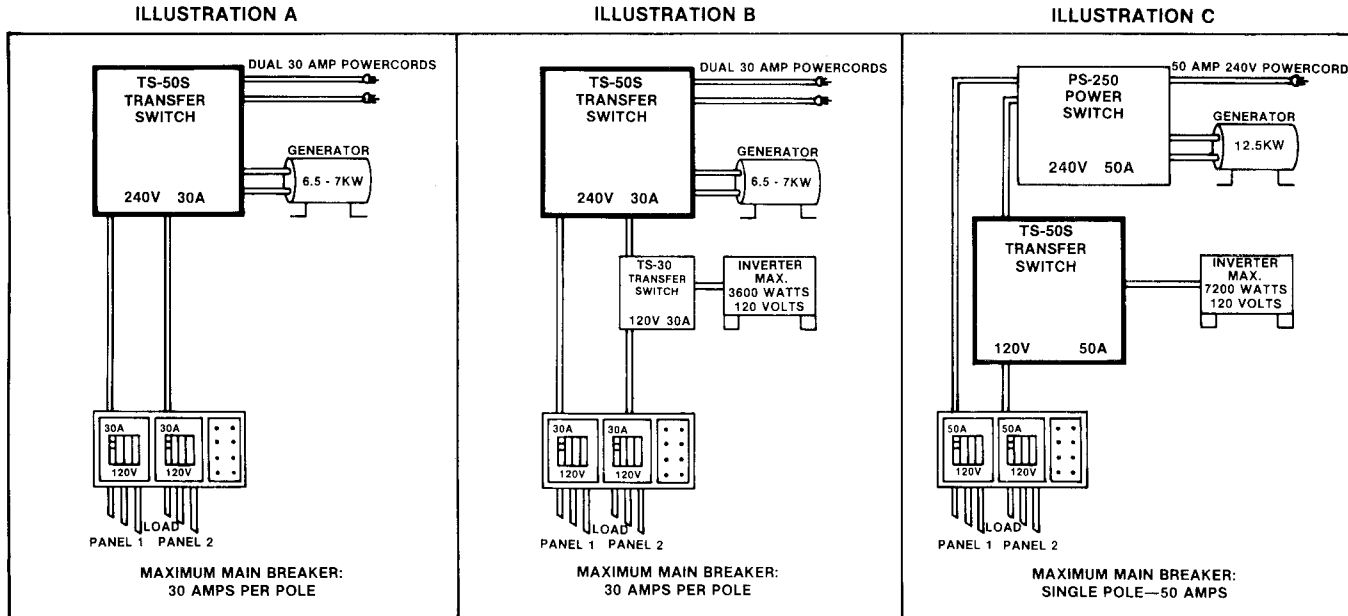

INSTALLATION INSTRUCTIONS

DIAGRAM ONE

EXAMPLE: Attach hot lead from powercord #1 to terminal on HOT RELAY marked powercord #1 (top left terminal). Attach neutral lead from powercord #1 to same terminal on Neutral RELAY (top left terminal), again marked powercord #1. Attach all grounds together in ground lug provided. Continue in similar manner with all connections.

DIAGRAM TWO

In this diagram, as both left and right poles of the relays are

wired in parallel in order to carry the 50 amp load, wires are tied to BOTH left and right terminals on each relay.

EXAMPLE: From inverter leads, connect white neutral wire to both of the top terminals of NEUTRAL RELAY. Connect black hot wire to both top terminals of HOT RELAY. Suggested method would be a short jumper wire cut from each incoming lead. Use crimp-type ring terminals on all wire ends where they attach to relay screw posts, and use stranded wire.

DIAGRAM ONE

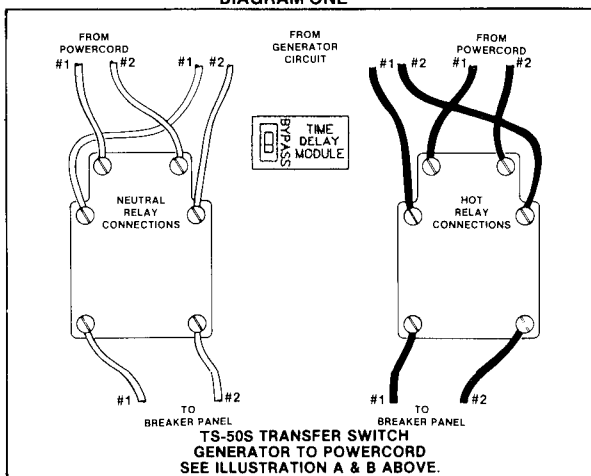
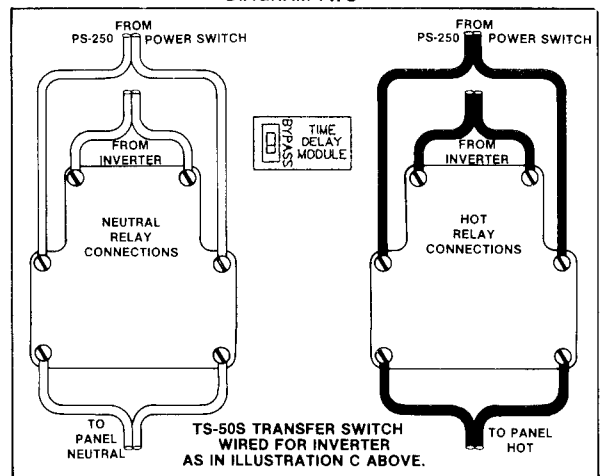

DIAGRAM TWO



Note: ALL NEUTRAL CONNECTIONS go to left relay, illustrated by white wires. ALL HOT CONNECTIONS go to right relay, illustrated by black wires.

SPECIFICATIONS

RELAYS—DPDT, break before make, 30 amps per pole.
 COIL—110 volt DC, 2 watt current.
 TIME DELAY—generator circuit only, timer range 20-55 seconds relative to ambient temperature, complimentary to generator engine warm-up requirements.
 PHYSICAL SIZE—8" L x 8" W x 4" H.
 WEIGHT—6 pounds.

TIME DELAY BYPASS

- Locate, at one end of the board, a tiny jumper (it looks like a miniature electrical plug with no cord fastened to it) mounted on a row of three pins. The jumper connects two of the three pins, the middle pin and one end pin.
- To change the operation from delayed to instant, or visa versa, with a pair of needlenose pliers carefully remove the jumper from the two pins, and mount it on the middle pin and THE OTHER END PIN. Voila! All done.

LIMITED WARRANTY SUMMARY

All Todd Engineering products are designed and manufactured in the U.S.A. They are covered by a limited warranty against manufacturing defects for a two year period from date of purchase. Our responsibility if warranty service is needed is limited to the repair or replacement of the failed part, and return postage to the customer. There are other limitations to the warranty; please refer to the separate Todd Engineering Limited Warranty as printed in its entirety.