



GIRARD PRODUCTS, LLC.

Owner's Manual

Model: GSWH-1

**Demand Tankless Water Heater
Power Blower Induced Draft
Dual BTU
LP Gas**



- **Installation**
- **Operation**
- **Service and Maintenance**

Installation and service must be performed by a recommended installer, service agency or gas supplier.

This water heater is certified for installation in Recreation Vehicles (RV's) and is not for use in Marine or Space Heating Applications.

CAUTION:

Read and Follow all the Safety Rules and Instructions before operating this Appliance.



CSA Approved

Girard Products LLC, 1361 Calle Avanzado, San Clemente CA 92673 U.S.A
Owner's Manual Part No. 1GWH9401, REV. 4

Patent Pending

TANKLESS WATER HEATER - Model GSWH-1

Installer/Customer Responsibilities

- Installation and Service must be performed by a Girard Products LLC recommended installer, service agency or gas supplier.
- Do not attempt installation as a Do-it-Yourself project
- Read and observe all safety rules
- Shut off gas appliances and pilot lights when refueling.
- Keep these instructions and warranty for future reference
- Follow all applicable State and Local Codes
- Follow a regular schedule of maintenance as outlined in this manual



This is the safety alert symbol. It is used to alert you to potential personal injury hazards. Obey all safety messages that follow this symbol to avoid possible injury or death. Failure to follow these alerts could result in Fire, Explosion or even Death.



WARNING – FIRE OR EXPLOSION

WARNING: These instructions must be followed exactly, or a fire or explosion may result causing property damage, personal injury or death.

- Do not store or use gasoline or other flammable vapors and liquids in the vicinity of this or any other appliance.
- **FOR YOUR SAFETY --- WHAT TO DO IF YOU SMELL GAS**
 - DO NOT attempt to light any appliance.
 - DO NOT touch any electrical switch, or use any phone or radio in the vehicle.
 - DO NOT start the vehicle's engine or electric generator.
 - Evacuate all persons from the vehicle.
 - Shut off the gas supply at the gas container or source.
 - Contact the nearest certified service technician or gas supplier for repairs.
 - If you cannot reach a certified service technician or gas supplier, contact the nearest fire department.
 - DO NOT turn on the gas supply until the gas leak(s) has been repaired.
- Installation and Service must be performed by a Girard Products LLC recommended installer, service agency or gas supplier.



CRITICAL INSTALLATION WARNINGS

- Installation and Service must be performed by a Girard Products LLC recommended installer, service agency or gas supplier.
- This product is not designed for Do-it-Yourself Installation.
- Install **ONLY** in recreation vehicles (RV's). RV's are recreation vehicles designed as temporary living quarters for recreation, camping, or travel use having their own power or towed by another vehicle. This water heater is **NOT** designed for Marine or Space Heating applications
- All combustion air must be supplied from the outside of the RV, and all products of combustion must be vented to the outside of the RV.
- **DO NOT** vent water heater with a venting system serving another appliance or to an outside enclosed porch area.
- **DO NOT** modify water heater in any way. This is dangerous and will void the warranty.
- **DO NOT** alter water heater for a positive grounding system.
- **DO NOT** HI-POT water heater unless the electronic ignition control (circuit board) has been turned 'OFF' (Power switch is in "Off" position)
- **DO NOT** use battery charger to supply power to water heater even when testing.
- Protect building materials from flue gas exhaust.
- Install the water heater on an exterior wall, with access door opening to the outdoors.
- **DO NOT** lift the water heater or carry it by holding the blower assembly support bracket/exhaust tube.
- **DO NOT** modify the length of the wires protruding past the strain relief from the rear of the housing.

USA AND CANADA - FOLLOW ALL APPLICABLE STATE AND LOCAL CODES

IN THE ABSENCE OF LOCAL CODES OR REGULATIONS REFER TO CURRENT STANDARDS OF:

- Recreational Vehicles ANSI A119.2/NFPA 501C.
- CSA standard Z240 RV Series, Recreational Vehicle.
- Park Trailers A119.5
- National Fuel Gas Code ANSI Z223.1 and/or CAN/CGA B149 Installation Codes
- Federal Mobile Home Construction & Safety Standard, Title 24 CFR, part 3280, or when this Standard is not applicable, the Standard for Manufactured Home Installations (Manufactured Home Sites, Communities and Set-Ups), ANSI A255.1 and/or CAN/CSA-Z240 MH Series, Mobile Homes.
- National Electrical Code ANSI/NFPA No. 70 and/or CSA C22.1

INSTALLATION



WARNING! CAUTION!

- Improper installation, adjustment, alteration, service or maintenance can cause property damage, personal injury or loss of life.
- Installation and Service must be performed by a Girard Products LLC recommended installer, service agency or gas supplier.
- This product is not designed for do-it-yourself installation.
- DO NOT lift the water heater or carry it by holding the blower assembly support bracket/exhaust tube (Figure 1).

The following instructions apply to the most common type of installation for Girard Products GSWH-1 water heater. Consult with Girard Products, LLC technical support or engineering department if you have any additional questions regarding your specific installation/application.



IMPORTANT!

- For proper operation this water heater requires a minimum water flow of 1.0 Gallon per Minute (gpm) for each Hot Water faucet it supplies.

Select a suitable location

The water heater is designed to be installed on a floor or a fixed platform with access to water, gas and electrical connections from the back. It is recommended that the GSWH-1 be located as near the center of the coach as possible.

DO NOT INSTALL IN AN AREA WHERE ONE OR BOTH THE INLET AIR VENT AND FLUE VENT CAN BE COVERED WHEN A DOOR OR ACCESS PANEL OF THE VEHICLE IS OPENED.

DO NOT INSTALL WHERE THE FLUE VENT IS CLOSER THAN ONE FOOT IN ALL DIRECTIONS FROM ANY WINDOW OR OPENING INTO THE VEHICLE.

DO NOT INSTALL THE WATER HEATER OR ANY OTHER APPLIANCE WHERE IT CAN VENT INTO AN AREA COVERED BY AN AWNING, CANOPY OR ANY OTHER ENCLOSURE.

(Note: The water heater can be installed under an RV roll-out/retractable type awning providing the awning does not have an enclosure such as a screen room and/or some type of "walled enclosure")

Site Preparation

To install on carpeted area you must install a metal or wood panel under the water heater that extends at least 3 inches beyond the width and depth of the unit. If water leakage can result in damage to the adjacent area, install a drain pan that can be drained to outside of the vehicle, under the water heater.

Verify that a clearance of 1 inch will remain after installation between the top surface of the water heater and any combustible material. 0 inch clearance is acceptable for the sides.

Make sure that the front edge of the opening is surrounded by a solid frame to firmly anchor the water heater; if needed, build an appropriate frame using 2"X2" elements (Figure 1)

The rough opening for the GSWH-1 should be 12.75" X 12.75" with right angle corners. The exterior wall opening must be the same dimensions with no radius corners.

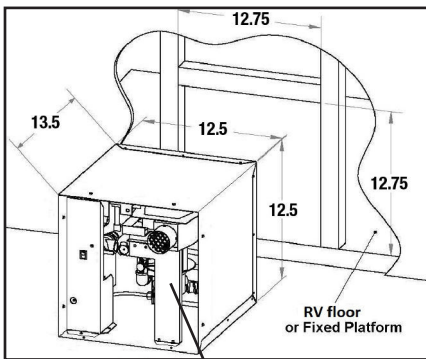

Figure 1 *Blower Assembly Support Bracket/Exhaust Tube*

Ensure that water and gas connections from the vehicle are in place for installing the unit. Allow sufficient length and flexibility in the water and gas lines to reach the connections while the unit is partially inserted into the opening.

Water Heater Installation

Remove the water heater from the box by grasping the metal sides of the housing and lifting upward until it is free of the box.



IMPORTANT!

- Lifting or moving the water heater using the Blower Assembly Support Bracket/Exhaust Tube (Figure 1) may result in improper alignment of the vent and/or improper alignment of the Sail Switch.

Partially insert the water heater into the opening and connect both Hot and Cold water lines to the appropriate 1/2"NPT fittings. Connections can be made using PEX swivel nut adaptors with NPS straight threads and a cone seal or with a standard 1/2"FPT nut. The PEX swivel nuts require only hand tightening. When using a standard 1/2"FPT nut use Teflon tape and/or PTFE pipe paste and do not over-tighten (Figure 2, page 6).



PRODUCT DAMAGE!

- **Excessive torque will damage the Cold Water and Hot Water Inlets. DO NOT over tighten.**

Connect the gas using a 3/8" LP Gas line. Place the grommet on the line ahead of the compression nut before flaring the tube (Figure 2). Use additional caulking as needed to complete a permanent seal with the housing around the rubber grommet.

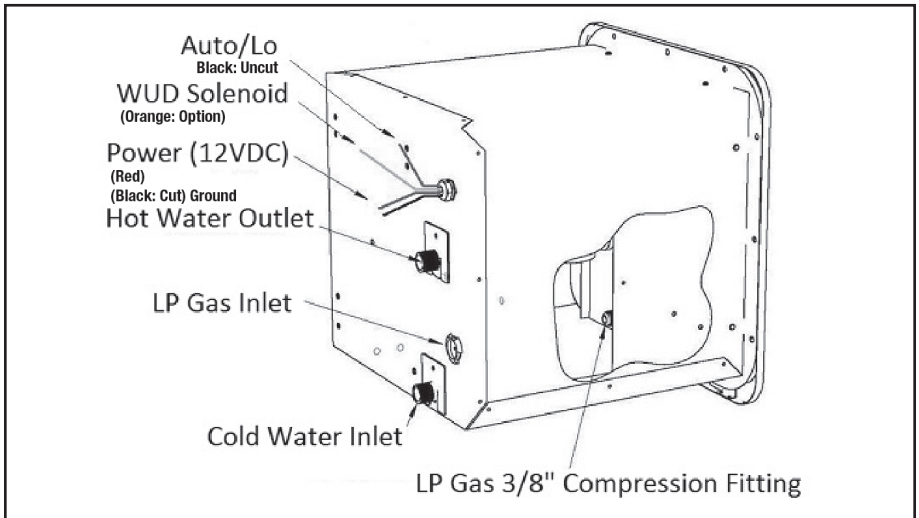

Figure 2



IMPORTANT! CRITICAL INSTALLATION

- DO NOT cut any wires.
- The length of the external wires, those wires extending beyond the strain relief from the rear of the housing (Figure 2), must NOT be shortened for any reason. Shortening these wires will prevent the removal of the Control Housing during servicing and/or testing.



NOTICE

- If you wish to install the flange as an integral part of the water heater housing proceed to B: Installation of water heater with Integral Flange (below).

A: Installation of water heater with separate flange

1. Complete the “skin” application to the vehicle’s outer wall.
2. Position water heater housing into the frame opening with the front edge aligned evenly to the exterior wall (See Figure 3).
3. To prevent water and air leaks apply sufficient caulking around the entire frame opening and the exterior edge of the water heater housing. Use a suitable caulking material that will result in a permanent seal between the water heater and the vehicle’s frame.
4. Press the side walls of the water heater housing firmly against the frame to expel any bubbles and ensure a good bond.
5. When ready to proceed, apply additional caulking or butyl tape to the back of the door flange that will contact the RV sidewall around perimeter of the opening.
6. Insert the door flange into the water heater housing and press the flange firmly against the sidewall.
7. Secure the flange to the vehicle using No.8 – $\frac{3}{4}$ ” flat head screws through each hole along the perimeter. Verify that a tight seal exists between the side wall and the flange. If not, repeat above steps.
8. Align each hole along the inside frame of the flange with the corresponding holes in the water heater housing and secure to the frame using No.8 – $\frac{3}{4}$ ” flat head screws using two screws per side.
9. Remove any excess caulking and clean all surfaces.

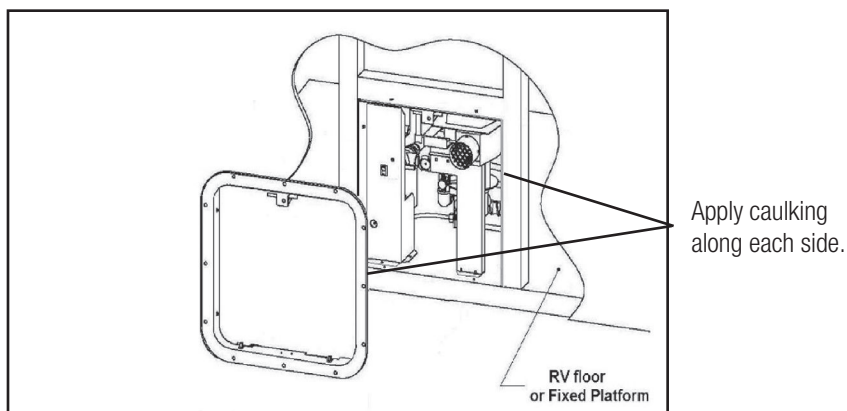

Figure 3

B: Installation of water heater with integral flange

1. Protect the side wall with masking tape or other suitable means to insure that it is not damaged while installing the water heater.
2. Position the water heater so that the front edge extends from the opening approximately 2" and insert the door flange into the housing.
3. Permanently attach the flange to the housing using stainless steel screws or stainless steel rivets with recommended grip range of .188" to .129" and hole size of .129" to .133".
4. To prevent water leaks apply a good amount of caulking or butyl tape on the sidewall around perimeter of the opening that will be covered by the flange and along the front edge of the housing that will contact the mounting frame.
5. Slide the water heater in place into the opening and press the door flange against the sidewall.
6. Secure water heater housing unit to the vehicle using No.8 – 3/4" flat head screws through each hole in the door flange (Figure 4). Verify that a tight seal exists between the side wall and the flange. If not, repeat above steps.

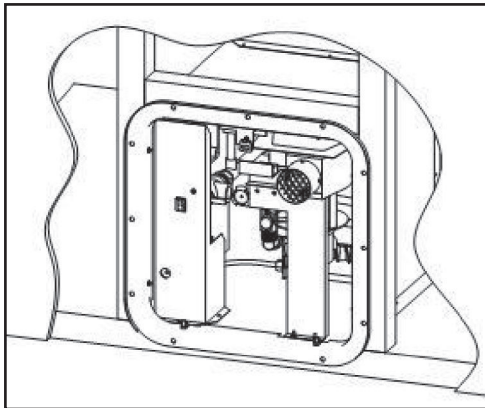

Figure 4

C: Installation of mode switch

1. SET THE POWER SWITCH TO THE "OFF" POSITION and connect the power wires to a 12VDC circuit from the DC panel protected with a 10 amp fuse. The Red wire is positive (+) and the Black wire is negative (-) and is internally connected to ground.
2. To install the remote Mode Switch (Figure 5), connect one pole of the switch to the Auto/Low wire and the other pole to ground.

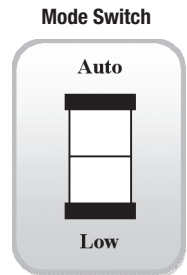

Figure 5

D: Functional tests



WARNING – FIRE AND/OR EXPLOSION

WARNING: These instructions must be followed exactly, or a fire or explosion may result causing property damage, personal injury or death.

DO NOT use matches, candles or other sources of ignition when checking for gas leaks.

1. Verify the power switch is in the “OFF” position
2. Turn on the water supply to the unit.
3. Open and then close the hot AND cold water faucets in the vehicle to fill the pipes with water. Close the faucets when the water is flowing smoothly and verify that there are no leaks at the connections and within the water heater.
4. Turn on the gas supply and check all gas connections for gas leaks with leak detection solution.
5. Turn the power switch to the “ON” position.
6. Open a hot water faucet and verify that the unit lights and supplies warm water at the faucet.
7. **WHILE THE UNIT IS RUNNING**, verify that there are no leaks at the gas connections to the control valve and to the burner.

E: Door Installation

After mounting and securing the unit in the chosen location, install the door making sure that:

1. The door mounting posts on the door flange are properly aligned with corresponding holes along the door's lower edge. If needed, carefully re-align the posts with pliers.
2. The exhaust tube extends beyond the door's face through the clearance hole BUT not beyond the face of the door. Be sure that the exhaust tube is seated properly. See Figure 6



WARNING! PRODUCT DAMAGE

- DO NOT FORCE THE DOOR CLOSED with the tube pressed inside the door. Doing so may damage the door or the exhaust tube and misalign the sail switch.

3. Ensure that the door lock operates smoothly and engages easily.

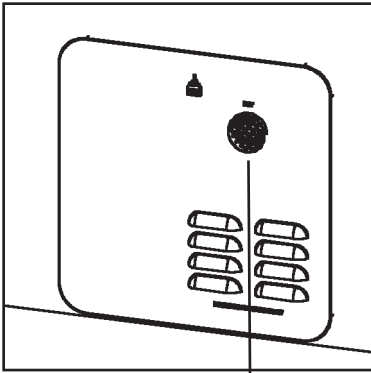

Figure 6 *Insert exhaust tube through door opening*



WARNING! CAUTION!

- Disconnect the unit from the gas supply line during any pressure testing of the gas system in excess of $\frac{1}{2}$ PSIG (3.4 kPa, 14" water column [W.C.]). DO NOT set inlet pressure higher than the maximum indicated on rating plate of gas valve (13" W.C.).
- If an external electrical source is utilized, the appliance, when installed, must be electrically grounded in accordance with local codes or, in the absence of local codes, with the National Electrical Code, ANSI/NFPA 70 and/or the CSA C22.1, Canadian Electrical Code.

This completes the installation of the Model GSWH-1 water heater.

OPERATING INSTRUCTIONS



CONSUMER SAFETY WARNING

- Use with LP gas only.
- Shut off gas appliances and pilot lights when refueling.
- Turn gas OFF at the LP tank when vehicle is in motion. This disables all gas appliances and pilot lights. Gas appliances must never be operated while vehicle is in motion.
- LP tanks must be filled by a qualified gas supplier only.
- Should overheating occur, turn gas OFF at the LP tank and turn the operating switch to the OFF position.
- **DO NOT TURN ON THE COLD WATER FAUCET TO ADJUST THE TEMPERATURE.**

Understanding How the Girard Tankless Water System Works

The Girard Products model **GSWH-1** is a new 'induced-draft', tankless water heater designed specifically for Recreation Vehicles (RV). Its configuration and size are consistent with the tank based RV water heaters currently in use and is designed for OEM's and after market use by the RV industry. A main feature of the GSWH-1 is a Dual BTU burner that automatically adjusts the level of the flame (High or Low) depending on the temperature of the inlet water.

A tankless water heater heats water while it is being used i.e., on demand. The output temperature of the water depends on the temperature of the inlet water AND the amount of hot water that is drawn. If the inlet water temperature is over 65°F the model **GSWH-1** will generate water in the range of 105°F to 120°F (on Low flame) depending on the water flow selected by the user.

To operate, **first set the Power Switch to the ON** position and set the Mode Switch to **AUTO**, then **FULLY** open the **HOT** Water Faucet by turning the faucet knob counter clockwise; the water will begin to heat up once the water in the piping has been purged. **DO NOT TURN ON THE COLD WATER**. Then **DECREASE** the flow of the water (turn the faucet knob clockwise) until you achieve the desired temperature. The hot water valve behaves very much like a typical mixing valve: it **INCREASES** the temperature when the water flow is **REDUCED**. To **DECREASE THE WATER TEMPERATURE** (i.e., make the water cooler), increase the flow of the water by turning the faucet knob counter clockwise thereby increasing the flow. **DO NOT USE COLD WATER TO ADJUST THE TEMPERATURE.**



IMPORTANT!

- **The presence of a flow restrictor in the hot water line may limit your ability to reach a comfortable water temperature. For best results remove the restrictor in the shower head.**

In a conventional installation the Girard Tankless Water Heater is connected to:

1. The RV's cold water system deriving its water input from a pressurized (45 psi or greater) source such as a shore connection or an RV water pump connected to the fresh water storage tank.
2. The RV's Hot water system (i.e. faucets and shower)
3. The RV's LP Gas system capable of supplying its rated BTU requirement.
4. The RV's 12VDC filtered electrical power distribution panel utilizing a 12 Volt, 10 amp fused line.

Operation

Open the door of the Girard Products model GSWH-1 to acquaint yourself with the unit and its controls. The small user panel located on the left side of the unit (see Figure 7) includes:

1. LED Indicator
2. Power ON/OFF switch

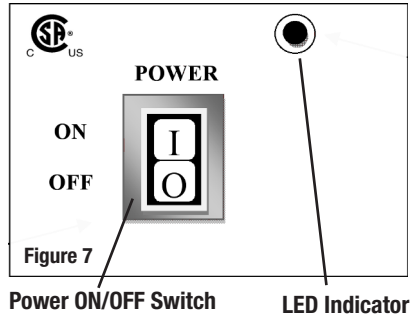

To begin operation simply set the switch to the **'ON'** position (Figure 7), set the Mode switch (Figure 5) to the Auto position, **AND** open the **HOT WATER** faucet you want to use. The unit will automatically light and start heating your water. **DO NOT** use cold water to adjust the temperature.

By manually setting the MODE switch to automatic, the model GSWH-1 automatically senses and adjusts the flame level (High or Low) depending on the temperature of the inlet cold water (the water coming into the GSWH-1). The flame will change from High to Low if the temperature of the inlet water goes above 70°F and will switch back to High when the inlet water goes below 65°F. Manually switching the Mode switch from **AUTO** to **LOW** overrides the automatic function and forces the flame to stay in **LOW** even if the inlet water is less than 65°F. This can be desirable when the cold water inlet temperature is very cold and the inlet water pressure is below 1.0 gpm which could result in limiting (see Notice below). The system will remain in Low until manually switched to Auto.



NOTICE

You will notice that if you increase the flow of hot water (i.e., open the faucet more) the temperature will automatically **DECREASE** since more water is being heated.

If, on the other hand, you decrease the water flow (close the faucet) the temperature will **INCREASE. DO NOT TURN ON THE COLD WATER.** If you reduce the water flow too much, which will result in **HOTTER** water, the rising temperature will increase and trigger the Safety Cut Off or 'limit switch' (125°F) and the burner will shut off. This is commonly referred to as "limiting" and is a safety feature designed to protect against accidental scalding. Whenever the temperature rises to a comfortable level, **INCREASE** the water flow (open the faucet) to maintain the desired temperature and prevent the burner from shutting off (limiting).

If a shut off does occur, you will notice a decrease in the water temperature. In this case **do not close the faucet**, but rather open it more and the water heater will relight after a few seconds; you may then re-adjust the temperature by reducing the flow appropriately (i.e., less than the previous setting to avoid repeated limiting).

WINTERIZATION

Freezing of the water heater and its plumbing components will result in severe damage not covered by warranty. For this reason it is advisable to follow the recommendation(s) below if the unit is to be stored in a freezing environment or for long periods of time. At the start of the winter season or before traveling to a location where freezing conditions are likely, the unit must be winterized. The very small amount of water present in the heat exchanger **DOES NOT** require the installation of a bypass kit. Winterization can be accomplished using one of the two common methods of winterization used for RV water systems:

- **Compressed Air method:** Drain all water from the system opening one tap at a time and using compressed air to purge all remaining water.
- **Anti-freeze method:** Follow the recommendations of the Recreational Vehicle manufacturer and fill the system with a non toxic anti-freeze. Make sure that the anti-freeze flows from each tap to complete the process.

PRESSURE - TEMPERATURE RELIEF VALVE

This water heater is equipped with a temperature and pressure relief valve that complies with the standard for Relief Valves and Automatic Gas Shutoff Devices for Hot Water Systems, ANSI Z21.22.



WARNING – SCALDING INJURY-EXPLOSION

- Valve is not serviceable; if defective it must be replaced.
- Tampering with valve will result in scalding injury. Do not place a plug or reducing coupling on outlet part of valve. If you use a discharge line allow complete drainage for both valve and line.
- Tampering with valve will void the warranty.

THIS VALVE IS A SAFETY COMPONENT AND MUST NOT BE REMOVED FOR ANY REASON OTHER THAN REPLACEMENT.

WHEN REPLACING THE PRESSURE – TEMPERATURE RELIEF VALVE

- **DO NOT** install anything less than a combination pressure–temperature relief valve certified by a nationally recognized testing laboratory that conducts periodic inspections of such products and certifies them as meeting the requirements for Relief Valves and Automatic Gas Shutoff Devices for Hot Water Supply Systems, ANSI Z21.22. Valve must have a maximum set pressure not to exceed 150 psi.
- Install valve into opening provided and marked for this purpose on water heater.
- Installation must conform with local codes or in the absence of local codes, American National Standard for Recreational Vehicles, ANSI A119.2/NFPA 501C.

Functional Description

We include here additional information needed to identify the various components of the system in order to facilitate communications of the user with Girard Products or an authorized Service Center for any questions regarding the proper operation of the water heater. The model GSWH-1 consists of the following main sub-systems and components:

1. Water Sub-System:

- 1.1. Flow Switch
- 1.2. Heat Exchanger
- 1.3. Limit Switch / Emergency Cut Off (ECO): (Normally closed; open $T > 122^{\circ}\text{F}$)
- 1.4. P/T Valve: to provide pressure relief in case of overheating

2. Gas Sub-System

- 2.1. Regulator with Dual Solenoid Valve
- 2.2. Dual BTU (Hi/Lo) valve (Powered=Maximum output / Unpowered=Reduced output)
- 2.3. Burner (Blade type; high efficiency)
- 2.4. Auto/Low thermostat: (normally closed; opens at 70°F)

3. Flue Sub-System

- 3.1. Flue Collector
- 3.2. Exhaust Blower
- 3.3. Flue outlet

4. Electrical Sub-System

- 4.1. 12VDC connection wires
- 4.2. Power switch
- 4.3. Blower Motor
- 4.4. Microprocessor based Circuit Board (Spark Igniter, Safety and Diagnostics)
- 4.5. Spark Igniter
- 4.6. Sail switch to detect air flow at the exhaust.
- 4.7. Mode Selector (Auto/Lo) to control the operation of the Dual BTU valve

In the following pages we present:

- 1. Figure 9:** Shows an exploded view of the GSWH-1 water heater with identification labels for all components.
- 2. Figure 10:** A wiring diagram with all electrical components showing all interconnections and the wire colors adopted.
- 3. Figure 11:** A Circuit Ladder Diagram to illustrate the Control logic and functionality of each electrical component

MAINTENANCE

Routine Maintenance

We recommend that the GSWH-1 water heater be inspected monthly by the user and at least once a year by a Girard Products LLC recommended service technician.

Before an inspection, make sure that the LP Gas and Water systems are turned on.

A routine inspection must include the following items:

1. Inspect the integrity of the sealing (caulking or tape) between the side wall and the door of the water heater and ensure that the unit is solidly mounted to the vehicle.
2. Verify that the air inlet openings (louvers) are completely open and clear of any debris including mud, leaves, twigs, insects etc. Remove all obstructions to allow full air flow.
3. Insects, including mud wasps and spiders, can build nests in the Exhaust Tube Outlet and Exhaust Collector which will affect the performance of the unit. Inspect the Flue Outlet Tube and Exhaust Collector to make sure that they are unobstructed and that the screen is clean. If debris or insects are present, clean and vacuum to remove any remaining debris. The use of any type of aftermarket screen to cover the vent is not permitted and will void the warranty.
4. Open the cover and verify that no debris or extraneous combustible materials are present anywhere (especially in the area of the burner and the gas controls); remove any item present and wipe clean the bottom of the housing.
5. Inspect the interior surface of the housing for any cracks or corroded areas that could allow penetration of gases into or out of the interior of the vehicle. Check especially around the Hot Water, Cold Water, Gas and electrical connections.
6. Check that all wire connections are firmly in place and there are no signs of chafing or cracks on the insulation. Verify that the spark ignition cable between the Control Board and the igniter is securely in place and not shorted to any metal component.
7. At least once a year activate the Relief Valve by lifting the lever on top of the valve. **MAKE SURE THAT THE WATER HEATER HAS NOT BEEN ON RECENTLY AND THE WATER FLOWING FROM THE HOT WATER OUTLET IS COLD.**
8. Turn on the power to the water heater and open a hot water faucet to inspect the flame of the burner. The flame should be of the normal bluish appearance that indicates proper combustion. This can be accomplished by observing the flames through the sight hole and looking at the burner under the edge of the heat exchanger (See Figure 8).

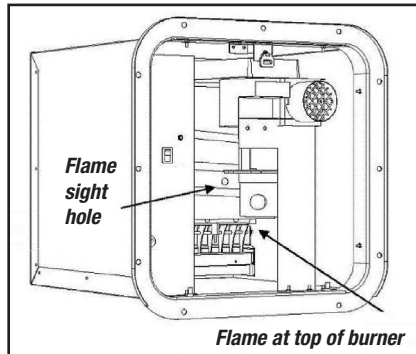

Figure 8

Troubleshooting

Whenever the user opens a hot water faucet, the water activates the “Flow Switch”, which provides a thermostatic request to the Circuit Board for Ignition. Upon the request the Circuit Board performs the following tasks:

1. Microprocessor reset and self-check
2. Verification that no flame is present
3. Verification that the Sail Switch is open
4. Turn on the Blower
5. Upon detection of combustion air flow, starts the ignition routine by opening the gas valve and supplying the first sparking sequence.

Normally the ignition trial is successful and the user will start receiving warm water at the faucet.

The Control Board detects the conditions that could result in a hazardous situation and either prevents the Gas ignition to occur or immediately shuts down the flame by interrupting the gas flow to the burner. The failures detected by the Control Board are:

Failure to light

If the burner fails to light, or if flame is not detected during the first ignition attempt, the gas valve is deenergized and the control goes through an inter-purge delay before ignition is attempted again. The control will attempt two additional ignition sequences before going into '**LOCKOUT**' after which the valve relay will remain de-energized and the blower will turn off after a five minute delay. (Lockout Condition)

Recovery from 'lockout' requires a manual reset by either resetting the thermostatic demand (turning off the water flow) or turning off the power for a period of 5 seconds and then opening the **HOT Water Faucet**.

Flame failure

If the established flame signal is lost while the burner is operating, the control will respond within 0.8 seconds, the gas valve is de-energized and a new inter-purge and ignition routine will begin. If the burner does not light, the control will de-energize the gas valve and will make two more attempts to relight the burner. If the burner does not relight after the three trials the control will go into LOCKOUT as noted above in “Failure to light”. If flame is re-established, normal operation resumes.

Combustion airflow problems

If the airflow signal is lost, or the hi-limit switch (See Notice Page 12) opens during operation, the gas valve is immediately de-energized and the blower stays on. If the switch closes again, a normal ignition sequence will resume. If not, and if this condition persists for more than five minutes, the control will enter lockout with the blower off.

Diagnostics feature

If the unit stops operating normally, please check the LED indicator on the user panel. If the LED is on or blinking, the blinking pattern will notify you of the fault detected by the Control Board as follows:

- Steady On - Internal Control Fault
- 1 Flash - Air Fault
- 2 Flashes - Flame Detection Error
- 3 Flashes – Lockout
- 4 Intentionally 'NA' – Reserved for Future Diagnostics
- 5 Flashes - Low voltage

The blinking LED pattern will be repeated at intervals of three (3) seconds.

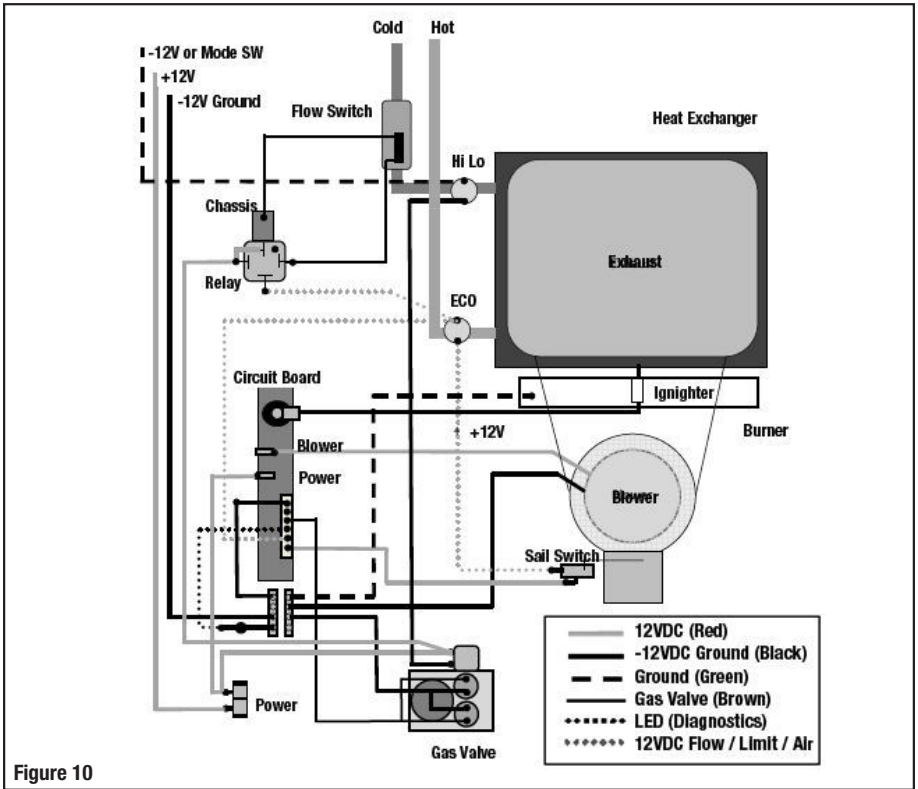
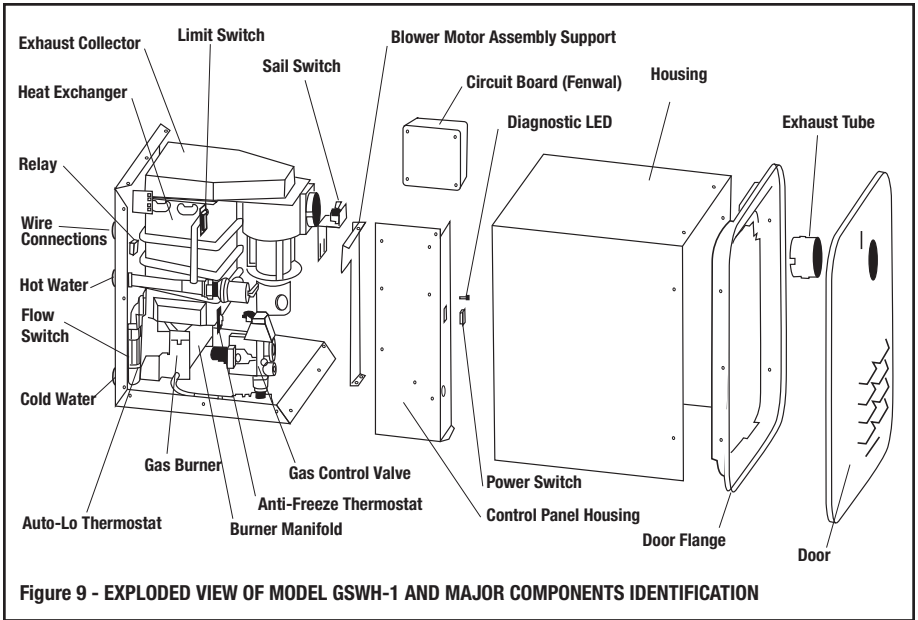

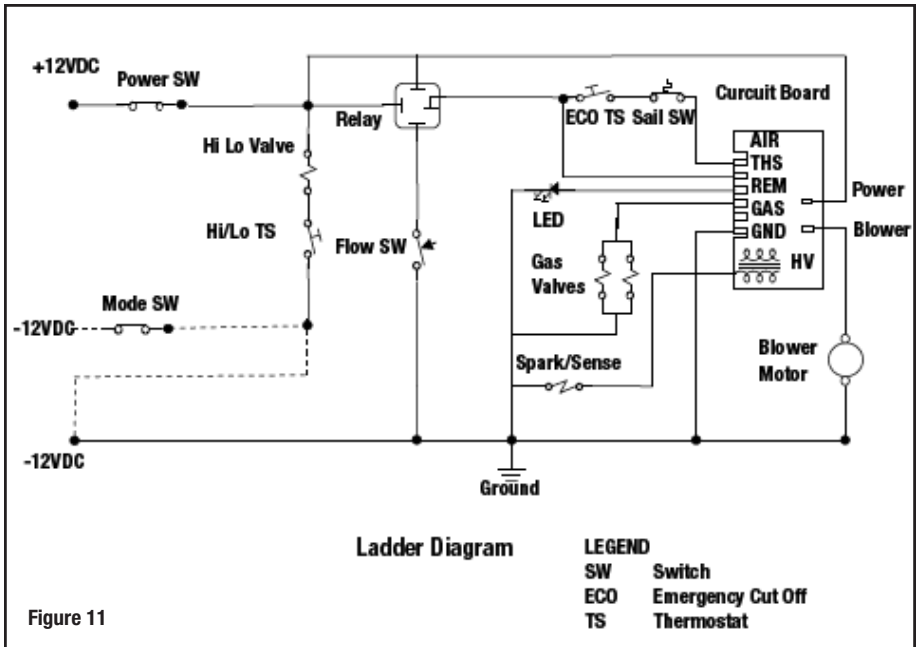

Figure 11

Specifications

The table below summarizes the main performance specifications of the Model GSWH-1.

BTU/HR	27,000 – 34,000
Fuel	Propane (LP Gas)
Inlet Pressure	10.5" WCI Min to 14" WCI Max
Manifold Pressure	8" – 10" WCI
Power Input	12VDC < 3 amp
Water Operating Pressure	125 PSI Max
Max Water Temperature	125 ° F
Dimension	Width: 12.5" - Height: 12.5" - Depth 15.5"
Shipping Weight	22 lbs

GIRARD PRODUCTS, LLC GSWH-1 WATER HEATER TWO YEAR LIMITED WARRANTY

Girard Products, LLC warrants to the original owner (purchaser) that this product will be free of defects in material or workmanship for a period of two years from the original date of purchase whether or not actual usage begins on that date. Girard Products liability hereunder is limited to the replacement of the part(s), repair of the part(s), or replacement of the product or part(s) with a reconditioned or new product/part(s) at the discretion of the Girard Products. This warranty is void if the product has been damaged by accident, unreasonable use, misuse, neglect, tampering or other causes not arising from defects in material workmanship. This limited warranty extends to the original owner of the product only, is not transferrable and is subject to the following conditions:

1. For a period of two years from the date of purchase, Girard Products will replace any parts that are found defective and will pay a warranty service allowance directly to the **recommended** Girard Products Water Heater Service Center at rates mutually agreed upon between Girard Products and its recommended service centers. As an owner, you are required to provide proof of purchase date through a Bill of Sale or other appropriate record.

2. Replacement parts will be shipped FOB the shipping point within the Continental United States, Alaska and Canada to the recommended service center performing such repairs. **All freight, shipping and delivery costs shall be the responsibility of the owner.**

3. Service calls to customer's location are not considered part of these charges and are, therefore, the responsibility of the owner.

4. Before having warranty repairs made, confirm that the service center is a recommended service center for Girard Products, LLC Water Heaters. **DO NOT PAY THE SERVICE CENTER FOR WARRANTY REPAIRS WITHOUT PRIOR APPROVAL FROM GIRARD PRODUCTS, LLC; SUCH PAYMENTS WILL NOT BE REIMBURSED.**

5. The defective parts (or water heater) become the property of Girard Products, LLC and may need to be returned to Girard Products Technical Support Department. Girard Products reserves the right to examine the alleged defective part or water heater. All returned parts and/or product must be individually tagged with the water heater's model, serial number, date of installation and detailed explanation of defect.

6. This warranty does not cover the following items classified as normal maintenance:

- Adjustment of gas pressure
- Cleaning or adjustment of flue
- Adjustment of pressure-temperature relief valve
- Cleaning, replacement, and adjustment of burner orifice

7. This warranty applies only if the unit is installed according to the installation instructions provided and complies with local and state codes.

8. The warranty period on replacement parts (or water heater) is the unused portion of the original warranty period or ninety (90) days, whichever is greater.

9. This limited warranty does not apply to damage caused by accident, abuse, misuse (including damage caused by service performed by anyone who is not a Girard Products LLC recommended installer), misapplication, alterations, modifications, water damage or freezing.

10. THIS WARRANTY AND THE REMEDIES SET FORTH ABOVE ARE EXCLUSIVE AND IN LIEU OF ALL OTHER WARRANTIES, REMEDIES AND CONDITIONS, WHETHER ORAL OR WRITTEN, EXPRESS OR IMPLIED. GIRARD PRODUCTS LLC SPECIFICALLY DISCLAIMS ANY AND ALL IMPLIED WARRANTIES, INCLUDING WITHOUT LIMITATION, WARRANTIES OF

MERCHANTABILITY AND FITNESS FOR A PARTICULAR PURPOSE. IF GIRARD PRODUCTS LLC CANNOT LAWFULLY DISCLAIM IMPLIED WARRANTIES UNDER THE LIMITED WARRANTY, ALL SUCH WARRANTIES, INCLUDING WARRANTIES OF MERCHANTABILITY AND FITNESS FOR A PARTICULAR PURPOSE ARE LIMITED IN DURATION TO THE DURATION OF THIS WARRANTY.

NO RESELLER, AGENT, OR EMPLOYEE IS AUTHORIZED TO MAKE ANY MODIFICATION, EXTENSION OR ADDITION TO THIS WARRANTY. GIRARD PRODUCTS LLC IS NOT RESPONSIBLE FOR DIRECT, SPECIAL, INCIDENTAL OR CONSEQUENTIAL DAMAGES RESULTING FROM ANY BREACH OF WARRANTY OR CONDITION, OR UNDER ANY OTHER LEGAL THEORY, INCLUDING BUT NOT LIMITED TO LOST PROFITS, DOWNTIME, INCONVENIENCE, GOODWILL, EXPENSES FOR TRAVEL, LODGING, DAMAGE TO OR REPLACEMENT OF EQUIPMENT AND PROPERTY.

11. Some states and provinces do not allow the exclusion or limitation of incidental or consequential damages or exclusion or limitations on the duration of implied warranties or conditions, so the above limitations or exclusions may not apply to you. This warranty gives you specific legal rights, and you may also have other rights that vary by state or province.

12. Replacement parts purchased outside of the original water heater warranty carry a 90 day limited warranty.

13. Girard Products provides no warranty for products installed or warranty claims originating outside the continental United States, Alaska, Hawaii and Canada.

Service

Your Girard Tankless Water Heater is manufactured to the highest standards and is designed to provide years of trouble free use but in the event you require service please follow the steps outlined below. Remember as an owner, you are required to provide proof of purchase date through a Bill of Sale or other appropriate record.

1. If your RV has its original water heater and is still under the RV manufacturer's warranty, follow the steps suggested by your dealer or the manufacturer of your RV.

2. Contact Girard Products Water Heater Service Center or call the Girard Products Technical Support Department at 949-259-4024 or visit our website at www.greenrvproducts.com for a local recommended service center.

3. Call the service center, describe your problem and make an appointment, if necessary. **SERVICE CALLS TO CUSTOMER LOCATION ARE THE RESPONSIBILITY OF THE OWNER. DO NOT PAY THE SERVICE CENTER FOR WARRANTY REPAIRS WITHOUT PRIOR APPROVAL FROM GIRARD PRODUCTS, LLC; SUCH PAYMENTS WILL NOT BE REIMBURSED.** Be sure to provide purchase documentation regarding your Girard Water Heater.

This Girard Products Water Heater is designed for use in recreation vehicles for the purpose of heating water as stated in the "rating plate" attached to the water heater. Any other use, unless authorized in writing by the Girard Products Engineering Department, voids this warranty.

GIRARD PRODUCTS, LLC

1361 CALLE AVANZADO, SAN CLEMENTE, CA 92673

949-259-4024 • www.greenrvproducts.com

WARRANTY/GSWH-1 (7/20/2010)
