

# **G-2000 PATIO AWNING**

# **G-1500 DOOR AWNING**

**INSTALLATION, OPERATION, ADJUSTMENT and REPAIR**  
**REV.01272016**



  
**GIRARD SYSTEMS®**

**RV AWNING PRODUCTS**

1361 CALLE AVANZADO, SAN CLEMENTE, CA 92673 (800) 382-8442 FAX (949)276-5500

[www.girardrv.com](http://www.girardrv.com)



**Intertek**  
**5000791**

|   |   |                                |
|---|---|--------------------------------|
|  <b>GIRARD SYSTEMS</b><br>1361 Calle Avanzado, San Clemente, CA 92673<br>Phone: (800) 962-8442 FAX: (949) 276-5600 |  | <b>MODEL:</b> XXXXXXXXXXXXXXXX |
| <b>INPUT:</b> XX VAC XXAmps XX WattsXXHz  | <b>Intertek</b><br><b>5000791</b>   | <b>SERIAL NO:</b> XXXXXXXXXXXX |
| <b>CAUTION:</b><br>TO PREVENT THE MOTOR PROTECTOR FROM TRIPPING DO NOT EXCEED 2 MINUTES OF OPERATION PER HOUR.  |   |                                |
| <b>ATTENTION:</b><br>POUR EVITER LA SURCHARGE DU MOTEUR, NE PAS UTILISER PLUS DE DEUX MINUTES PAR HEURE   |   |                                |
| Conforms to UL STD 325<br>Certified to CSA STD C22.2 No. 247  |   | <b>DATE:</b> XXXXXX            |

AWNINGS FITTED TO THIS VEHICLE;

MODEL \_\_\_\_\_ SERIAL No. \_\_\_\_\_

MODEL \_\_\_\_\_ SERIAL No. \_\_\_\_\_

MODEL \_\_\_\_\_ SERIAL No. \_\_\_\_\_

MODEL \_\_\_\_\_ SERIAL No. \_\_\_\_\_



## INSTALLATION INSTRUCTIONS



### WARNING

“To reduce the risk of electric shock the operator power is to be provided from a weatherproof junction box in the case of permanent wiring, as per 314.15 of the National Electrical Code, NFPA 70.”

To prevent the motor protector from tripping do not exceed 2 minutes of operation per hour.

ALL ELECTRICAL WORK MUST BE CARRIED OUT BY QUALIFIED PERSONNEL AND CONFORM TO APPLICABLE ELECTRICAL CODES AND STANDARDS.

- Turn off power before beginning any electrical work.
- Please consult your RV's wiring diagram to locate any wiring prior to any drilling or any installation procedures.
- Ensure that placement of controls, cables, and wires are not in any way obstructed. This can damage the components and obstruct electrical current.
- Use only certified components.



Girard Systems awnings may be operated in light wind and rain conditions. When periods of heavy rain and or high wind are expected the awning must be closed. Never leave the awning open and unattended.

**Damage caused by wind and rain is not covered by warranty.**

All awnings must be closed prior to moving the vehicle for any reason. As an extra safety precaution a visual check that every awning is fully closed is required.

**Damage caused by failure to comply with these instructions is not covered by warranty.**

Before using your awning, ensure that the area into which the awning will be deployed is free of obstructions (Trees, walls, pillars, posts, other vehicles etc.)

**Damage caused by collisions with any of the above or similar is not covered by warranty.**

Before using your awning make sure that all of your electrical circuits are operating correctly. Recreational Vehicles can generate AC power from three separate sources. The electrical system transfer switch in your vehicle will select power for the awning as follows:

**Shore Power** – if connected;

**Generator Power** – if the generator is running;

**Inverter Power** – batteries must be charged for inverter operation.

Girard Systems awnings are supplied with an electric motor appropriate to the product.



# CONTENTS

|   |       |
|---|-------|
| Basic System Overview .....               | 6     |
| Product Description .....                 | 8     |
| Tools Required .....                      | 8     |
| Installation instructions .....           | 9     |
| Unpacking .....                           | 11    |
| Layout, Mounting The Brackets .....       | 12-13 |
| Bracket Placement Chart .....             | 14    |
| Mounting The Awning To The Brackets ..... | 16-17 |
| Installation Of Coupled Awnings .....     | 18-22 |
| Weather-stripping Installation .....      | 23    |
| Anemometer Installation .....             | 24    |
| Motion Sensor .....                       | 25-26 |
| <u>Testing And Adjustments</u>            |       |
| Adjusting Motor Limit Switches .....      | 27-28 |
| Adjusting Elbow height and Pitch .....    | 29-30 |
| Testing The Anemometer .....              | 31    |
| Adjusting The Lead Rail .....             | 31    |
| Troubleshooting Guide .....               | 32-33 |
| <u>Common Repair Procedures</u>           |       |
| Motor Replacement .....                   | 34-36 |
| Fabric Replacement .....                  | 37-39 |
| Arm Replacement .....                     | 39-41 |
| Care And Maintenance Guide .....          | 42-43 |
| Technical specifications .....            | 44-45 |
| Technical Drawings .....                  | 46-49 |
| Component Identification .....            | 50-54 |

## **BASIC SYSTEM OVERVIEW**

**Your G-2000 and G-1500 Awnings consist of three main components:**

1. Mechanical system – consisting of:
  - The enclosure (or cassette) protects the fabric while closed.
  - The roller tube which is mounted within the cassette.
  - The top cover or fabric rolled onto the roller tube and connected to the lead rail that extends from the enclosure when the awning is opened.
  - The folding arms that supports the lead rail and the fabric.
  - The tubular motor which is mounted inside of the roller tube that allows the awning to extend and retract.
2. Electronic controls – to power and operate the motor
  - Anemometer (wind sensor) automatically retracts the awning in case of high wind that may damage the awning system.
  - Motion Sensor – This can be used in place of the anemometer.
  - G-Links model GC136 Motor Control (single motor) to power and operate the motor.
  - DC motor control.
  - Wireless Motor – This motor does not require a motor control.
3. User Controls – for awning operation



REMOTE  
HANDSET

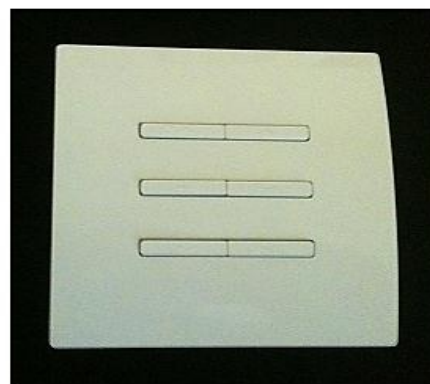

REMOTE WALL  
SWITCH

## 1. Programming the Remote Control

Wireless remote controls must first be programmed to your awning. Programming is usually done at the factory and the user will not usually need to program the remote control modules. If this should become necessary specific programming instructions are available for each remote control device.

## 2. Using the Remote Controls

G-Link hand held Remote Controls are available as a single channel or multi-channel devices (MAX 15 channels). If the device can operate more than one channel an LCD display will indicate the number of the channel that is currently selected. The remote control will have the capability to control every Girard System product installed on the vehicle.

- Operation of the remote control handset is achieved by use of the circular control pad below the LCD display. The function of each part of the control pad is illustrated in the photograph below.

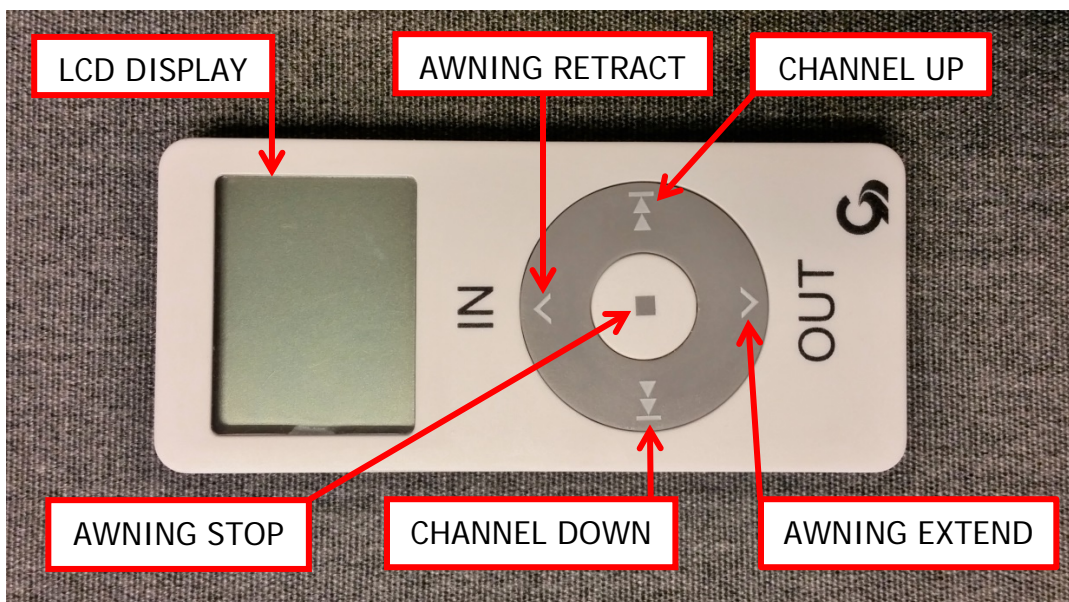

- The custom LCD display, when activated by pressing any of the above buttons, shows the active channel and the direction of motion.
- The operation of wall mounted switches is self-explanatory and normally UP indicates the RETRACT function and DOWN indicates the EXTEND function.





---

## **PRODUCT DESCRIPTION**

The G-2000 and G-1500 awning systems provide protection from the sun at a touch of a button. The G-2000 and G-1500 awnings are built to your specifications with the highest quality materials available, your units features:

- A standard motor that operates with a wireless motor control or a wireless motor that operates with an integrated motor control.
- An anemometer (wind sensor) or a Motion Sensor that will retract the awning to prevent damage from the wind.
- A hand held Remote Control
- A wall mounted Remote Switch
- Options include; electronic automation controls to ensure proper closing at all times, a control to retract all awnings when the vehicles' motor is started, and more....

The G-2000 and G-1500 awnings controls use an RF (radio frequency) link to communicate with each other. This simplifies the installation and maintenance by removing the need for extensive wiring. This RF network is called the G-Link system. For more information please refer to the relevant manual that was included with the awning. All necessary power cables are supplied with this product.

## **TOOLS REQUIRED:**

- Electric Drill
- Tape measure
- (2) ladders
- Chalk line
- Flat head screwdriver (small)
- Phillips screwdriver
- Caulking gun
- (2) tubes silicone caulking
- Drill bits: 1/8", 3/8", and 7/16"
- Allen wrenches: 5mm and 4mm
- Open-end wrenches: 10mm, 19mm
- Keyhole saw





---

**FOR PERSONAL SAFETY AND QUALITY OF INSTALLATION, A MINIMUM OF TWO INSTALLERS IS RECOMMENDED FOR THIS PRODUCT.**

Before beginning to install the awning please verify the following;

- The vehicle is parked and leveled on suitable hard standing.
- Suitable precautions have been taken to protect the vehicle from accidental damage.
- The area of the vehicle where the awning is to be installed has been prepared.
- Sufficient manpower, a minimum of 2 persons is required.
- Suitable protective clothing is worn by the persons doing the installation.
- Suitable and serviceable lifting and holding equipment should be used to avoid personal injury.
- When mounting fixtures to the vehicle be aware that the soft materials that the skin of the vehicle is made from can be torn out or "Stripped" by the over tightening of fasteners.

**DO NOT OVER TIGHTEN FIXING BOLTS AND SCREWS.**

- Make every effort to ensure that fasteners are mounted to the structural framework of the vehicle not just the skin.
- Any holes made in the skin of the vehicle must be sealed with silicone sealant, putty tape or similar product.



## **BEFORE INSTALLATION:**

1. Insert end of crank into manual override receiver, located at extreme end of awning.
2. Push in and rotate handle 1/4-turn clockwise. Let handle drop approximately 1/2". (Handle should lodge in receiver and awning may now be extended/opened.)
3. Extend awning approximately 12" by turning handle clockwise (see Fig. 1); confirm that awning shoulders are in proper locations; make note of shoulder locations; and retract/close awning by turning handle counter-clockwise.

**NOTE: Roof mount awnings will have the manual override receiver positioned on the top of the awning.**

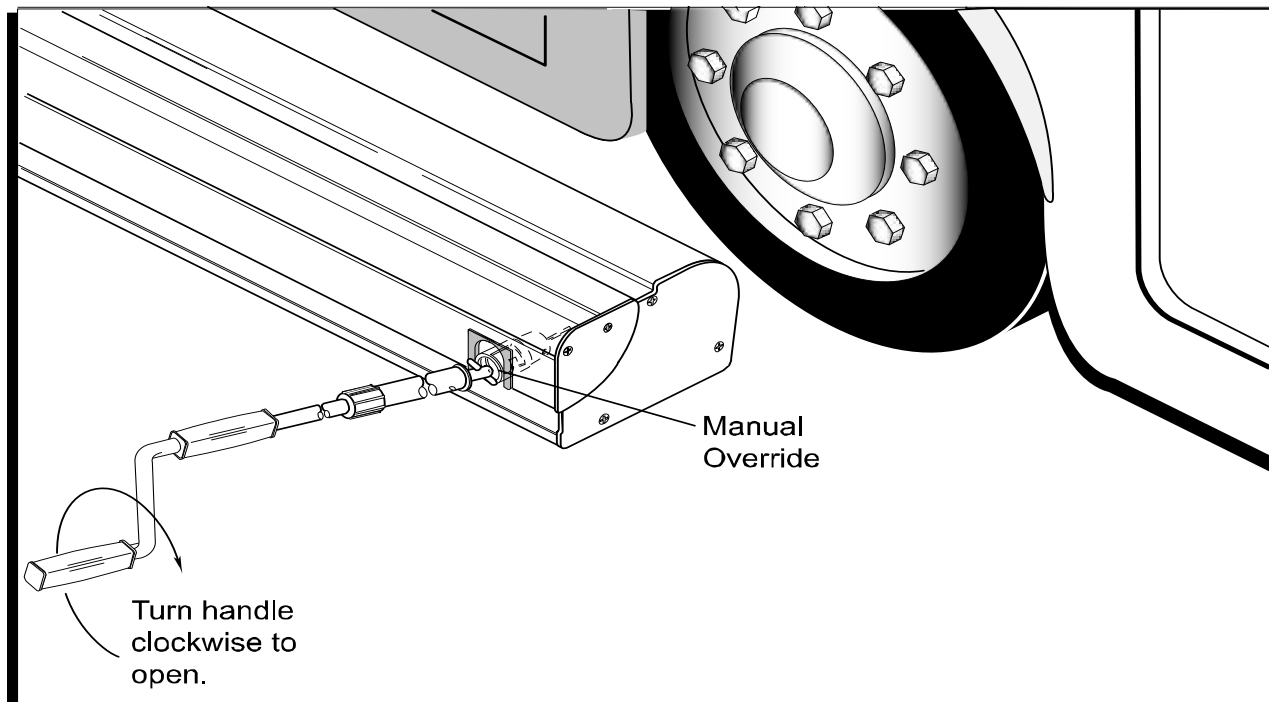

(FIGURE 1)

**NOTE: FOR PERSONAL SAFETY AND QUALITY OF INSTALLATION, TWO INSTALLERS ARE RECOMMENDED FOR THIS PRODUCT.**

## **UNPACKING**

1. Before starting any of the installation procedures unpack the awning and inspect the product for any possible damage that may have occurred during shipping.
2. If any damaged or missing parts have been discovered please call Girard Systems TOLL FREE on 800-382-8442 between 7:30am and 5:00pm P.S.T.
3. Before starting any of the installation procedures review the length and motor placement of your awning for accuracy.
4. When it has been determined that the product is satisfactory, remove the mounting brackets and place the awning in a safe location while preparing the RV.
  - a. To remove the brackets locate the slide lock that retains the bracket to the housing. (Figure. 2)
  - b. Using a 5mm Allen wrench, loosen the set screws on the slide locks.
  - c. Once the set screws have been loosened the slide locks should slide freely, clear the slide lock away from the bracket.
  - d. The bracket can now be removed.

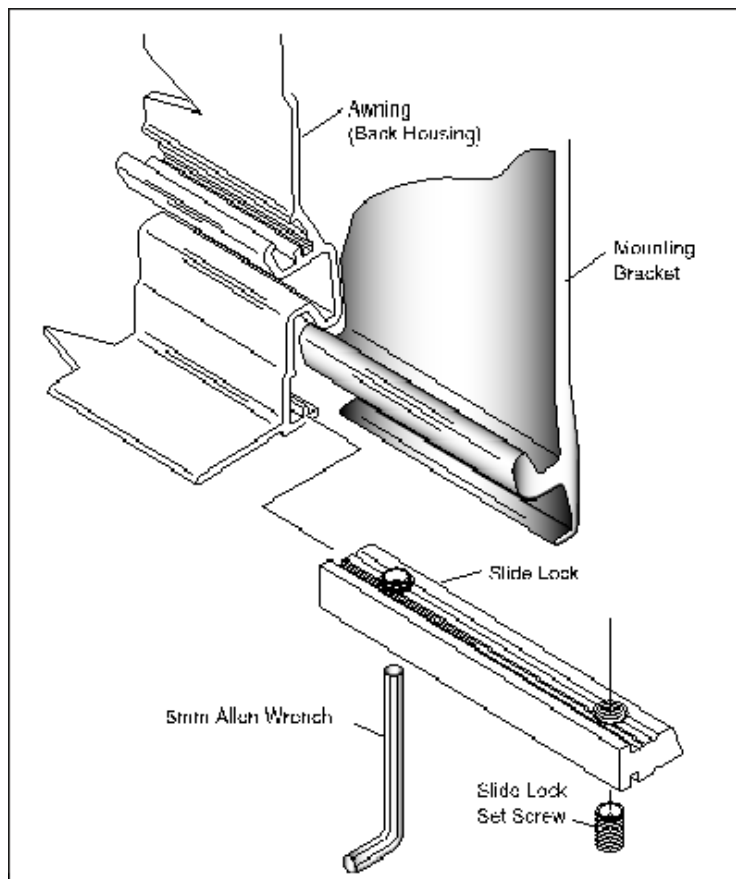

(FIGURE 2)



## **LAYOUT, MOUNTING THE BRACKETS**

**A. ROOFMOUNT APPLICATION – NOTE: The clearance needed for roofmount application of the NOVA varies by manufacturer. The shape of the roof, the depth of installation, type of roofmount bracket used and all other factors should be taken into consideration when installing this product. Please consult Girard Systems if there are any questions regarding the awning installation.**

1. When using the roofmount application, roofmount brackets can be ordered through Girard Systems or they can be locally manufactured. These brackets will be used in conjunction with the mounting brackets supplied with the awning.
2. Determine the exact position for the final installation of the awning.
3. Roofmount brackets must be installed within 2" of the ends of the awning. Once you have determined the location of the 2 end brackets snap a chalk line between these points to ensure alignment of the installation. This line is to be used as a reference to install the smaller middle bracket at a later time.
4. To find the location of the smaller middle bracket please refer to the chart on the following page. **NOTE: The location of the middle bracket must fall directly centered behind the shoulder of the middle arm. Failure to follow these instructions will void the warranty of this product.**
5. Now that the bracket locations have been determined, using the bracket as a template, mark the holes for mounting the bracket to the vehicle. **NOTE: It is up to the installer to find adequate structure to securely fasten the roofmount brackets to. All caution must be taken to weather seal all installation perforations. Failure to do this could result in damage to the vehicle.**
6. With the roofmount brackets now correctly fitted the awning mounting brackets can be installed. Using the hardware kit (7/16" carriage bolts) supplied with the awning, fix the mounting bracket to the roofmount brackets through the pre-aligned holes.
7. Before installation of the awning, determine the position of the motor and calculate the best place to make the 7/16 inch hole for the motor power supply cable.

**NOTE: Please consult your RV's wiring diagram to ensure that no wiring will be damaged while drilling the hole.**



**B. SIDEWALL APPLICATION – NOTE: Please take into consideration all possible clearances, and obstacles before installing this awning. Items such as slide rooms, etc. vary from one manufacturer to another. Please consult Girard Systems if there are any questions regarding the awning installation.**

1. The mounting brackets and hardware used for this application are included with the awning.
2. Taking all dimensions into consideration, determine the exact location for the final position of the awning.
3. Mounting brackets must be installed within 2" of the ends of the awning. Once you have determined the location of the 2 end brackets snap a chalk line between these points to ensure alignment of the installation. This line is to be used as a reference to install the smaller center bracket at a later time.
4. To find the location of the smaller center bracket please refer to chart on the following page. NOTE: The location of the center bracket must fall directly centered behind the center shoulder location. Failure to follow these instructions will void the warranty of this product.
5. Now that the bracket locations have been determined, using the bracket as a template, mark the holes for mounting the bracket to the vehicle.
6. Using a 1/8" bit (8" long), pilot drill the centers of the marked holes. Inside of the RV verify the locations of the backing plates. NOTE: Please consult the RV's wiring diagram to ensure that no wiring will be damaged while drilling the hole.
7. Pre-drill six 7/16" holes per mounting bracket through the pilot holes.
8. Apply a liberal amount of silicone caulking around each hole before installing the brackets.
9. Install the 2 outer brackets, and then the center bracket (if required) with six 7/16" carriage bolts, washers, nylon nuts and two 2 backing plates per bracket. (Figure 3) Tighten bolts and then apply silicone caulking to the top edge and both sides of each bracket.
10. On the motor side of the awning drill a 7/16" hole for the awning motor cable to enter the RV near the electrical source. Position the hole 1" to the left or right of the bracket depending on the location of the motor. Do not drill hole higher or lower than the bracket. This will ensure that it will not be seen after the awning is installed.

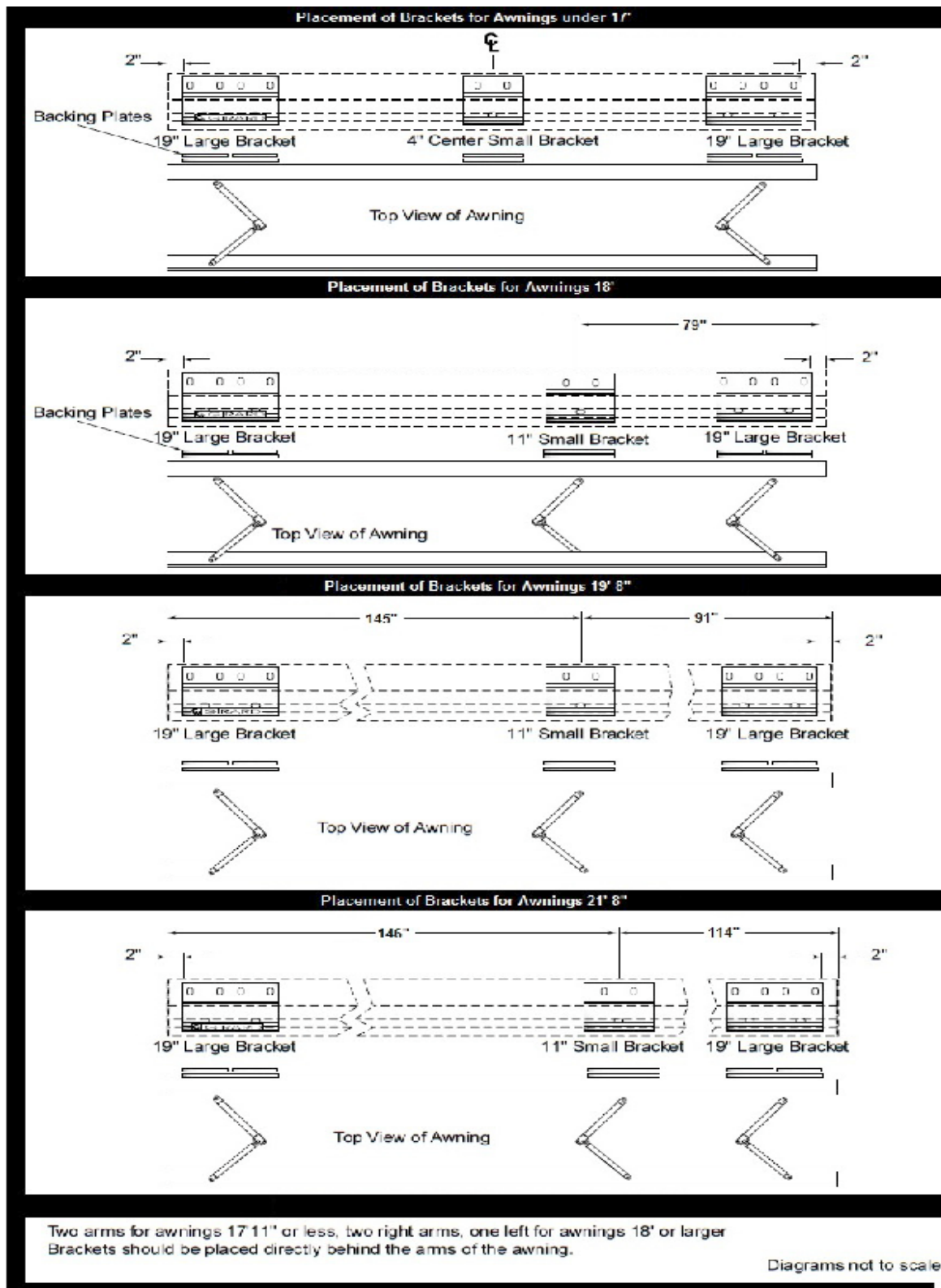

11. If a 12V Motion Sensor is to be fitted, locate the wire and then drill the appropriate sized hole to route the wire to an interior 12V source. Make sure to seal any perforations made in the shell of the vehicle.
12. Locate the white wire grommet supplied with the awning. Place a fine bead of silicone around the body of the grommet. Slide grommet into the 7/16" hole previously drilled for the motor wire.

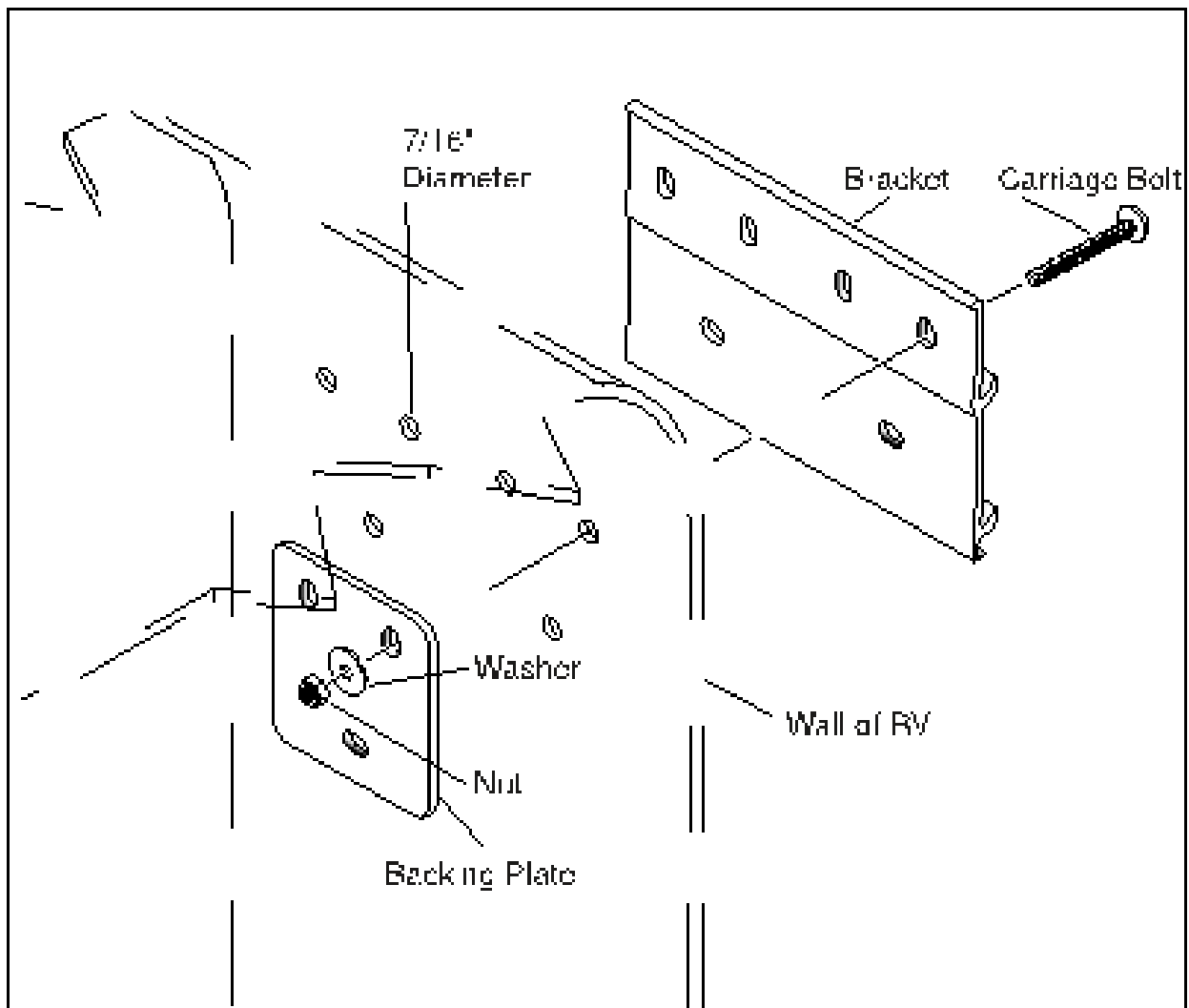

(FIGURE 3)



## **MOUNTING THE AWNING TO THE BRACKETS**

1. Lift the awning into position for installing the awning on the brackets.
  - a. Ladders are usually sufficient; however, a scaffold or forklift may be used.
  - b. If using a forklift use all necessary caution to protect the surface of the awning. Lift from the center of the awning to maintain product balance while elevating.
2. Place the awning onto the mounting brackets (Fig. 4 #1) while feeding the motor wire through the white motor grommet. A small amount of lubricant may aid the feeding of the wire. Make sure the grooves (Fig. 4 #2) of the awning are securely engaged into the channels on the bracket. (Figure 4)

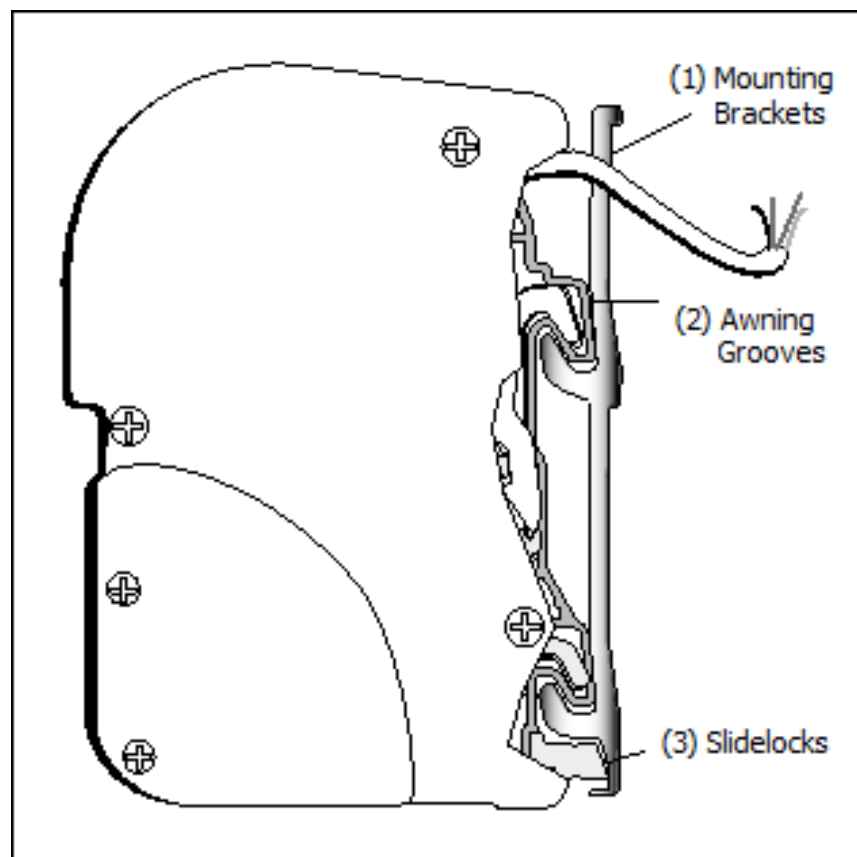

(FIGURE 4)

3. Secure the awning by moving the slide locks (Fig. 4 #3) along the bottom awning track until they are located under their respective brackets. The final position of the slide lock should be directly under the shoulder of the arm.
4. Once the final location of the slide locks has been achieved, tighten both set screws on each slide lock with a 5mm Allen wrench.

5. One of the slide locks must have a grounding bolt fitted as shown in photo 1 below. This is to provide a safe passage to ground in the unlikely event of an electrical short between the motor and the awning cassette. The grounding bolt when tightened should be in contact with both the mounting bracket and the bottom of the awning cassette. The other part of the grounding circuit is an earth bonding lead, which can be found by removing the end plate nearest the motor as shown in Photo 2 below.



Photo 1

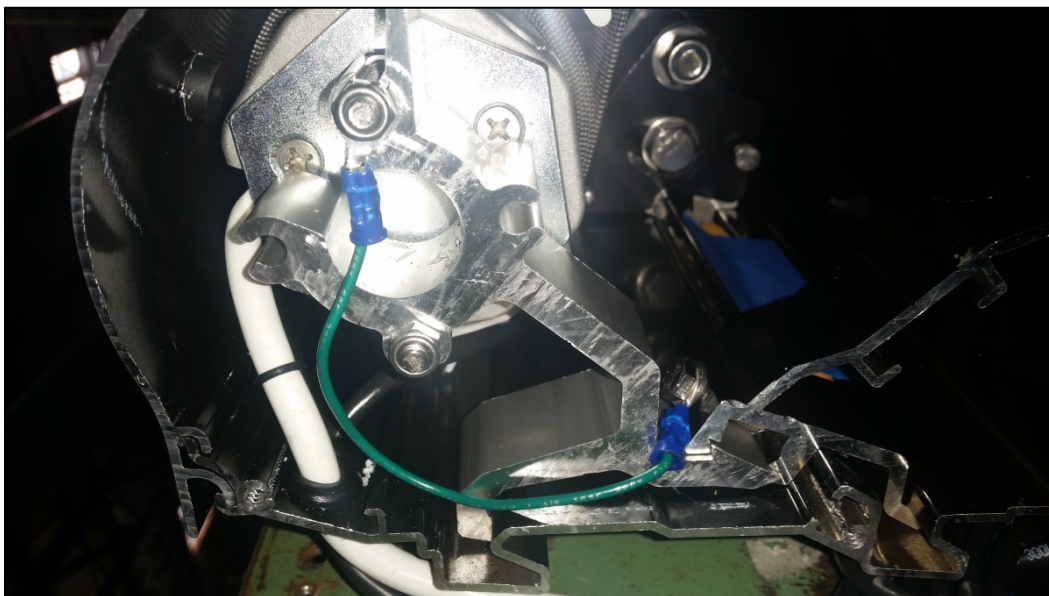
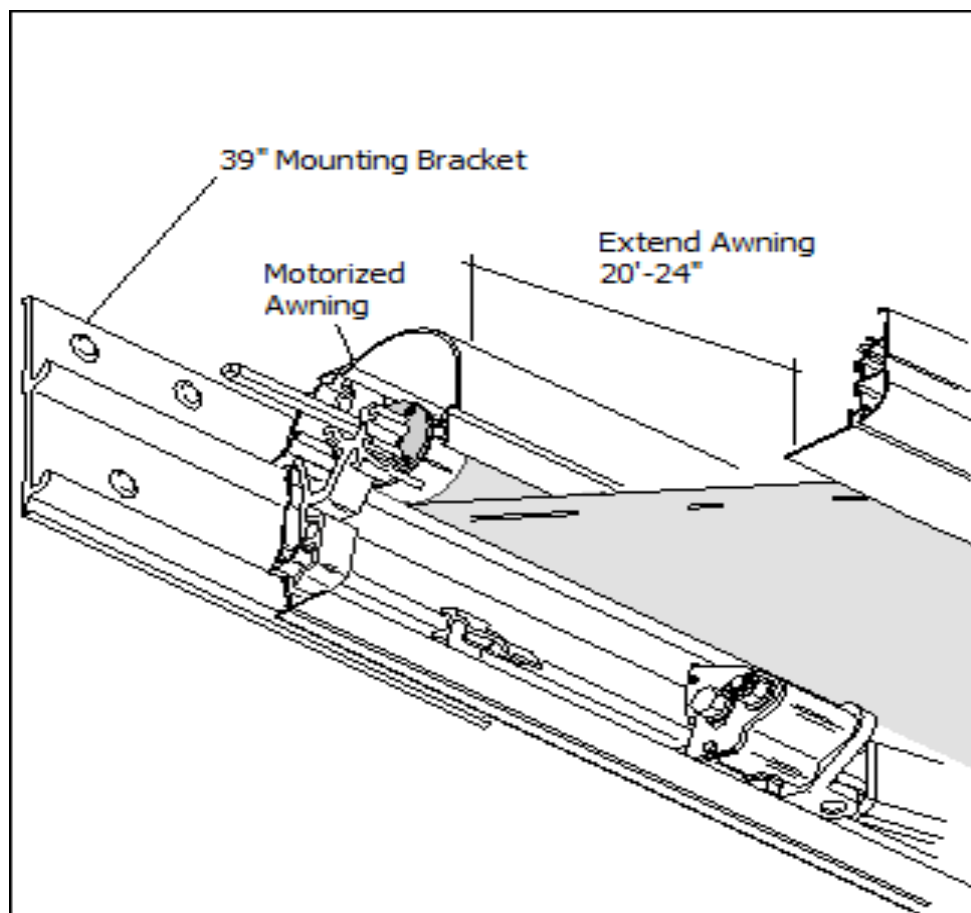

Photo 2



# **INSTALLATION INSTRUCTIONS FOR COUPLED AWNINGS**

1. The 19" end brackets are installed 2" from the overall length of the awning. The 39" mounting bracket is located in the center, at the junction of the two awnings. Additional brackets need to be located behind, and centered on the arms of each awning.
2. After all the mounting brackets are firmly attached; place the motorized awning on the mounting brackets. Place the slide locks under each plate, but do not tighten. A fourth slide lock should be on the awning. This lock will be placed between the two awnings once they are mounted. (Refer to Figure 6 on the next page.)
3. Extend the motorized awning 20"-24". Temporarily install the controller to the motor and use the remote control.



(FIGURE 5)



**NOTE: Do not remove the plastic from the non-motorized awning. Move the plastic away from the area in contact with the mounting bracket.**

4. Hang the non-motorized awning on the mounting brackets so it aligns up to the drive shaft of the motorized awning. The slide locks should now be positioned on the brackets and should not be locked to allow awnings to slide together freely. (See Fig. 6)
5. Extend the non-motorized awning by 20" to 24". To do so, use heavy cord or straps on both ends of the awning to encircle the awning box, using enough to allow the outward movement of the awning lead rail. CAUTION: The arms are under extreme spring pressure. Once the plastic is cut, the lead rail will instantly extend from the box! After the cord/straps are tied securely around the awning box, carefully remove the plastic. The lead rail will then extend to the length of the cord/straps. (See Fig. 6)

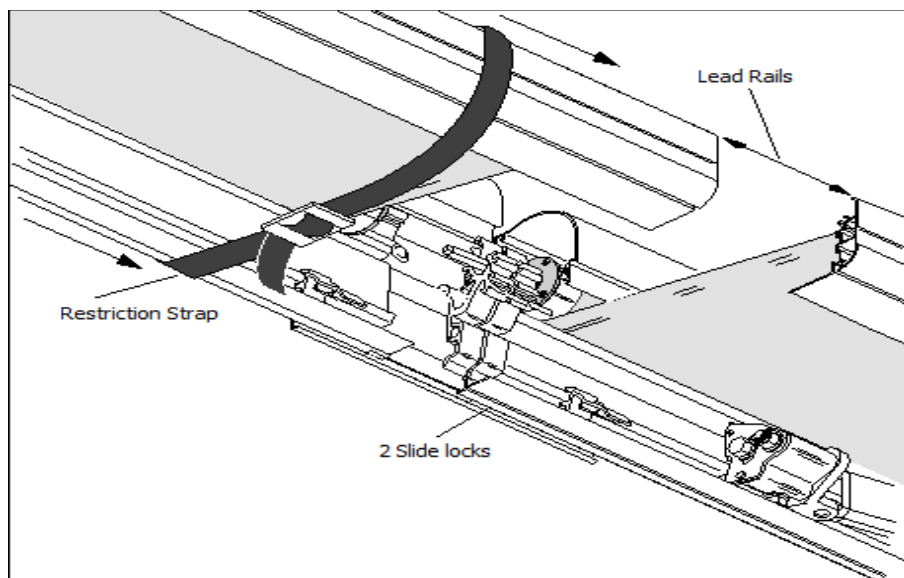

(FIGURE 6)

6. Extend the motorized awning past the non-motorized awning by about 8". This will allow the non-motorized awning with loose fabric to catch-up. Next align the black marks on gudgeons or align the poly ropes of the non-motorized awning with the motorized awning.

These adjustments are to be made with the motorized awning, still keeping the motorized awning ahead of the non-motorized. Once the alignment has been done



slide the awnings together. Then tighten all of the slide locks. Including the one positioned in between both awnings. (See Fig 7)

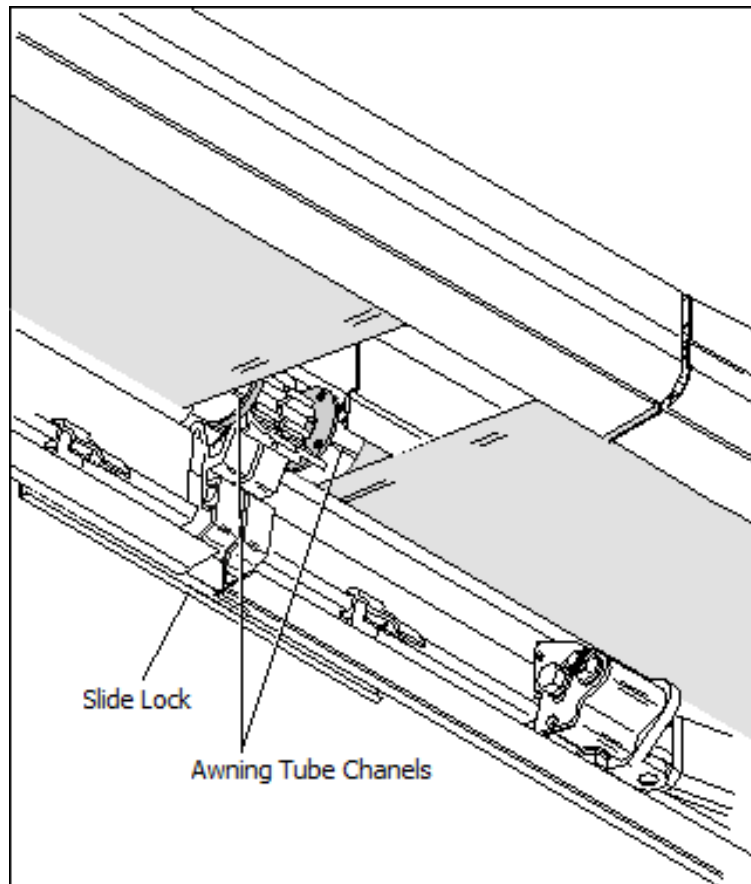

(FIGURE 7)

7. Remove the cord/straps from the non-motorized awning. Extend the coupled awnings. The fabric should be tight on both sides; if the motorized side is tighter, the awnings must be realigned. See note on the last page for the realignment procedure.
8. Adjust the awnings for equal pitch and lead rail adjustment. (Refer to the Adjustments section of this manual)
9. Move the lead rail guides away towards the center and make room to insert the lead rail connector. The lead rail connector is installed in the lead rails. Center the connector bar between the two awnings (approximately 8¾" per side). Remove the two Phillips screws and drill one 9/64" hole into the lead rail using the lead rail connector as your template. Insert and tighten the one Phillips



screw and then tighten the hex screw on the same side. Draw the lead rails together until they are joined and flush in the center. Using the attached lead rail connector as your template drill a second  $9/64$ " hole and tighten the other Phillips screw. Tighten the remaining hex screw. (Figure 8)

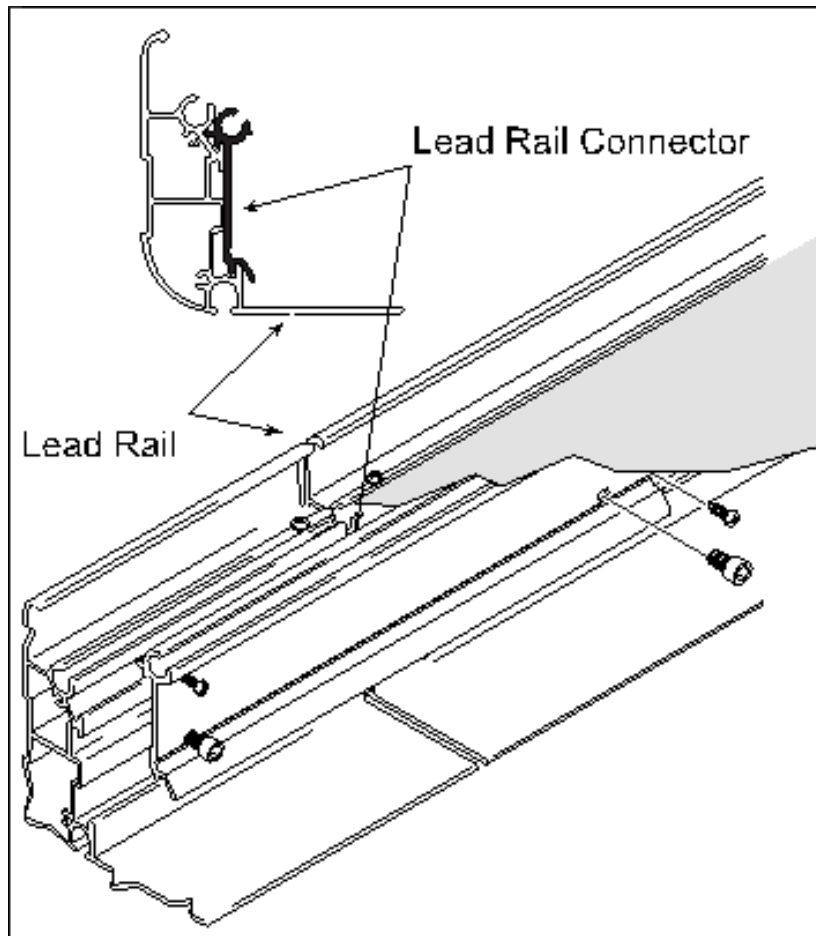

(FIGURE 8)

10. At the juncture of the two awnings inside of the cassette are two glide angles. Move the right glide angle 9" from the center and tighten until secure. (The awning should be open about 24"–36" when performing this function.) With the removable bracket on the right, slide the fabric onto the roller tube and roll the fabric over the TOP of the roller tube.
11. With the fabric on the roller tube, insert the fabric end into the lead rail connector. Slowly unroll the fabric until you are up to the awning box. Place the right side into the glide angle that you tightened down in step 10. (Figure 9)





12. Turn the left-hand side of the center roller tube towards the TOP (counter-clockwise) 13 complete rotations to tighten the spring. Place the left glide angle over the left side of the center roller tube to hold it in place, and tighten down the left glide angle. (Figure 10)
13. Extend the awning to its full projection. If you have excessive sag in the center roller fabric, repeat step 12 and add additional rotations.

**NOTE: If the awnings do not align after completing step 7, release the tension on the fabric using manual override. Then go to the end of the non-motorized side and remove the side plate and the roller tube support bracket (Part #15 in the parts list). Pull the roller tube out of the middle insert and realign on the gudgeon or the poly cord. Reassemble the awning and repeat steps 8–13. Readjust motor limits per this Installation Manual.**

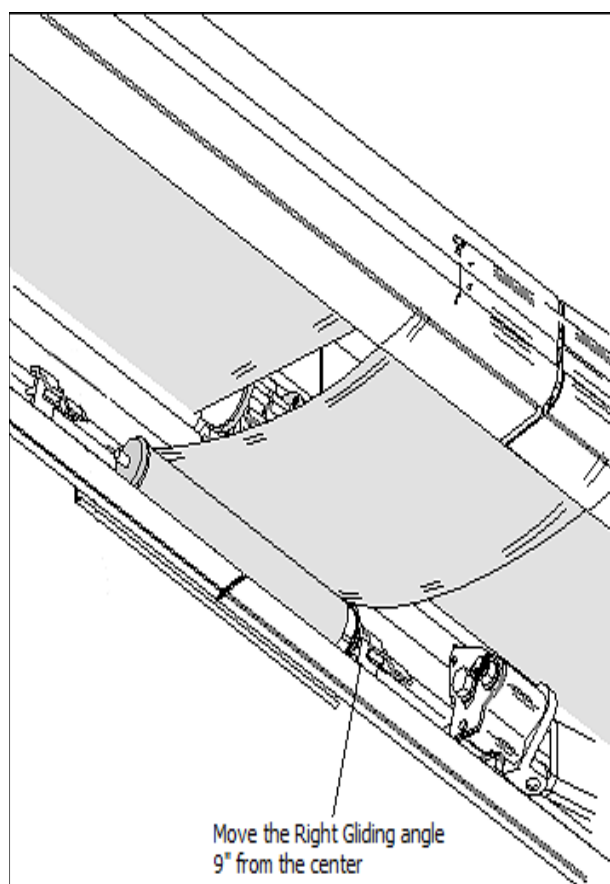

(FIGURE 9)

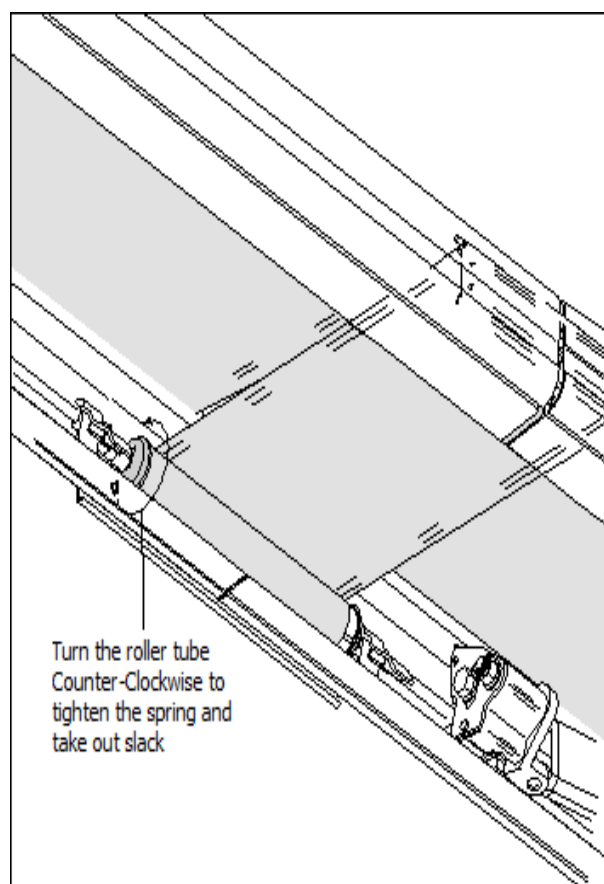

(FIGURE 10)



# WEATHERSTRIPPING INSTALLATION

(SIDEWALL APPLICATION ONLY)

1. Trim weather stripping to the length of the awning and remove any overhang.
2. Make a small cut in the weather stripping to allow for the motor cord.
3. Apply generous beads of silicone where indicated in Figure 11
4. Push weather stripping firmly into place.
5. Wipe off excess silicone.

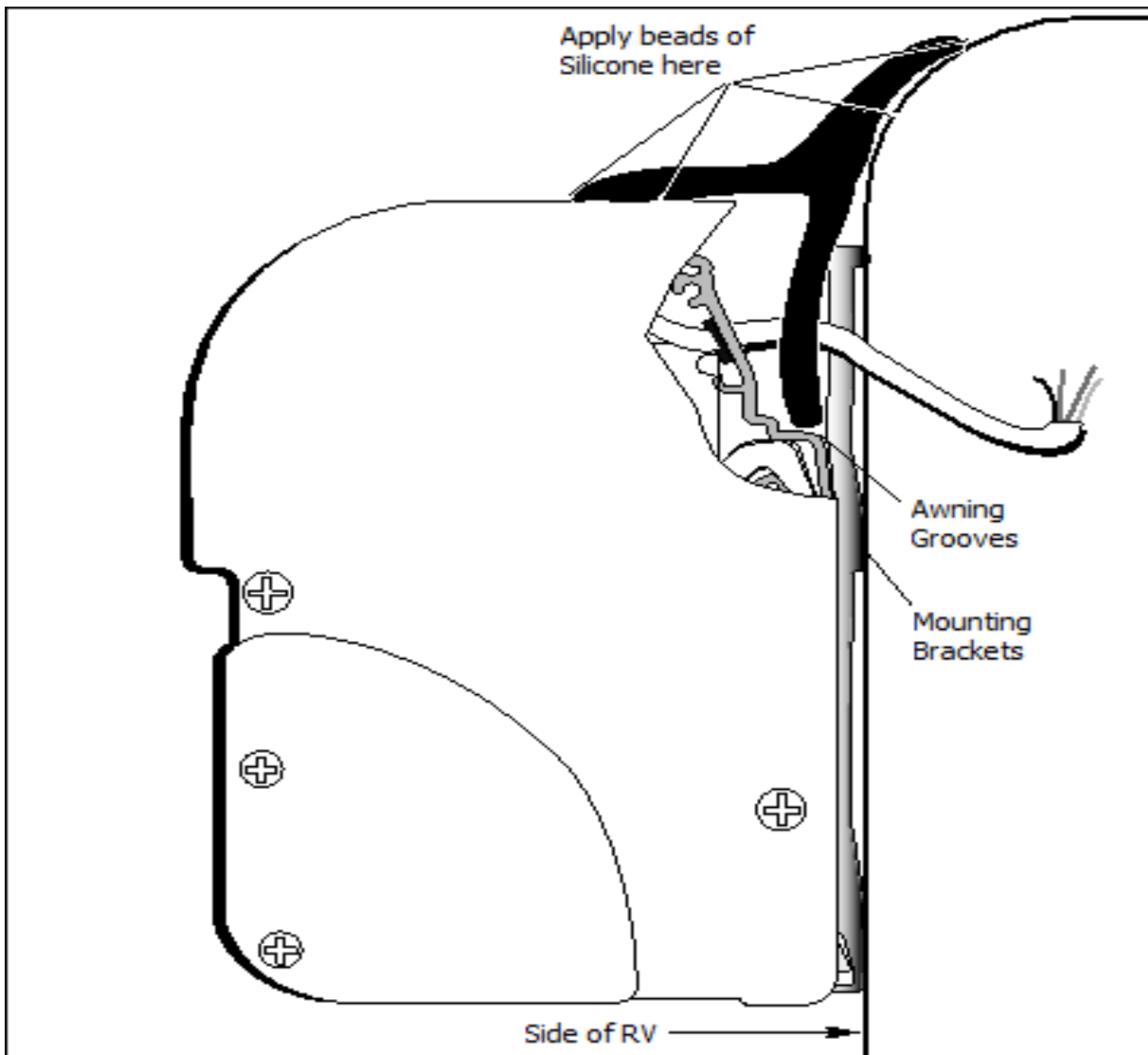

(FIGURE 11)

## **ANEMOMETER** – (Hardware Installation Only)

Place the anemometer on the roof of the vehicle. The unit can be mounted to a horizontal, vertical, or an inclined surface. The rotor of the anemometer must be pointing down. (Figure 12)

1. Position anemometer as follows:
  - a. On and parallel to the roofline
  - b. Near the awning to ensure the wind speed is measured accurately
  - c. Away from all obstructions (air conditioners, storage pods, etc.)
  - d. Orientate the cups of the anemometer to the rear of the coach.
2. The anemometer operates remotely by sending a retract signal to the motor control system of the awning.
3. The anemometer must have 12v DC power at all times when the awnings are extended. The minimal power consumption will not affect the charge of the batteries in any appreciable way.
4. If there is a suitable source of 12v DC power located on the roof then penetrating the shell of the vehicle will not be necessary.
5. The power cord extends from the base of the unit and is suitable for outdoor use.
6. To obtain power from inside the vehicle a hole must be drilled for the Power cable.
7. Drill the hole directly below where the power cord exits the anemometer base.
8. Feed anemometer cord through the hole, leave 3-4" of slack.
9. Apply silicone around the wire to prevent any water intrusion.
10. Apply a bead of silicone where the footprint of the anemometer will be installed.
11. Mount the anemometer with two (2) screws. Silicone the perimeter of the base.

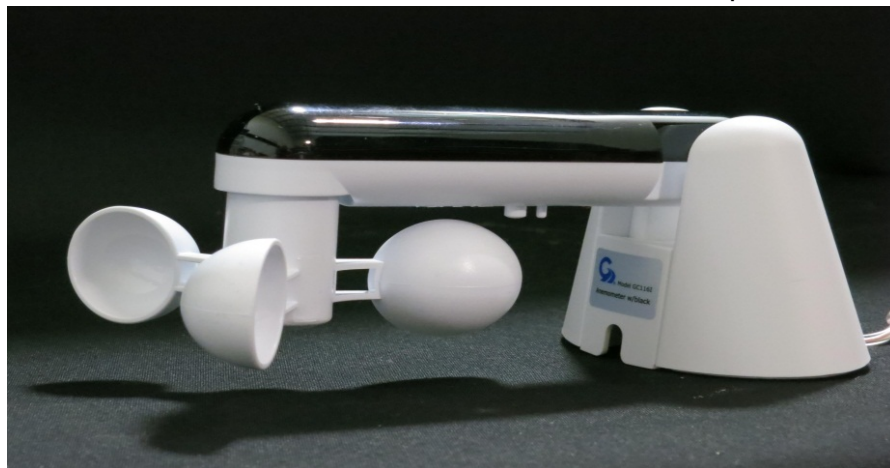

(FIGURE 12)

## **MOTION SENSOR (GC779G)**



The Motion Sensor can be used in place of the Anemometer in your electronics system. The GC779G requires a hard wired 12v DC power supply. The Module will usually be preprogrammed; replacement or retrofitted modules will need to be programmed to the vehicle's existing awning control systems. Instructions on how to do this can be found in the GC779G Motion sensor manual.

1. If there is access to a 12v DC power source on the roof of the vehicle it will not be necessary to make additional holes in the vehicle, if not then a hole must be drilled for the power cable. Locate the cable at the back of the awning cassette and the nearest source of 12v DC power.
2. Drill the appropriate sized hole, feed the wire to the interior of the vehicle and connect to the 12v DC power source.

The Motion sensor must be mounted on the inside of the lead rail of the awning that it is intended to control in a position where it will not be damaged when the awning is fully closed.

The cable of the Motion sensor is connected by means of a water resistant connection as shown in the photographs below.



A.



B.



C.

Once connected the cable should be tied and secured neatly to the awning lead rail.





# **TESTING AND ADJUSTMENTS**

## **OVERVIEW**

- A. Adjusting Motor-limit switches
- B. Adjusting elbow height and Pitch.
- C. Testing Anemometer (Wind Sensor)
- D. Adjusting Lead Rail

## **TOOLS REQUIRED**

Black plastic key provided with awning, or 4mm (5/32") Allen wrench.

## **ADJUSTING MOTOR LIMIT SWITCHES**

NOTE: The motor limit switches have been adjusted to the correct position at the factory prior to shipment. The awning motor is set to stop the exact moment the awning box closes. The fabric should be taut, the arms should be slightly bent, exposing a 1/8" gap at the elbows when fully extended.

Always check the motor limits after installation to ensure that the awning opens and closes correctly. Awning fabric can stretch over time, this will require an adjustment of the OUT limit switch.

**IMPORTANT: EXTREME CARE SHOULD BE TAKEN TO ENSURE THAT THE MOTOR LIMIT TURNS OFF AT THE EXACT MOMENT THE AWNING BOX CLOSES. FAILURE TO DO SO WILL CAUSE THE MOTOR TO RUN WHEN THE AWNING IS CLOSED. THIS WILL SUBSTANTIALLY REDUCE THE LIFE OF THE MOTOR.**

1. The AC motors used in Girard Systems awnings are reversible. Any references made to the motor limit switches in these instructions are based on the right-hand placement of the motor. For left hand placement, simply reverse the instructions. (Figure 8)
2. The motor has limit settings for both OUT (extension) and IN (retraction).
3. Adjust the limit switches with the black key provided with the awning, or use a 4mm (5/32") Allen wrench.



4. Extend the awning a few feet to gain access to the motor. Locate the motor (standard installation is on the right hand side of the awning). The limit adjustment holes are located on the head of the motor. Using the symbols printed next to the adjustment holes, turn the black key (or 4mm Allen wrench) to make the necessary adjustments. Typically the motors are labeled with a + or a -. (Figure 7)

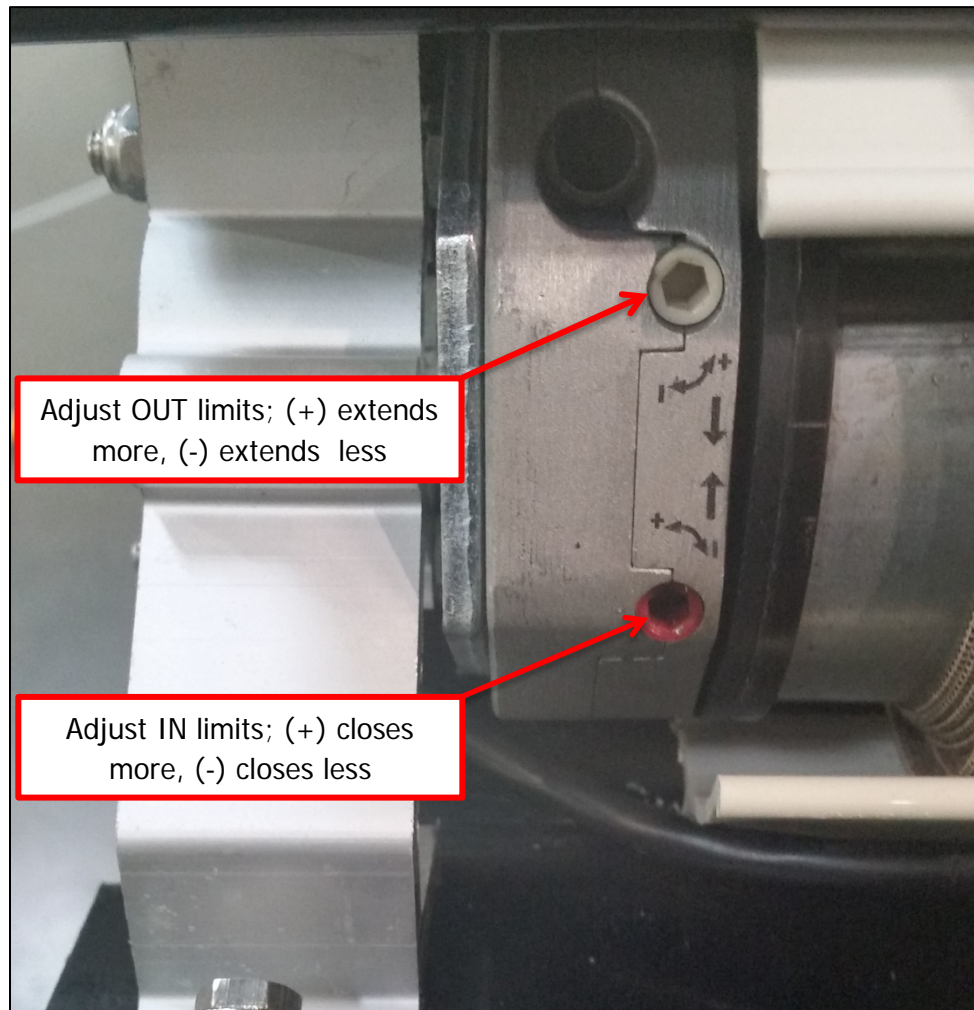

(Figure 16)

5. Approximately  $\frac{1}{4}$  turn of the adjustment screws represents about 1" of awning movement. NEVER set outward limits so that the fabric is slack with full arm extension. For proper adjustment set limit switch to stop the motor just before the arms lock. This will expose about a  $\frac{1}{8}$ " gap at the elbow.



## **ADJUSTING ELBOW HEIGHT and PITCH**

**NOTE; Adjustment of the Elbow height and pitch, will affect the height of the awning lead rail when it is fully deployed. Ensure that when making any of these adjustments the final height of the lead rail is no less than 7' (84").** This adjustment is usually required after an arm replacement. Also if the elbow of the arm hits the bottom of the casing as the lead rail closes.

### Tools Required

- 19mm (3/4") open-end wrench
- 10mm (3/8") open-end wrench

### A. ELBOW HEIGHT

1. Extend the awning about 18"
2. On the selected arm, loosen the two (2) nylon nuts on the side of the upper arm connection, using a 19mm open-end wrench.
3. Locate the smaller adjustment bolt located directly below the rear lock nut loosened in step #2. (Figure 17) Using a 10mm open-end wrench, rotate the bolt clockwise to TIGHTEN and raise the arm location inside the cassette. Rotate the bolt counter-clockwise to LOOSEN or lower the arm location inside the cassette.

NOTE: After retightening the nylon nuts, the arms will raise slightly higher.

4. Tighten the 2 nylon nuts located on the side of the upper arm connection.
5. Close the awning completely to ensure a proper fit.

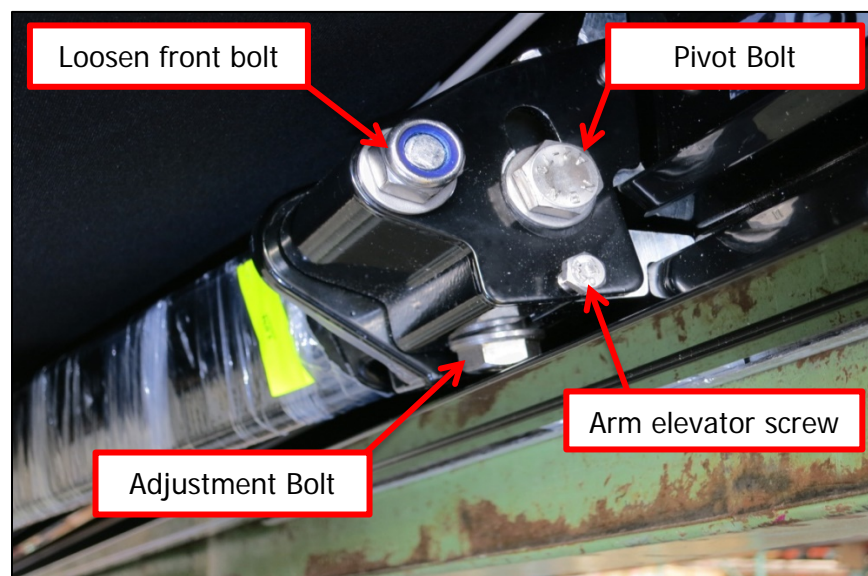

(Figure 17)



## B. ADJUSTING PITCH

**NOTE: The G-2000 and G-1500 Awnings will have the pitch adjusted according to manufacturer specifications. Please note the position of the pitch and DO NOT overtighten. This may damage the awning.**

1. Extend the awning about 18"
2. On the arm selected, loosen the 2 nylon nuts on the upper side of the arm connection using a 19mm open-end wrench.
3. Locate the larger adjustment bolt located on the bottom of the upper arm connection. (Figure 18) Using a 19mm open-end wrench rotate the bolt counter-clockwise to LOOSEN or lower the pitch. If the pitch is lowered too far Turn the bolt clockwise or TIGHTEN to raise the pitch.

**DO NOT OVERTIGHTEN.**

4. Tighten the 2 nylon nuts located on the side of the upper arm connection.
5. Close the awning completely to ensure a proper fit.

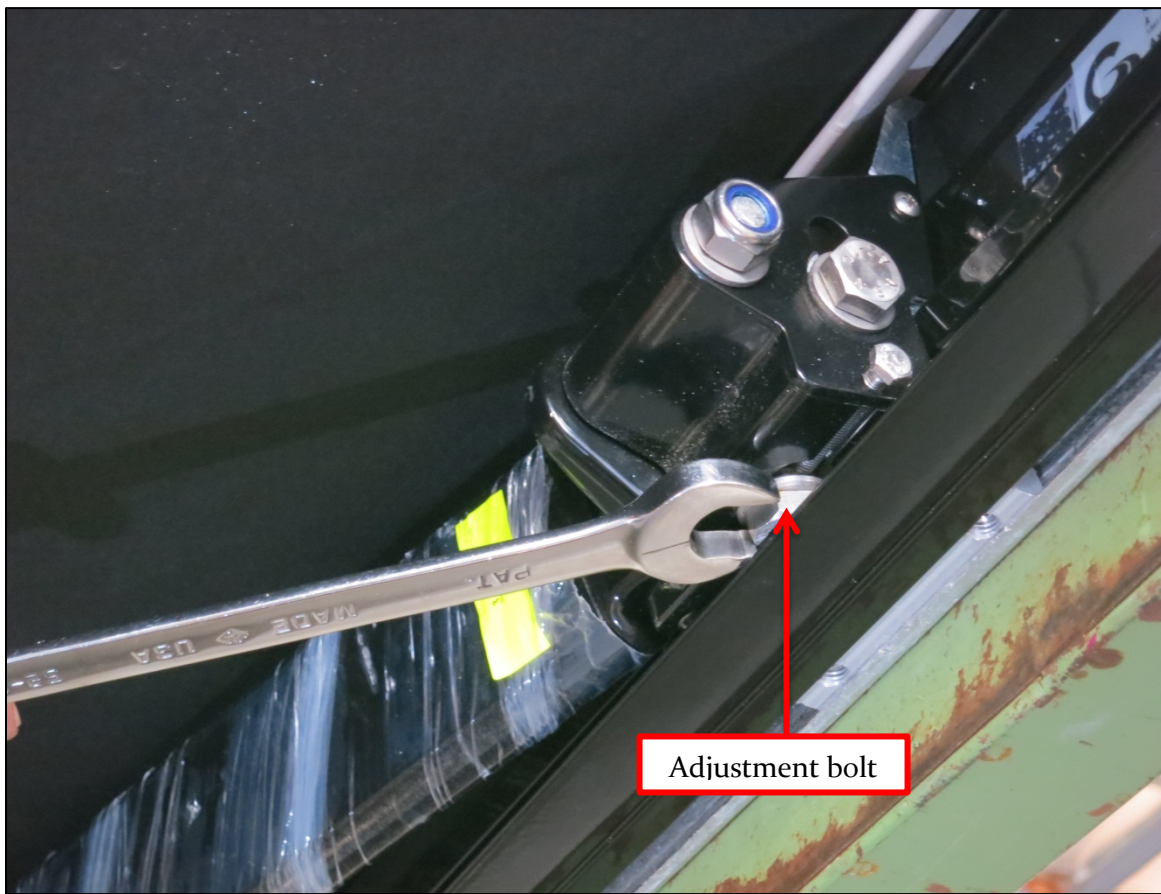

(Figure 18)



## **TESTING THE ANEMOMETER (Wind Sensor)**

Partially extend the awning.

Manually activate the anemometer by blowing on the cups or by spinning them or press the **UP** button on the anemometer. **NOTE: If the up button is used the anemometer will be disabled for 5 minutes.**

At this point the awning should retract; if not, check motor connection for correct polarity.

**NOTE: The Anemometer will send a retract signal to 2 of the awnings installed on the RV.** The power system of the vehicle must be able to withstand the resulting surge of current. The surge will be the greatest when the awnings are fully extended. When testing the system verify all of the awnings will close when fully extended. If there are more than two awnings a second anemometer must be used.

If the system does not operate correctly under these conditions:

- A. Provide sufficient power from your panel.
- B. Replace the anemometer in the electronics system with a Motion Sensor.

## **ADJUSTING THE LEAD RAIL**

The lead rail on the awning has been preset from the factory at +/- 3 degrees. This allows the lead rail to rest firmly into the cassette and also creates a weather resistant seal for travel. To increase or decrease the pitch angle insert a 5mm Allen wrench into the top pitch-angle screw. Turn clockwise to increase the pitch and turn counterclockwise to decrease the pitch. (Figure 19)

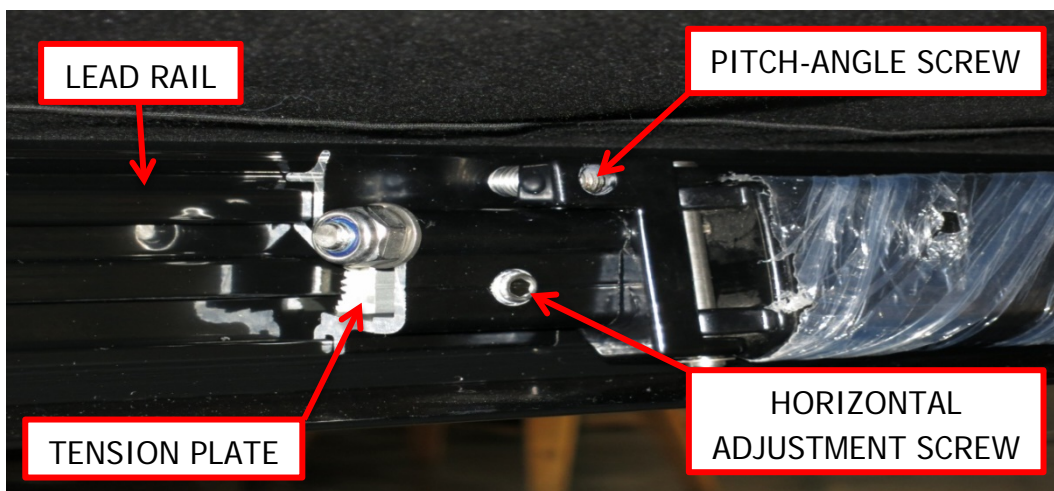

(Figure 19)

# TROUBLESHOOTING GUIDE

**Girard Systems recommends that all adjustments be made by authorized service centers. The following guide is intended to help the user become familiar with the awning in case of emergency.**

**PROBLEM:**

The lead rail is binding on the side of the awning casing; i.e. the rail is offset from housing.

**SOLUTION:**

Open the awning about 3 feet. Loosen the set screw on each arm at the point of connection to the lead rail. Locate and remove the two fabric set screws that are on each end of the lead rail. The lead rail is now ready to be shifted. Close the awning until the lead rail is about 4" away from closing into the housing. Using a rubber mallet, tap the end of the lead rail to move it into the correct position. When proper alignment has been achieved tighten the lead rail set screws (Figure 20), and then replace the fabric screws. (Figure 21)



(FIGURE 20)



(FIGURE 21)

**PROBLEM:**

The motor side of the awning closes when the awning is retracted but the opposite end does not.

**SOLUTION:**

Refer to "Adjusting the Lead Rail" on page 23. If this does not solve the issue please call the Girard Systems service line TOLL FREE on (800) 382-8442.

**PROBLEM:**

Motor will not operate.



SOLUTION:

Check that all of the GFI switches in the vehicle are turned on. If the vehicle has an Awnings Power Main Switch, locate that switch and make sure it is in the ON position. The motor supplied in the G-2000 and G-1500 Awnings are designed for intermittent use and may cut out temporarily if it has overheated. When this occurs sufficient time must be allowed for the motor to cool so that the internal circuit breaker can reset. This may take up to an hour depending on the outside temperature. The manual crank can be used during this period.

If this does not solve the issue please call the Girard Systems service line TOLL FREE on (800) 382-8442.

PROBLEM:

The motor will operate for 10-12" and then stop.

SOLUTION:

The motor may not be receiving enough amps (inverter power is low) to operate correctly. Check to ensure that there is a minimum of 10 amps available, if not turn on the generator or switch to a shore connection. If this does not solve the issue please call the Girard Systems service line TOLL FREE on (800) 382-8442.

PROBLEM:

The fabric is loose when the awning is fully extended; i.e. the roller keeps turning after the awning arms have locked open.

SOLUTION:

The motors OUT limits must be reset to factory standards. Please refer to the "Adjusting the Motors Limit Switches" section on pages 26-27

PROBLEM:

The motor stops before the lead rail has closed completely into the awning cassette on either or both sides. There is no apparent binding of the awning components.

SOLUTION:

The G-2000 and G-1500 Awnings are equipped with a manual override motor which has manual limit settings. The IN limit may need to be adjusted to allow the box to be closed tighter. "Adjusting the Motors Limit Switches" section on pages 26-27.

PROBLEM:

As the awning is closing, the elbow of one or more of the arms is hanging down preventing the case from closing.

SOLUTION:

Please refer to the "Adjusting pitch and Arm (Elbow) Height on page 28-29.

## **COMMON REPAIR PROCEDURES**

### **MOTOR REPLACEMENT**

NOTE: Replacement procedures vary due to motor styles, placement, factory installation methods, and preferences of different vehicle manufacturers. These variations primarily effect how the motors are accessed; replacement operations are generally the same for any situation.

#### **A. REMOVING THE OLD MOTOR**

1. Fully extend the awning with the manual crank until the fabric is hanging directly from the bottom of the roller tube.
2. Remove the right-hand awning end plate by removing the three screws that secure it to the awning case. (Figure 22)

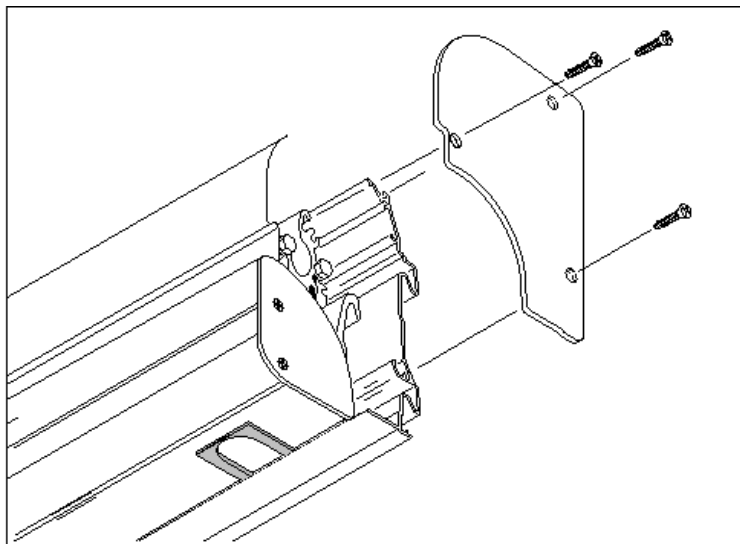

(Figure 22)

3. Remove both of the motor bolts that fasten the motor to the end bracket. Mark the slots from which the bolts were removed.
4. Loosen the small bolt that secures the roller tube support bracket to the main housing. **DO NOT OVER-LOOSEN OR ATTEMPT TO REMOVE THIS BOLT.** Slide motor support out of main housing.
5. From inside of the vehicle locate the motor cord. Find the termination point of the cord. (This may be located in a junction box used for the awnings, or an electrical junction box. These are typically located in an upper cabinet. The motor cord is white with four wires. Notate the points that each of the motor wires connect to. Disconnect all four motor cord wires.



6. Fasten a long “pigtail” extension to the motor cord (string, rope, a small wire, etc. can be used). This will assist in pulling through the new motor wire. Exit the vehicle and pull the motor cord completely through the wall.
7. Remove the screw that fastens the fabric to the roller tube. This screw is located along the edge of the roller tube near the head of the motor.
8. Carefully pull the old motor out of the awning roller tube. (Figure 23) Pull motor cord out of the hole in the back of the awning leaving the pigtail for the new installation.

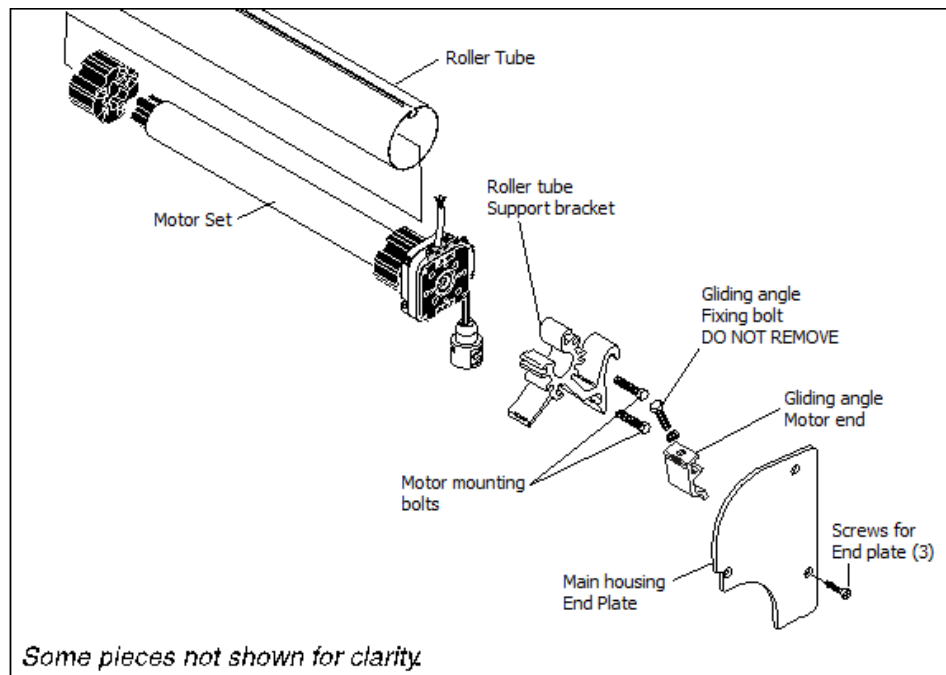

(Figure 23)

## B. INSTALLING THE NEW MOTOR

1. With the new motor in hand, align the notch in the black drive-disk (at the far end of the motor) with the indentation in the awning roller tube. Slide the motor all the way in. Turn the motor until its notch also lines up with the roller tube indentation.
2. Feed motor cord completely through strain relief in the back of the awning casing. Fasten the motor cord to the “pigtail” that was previously left.
3. Make sure the awning roller tube is still seated in the roller tube support bracket at the opposite end of the awning.
4. Rotate the motor and roller tube assembly until the motor-limit switches are accessible. They will be at an approximate 6 o'clock position; the manual overdrive mechanism must have proper downward clearance.

5. Slide the roller tube bracket back into the cassette and then tighten the small bolt that secures the two brackets together.
6. Adjust the roller tube/ motor assembly until the threaded holes in the motor bracket line up with the 2 holes that were marked previously. **IMPORTANT NOTE: TAKE CARE WHEN ALIGNING THE MOTOR NOT TO DAMAGE THE MOTOR OR THE SURROUNDING PARTS.**
7. Replace the end cap.
8. From the interior of the vehicle pull the motor cord all the way into the unit.
9. Connect the new motor as shown in Figure 24, according to the type of motor.
10. Test for the proper function of the new motor by using the Remote Control or the wall switch. Manually crank the awning to the closed position to adjust the motor limits.
11. After the motor has been replaced, the motors' limit switches must be adjusted. Please refer to the "ADJUSTING MOTOR LIMIT SWITCHES" section of this manual.
12. Manually activate the anemometer by blowing on the cups or by spinning them. Awning must retract, if not check motor connections for proper polarity. If the electronics system is equipped with a Motion Sensor, while extended, push up on the lead rail about 12" and let it drop. Awning must retract.

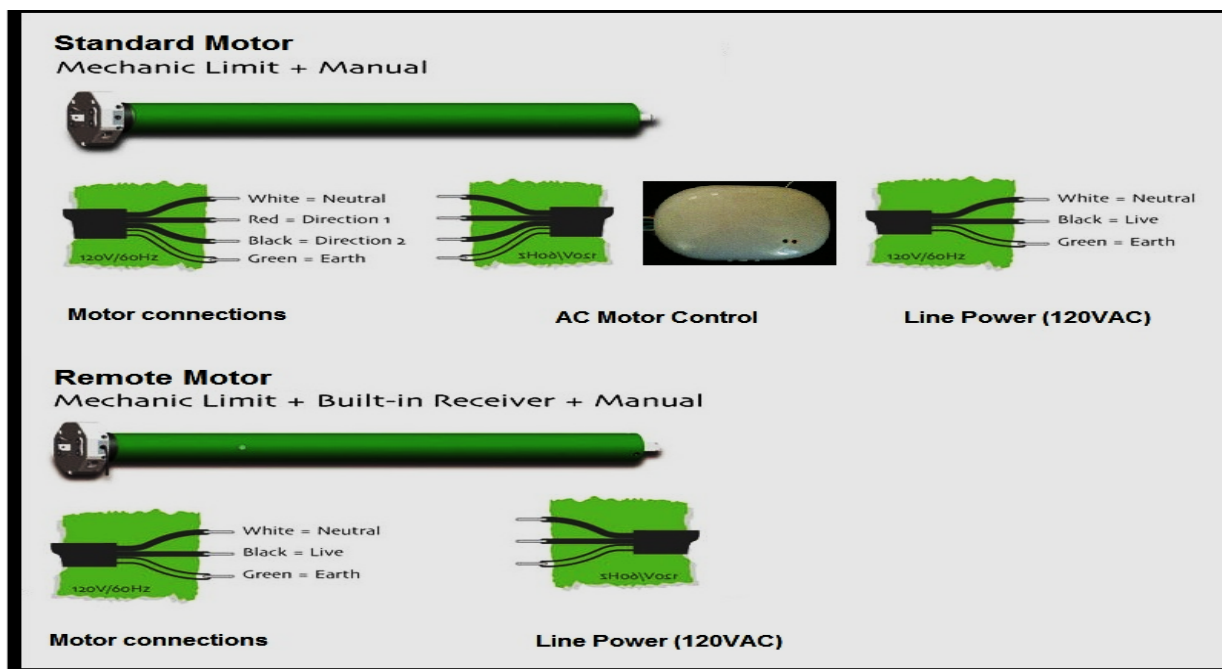

(Figure 24)





# **FABRIC REPLACEMENT**

**IMPORTANT NOTE: THESE PROCEDURES REQUIRE THE USE OF A MANUAL CRANK. IF NO MANUAL CRANK IS AVAILABLE THE MOTOR LIMIT SWITCHES MUST BE USED TO CREATE THE SETTINGS. PLEASE REFER TO THE “ADJUSTING MOTOR LIMIT SWITCHES”. USE THE MOTOR SPARINGLY TO PREVENT OVERHEATING.**

## **FABRIC REPLACEMENT PROCEDURE**

This procedure is recommended for all patio awnings that have been surface or recess mounted to the vehicles sidewall, as well as roofmount applications. In all cases the old fabric can be removed without having to remove the entire awning or the roller tube. All awning components will remain in position.

### **A. REMOVING THE OLD FABRIC**

1. Open the awning to full extension. Use the manual crank to continue rotating the roller tube until all of the fabric is unrolled and the C-shape channel of the roller tube is accessible. If no manual crank is available use the motor limit switches to adjust the OUT limit until the C-shaped channel is accessible
2. Remove the two fabric set screws. The 2 fabric set screws are located on the lead rail.
3. Remove the corresponding lead rail end cap and housing end plate.

Figure 25 and 26

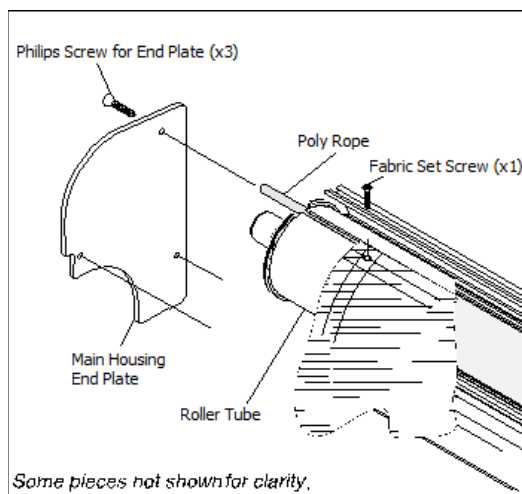

(Figure 25)

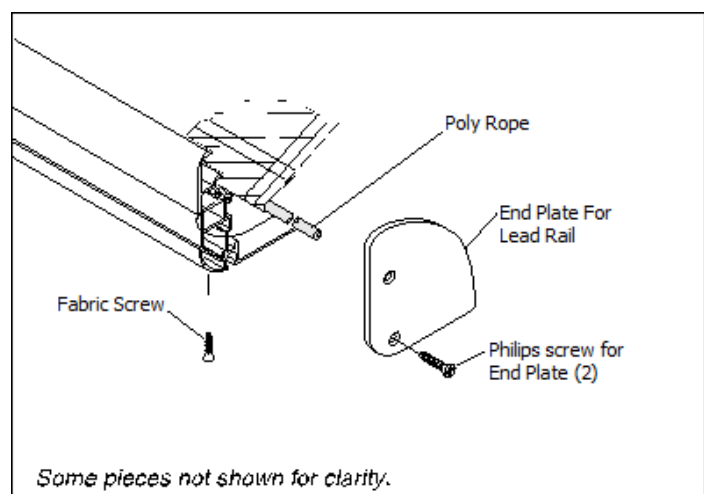

(Figure 26)



4. Carefully slide out the entire fabric from the left end of the roller tube and lead rail. Make sure the polyrope clears the support bracket.

**NOTE: FOR PERSONAL SAFETY, AND BEST RESULTS IT IS RECOMMENDED THAT FOUR TECHNICIANS PERFORM THIS TASK.**

#### B. INSTALLING THE NEW FABRIC

**IMPORTANT: REPLACEMENT FABRICS ARE ROLLED FOR SHIPMENT. THE SEAMS MUST FACE DOWNWARDS AS THE FABRIC IS INSTALLED. THERE IS A SMALL WHITE POLY (POLYESTER) ROPE INSERTED IN THE FABRIC THAT WILL SLIDE INTO THE ROLLER TUBE.**

1. Apply masking tape to the sharp edges of the lead rail's C-shaped fabric channel, and all sharp edges of the awning cassette and the roller tube support bracket. This will allow the fabric to enter the channel freely without snagging or tearing.
2. Insert the leading edges of the fabric into the C-shaped channel in the lead rail and roller tube on the side where the end caps have been removed. **This task is safely and most easily achieved with four people.** Carefully slide the new fabric into the lead rail and roller tube simultaneously. Two people can pull the fabric through the channels while two others support the excess fabric and feed the fabric into the lead rail and roller tube.
3. Center the fabric on the roller tube and then smooth all of the wrinkles out at the lead rail. Insert a self-tapping screw into the roller tube on the side opposite the motor location. The fabric will center itself on the lead rail. (Figure 16)
4. Using the manual crank, slowly begin rolling the fabric onto the roller tube. Roll the fabric from the bottom of the roller tube.
5. Start retracting the awning using the remote control or the wall switch. Using two people carefully stretch the fabric from end to end during the first couple of revolutions of the roller tube. This will ensure that the fabric is rolling onto the tube straight. Continue to slowly roll the fabric onto the tube until the fabric is taut against the lead rail. Continue to roll the fabric onto the tube. Make sure the fabric rolls straight and the awning closes completely.
6. Open the awning about 18" and replace both fabric set screws on the lead rail.

**NOTE: These screws should be located no more than  $\frac{3}{4}$ " from the edge of the fabric. If necessary, re-drill the fabric set screw holes using a  $\frac{1}{8}$ " drill bit to maintain this distance.**

7. Reinstall both the lead rail and main housing end caps.



8. After the fabric replacement it may be necessary to make minor adjustments to the motor limit switches. The awning motor needs to stop the exact moment when the awning cassette is fully closed. Likewise, it is important that the awning motor stops just before the arms become fully locked in the extended position. (The fabric will be taut; the elbows slightly bent exposing about 1/8' of gap.) Please refer to the "ADJUSTING MOTOR LIMIT SWITCHES" section of this manual.

**IMPORTANT NOTE: THE HIGH-TORQUE MOTOR SUPPLIED WITH THE G-2000 Awning IS DESIGNED TO RUN FOR ONLY 2 MINUTES PER HOUR. THE MOTOR HAS A BUILT-IN CIRCUIT BREAKER WHICH IS DESIGNED TO ACTIVATE IF THE MOTOR OVERHEATS. COOL DOWN TIME CAN BE UP TO AN HOUR DEPENDING ON THE OUTSIDE TEMPERATURE.**

## **ARM REPLACEMENT**

Follow this procedure when a damaged, spring loaded arm needs to be replaced. There are no repairable parts inside of the arm. If the elbow joint has broken the entire arm must be replaced.

### **TOOLS REQUIRED:**

- 19mm (3/4") open-end wrench
- 17mm (11/16") open-end wrench
- 5mm (3/16") Allen wrench



### **WARNING**

- Follow installation instructions carefully.
- Awning arms are packaged under heavy spring tension.
- To avoid serious personal injury do not remove protective wrapping until directed to do so.



1. Support the lead rail and carefully open the awning a few feet. If the elbow is open tie a large rag around it to protect the fabric from the elbow.
2. Cut the stainless steel cable at the elbow to release the spring tension, and then proceed with arm removal. If leaving the arm under tension, remove the 17mm nut at the lead rail connection, fold and tape the arm very carefully, then proceed with arm removal.
3. On the lead rail side of the arm remove the 17mm nut and washer, set them aside to later connect the new arm.
4. At the shoulder assembly of the arm, in the cassette, remove both 19mm lock nuts and washers, or the bolt and nut.
5. Remove the forward most bolt from the arm and shoulder connection. Use this bolt for the new arm installation if new hardware is not provided. Hold the bottom pitch adjustment block to keep it from falling. When removing the arm from the shoulder pay special attention to the parts located in the shoulder washer-square tube pitch adjustment screw and block.
6. Carefully slide the arm and remaining bolt away from the shoulder.
7. **Do not unband new arm until it has been fastened to the shoulder inside of the cassette.**
8. If the arm being replaced has a fixed bolt: Insert the arm into the shoulder, ensure that the fixed bolt on the arm goes through the pitch adjustment assembly, the spacer bushing, and the washer. (These are the components inside of the shoulder) Insert the previously removed bolt and nut. If the arm being replaced does not have a fixed bolt: Use the bolt supplied with the arm, slide through the spacer bushing for shoulder support, the pitch-adjustment assembly, and the arm connection plate. Insert the previously removed bolt and nut.
9. With the awning open about 18"; unband the high tension arm very carefully. Slowly guide it into position on the lead rail and fasten with the 17mm bolt and nut.
10. Attach the front of the arm to its connection point at the lead rail by replacing the pivot pin from the top and securing it with the retaining ring (e-clip) (Figure 28) and then slide into the lead rail connection and replace the nut and washer. At the shoulder assembly of the arm, tighten both lock nuts until they are one turn from being tight. Adjust the arms' pitch angle to match the others by rotating the head of the pitch-adjustment screw as follows; rotate in a clockwise direction to lower the arm, or rotate counterclockwise to raise it. Fully tighten

both lock nuts on the shoulder assembly. Please refer to the "ADJUSTING THE PITCH ANGLE" section of this manual.

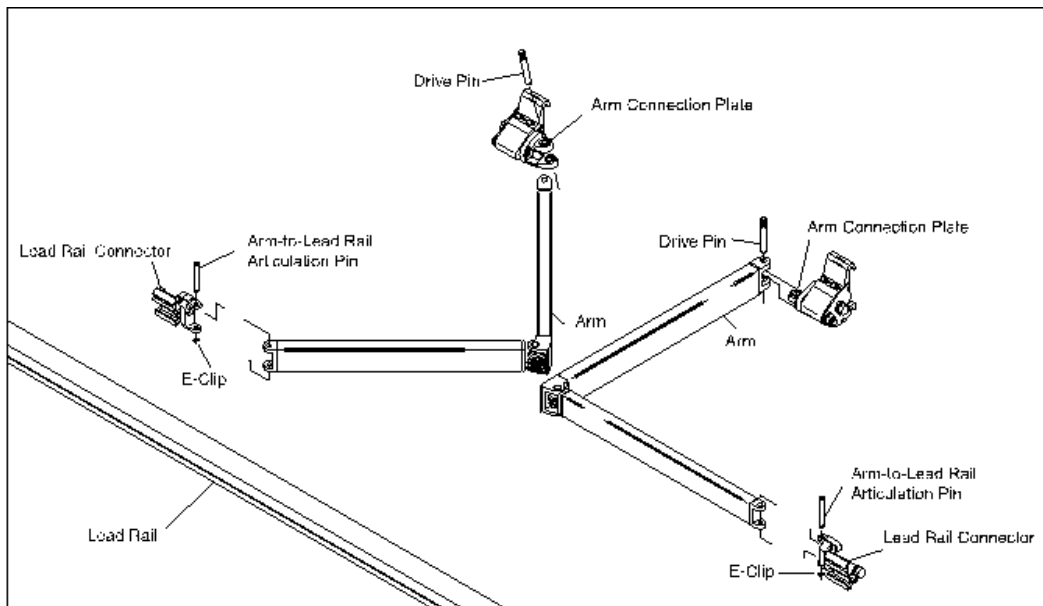

(Figure 28)

**SHOULDER ASSEMBLY**

ARM LOCKING BOLT



ARM ELEVATION  
SCREW

PIVOT  
BOLT

SHOULDER LOCKING SCREWS



SPACER  
BUSHING

PITCH ADJ.  
BOLT



## **CARE AND MAINTENANCE GUIDE**

### **AWNING FABRICS**

For all cleaning, stain removal, care and maintenance of Acrylic and Polyester fabrics the recommendations are the same.

#### **Fabric Care Guidelines**

1. Brush off surface dirt with a clean soft bristle brush.
2. Hose down the fabric with clean water.
3. Use only natural soap or dishwashing liquid.
4. Prepare soap mixture in a clean bucket.
5. Dunk a clean, soft bristle brush into the mixture.
6. Use sweeping motions to clean the awning.
7. Allow soap to soak in and capture dirt.
8. Rinse thoroughly to remove all residues.

**AIR DRY ONLY! Pressing, steaming, or machine drying will shrink awning fabric.**

## **STAIN SOLUTIONS**

| <b><u>STAIN</u></b>    | <b><u>RECOMMENDED CLEANING SOLUTIONS</u></b>                    |
|------------------------|---|
| BEER                   | Dishwashing liquid (2 oz.)/1 gallon water/white vinegar (3 oz.) |
| BERRY                  | Dishwashing liquid (2 oz.) /1 gallon water / ammonia (4-8 oz.)  |
| BIRD DROPPINGS         | Dishwashing liquid (2 oz.)/1 gallon water.                      |
| BLOOD (DRIED)          | Dishwashing liquid (2 oz.) / 1 gallon water / ammonia (4-8 oz.) |
| BUTTER                 | volatile solvent (acetone) 100%                                 |
| CHARCOAL, PENCIL MARKS | vacuum, then dishwashing liquid (2 oz.) / 1 gallon water        |
| CATSUP OR MUSTARD      | Dawn® dishwashing liquid (2 oz.) / 1 gallon water               |
| CHEWING GUM            | volatile solvent (acetone) 100%                                 |
| CHOCOLATE              | Dishwashing liquid (2 oz.) / 1 gallon water / ammonia (4 oz.)   |
| COFFEE                 | Dishwashing liquid / water, white vinegar, acetone              |
| COLA                   | Dishwashing liquid (2 oz.) / 1 gallon water                     |



|                                   |  |
|-----------------------------------|--|
| CRAYON                            | Paint remover (100%), oil or grease remover (mix as directed)                                      |
| EGG (RAW)                         | Dishwashing liquid (2 oz.) / 1 gallon water  |
| GRAPE JUICE                       | Dishwashing liquid (2 oz.) / 1 gallon water  |
| GRAVY                             | Dishwashing liquid (2 oz.) / 1 gallon water  |
| GREASE (CAR)                      | volatile solvent (acetone) 100%  |
| INK (PERMANENT, INDIA, BALLPOINT) | Paint remover (100%), volatile solvent (acetone) 100%, soap and water                              |
| IRON RUST                         | Oxalic or Citric acid (2oz.) / 1 gallon water  |
| LIPSTICK                          | Paint remover, oil or grease remover (mix as directed)   |
| MASCARA                           | Paint remover (100%), volatile solvent (acetone-100%), dishwashing liquid (2 oz.) / 1 gallon water |
| MILDEW                            | Bleach (1/2 cup) /dishwashing liquid (2 oz.) / 1 gallon water                                      |
| MILK                              | Dishwashing liquid (2 oz.) / 1 gallon water  |
| NAIL POLISH                       | volatile solvent (acetone) 100%  |
| OIL                               | volatile solvent (acetone) 100%  |
| ORANGE DRINK                      | Dishwashing liquid (2 oz.) / 1 gallon water  |
| PAINT (LATEX) WET                 | Dishwashing liquid (2 oz.) / 1 gallon water  |
| PAINT (LATEX) DRIED               | Paint remover (100%), oil or grease remover (mix as directed)                                      |
| PAINT (OIL OR LACQUER)            | Paint remover (100%), oil or grease remover (mix as directed)                                      |
| SHOE POLISH (LIQUID)              | volatile solvent (acetone) 100%  |
| SHOE POLISH (WAX)                 | apply heated iron over towel, volatile solvent (acetone) 100%                                      |
| SUNTAN LOTION                     | Pine oil detergent / water (mix as directed)   |
| TEA                               | Dishwashing liquid (2 oz.) / 1 gallon water  |
| TOMATO JUICE                      | Dishwashing liquid (2 oz.) / 1 gallon water  |
| TREE SAP                          | Turpentine (100%), dishwashing liquid (2 oz.) / 1 gallon water                                     |
| URINE                             | Dishwashing liquid (2 oz.)/1 gallon water/white vinegar (3 oz.)                                    |
| VOMIT                             | Dishwashing liquid (2 oz.)/1 gallon water/white vinegar (3 oz.)                                    |
| FOOD COLOR                        | Dishwashing liquid (2 oz.)/1 gallon water/white vinegar (3 oz.)                                    |
| WAX (CANDLE)                      | apply heated iron over towel, volatile solvent (acetone) 100%                                      |
| WINE                              | Dishwashing liquid (2 oz.) / 1 gallon water / ammonia (4-8 oz.) / white vinegar (3 oz.)            |



# TECHNICAL SPECIFICATIONS

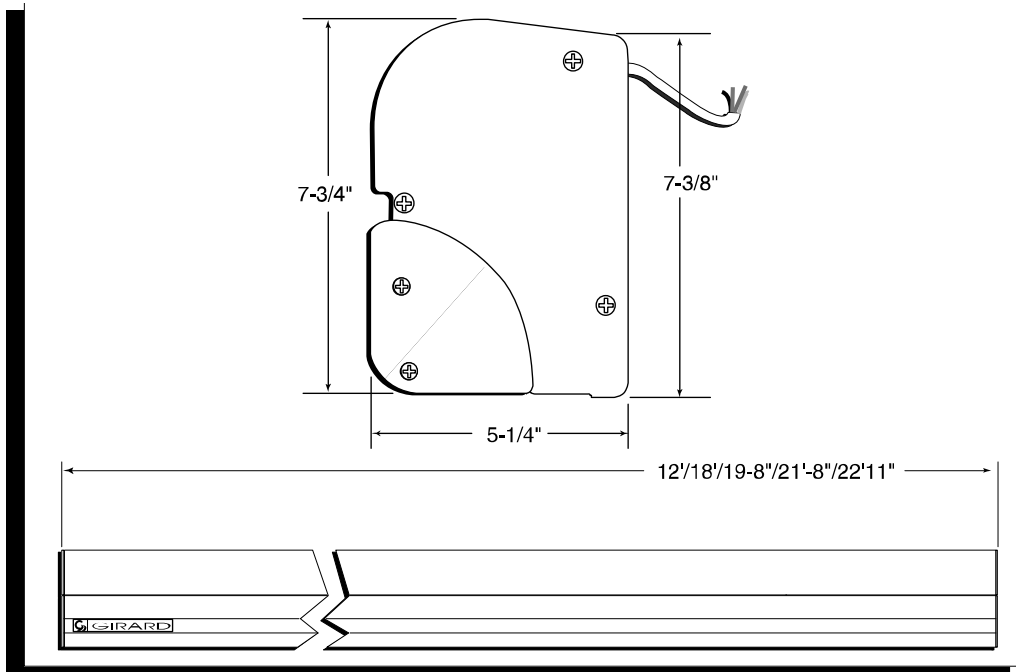

G-2000 Awning Case Dimensions (External)

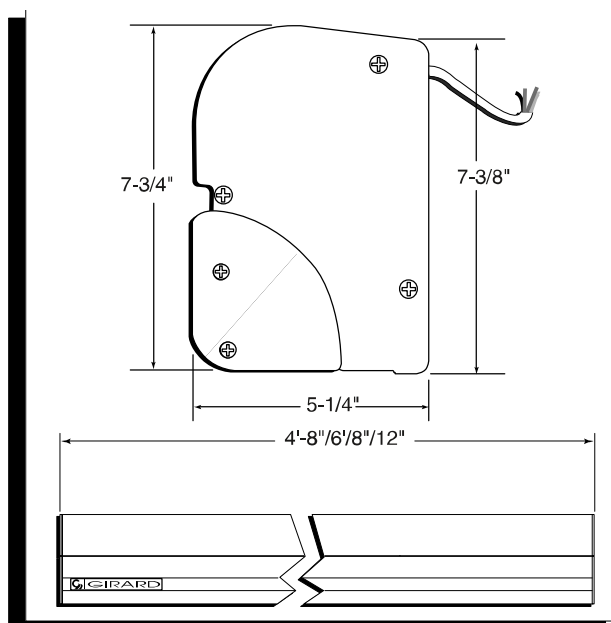

G-1500 Awning Case Dimensions (External)



| AWNING     | G-1500             |       | G-2000               |        |
|------------|--------------------|-------|----------------------|--------|
| WIEGHT     | 4'8"               | 40LBS | 12'0"                | 116LBS |
|            | 6'0"               | 55LBS | 18'0"                | 172LBS |
|            | 8'0"               | 70LBS | 19'8"                | 188LBS |
|            | 10'0"              | 85LBS | 21'8"                | 208LBS |
|            | 12'0"              | 95LBS | 22'11"               | 220LBS |
| MOTOR      | TUBULAR            |       | TUBULAR WITH M/O     |        |
| VOLTAGE    | 12v DC             |       | 120v AC 60Hz         |        |
| SPEED      | 7 RPM 4min max run |       | 13 RPM 4min max run  |        |
| POWER      | 7 Amps – 84 Watts  |       | 2.2 Amps – 235 Watts |        |
| TORQUE     | 35 NM              |       | 50 NM                |        |
| PROTECTION | FUSE               |       | THERMAL CUT OUT      |        |

|                           |                   |
|---------------------------|-------------------|
| BRACKETS OUTER            | 7 5/16" X 19 1/2" |
| BRACKETS CENTER UP TO 18' | 7 5/16" X 4"      |
| BRACKETS CENTER OVER 18'  | 7 5/16" X 11 1/2" |

|                             |
|-----------------------------|
| ROLLER TUBE DIAMETER = 3"   |
| FABRIC = 100% WOVEN ACRYLIC |

| POWER CORD and CABLE LENGTHS |                       |
|------------------------------|-----------------------|
| AWNING MOTOR                 | 6' 16Amp POWER CORD   |
| ANEMOMETER                   | 6' 16Amp POWER CORD   |
| WALL MOUNTED SWITCHES        | 10' Low voltage cable |

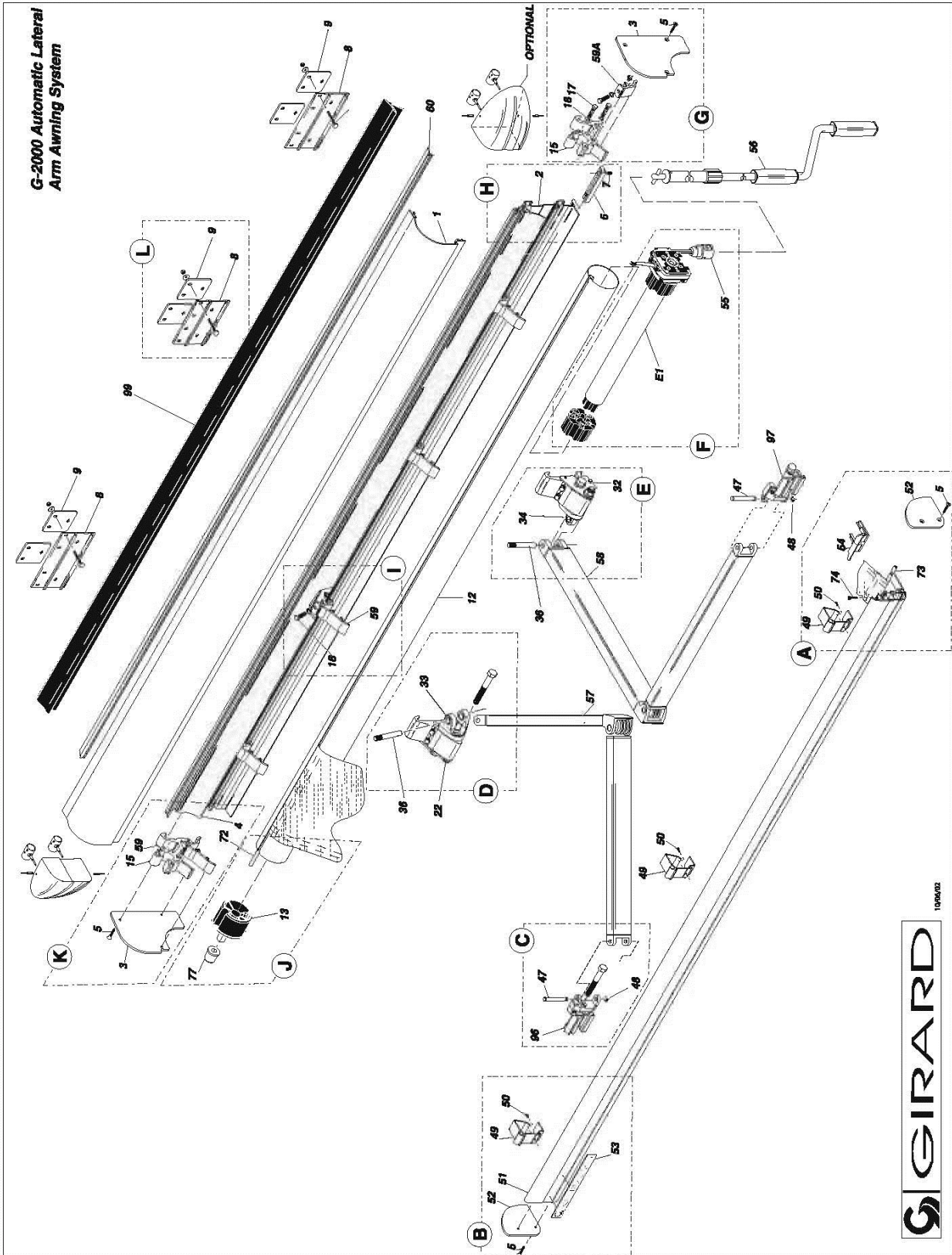



**G-1500 Automatic Lateral  
Arm Door and Window  
Awning System**

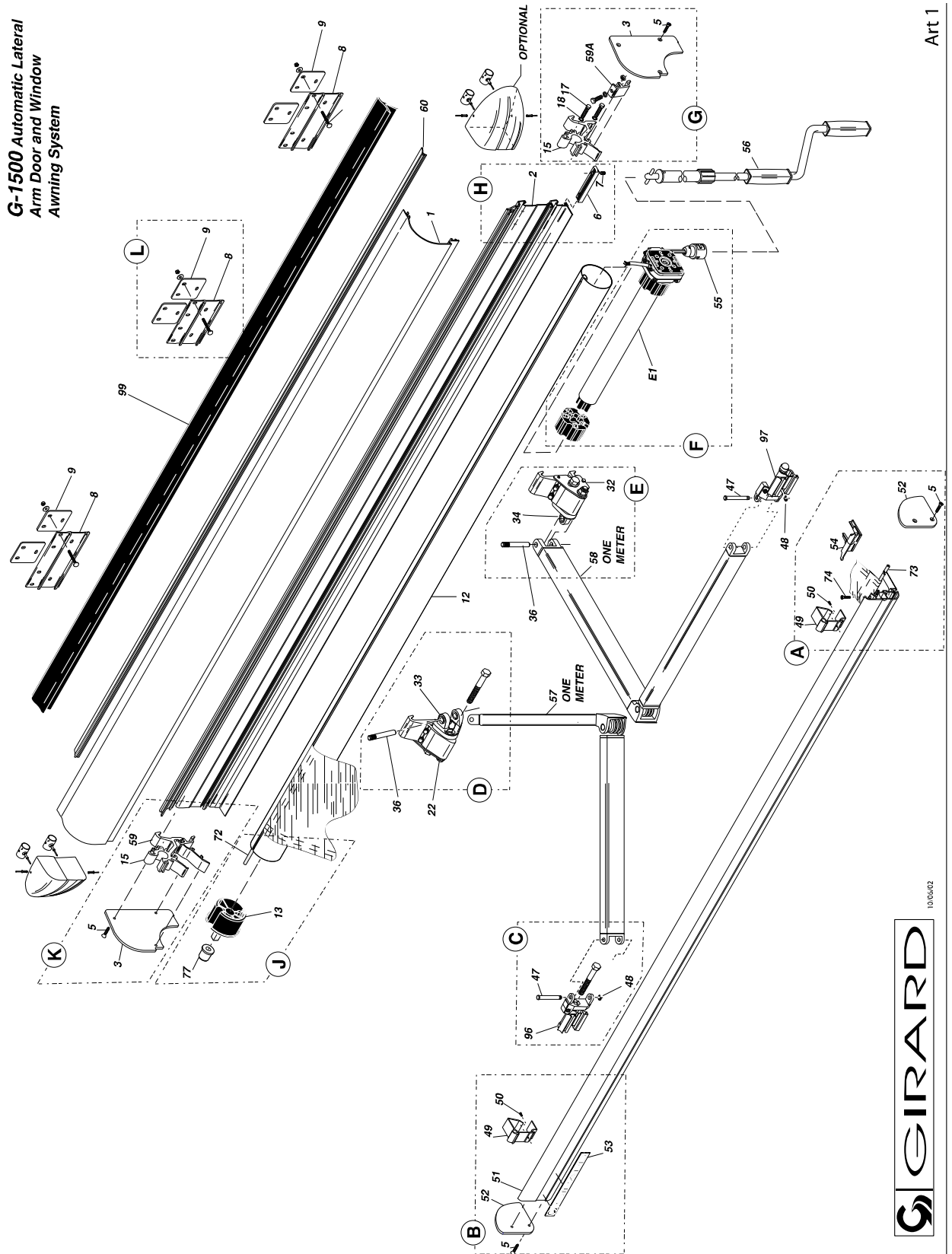

Art 1



10/05/02

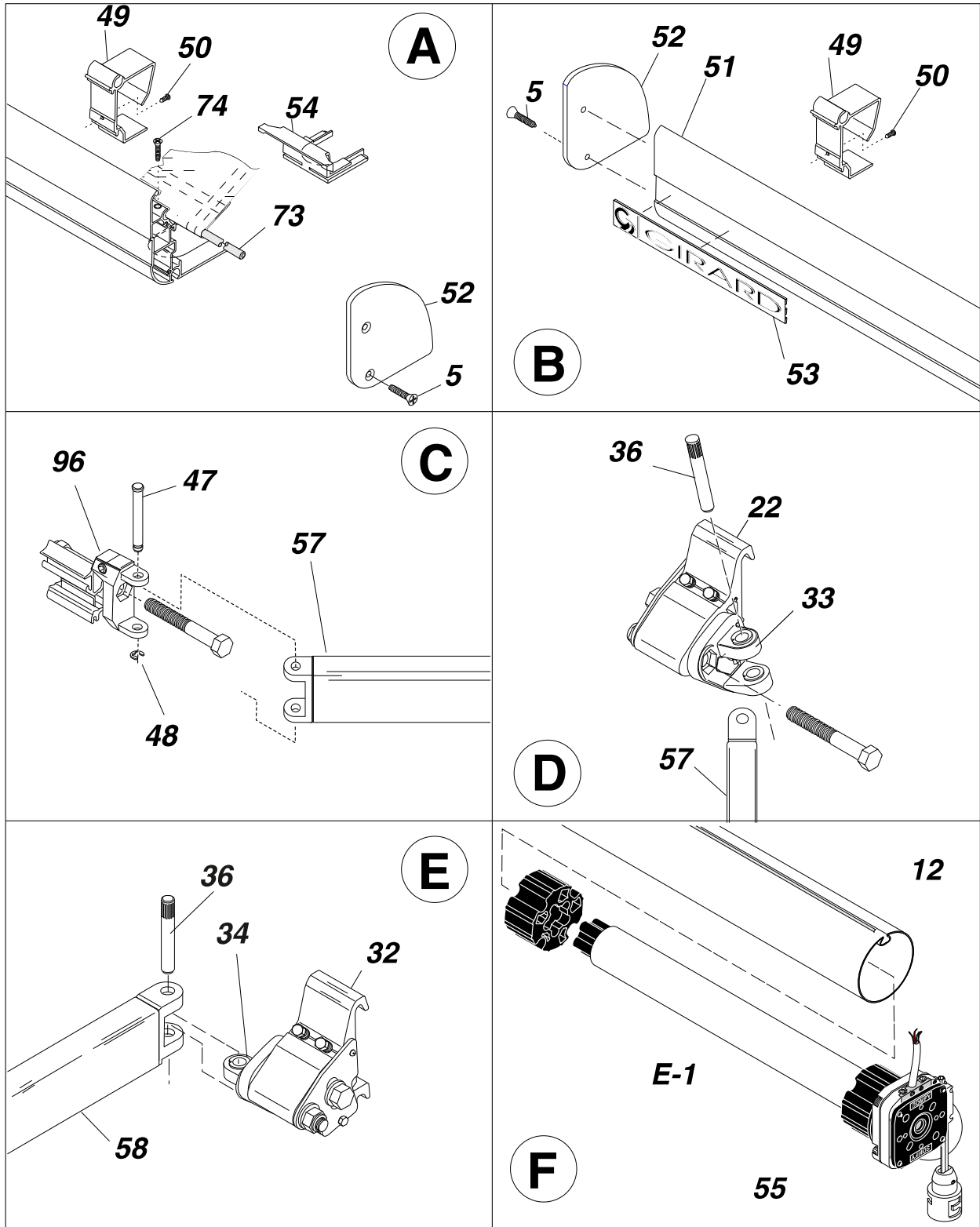

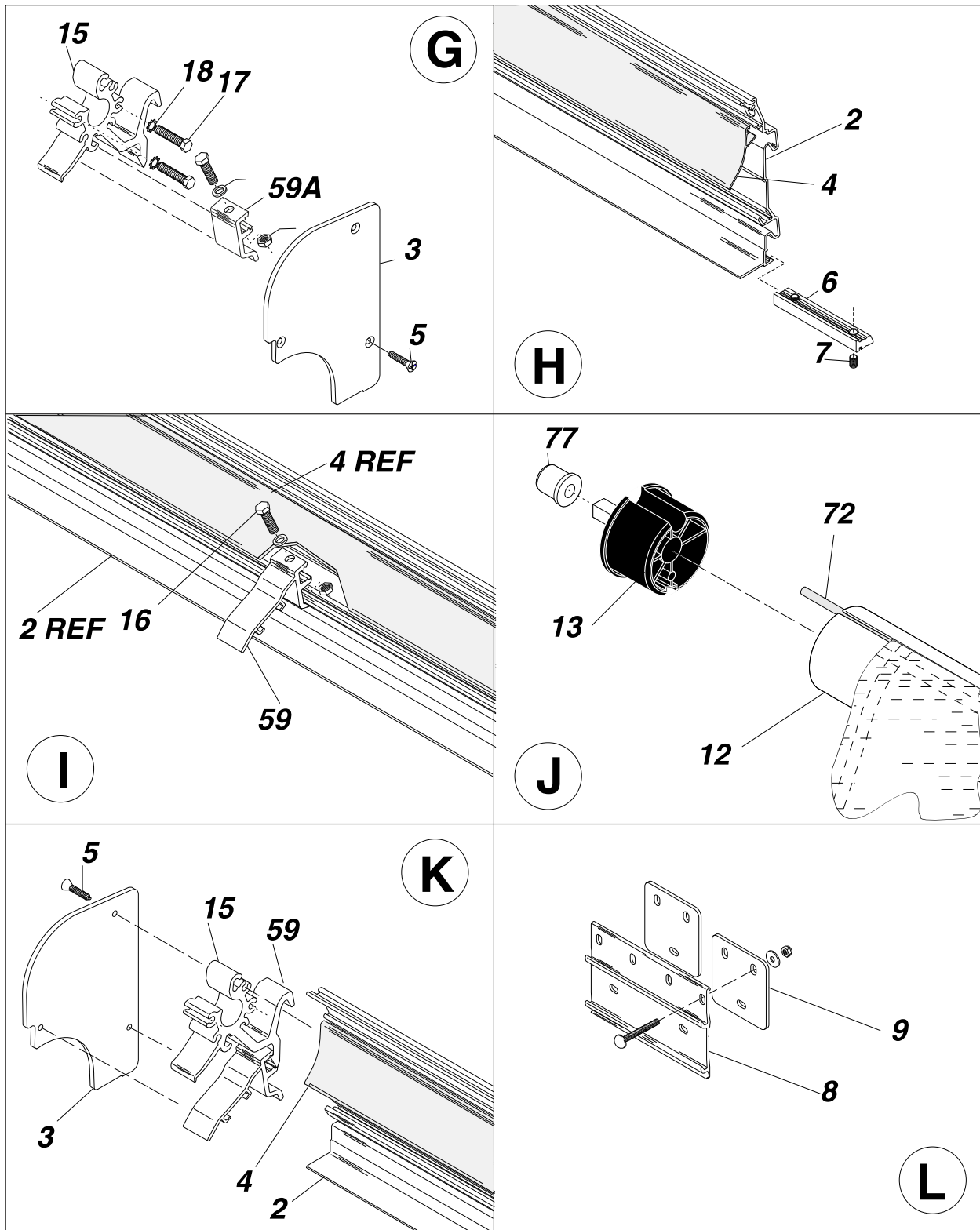



## **COMPONENT IDENTIFICATION**

| <b>ITEM #</b> | <b>DESCRIPTION</b>                | <b>PART No.</b> |
|---------------|-----------------------------------|-----------------|
| <b>01</b>     | Main Housing Cover - 12' WHT      | 1500031-01      |
|               | Main Housing Cover - 12' BLK      | 1500031-012     |
| <b>01</b>     | Main Housing Cover - 14' WHT      | 1500032-01      |
|               | Main Housing Cover - 14' BLK      | 1500032-012     |
| <b>01</b>     | Main Housing Cover - 16' WHT      | 1500033-01      |
|               | Main Housing Cover - 16' BLK      | 1500033-012     |
| <b>01</b>     | Main Housing Cover - 18' WHT      | 1500034-01      |
|               | Main Housing Cover - 18' BLK      | 1500034-012     |
| <b>01</b>     | Main Housing Cover - 19' 8" WHT   | 1500035-01      |
|               | Main Housing Cover - 19' 8" BLK   | 1500035-012     |
| <b>01</b>     | Main Housing Cover - 21' 8" WHT   | 1500040-01      |
|               | Main Housing Cover - 21' 8" BLK   | 1500040-012     |
| <b>01</b>     | Main Housing Cover - 22'11" WHT   | 1500041-01      |
|               | Main Housing Cover - 22'11" BLK   | 1500041-012     |
|               | Main Housing Gutter 18' Plastic   | 1500549-60      |
| <b>02</b>     | Back Housing - 12' WHT            | 1500076-02      |
|               | Back Housing - 12' BLK            | 1500076-022     |
| <b>02</b>     | Back Housing - 14' WHT            | 1500077-02      |
|               | Back Housing - 14' BLK            | 1500077-022     |
| <b>02</b>     | Back Housing - 16' WHT            | 1500078-02      |
|               | Back Housing - 16' BLK            | 1500078-022     |
| <b>02</b>     | Back Housing - 18' WHT            | 1500079-02      |
|               | Back Housing - 18' BLK            | 1500079-022     |
| <b>02</b>     | Back Housing - 19'8" WHT          | 1500080-02      |
|               | Back Housing - 19'8" BLK          | 1500080-022     |
| <b>02</b>     | Back Housing - 21' 8" WHT         | 1500085-02      |
|               | Back Housing - 21' 8" BLK         | 1500085-022     |
| <b>02</b>     | Back Housing - 22'11" WHT         | 1500084-02      |
|               | Back Housing - 22'11" BLK         | 1500084-022     |
| <b>03</b>     | Main Housing End Plate - L.H. WHT | 1500090-03      |
|               | Main Housing End Plate - L.H. BLK | 1500090-033     |
| <b>03</b>     | Main Housing End Plate - R.H. WHT | 1500091-03      |
|               | Main Housing End Plate - R.H. BLK | 1500091-033     |
| <b>04</b>     | Back Housing Gutter 18'           | 1500549-04      |
| <b>04</b>     | Back Housing Gutter 19' 8"        | 1500096-04      |
| <b>04</b>     | Back Housing Gutter 21' 8"        | 1500097-04      |





|           |   |             |
|-----------|---|-------------|
| <b>05</b> | Screw For End Plates                                | 1500110-05  |
| <b>06</b> | Mounting Bracket Slide Lock                         | 1500111-06  |
| <b>07</b> | Mounting Bracket Slide Lock Allen Screw             | 1500112-07  |
| <b>08</b> | Mounting Bracket Middle - 4"                        | 1500113-08  |
| <b>08</b> | Mounting Bracket End - 19"                          | 1500114-08  |
| <b>08</b> | Mounting Bracket End - 11"                          | 1500115-08  |
| <b>08</b> | Mounting Bracket End - 39"                          | 1500116-08  |
| <b>09</b> | Mounting Bracket Backing Plate                      | 1500117-09  |
| <b>10</b> | Backing Plate Cover                                 | 1500117-10  |
| <b>12</b> | Roller Tube - 14'                                   | 1500126-14  |
| <b>12</b> | Roller Tube - 16'                                   | 1500126-16  |
| <b>12</b> | Roller Tube - 18'                                   | 1500126-18  |
| <b>12</b> | Roller Tube - 20'                                   | 1500126-20  |
| <b>12</b> | Roller Tube - 23'                                   | 1500126-23  |
| <b>13</b> | Roller Tube Gundgeon 78mm - All in One              | 1500143-13  |
| <b>15</b> | Roller Tube Support Bkt. WHT Including Bolt & Screw | 1500145-15  |
|           | Roller Tube Support Bkt. BLK Including Bolt & Screw | 1500145-154 |
| <b>17</b> | Bolt for Motor Mount                                | 155008-01   |
| <b>18</b> | Washer for Motor Mount                              | 155008-02   |
| <b>22</b> | Shoulder Support L.H. – Complete WHT                | 1500155-22  |
|           | Shoulder Support L.H. – Complete BLK                | 1500155-223 |
|           | Pitch Adjust Assembly                               | 1500160-27  |
| <b>32</b> | Shoulder Support R.H. – Complete WHT                | 1500164-32  |
|           | Shoulder Support R.H. – Complete BLK                | 1500164-323 |
|           | 70 mm Bolt for Shoulder                             | 1500168-37  |
| <b>33</b> | Arm Connection Plate Assy LH (casting, pin, bolt)   | 1500165-LH  |
| <b>34</b> | Arm Connection Plate Assy RH (casting, pin, bolt)   | 1500166-RH  |
| <b>36</b> | Pin for Arm Connection Plate                        | 1500168-36  |
| <b>47</b> | Arm to Lead Articulation Connector Pin              | 1500179-47  |
| <b>48</b> | E Clip for Arm to Lead Rail Articulation Pin        | 1500180-48  |
| <b>49</b> | Guide For Lead Rail WHT                             | 1500181-49  |
|           | Guide For Lead Rail BLK                             | 1500181-493 |
| <b>50</b> | Screw For Lead Rail Guide                           | 1550602     |
| <b>51</b> | Lead Rail - 12' WHT                                 | 1500225-51  |
|           | Lead Rail - 12' BLK                                 | 1500225-512 |
| <b>51</b> | Lead Rail - 14' WHT                                 | 1500226-51  |
|           | Lead Rail - 14' BLK                                 | 1500226-512 |
| <b>51</b> | Lead Rail - 16' WHT                                 | 1500227-51  |
|           | Lead Rail - 16' BLK                                 | 1500227-512 |
| <b>51</b> | Lead Rail - 18' WHT                                 | 1500228-51  |



|           |  |               |
|-----------|--|---------------|
|           | Lead Rail - 18' BLK                              | 1500228-512   |
| <b>51</b> | Lead Rail - 19' 8" WHT                           | 1500229-51    |
|           | Lead Rail - 19' 8" BLK                           | 1500229-512   |
| <b>51</b> | Lead Rail - 21' 8" WHT                           | 1500233-51    |
|           | Lead Rail - 21' 8" BLK                           | 1500233-512   |
| <b>51</b> | Lead Rail - 22'11" WHT                           | 1500235-51    |
|           | Lead Rail - 22'11" BLK                           | 1500235-512   |
| <b>52</b> | End Plate for Lead Rail - L.H. (Metal) WHT       | 1500252-52    |
|           | End Plate for Lead Rail - L.H. (Metal) BLK       | 1500252-523   |
| <b>52</b> | End Plate for Lead Rail – R.H. (Metal) WHT       | 1500253-52    |
|           | End Plate for Lead Rail – R.H. (Metal) BLK       | 1500253-523   |
| <b>52</b> | End Plate for Lead Rail - L.H. (Plastic) WHT     | 1500252-5201  |
|           | End Plate for Lead Rail - L.H. (Plastic) BLK     | 1500252-B5201 |
| <b>52</b> | End Plate for Lead Rail – R.H. (Plastic) WHT     | 1500523-5201  |
|           | End Plate for Lead Rail – R.H. (Plastic) BLK     | 1500523-B5201 |
| <b>53</b> | Girard Logo Plastic WHT                          | 3300504-001   |
|           | Girard Logo Plastic BLK                          | 3300504-002   |
| <b>54</b> | Plastic Cover for Motor Cut-out on Lead Rail WHT | 1500275-54    |
|           | Plastic Cover for Motor Cut-out on Lead Rail BLK | 1500275-543   |
| <b>55</b> | Gear Assembly (7/1)                              | 1500281-55    |
| <b>55</b> | Bell Housing for M.O.                            | 1500282-55    |
| <b>56</b> | Crank Handle - Non-Adjustable                    | 1500295-564   |
| <b>56</b> | Crank Handle - Adjustable                        | 1500295-56    |
| <b>57</b> | Arm - 3'3" Projection – L.H. WHT                 | 1500299-57K   |
|           | Arm - 3'3" Projection – L.H. BLK                 | 1500298-57K   |
| <b>57</b> | Arm - 5' 0" Projection - L.H. WHT                | 1500300-57K   |
|           | Arm - 5' 0" Projection - L.H. BLK                | 1500301-57K   |
| <b>57</b> | Arm - 6' 7" Projection - L.H. WHT                | 1500305-57K   |
|           | Arm - 6' 7" Projection - L.H. BLK                | 1500306-57K   |
| <b>57</b> | Arm - 8' 0" Projection - L.H. WHT                | 1500309-57K   |
|           | Arm - 8' 0" Projection - L.H. BLK                | 1500308-57K   |
| <b>57</b> | Arm - 9' 9" Projection - L.H. WHT                | 1500313-57K   |
|           | Arm - 9' 9" Projection - L.H. BLK                | 1500312-57K   |
| <b>58</b> | Arm - 3'3" Projection – R.H. WHT                 | 1500329-58K   |
|           | Arm - 3'3" Projection – R.H. BLK                 | 1500328-58K   |
| <b>58</b> | Arm - 5' 0" Projection - R.H. WHT                | 1500330-58K   |
|           | Arm - 5' 0" Projection - R.H. BLK                | 1500331-58K   |
| <b>58</b> | Arm - 6' 7" Projection - R.H. WHT                | 1500335-58K   |
|           | Arm - 6' 7" Projection - R.H. BLK                | 1500334-58K   |
| <b>58</b> | Arm - 8' 0" Projection - R.H. WHT                | 1500339-58K   |



|                          |  |              |
|--------------------------|--|--------------|
|                          | Arm - 8' 0" Projection - R.H. BLK              | 1500338-58K  |
| <b>58</b>                | Arm - 9' 9" Projection - R.H. WHT              | 1500343-58K  |
|                          | Arm - 9' 9" Projection - R.H. BLK              | 1500342-58K  |
| <b>59</b>                | Gliding Angle with Bolt and Nut WHT            | 1500350-59   |
|                          | Gliding Angle with Bolt and Nut BLK            | 1500350-593  |
| <b>60</b>                | Fabric Guide Rail Cover Housing - 21' 8"       | 1500361-60   |
| <b>60</b>                | Fabric Guide Rail Cover Housing 22'11"         | 1500362-60   |
| <b>72</b>                | Poly Rope 5.6 mm (@ Roller Tube)               | 1500372-00   |
| <b>73</b>                | Poly Rope 6.5 mm (@ Roller Tube)               | 1500373-00   |
|                          | Poly Rope - 3/16 BLK - for Recessed Awnings    | 1500374-00   |
| <b>74</b>                | Fabric Screw                                   | 1550602      |
| <b>77</b>                | Bushing for Gudgeon (slave side)               | 1500154-77   |
| <b>96</b>                | Lead Rail Connector - L.H. Complete WHT        | 1500175-96   |
|                          | Lead Rail Connector - L.H. Complete BLK        | 1500175-963  |
| <b>97</b>                | Lead Rail Connector - R.H. Complete WHT        | 1500178-97   |
|                          | Lead Rail Connector - R.H. Complete BLK        | 1500178-973  |
| <b>99</b>                | Rubber Seal for Flush Mount - Black (per foot) | 1500502-99   |
|                          | Roller Tube Coupler System Anodized            | 1500010-02   |
|                          | Coupler Set WHT Inter-Tube G2100               | 1500010-W31  |
|                          | Coupler Set BLK Inter-Tube G2100               | 1500010-B31  |
|                          | Tube Bush WHT Coupler G2100                    | 1500010-W32  |
|                          | Tube Bush BLK Coupler G2100                    | 1500010-B32  |
| <b>Fabric Assemblies</b> |  |              |
|                          | Fabric Assy G1500 6' x 39"                     | 8000010-06   |
|                          | Fabric Assy G1500 8' x 39"                     | 8000010-08   |
|                          | Fabric Assy G1500 10' x 39"                    | 8000010-10   |
|                          | Fabric Assy G1500 12' x 39"                    | 8000010-12   |
|                          | Fabric Assy G1500 14' x 39"                    | 8000010-14   |
|                          | Fabric Assy G2000 10' x 5'                     | 8000015-10   |
|                          | Fabric Assy G2000 12' x 5'                     | 8000015-12   |
|                          | Fabric Assy G2000 14' x 5'                     | 8000015-14   |
|                          | Fabric Assy G2000 16' x 5'                     | 8000015-16   |
|                          | Fabric Assy G2000 18' x 5'                     | 8000015-18   |
|                          | Fabric Assy G2000 19'8" x 5'                   | 8000015-198  |
|                          | Fabric Assy G2000 21'8" x 5'                   | 8000015-218  |
|                          | Fabric Assy G2000 22'11" x 5'                  | 8000015-2211 |
|                          | Fabric Assy G2000 12' x 6'7"                   | 8000020-12   |
|                          | Fabric Assy G2000 14' x 6'7"                   | 8000020-14   |
|                          | Fabric Assy G2000 16' x 6'7"                   | 8000020-16   |
|                          | Fabric Assy G2000 18' x 6'7"                   | 8000020-18   |
|                          | Fabric Assy G2000 19'8" x 6'7"                 | 8000020-198  |



|   |  |              |
|---|--|--------------|
|   | Fabric Assy G2000 21'8" x 6'7"         | 8000020-218  |
|   | Fabric Assy G2000 22'11" x 6'7"        | 8000020-2211 |
|   | Fabric Assy G2000 12' x 8'             | 8000025-12   |
|   | Fabric Assy G2000 14' x 8'             | 8000025-14   |
|   | Fabric Assy G2000 16' x 8'             | 8000025-16   |
|   | Fabric Assy G2000 18' x 8'             | 8000025-18   |
|   | Fabric Assy G2000 19'8" x 8'           | 8000025-198  |
|   | Fabric Assy G2000 21'8" x 8'           | 8000025-218  |
|   | Fabric Assy G2000 22'11" x 8'          | 8000025-2211 |
|   | Fabric Assy G2000 12' x 9'9"           | 8000030-12   |
|   | Fabric Assy G2000 14' x 9'9"           | 8000030-14   |
|   | Fabric Assy G2000 16' x 9'9"           | 8000030-16   |
|   | Fabric Assy G2000 18' x 9'9"           | 8000030-18   |
|   | Fabric Assy G2000 19'8" x 9'9"         | 8000030-198  |
|   | Fabric Assy G2000 21'8" x 9'9"         | 8000030-218  |
|   | Fabric Assy G2000 22'11" x 9'9"        | 8000030-2211 |
| <b>Valance Assemblies</b>   |  |              |
|   | Valance Fabric Assy 10' x 8" Drop      | 2081000-05   |
|   | Valance Fabric Assy 12' x 8" Drop      | 2081200-15   |
|   | Valance Fabric Assy 14' x 8" Drop      | 2081400-03   |
|   | Valance Fabric Assy 16' x 8" Drop      | 2081600-15   |
|   | Valance Fabric Assy 18' x 8" Drop      | 2081800-02   |
|   | Valance Fabric Assy 19'8" x 8" Drop    | 2081900-04   |
|   | Valance Fabric Assy 21'8" x 8" Drop    | 2082108-02   |
|   | Valance Fabric Assy 22'11" x 8" Drop   | 2082211-04   |
|   | Valance Fabric Assy 32' x 8" Drop      | 2083200-00   |
|   | Valance Fabric Assy 21'8" x 10" Drop   | 2102108-00   |
|   | Valance Fabric Assy 22'11" x 10" Drop  | 2102211-00   |
| <b>G1500 Motor Assemblies</b>   |  |              |
|   | Motor Assy 12volt w/o Manual Override  | 97GA45DS-35  |
|   | Motor Assy Standard w/ Manual Override | 97GA45M-30   |
|   | Motor Assy 45-30 Remote                | 97GA45RM-30  |
| <b>G2000 Motor Assemblies</b>   |  |              |
|   | Motor Assy 220volt w/ Manual Override  | 9702550-00   |
|   | Motor Assy 12volt w/ Manual Override   | 97GA45DM-50  |
|   | Motor Assy 12volt w/o Manual Override  | 97GA45DS-35  |
|   | Motor Assy Standard w/ Manual Override | 97GA45M-50   |
| <b>Backing Plate Kits (Includes: Backing Plate &amp; Mounting Hardware)</b> |  |              |
|   | Backing Plate Kit 54" - 12'            | 3400000      |
|   | Backing Plate Kit 12'1" - 18'          | 3400001      |
|   | Backing Plate Kit 18'1" - 22'11"       | 3400002      |



| <b>Mounting Bracket Kits (Includes: XL Bracket &amp; Mounting Hardware)</b> |   |             |
|---|---|-------------|
|   | XL Mtg Bracket 75degree SS              | 3400017     |
|   | XL Mtg Bracket 90degree SS              | 3400018     |
|   | XL Mtg Brkt Kit 75 degree               | 3400020     |
|   | XL Mtg Brkt Kit 90 degree               | 3400021     |
| <b>Fairings and Fairing Kits</b>  |   |             |
|   | Fairing Smth RR Pass-Side XL2           | 3400110-11  |
|   | Fairing Smth RF Pass-Side XL2           | 3400110-21  |
|   | Fairing Smth LR Driver-Side XL2         | 3400110-32  |
|   | Fairing Smth LF Driver-Side XL2         | 3400110-42  |
|   | Fairing Smth Std-Mt LH Rear 2004        | 3400112-01  |
|   | Fairing Smth Std-Mt RH Front 2004       | 3400112-02  |
|   | Fairing Set XL Pass-Side Front          | 3400010-10  |
|   | Fairing Set XL RR Pass-Side/LR Dvr-Side | 3400010-13  |
|   | Fairing Set XL Driver-Side Front        | 3400010-20  |
|   | Fairing Set Std Surface-Mt 2004         | 3400012-00  |
| <b>Coupled Awning Coupler Kits</b>  |   |             |
|   | Awning Coupler Kit w/o Fabric           | 1500010-001 |
|   | Awning Coupler Kit - 5' (1.5m)          | 1500010-00  |
|   | Awning Coupler Kit - 6'7" (2.0m)        | 1500011-00  |
|   | Awning Coupler Kit - 8' (2.5m)          | 1500012-00  |
|   | Awning Coupler Kit - 9'9" (3.0m)        | 1500013-00  |
|   | Awning Coupler Kit - 11'6" (3.5m)       | 1500014-00  |
|   | Awning Coupler Kit - 12'4" (3.75m)      | 1500015-00  |
|   | Fabric Coupler Strip 15" x 9'9"         | 8000030-125 |