

DIGITAL FORCE GAUGE MANUAL

Thank you for purchasing HF series digital force gauge!

The force gauge has advantages of high precision, easy operation and carry. What's more, it has kinds of testing modes, convenience for conner and it can store and input data to computer for statistical analysis as well as constitutes testers with different functions, combining with test-beds and clamp. Users can input local acceleration of gravity value to make test more precise.

I Functional characteristics

1. High precision and high resolution.
2. Five testing modes and three display methods for selection----enhancetesting efficiency to the maximum extent
3. N (Newton), kg (Kilogram) and lb (Pound) three measuring units for selection and conversion.
4. Setting function of gravity acceleration----User can input at your option the accurate value of gravity acceleration at the using place so as to make the testing and unit conversion be more accurate.
5. Function of peak value maintaining. Maintain the display of peak value until manual zero clearing.
6. Automatic peak function. Maintain the display of peak value for 2 seconds and then release automatically.
7. Max and min and comparison value can be set for statistic analysis. The buzzer will alarm if exceeding comparison value.
8. Data storage function. 896 testing values can be stored.
9. Data output function. The data can be input into computer through data line for various analyses.
10. Environmental protection. The device will automatically stop if no operation within 10 minutes.
11. High quality chargeable power supply. The charging voltage is avai-able from 100V to 240V, which can accommodate most areas in domestic and at abroad. It has also protection functions for short circuit, leakage and overload.
12. 2 sets mounting dimensions, it is applied for most testing platforms domestically and easy for users to install it to platform.
13. Special testing function of make-break ability of switch contact to make the make-break testing be more accurate.
14. 6 digits large screen display.
15. Synchronous measuring software can connect computer measuring, the computer display measuring graph and the detailed testing records, and can preserve, print ,make analysis, input speed, area, displacement, pressure. (chosen function details see CD data)
16. Contact control signal output setting comparative value, when the Measuring value is over comparative value, output signal control circuit Breaker's make-and-break,

thus realize the function of stop electromotor, And control automatically; it is also can be used for realize other control Functions, for example input signal to plc to realize automatization. Also it can set signal output mode, for example output signal at some Measuring range. There is a jack on the side of apparatus can put one Side of connection line to secondary jack, and the other side in the jack On the testing machine which is produced by our company, thus it can Realize function of stop electromotor automatically when the measuringValue is over comparative value. The comparative value can set by himself.

17. Negative phototropism function use key-press or apparatus is stressed, the negative photo tropism would light automatically, it will close negative phototropism if 10s non-operation; it also can press "setting" key 6 times ,enter 'light" condition, choose "NO" to close negative phototropism, chose "YES" to start the function automatically.

18. LCD overturn display press "print" key can make the value reverse 180°, convenience for looking the measuring value from different angle.

19. Reset quickly when system halted accidentally install reset key on the side , then press the key swith forcibly can make power off.

20. Digit force gauge has many specifications for users' choosing, and customers can choose corresponding apparatus according to the force value of their measuring products. The measuring range should be 10%-100% of the full range, measuring department suggest not use less than 1% of the full range, so this apparatus shield the range. At the same time, press "zero setting" key to clear the weight of clamp before the measurement.

II. Force gauge mode specification sheet (see table 1 and table 2)

Model specification sheet of force gauge with inner sensor

Model specification		HF-2	HF-5	HF-10	HF-20	HF-50	HF-100	HF-200	HF-500	HF-1000
Peak load value	N	2	5	10	20	50	100	200	500	1000
	kg	2	0.5	1	2	5	10	20	50	100
	lbs	0.44	1.1	2.2	4.4	11	22	44	110	220
load division value	N	0.001	0.001	0.01	0.01	0.01	0.1	0.1	0.1	1
	kg	0.0001	0.0001	0.001	0.001	0.001	0.01	0.01	0.01	0.1
	lbs	0.0001	0.0001	0.001	0.001	0.001	0.01	0.01	0.01	0.1
Indication error		0.50%								
Unit		N / kg / lbs								
Data interface		Rs232 nine-hole socket								
Power		rechargeable batteries, charger(charging voltage 100V-240V)								
Sensor structure		S-type sensor with high precision (inner sensor)								
Ambient temperature		5° C~35° C								

Transport temperature	-10° C~60° C
Relative humidity	15%~80%RH
Working conditions	No hypocenter and corrosive medium
Gross weight	~2000g
Size	273 x 182 x70 mm

Model specification sheet of force gauge with external sensor

Model specification	HF2000	HF5000	HF10K	HF20K	HF50K	HF100K	HF200K	HF500K	HF1000K	
Peak load value	2000N	5000N	10KN	20KN	50KN	100KN	200KN	500KN	1000KN	
load division value	1N	1N	0.01KN	0.01KN	0.01KN	0.1KN	0.1KN	0.1KN	1KN	
	0.1kg	0.1kg	0.001Mg	0.001Mg	0.001Mg	0.01Mg	0.01Mg	0.01Mg	0.1Mg	
	0.1lbs	0.1lbs	0.001Klbs	0.001Klbs	0.001Klbs	0.01Klbs	0.01Klbs	0.01Klbs	0.1Klbs	
Indication error	±0.5%						±1%			
Unit	N / (KN), kg / (Mg or t), lbs (Klbs)									
Data interface	Rs232 nine-hole socket									
Power	rechargeable batteries, charger(charging voltage 100V-240V)									
Sensor structure	S-type or column sensor with high precision (external sensor)									
Ambient temperature	5° C~35° C									
Transport temperature	-10° C~60° C									
Relative humidity	15%~80%RH									
Working conditions	No hypocenter and corrosive medium									
Gross weight	6 kg			9 kg			24 kg		36 kg	
Size	280 x 200 x 170 mm						310 x 260 x 190 mm			

Model specification	HF3000K
Peak load value	3000KN
load division value	1KN

	0.1Mg
	0.1Klbs
Indication error	±1%
Unit	N / (KN), kg / (Mg or t), lbs (Klbs)
Data interface	Rs232 nine-hole socket
Power	rechargeable batteries, charger(charging voltage 100V-240V)
Sensor structure	S-type or column sensor with high precision (external sensor)
Ambient temperature	5° C~35° C
Transport temperature	-10° C~60° C
Relative humidity	15%~80%RH
Working conditions	No hypocenter and corrosive medium
Gross weight	36 kg
Size	310 x 260 x 190 mm

III.Safe cautions

Cautions

If the operation is wrong, the apparatus may be damaged and serious accident may be occur. The manual indicate important items for prevent accidents and the use method, please read it carefully before using the apparatus. Safekeep it after reading in case of read it again. If measuring impulse load, please choose the type whose peak load is double of that impulse load.

Warning

1.when destructive testing, users should wear protection mask and gloves in case of splash matter injury body.

2. Don't use damaged or seriously curving and transformative clamp.self-made clamp should refer to the relevant parameter of this manual (our company also provide kinds of clamp, customers can purchase additionally according to demands)

Safe cautions

1. Please use complement charger to charge, or it may result in circuit failure and even fire.

2. Don't use power except charger's rated voltage, or it may result in electric shock and fire.

3. Don't use wet hand to pull or plug socket, or it may result in electric shock.

4. Don't pull the power wire of charger to pull socket, avoid the wire break and thus suffer electric shock.

5.please clean the gauge by soft cloth. Immerge the cloth in water with cleanser, dry it and then use it to clear dust and dirt.

Note: don't use volatile chemical substances to clean (for example propellant, thinner and alcohol)

6. Please don't operate this gauge at following environment

(1) moist environment

(2) dusty environment

(3) the place where use oil and chemical substances

(4) the place where has hupocenter around

7. Please use and store at the range of stated temperature and humidity,or it may result in apparatus failure.

8. Don't tear, repair and change this gauge by yourself, because these actions may result in permanent fault of apparatus.

9.other safe cautions.

IV.Structure names

Strictire names of force gauge refer to chart 1 and chart 2.

Chart 1 structure names graph

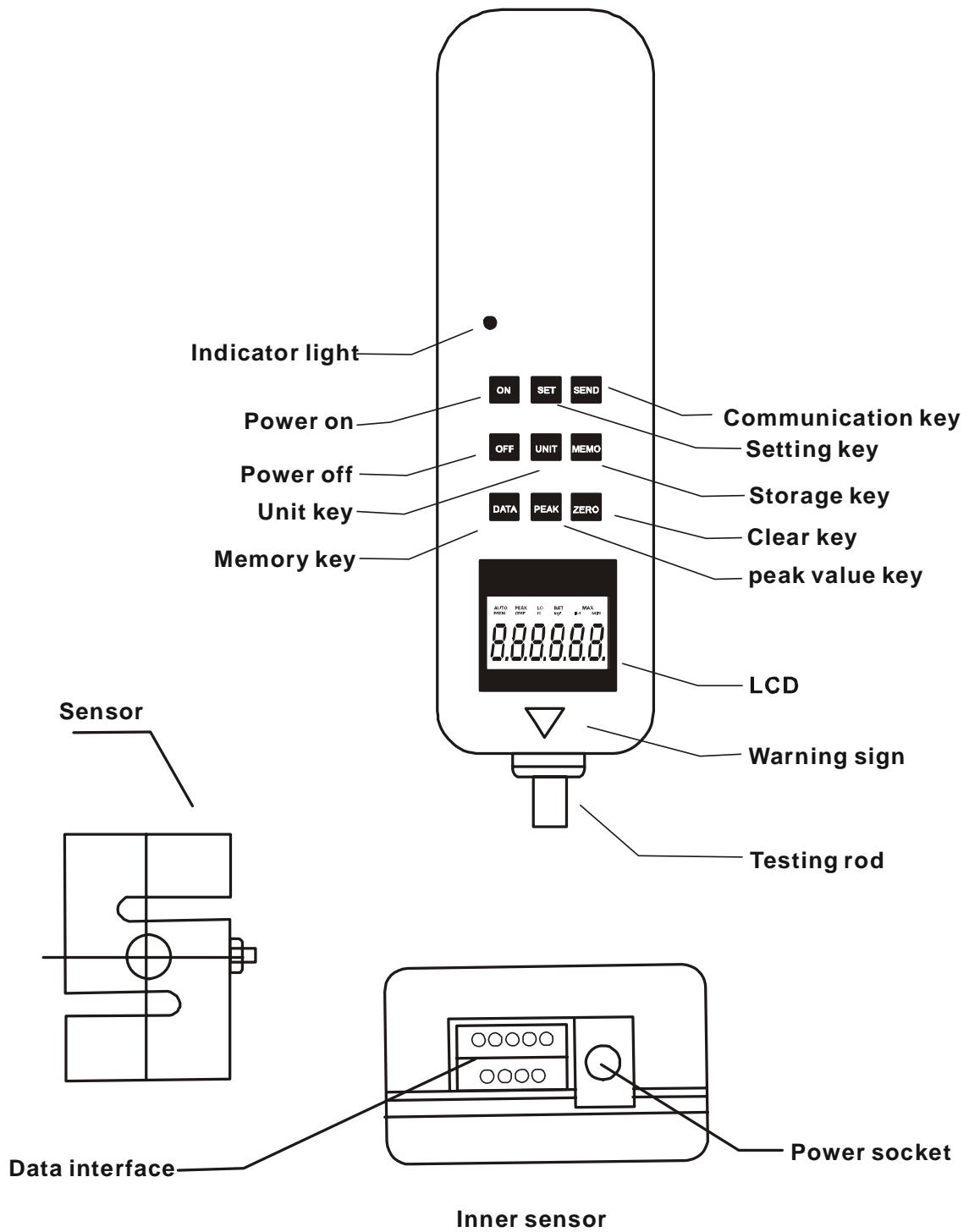
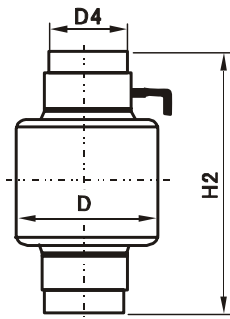
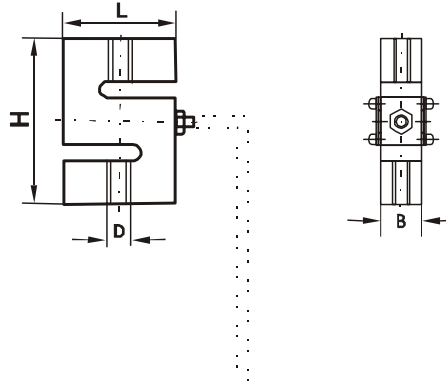

Chart 2 structure names graph

measuring range (kg)	D	L	H	B
200-500	M12	51	76.2	19.1
1000	M12	51	76.2	25.4
2000-5000	M20*1.5	76.2	100.4	31.8

Column sensor



Measuring range (t)	H2	D	D4
10 20	139.8	Φ76	Φ40
50	150	Φ84	Φ44

Column sensor

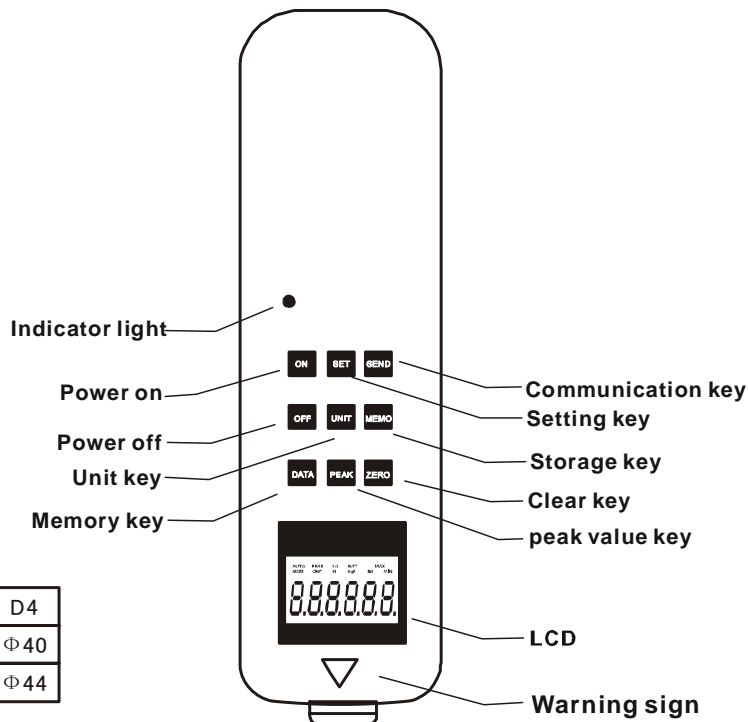

V.Screen display declaration

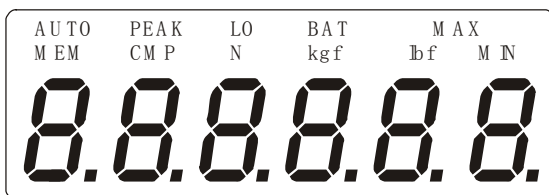

1. PEAK

When "PEAK" is displayed, it indicates Peak mode (Peak maintaining mode), and the displayer will maintain the display the peak value until manual zero clearing. When "AUTO PEAK" is displayed, it indicates "auto peak" (Automatic release mode of peak maintaining), and the display of peak value will be maintained for 2 seconds and then is cleared automatically. When no "PEAK" is displayed, it indicates "track mode" (Real-time load value mode), the value on the screen will change accordingly with the load.

2. LO BAT

When the voltage drops under 7.0V, the screen will display "LO BAT", which indicates the voltage is inadequate and it requires charging (Testing can be carried out during charging)

3. MEM

If the data is stored and memorized, "MEM" will be displayed. When pressing "DATA" button to check memorized data, "MEM" will flash.

4.in this gauge, thrust (tension) default is negative value(“-”), pull value is positive value (“+”not display)

5. CMP

Comparative function.

When setting comparative value through CPDT, the function is activated. "CMP" displays. Comparative default is regarded as full measuring range, it can set according to demand when using.

VI.Key-press declaration (see following chart)

ON	SET	SEND
OFF	UNIT	MEMO
DATA	PEAK	ZERO

1. ON button

Press the button, and the power will be on. At the same, "ON" indicator lamp will be on (The indicator lamp will also be on when charging.) and the model will be displayed. After the apparatus is started, before zero clearing by pressing Zero button, the screen may display similar signal of drifting zero point value, just press Zero button to clear.

2. OFF button

Whenever the button is pressed, the power is cut off. The memorized data will never disappear.

3. DATA button

Press this button, the stored testing data (Memorized data) will be recalled in turn and displayed on the screen. At the time, “MEM” will flash----firstly the DATA times will be displayed, after 2 seconds, the memorized data will be automatically displayed. Press Peak button to exit DATA.

4. Unit button

Press this button to carry out conversion between measuring units. Three units such as N (Newton), kg (Kilogram) and lb (Pound) can be displayed circularly. Under the display status of testing data, the unit conversion of the same value can be completed. In the specifications above HF10K, the units can be combined with the alphabet "K" into KN (Kilo-Newton)", "(Ton)" and "Klb (Kilo-pound)".

5. PEAK button

Press this button each time, the switching of display of "PEAK", display of "AUTO PEAK" and disappearance of "PEAK" can be realized. That is, the switching of peak value maintaining, automatic release of peak value maintaining and real-time load value mode.

6. PRINT button

Under the status of power off, press this button and then press ON button, the stored testing data will be output to computer through data wire for computer communication. After the communication is finished, press Peak button to power off. Under the status of "MODE" setting, press this button to make the flashing digit change between "0" and "9".

7. MEMO button

When pressing this button, the testing data displayed on the screen will be stored. The stored data can be recalled through using the DATA button. The data can be removed by Zero button, and through PRINT button, they can be output to computer for analysis or printing. If testing data are stored in the apparatus, "MEM" will be displayed.

8. ZERO button

After pressing this button, the testing value on the screen will be cleared.

※ When the weight of used fixtures exceeds 20% of measurement range or the apparatus has load exceeding 20% of measurement range, the zero clearing can't be finished by pressing Zero button. At the time, select lighter fixtures or remove the added load to clear again.

※ Press this button for 4 seconds, the stored testing data will be completely cleared. (Under some conditions, the clearing may not be completed. Power off and power on again to execute the function, all the memorized data can be cleared.)

9. SET button

Detailed setting refer to setting declaration of setting mode in " functional setting

VII.SET Button functional setting

Under the status of power on, press SET button. At the time, the items to be set will be displayed. The item firstly displayed is "TEST", after 2 seconds, digit setting window will appear. Through SEND button and SET button, set the testing mode. Then press SET button, "AODT", "LODT", "HIDT" and "CPDT" will appear in turn. The digit setting window will be displayed automatically at the corresponding item after 2 seconds.

Set the required parameters through SEND button and MEMO button. "Setend" will be displayed, which indicates the setting is finished and enter into testing status.

TEST is expressed by four digits with the following definitions.

0000 real-time load value mode	0001 standard testing mode
0002 push-pull peak value mode	0003 pull peak value mode
0004 push peak value mode	0005 external contact break-make mode
0006 external contact make-break mode	
0000 real-time load value (Random tracking) mode	

Under any status, track the change display of testing load value. When the testing load

value disappears, return to the zero point. At the time, PEAK can't play its function.

0001 standard testing mode (Default ex-factory mode) Under the mode, three kinds of status can be set, that is, real-time load value status, peak value maintaining status and automatic peak value status. When there is no "PEAK" on the screen, it is under real-time load value status. The testing value will change accordingly with load. Press Peak button, "PEAK" will be displayed, and it is under peak maintaining status. The testing value displayed is the maximum value in the test (Whatever pull force or pressure). It requires manual clearing. Press PEAK button again, "AUTO PEAK" will be displayed, and it is under automatic peak status. The testing value displayed is the maximum value in the test (Whatever pull force or pressure), and after 2 seconds display, the value will automatically disappear and be cleared. Enter into the next test.

0002 push-pull peak value mode-----Seize the function of maximum load value at the two directions of pressure and pull force. During connector testing, seize the function of maximum load value (F_c , F_t) of positive and negative directions of push force and pull force.※ When the load added at positive and negative directions is larger than sensing value F_a and the load is lower than F_a , one time (One circle) testing is completed (finished). The sensing value must be set (Sensing range).

0003 pull peak value mode-----During push-pull testing, just seize the function of maximum load (F_t) of pull force.

0004 push peak value mode-----During push-pull testing, just seize the function of maximum load (F_c) of push force.

0005 0006 switch contact make-break testing mode-----Measure the accurate load value during the instant action of making and breaking of contact.

0005 instant maximum force of external contact from breaking to making Connect the 2 tested contacts separately into 4 and 5 feet on the data interface (Through data plug in the accessories), press PEAK button to select peak mode, exert pressure onto the switch with push-pull force meter until the switch is connected. The force value measured at the time is the force value required for making the switch.

0006 instant maximum force of external contact from making to breaking Connect the 2 tested contacts separately into 4 and 5 feet on the data interface (Through data plug in the accessories), press PEAK button to select peak mode, exert pressure onto the switch with push-pull force meter until the switch is disconnected. The force value measured at the time is the force value required for breaking the switch. As shown in the following figure, the load tested is carried out with the operation of switch and button.

Set it under "PEAK" status, F_p is the tested data value.

When the added load is larger than the setting value of F_a , until the contact changes from breaking to making or from making to breaking, the load value on the screen will stop its change. At the time, the value displayed is the tested value.

※ Please connect PIN 4 and PIN 5 of data interface as the contact signal (Through the data plug in the accessories).

※ If F_a is not set (Sensing range), the testing can't be carried out.

AODT Setting of sensing value

When push and pull are tested at the same time, set the sensing value F_a . For example:

In push force testing, if the value exceeds sensing value, it indicates "Push" to start the testing, and then, the value will be lower than sensing value, which indicates the push force testing is finished. Contrarily, the pull force testing at reverse direction can be carried out. If the value exceeds sensing value, it indicates "Pull" start the testing, and then, the value will be lower than sensing value, which indicates the pull force testing is finished.

LODT Setting of Min

Set the Min of testing value, if a value is lower than Min, the value will exceed the range and "MIN" will be displayed.

HIDT Setting of Max

Set the Max of testing value, if a value is higher than Max, the value will exceed the range and "MAX" will be displayed.

CPDT Setting of comparison value

When the testing value exceeds the set comparison value, the buzzer will alarm.

LODT, HIDT and CPDT are used together to make the apparatus have analysis and judgment ability to testing data. When user is not clear about the debugging, (it's better to return to power on status after power off) , press Setting button for more than 4 seconds, leave hands until hearing "DI" sound, the apparatus can return to the default ex-factory value status. The values are shown as follows:

TEST: 0001 standard testing mode; AODT, LODT: 1% of full measurement range

HIDT, CPDT: full measurement range.

VIII. Testing

Press power on key, test directly using default according to demand or test after measuring mode choosing pressing setting key.

1. choose proper measuring junction and install clamp to force gauge(self-made clamp should refer to relevant data of " outline and mounting dimension chart ")
2. please grasp force gauge firmly or install it to proper testing machine for testing, make measured force and force gauge's rod in line when testing in order to get accurate weight value.
3. After testing, unlade load and close power, take clamp, then clean kinds of goods and replace to toolbox in case next using.

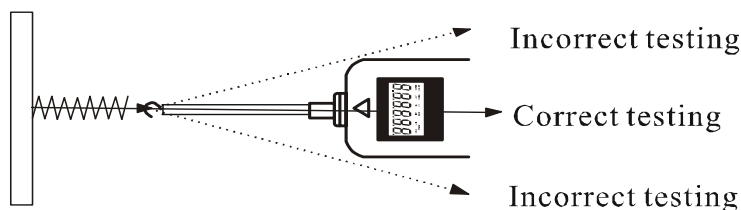

IX. Data storage (memory)

1. Data storage

Only under the status of peak value maintaining (PEAK), after the testing is finished,

by pressing Storage button, the data can be stored. "MEM" will be displayed on the screen. The stored data can be also saved after power off. When browsing memorized data by using Memory button, "MEM" will flash. Memory times will first appear, and after 2 seconds, memory value will automatically appear. Press PEAK button to exit the memory and directly enter into testing. The data can also be input into computer for analysis. The apparatus can store 896 data. When "0.E" is displayed, it indicates the No. 897 data can't be stored.

2. Memory clearing

Under the status of general load display, press Zero button for more than 4 seconds, all the memorized data will be completely cleared and "MEM" will disappear. The apparatus can be connected to computer and testing data can be input into computer. Browse and print testing times, average value, maximum value and minimum value and judge if the testing results are in accordance with the requirements.

X. Acceleration of gravity alteration

Users can input local acceleration of gravity by himself. Press peak key before power on and then press power on key, thus enter to acceleration of gravity setting interface, after new acceleration input, press setting keypad the system off. It can be used when the power on.

XI. Other cautions

Affirm items before the force gauge's repair

	Symptom	cause or phenomenon	Treatment
Power	press power on key has no display	batteries has no electricity	Recharge
	can't charge	converter of unconformity when charging	please affirm: AC110V→DC9.4V AC220V→DC9.4V
Testing value	inaccurate testing value	error is too big	poise proofread value (refer to proofread method)
other	parameter chaos	SET setting error	press setting key for more than 4s to reset delivery setting
	system halted accidentally	has no reflection by pressing any key	press "reset" key

XII. Data interface (9PIN)

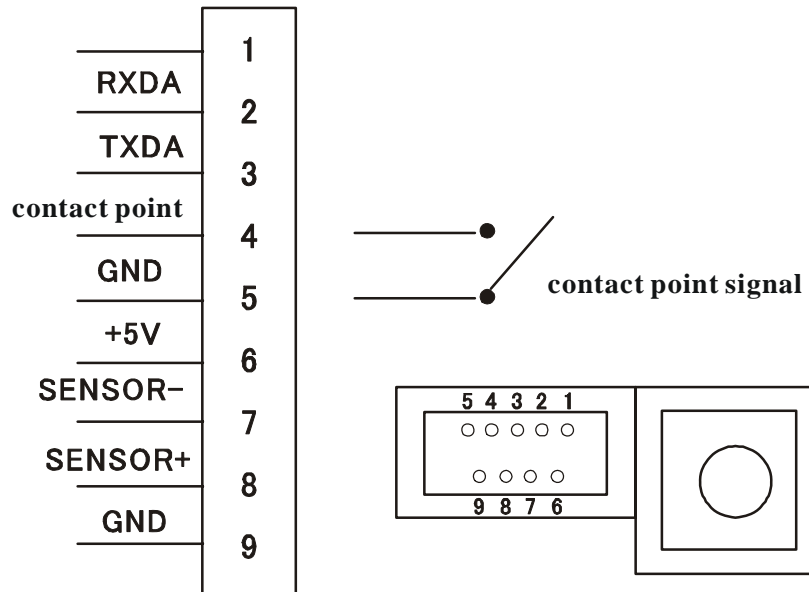

PIN	FUNCTION
PIN4 PIN5	CONTACT POINT SIGNAL
PIN2 PIN7 PIN8 PIN9	STRUCTURE NAMES GRAPH
PIN2 PIN3 PIN9	RS 232 INTERFACE TO COMPUTER

XIII.Outline and mounting dimension chart

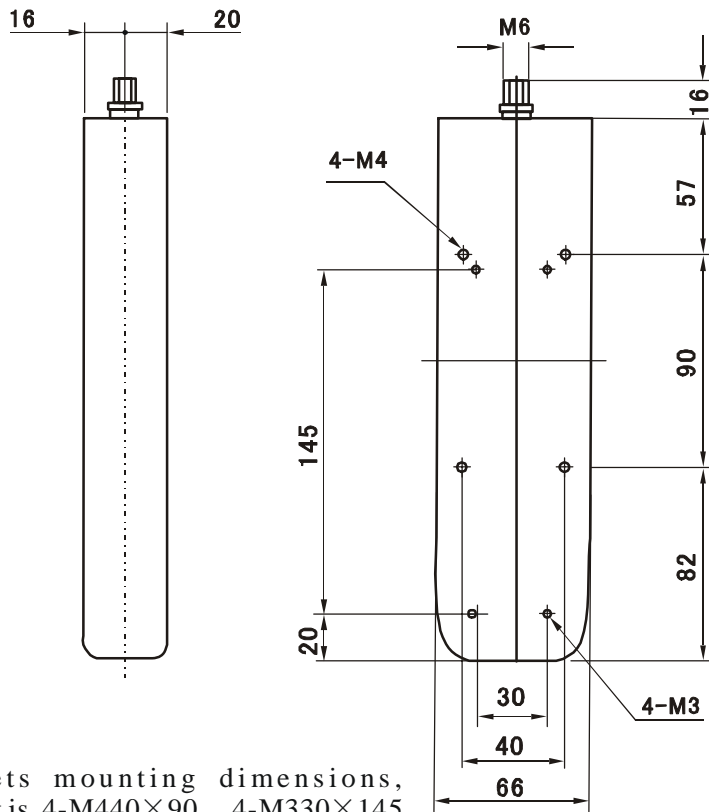

Sets mounting dimensions,
that is 4-M440×90 4-M330×145

XIV. Stochastic appurtenance list

No. Quantity Name	Compressed clamp	Stretching clamp	Extended bar	Assistant socket	Computer line	Mounting screw	Manual	Inspection certificate	Charger	Software
HF-2	4	1	1	1	1	8	1	1	1	1
HF-5	4	1	1	1	1	8	1	1	1	1
HF-10	4	1	1	1	1	8	1	1	1	1
HF-20	4	1	1	1	1	8	1	1	1	1
HF-50	4	1	1	1	1	8	1	1	1	1
HF-100	4	1	1	1	1	8	1	1	1	1
HF-200	4	1	1	-	1	8	1	1	1	1
HF-500	4	1	1	-	1	8	1	1	1	1
HF-1000	4	1	1	-	1	8	1	1	1	1
HF-2000	3	2	-	-	1	-	1	1	1	1
HF-5000	3	2	-	-	1	-	1	1	1	1
HF-10K	3	2	-	-	1	-	1	1	1	1
HF-20K	3	2	-	-	1	-	1	1	1	1
HF-50K	3	2	-	-	1	-	1	1	1	1
HF-100K	Own sensor	-	-	-	1	-	1	1	1	1
HF-200K	Own sensor	-	-	-	1	-	1	1	1	1
HF-500K	Own sensor	-	-	-	1	-	1	1	1	1
HF-1000K	Own sensor	-	-	-	1	-	1	1	1	1

HF-3000 K	Own sensor	-	-	-	1	-	1	1	1	1
--------------	---------------	---	---	---	---	---	---	---	---	---