

REVISION RECORD			
LTR	ECO NO:	APPROVED:	DATE:

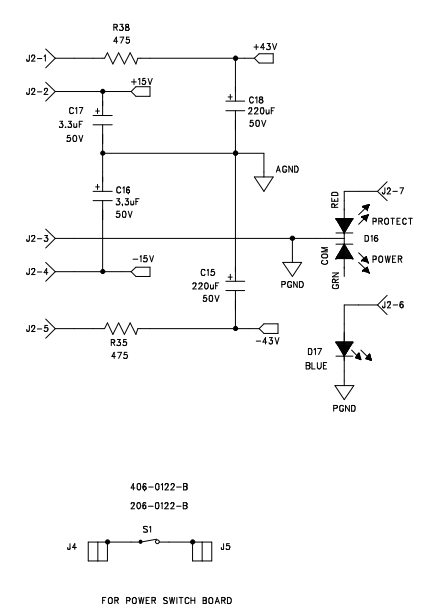
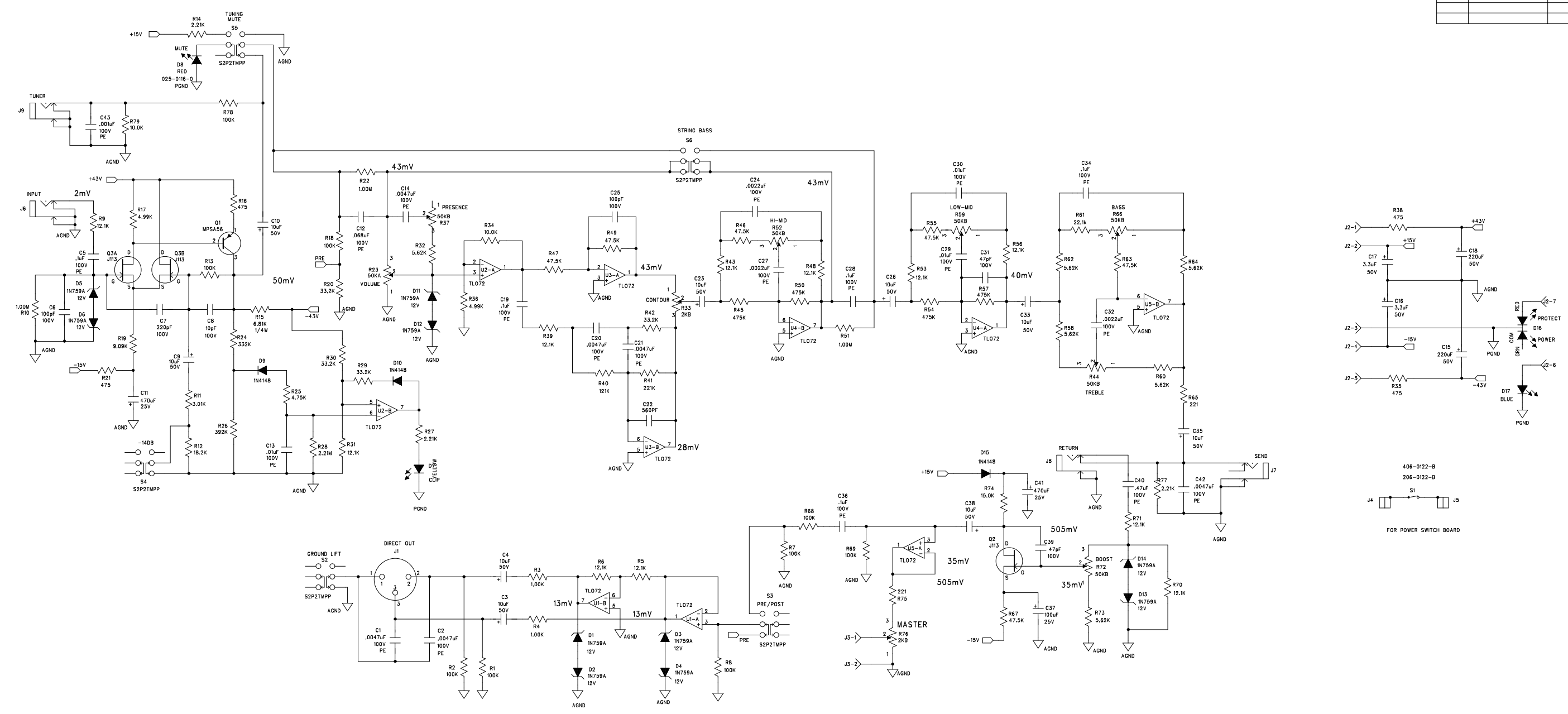

NOTES: UNLESS OTHERWISE SPECIFIED,
 1. All test point voltages are in RMS, with 200 Hz, 2 mV (-53.9 dBV) sine wave input.
 2. CONTOUR and PRESENCE on zero (off).
 Switches out, all tones, boost and volume on 10

MH125NP X1

NOT VALID UNLESS STAMP IS RED

gallien technology

2240 PARAGON DRIVE
 SAN JOSE CA. 95131
 VOICE: 408-441-8081
 FAX: 408-441-8085

1. UPDATE HOLE & PAD SIZE.		2. CHANGE BOARD # FROM 0120-E1 TO 0241-A.	
APPROVALS		TITLE: 400RB-IV PREAMP	
INIT	DATE	REV	DRAWING NO: 406-0241-A
DESIGNED: R.A.G.	5/19/99	B	PART NO: 206-0241-A
DRAWN: R.A.G.	11/27/02		COMPANY: GALLIEN-KRUEGER
ELEC:			FILENAME: 6241A
MECH:			
D/A:			
RELEASED:			

GK GALLIEN-KRUEGER

400RB-IV Preamp 206-0241-A

Part No.	Reference	Description	Manufacturer	Mfr. Part No.
001-1030-1	U1-5	TLO72CP, LOW NOISE JFET OPAMP	MOTOROLA	TL072CP
010-1013-0	Q1	MPSA56 PNP 80V 500MA TO-92	MOTOROLA	MPS-A56
010-2010-0	Q2 Q3A Q3B	J113,N-JFET,35V,2MA,TO-92	NATIONAL	J113
020-0120-0	D1-6 D11-14	1N759A, ZENER,12V,5%,400MW, DO-35	MOTOROLA	1N759A
020-1000-0	D9-10 D15	1N4148, RECT-FAST, 200MA, 100V	MOTOROLA	1N4148
025-0012-0	D16	LED,RED/GRN,5MM,630NM/560NM,15MCD/1	STANLEY	VRPG5614S
025-0023-0	D7	LED,YELLOW, 3MM, 585NM, 5MCD, 10MA	EVERLIGHT	EL204YD
025-0030-2	D17	LED,BLUE, 10MA	LITEON	LTL-42B6
025-0116-0	D8	LED,RED, 3MM, 635NM, 6MCD, 10MA, 40DE	EVERLIGHT	EL2041D
031-1107-0	C37	CAP,ELEC,RAD,107,20%,25V	UNITED CHEMI-CON	SMG25VB101M6X11LL
031-1477-0	C11 C41	CAP, ELEC, RAD, 470uF, 20%, 25V	UNITED CHEMI-CON	SMG25VB471M10X12LL
031-2106-0	C3,4,9,10,23,26,33,35 C38	CAP,ELEC,RAD, 106, 20%, 50V	UNITED CHEMI-CON	SMG50VB10RM5X11LL
031-2227-0	C15 C18	CAP, ELEC, 220uF, 20%, 50V	UNITED CHEMI-CON	SMG50VB221M10X12LL
031-2335-0	C16-17	CAP,ELEC,RAD,335,20%,50V	UNITED CHEMI-CON	SMG50VB3R3M5X11LL
032-4102-0	C43	CAP,PE,102,5%,100V,	PANASONIC	ECQB1102JF
032-4103-0	C13 C29-30	CAP,PE,103,5%,100V,	PANASONIC	ECQV1103JM
032-4104-0	C5 C19 C28 C34 C36	CAP,PE,104,5%,100V,	PANASONIC	ECQV1104JM
032-4222-0	C24 C27 C32	CAP,PE,222,5%,100V,	PANASONIC	ECQB1222JF
032-4472-0	C1-2 C14 C20-21 C42	CAP,PE,472,5%,100V,	PANASONIC	ECQB1472JF
032-4474-0	C40	CAP,PE,474,5%,100V,	PANASONIC	ECQV1474JM
032-4683-0	C12	CAP,PE,683,5%,100V,	PANASONIC	ECQV1683JM
034-4100-0	C8	CAP, MCR,10pF,5%,100V,NPO	TAITRON	TMRS100J100NPOB
034-4101-0	C6 C25	CAP,MCR,100pF,5%,100V,	TAITRON	TMRS101J100NPOB
034-4221-0	C7	CAP,MCR,220pF,5%,100V,	TAITRON	TMRS221J100NPOB
034-4470-0	C31 C39	CAP,MCR,47PF,5%,100V,NPO	TAITRON	TMRS470J100NPOB
034-4561-0	C22	CAP,MCR,560pF,5%,100V,	TAITRON	TMRS561J100NPOB
052-6812-0	R15	RES, METAL FILM, 6.81K, 1/4W, 1%	ECI	M2F1AK006.81
060-1002-0	R3-4	RES,METAL FILM, 1.00K, 1/8W, 1%	ECI	M1F1AK001.00
060-1003-0	R34 R79	RES,METAL FILM, 10.0K, 1/8W,1%	ECI	M1F1AK010.00
060-1004-0	R1,2,7,8,13,18,68,69,78	RES,METAL FILM, 100K, 1/8W, 1%	ECI	M1F1AK100.00
060-1005-0	R10 R22 R51	RES, METAL FILM, 1.00M, 1%,1/8W	ECI	M1F1AM001.00
060-1213-0	R5,6,9,31,39,43,48,53 R56,70,71	RES,METAL FILM, 12.1K, 1/8W, 1%	ECI	M1F1AK012.10
060-1214-0	R40	RES,METAL FILM, 121K, 1/8W, 1%	ECI	M1F1AK121.00
060-1503-0	R74	RES,METAL FILM, 15.0K, 1/8W, 1%	ECI	M1F1AK015.00
060-1823-0	R12	RES,METAL FILM, 18.2K, 1/8W, 1%	ECI	M1F1AK018.20
060-2211-0	R65 R75	RES,METAL FILM, 221, 1/8W, 1%	ECI	M1F1AJ221.00
060-2212-0	R14 R27 R77	RES,METAL FILM, 2.21K, 1/8W, 1%	ECI	M1F1AK002.21
060-2213-0	R61	RES,METAL FILM, 22.1K, 1/8W, 1%	ECI	M1F1AK022.10
060-2214-0	R41	RES,METAL FILM, 221K, 1/8W, 1%	ECI	M1F1AK221.00
060-2215-0	R28	RES, METAL FILM, 2.21M, 1/8W, 1%	ECI	M1F1AM002.21
060-3012-0	R11	RES,METAL FILM, 3.01K, 1/8W, 1%	ECI	M1F1AK003.01
060-3323-0	R20 R29-30 R42	RES,METAL FILM, 33.2K, 1/8W, 1%	ECI	M1F1AK033.20
060-3324-0	R24	RES,METAL FILM, 332K, 1/8W, 1%	ECI	M1F1AK332.00
060-3924-0	R26	RES,METAL FILM, 392K, 1/8W, 1%	ECI	M1F1AK392.00
060-4751-0	R16 R21 R35 R38	RES,METAL FILM, 475, 1/8W, 1%	ECI	M1F1AJ475.00
060-4752-0	R25	RES,METAL FILM, 4.75K, 1/8W, 1%	ECI	M1F1AK004.75
060-4753-0	R46,47,49,55,63,67	RES,METAL FILM, 47.5K, 1/8W, 1%	ECI	M1F1AK047.50
060-4754-0	R45 R50 R54 R57	RES,METAL FILM, 475K, 1/8W, 1%	ECI	M1F1AK475.00
060-4992-0	R17 R36	RES,METAL FILM, 4.99K, 1/8W, 1%	ECI	M1F1AK004.99
060-5622-0	R32,58,60,62,64,73	RES,METAL FILM, 5.62K, 1/8W, 1%	ECI	M1F1AK005.62
060-9092-0	R19	RES,METAL FILM, 9.09K, 1/8W, 1%	ECI	M1F1AK009.09
070-1513-0	R23	POT,50K-15A,7MM,KNURL,1W	SONG HUEI	16K1-A50K-L15KC
070-1514-0	R37,44,52,59,66,72	POT,50KB,7MM,KNURL,1W	SONG HUEI	16K1-B50K-L15KC
070-1522-0	R33 R76	POT,2KB,7MM,KNURL,1W	SONG HUEI	16K1-B2K-L15KC
090-0007-0	S1	SWITCH, 8A/128A,250V,PP,PCB	TECX	KDC-A04-10-B, B2-F
090-0012-0	S2-6	SWITCH,MIMI PP,DPDT,1A BRK/MAKE	ELKELECTRONIC COMP	MTH2UEE-1D911
092-0066-0	J4-5	FASTON, M, PC, .250"	KEYSTONE	1021
092-0081-0	J6-9	JACK,1/4",MONO,PC,NON GROUNDING	NEUTRIK	S102-84
092-0084-0	J1	CON,XLR,MALE,PC,PL, SCREW MNT	NEUTRIK	X906-05
093-0051-0	J3	HDR, 2MMX2, VERT, LOCK	JST	B2B-PH-K-S
093-2005-0	J2	HDR, 2MMX7, VERT, SHROUDED	JST	B7B-PH-K-S
145-0241-A		400RB-IV PREAMP RAW BOARD		

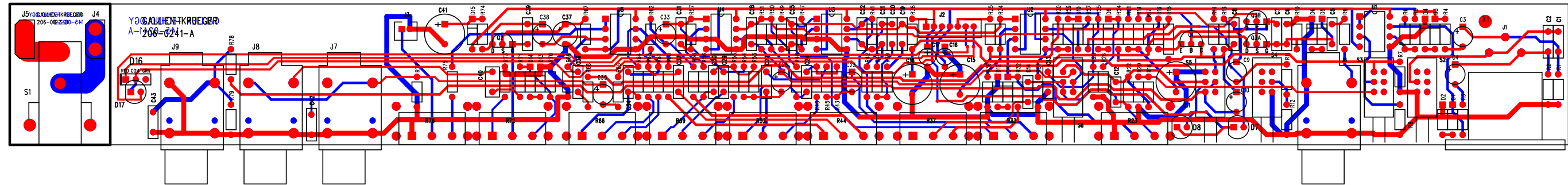

PCB WORK INSTRUCTIONS

DWG #420-0241-A

NOTES:

UNLESS OTHERWISE SPECIFIED:

1. SQUARE PADS ON THRU HOLE PARTS (ie: CONNECTORS, DIPS, SIPS, LEDS) DENOTE PIN 1.
2. ALL BOARDS REQUIRE A COMPLETE AND THOROUGH VISUAL INSPECTION.
3. ALL BOARDS MUST BE BARE BOARD TESTED.
4. ASSEMBLE AND SOLDER PER ANSI/IPC-A-610B.

LOADING

5. CLIP BUSHING TABS OFF ON POTS R23, 33, 37, 44, 52, 59, 66, 72, 76
6. SEE DETAIL A FOR MOUNTING D7 AND 8
7. SEE DETAIL "B" FOR MOUNTING D16 AND D17

FINAL QA

8. CHECK TO SEE ALL POTS, JACKS, AND SWITCHES ARE MOUNTED FLUSH AND STRAIGHT

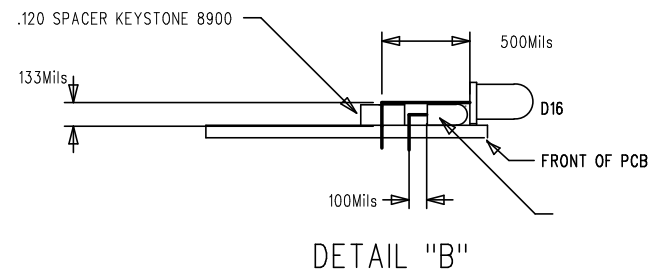
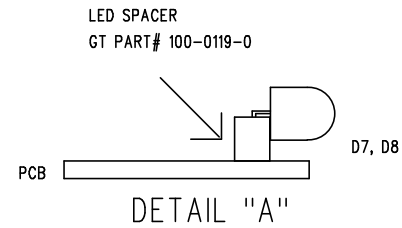

NOT VALID UNLESS STAMP IS RED		2240 PARAGON DRIVE SAN JOSE CA. 95131 VOICE: 408-441-8081 FAX: 408-441-8085	
gallien technology		TITLE: 400RB-IV PRE-AMP BD	
APPROVALS		SIZE: B	DRAWING NO: 405-0241-A
INIT	DATE	REV. A	
DESIGNED: R.A.G.	1/6/98	PART NO: 145-0241-A	
DRAWN: R.A.G.	11/27/02		
ELEC:		COMPANY:	
LAYER DESCRIPTION: TOP SIDE ROUTING		GERBER FILE NAME: 5241A	
MECH:		FILENAME: 5241A	

Customer Name:		Gallien-Krueger		Current Rev #:	A	New ECO Rev #:	A1		
Model:		400RB-IV		Distribute To:		Page:	1	Of:	1
Assembly Description:		Preamp		Originator: RAG					
Assembly Numbers:		206-0241-A1		Approved by:					
				Effective Date: 8/8/2003					
Effective				Document Update		Date	Initials		
<input type="checkbox"/>	All in Process	<input checked="" type="checkbox"/>	Next Buy	<input type="checkbox"/>	Artwork				
<input type="checkbox"/>	All in Service	<input type="checkbox"/>	Next Production Run	<input type="checkbox"/>	Assembly Dwg.				
<input type="checkbox"/>	All in Stock	<input type="checkbox"/>		<input checked="" type="checkbox"/>	Board Artwork				
Beginning Serial Number:				<input checked="" type="checkbox"/>	BOM				
Reason For Change				<input type="checkbox"/>	Control Form				
Update boost and gain structure to match 800RB.				<input type="checkbox"/>	Costing				
				<input type="checkbox"/>	Fab Drawing				
				<input checked="" type="checkbox"/>	Inspection Proc.				
				<input checked="" type="checkbox"/>	Part Master File				
				<input checked="" type="checkbox"/>	Schematic				
				<input type="checkbox"/>	Service Manual				
				<input checked="" type="checkbox"/>	Test Procedure				
				<input type="checkbox"/>					
				Other Affected Assemblies					
				290 Assembly, 302 Assembly (Head)					
				303 Assemblies (Combos)					
<input type="checkbox"/>	Continued on ECO Supplement Page								
Description Of Change				Distribution		Date	Initials		
Make changes as indicated below.				<input type="checkbox"/>	Accounting				
				<input type="checkbox"/>	Assembly				
				<input checked="" type="checkbox"/>	Engineering				
				<input checked="" type="checkbox"/>	Incoming Q.C.				
				<input checked="" type="checkbox"/>	Production Eng.				
				<input checked="" type="checkbox"/>	Purchasing				
				<input type="checkbox"/>	Q.A.				
				<input type="checkbox"/>	Service				
				<input checked="" type="checkbox"/>	Test				
<input type="checkbox"/>	Continued on Supplement Page		<input type="checkbox"/>	Drawing(s) attached					
Part Number	Description	Parts Added		Parts Deleted					
		Qty	Ref. Designator	Qty	Ref. Designator				
060-1002-0	1K, 1/8W, MF	1	R80						
060-4752-0	4.75K, 1/8W, MF	1	R74						
060-1213-0	12.1K, 1/8W, MF	2	R67, 34A						
060-3012-0	3.01K, 1/8W, MF	1	R70						
060-2002-0	2.00K, 1/8W, MF	1	R36						
032-4222-0	.0022uF/100V	2	C42, 44						
034-4101-0	100pF/100V	1	C39						
032-4104-0	.1uF/100V	1	C12						
032-4103-0	.01uF/100V	1	C14A						
020-1000-0	1N4148			1	D15				
060-1503-0	15K, 1/8W			1	R74				
060-4753-0	47.5K, 1/8W			1	R67				
060-1213-0	12.1K, 1/8W, MF			1	R70				
060-4992-0	4.99K, 1/8W			1	R36				
034-4470-0	47pF/100V			1	C39				
032-4472-0	.0047uF/100V			1	C42				
020-0120-0	1N759A			2	D11, 12				
032-4683-0	.068uF/100V			1	C12				

REVISION RECORD			
LTR	ECO NO:	APPROVED:	DATE:

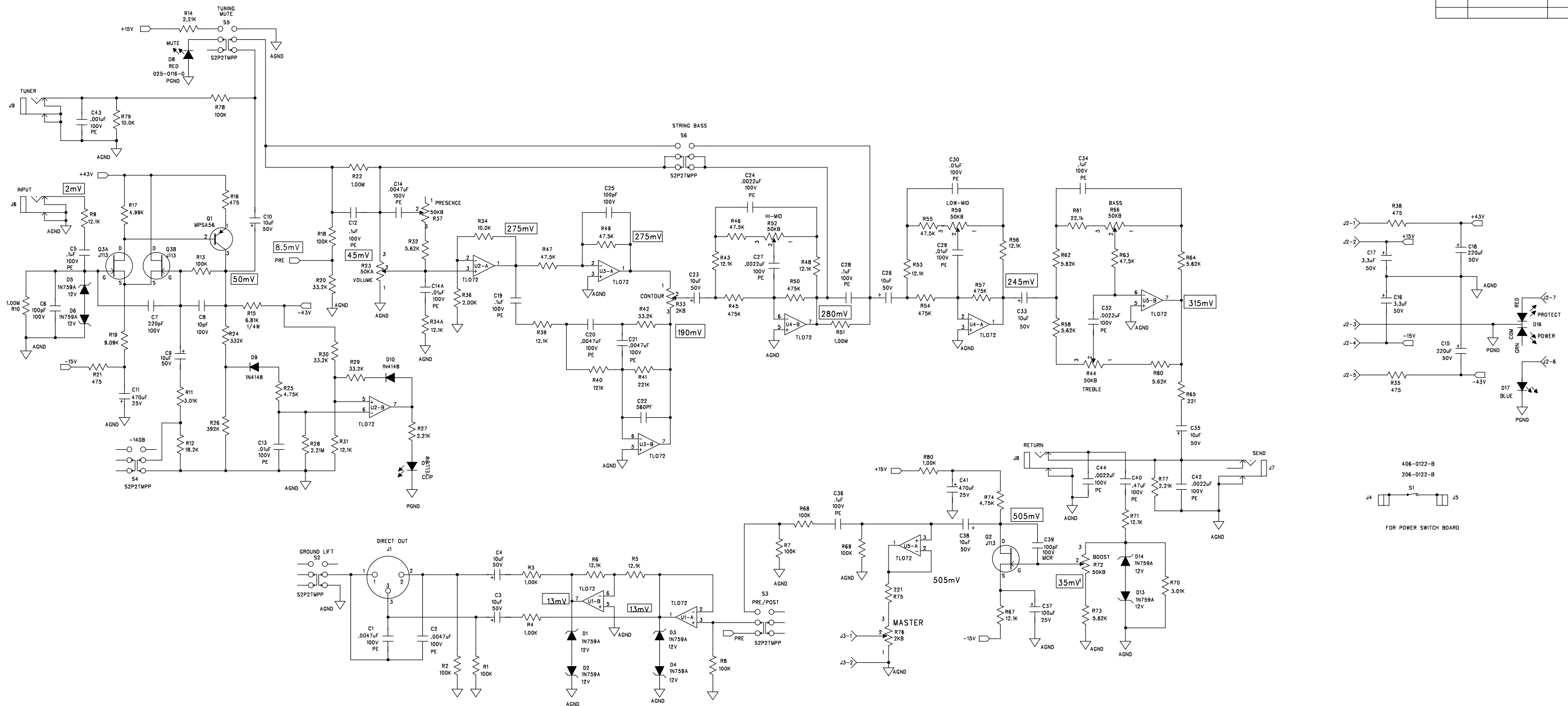

TEST CONDITIONS:
 1. All test point voltages are in RMS, with 200 Hz, 2 mV (-53.9 dBV) sine wave input.
 2. CONTOUR and PRESENCE on zero (off).
 Switches out, all tones, boost and volume on 10

MH125NP X1

NOT VALID UNLESS STAMP IS RED

gallien technology

2234 INDUSTRIAL DRIVE
 STOCKTON CA, 95206
 VOICE: 209-234-7300
 FAX: 209-234-8420

TITL: 400RB-IV PREAMP		REV: A1
DESIGNED: R.A.G. 5/19/99	DRAWING NO: 406-0241-A1	PART NO: 206-0241-A1
DRAWN: R.A.G. 8/05/03	FILE: B	
COMPANY: GALLIEN-KRUEGER		FILENAME: 6241A1

- CHANGE BOARD # FROM 0241-A TO 0241-A1.
- REPLACE D15 WITH R80-1K.
- CHANGE R74-4.75K, R67-12.1K, C39-100pF.
- CHANGE R70-3.0K, R36 TO 2.00K.
- CHANGE C42 TO .0022uF, C12 TO .1uF.
- ADD C44-.0022uF.
- REPLACE D11 WITH C14A-.01uF.
- REPLACE D12 WITH R34A-12.1K.

GALLIEN-KRUEGER

400RB-IV Preamp 206-0241-A1

Part No.	Reference	Description	Manufacturer	Mfr. Part No.
001-1030-1	U1-5	TLO72CP, LOW NOISE JFET OPAMP	MOTOROLA	TL072CP
010-1013-0	Q1	MPSA56 PNP 80V 500MA TO-92	MOTOROLA	MPS-A56
010-2010-0	Q2 Q3A Q3B	J113,N-JFET,35V,2MA,TO-92	NATIONAL	J113
020-0120-0	D1-6 D13-14	1N759A, ZENER,12V,5%,400MW, DO-35	MOTOROLA	1N759A
020-1000-0	D9-10	1N4148, RECT-FAST, 200MA, 100V	MOTOROLA	1N4148
025-0012-0	D16	LED,RED/GRN,5MM,630NM/560NM,	STANLEY	VRPG5614S
025-0023-0	D7	LED,YELLOW, 3MM, 585NM, 5MCD, 10MA	EVERLIGHT	EL204YD
025-0030-2	D17	LED,BLUE, 10MA	LITEON	LTL-42B6
025-0116-0	D8	LED,RED, 3MM, 635NM, 6MCD, 10MA,	EVERLIGHT	EL2041D
031-1107-0	C37	CAP,ELEC,RAD,107,20%,25V	UNITED CHEMI-CON	SMG25VB101M6X11LL
031-1477-0	C11 C41	CAP, ELEC, RAD, 470uF, 20%, 25V	UNITED CHEMI-CON	SMG25VB471M10X12LL
031-2106-0	C3,4,9,10,23,26,33	CAP,ELEC,RAD, 106, 20%, 50V	UNITED CHEMI-CON	SMG50VB10RM5X11LL
	C35 C38			
031-2227-0	C15 C18	CAP, ELEC, 220uF, 20%, 50V	UNITED CHEMI-CON	SMG50VB221M10X12LL
031-2335-0	C16-17	CAP,ELEC,RAD,335,20%,50V	UNITED CHEMI-CON	SMG50VB3R3M5X11LL
032-4102-0	C43	CAP,PE,102,5%,100V,	PANASONIC	ECQB1102JF
032-4103-0	C13 C29-30 C14A	CAP,PE,103,5%,100V,	PANASONIC	ECQV1103JM
032-4104-0	C5,12,19,28,34,36	CAP,PE,104,5%,100V,	PANASONIC	ECQV1104JM
032-4222-0	C24 C27 C32 C42 C44	CAP,PE,222,5%,100V,	PANASONIC	ECQB1222JF
032-4472-0	C1-2 C14 C20-21	CAP,PE,472,5%,100V,	PANASONIC	ECQB1472JF
032-4474-0	C40	CAP,PE,474,5%,100V,	PANASONIC	ECQV1474JM
034-4100-0	C8	CAP, MCR,10pF,5%,100V,NPO	TAITRON	TMRS100J100NPOB
034-4101-0	C6 C25 C39	CAP,MCR,100pF,5%,100V,	TAITRON	TMRS101J100NPOB
034-4221-0	C7	CAP,MCR,220pF,5%,100V,	TAITRON	TMRS221J100NPOB
034-4561-0	C22	CAP,MCR,560pF,5%,100V,	TAITRON	TMRS561J100NPOB
052-6812-0	R15	RES, METAL FILM, 6.81K, 1/4W, 1%	ECI	M2F1AK006.81
060-1002-0	R3-4 R80	RES,METAL FILM, 1.00K, 1/8W, 1%	ECI	M1F1AK001.00
060-1003-0	R34 R79	RES,METAL FILM, 10.0K, 1/8W,1%	ECI	M1F1AK010.00
060-1004-0	R1-2 R7-8 R13 R18	RES,METAL FILM, 100K, 1/8W, 1%	ECI	M1F1AK100.00
	R68-69 R78			
060-1005-0	R10 R22 R51	RES, MF, 1.00M, 1%,1/8W,	ECI	M1F1AM001.00
060-1213-0	R5,6,9,31,39,43,48,53	RES,METAL FILM, 12.1K, 1/8W, 1%	ECI	M1F1AK012.10
	R56,71,34A			
060-1213-0	R67	RES,METAL FILM, 12.1K, 1/8W, 1%	ECI	M1F1AK012.10
060-1214-0	R40	RES,METAL FILM, 121K, 1/8W, 1%	ECI	M1F1AK121.00
060-1823-0	R12	RES,METAL FILM, 18.2K, 1/8W, 1%	ECI	M1F1AK018.20
060-2002-0	R36	RES,METAL FILM, 2.00K, 1/8W, 1%	ECI	M1F1AK002.00
060-2211-0	R65 R75	RES,METAL FILM, 221 ohm, 1/8W, 1%	ECI	M1F1AJ221.00
060-2212-0	R14 R27 R77	RES,METAL FILM, 2.21K, 1/8W, 1%	ECI	M1F1AK002.21
060-2213-0	R61	RES,METAL FILM, 22.1K, 1/8W, 1%	ECI	M1F1AK022.10
060-2214-0	R41	RES,METAL FILM, 221K, 1/8W, 1%	ECI	M1F1AK221.00
060-2215-0	R28	RES, METAL FILM, 2.21M, 1/8W, 1%	ECI	M1F1AM002.21
060-3012-0	R11 R70	RES,METAL FILM, 3.01K, 1/8W, 1%	ECI	M1F1AK003.01
060-3323-0	R20 R29-30 R42	RES,METAL FILM, 33.2K, 1/8W, 1%	ECI	M1F1AK033.20
060-3324-0	R24	RES,METAL FILM, 332K, 1/8W, 1%	ECI	M1F1AK332.00
060-3924-0	R26	RES,METAL FILM, 392K, 1/8W, 1%	ECI	M1F1AK392.00
060-4751-0	R16 R21 R35 R38	RES,METAL FILM, 475 ohm, 1/8W, 1%	ECI	M1F1AJ475.00
060-4752-0	R25 R74	RES,METAL FILM, 4.75K, 1/8W, 1%	ECI	M1F1AK004.75
060-4753-0	R46-47 R49 R55 R63	RES,METAL FILM, 47.5K, 1/8W, 1%	ECI	M1F1AK047.50
060-4754-0	R45 R50 R54 R57	RES,METAL FILM, 475K, 1/8W, 1%	ECI	M1F1AK475.00
060-4992-0	R17	RES,METAL FILM, 4.99K, 1/8W, 1%	ECI	M1F1AK004.99
060-5622-0	R32,58,60,62,64,73	RES,METAL FILM, 5.62K, 1/8W, 1%	ECI	M1F1AK005.62
060-9092-0	R19	RES,METAL FILM, 9.09K, 1/8W, 1%	ECI	M1F1AK009.09
070-1513-0	R23	POT,50K-15A,7MM,KNURL.,1W	SONG HUEI	16K1-A50K-L15KC
070-1514-0	R37,44,52,59,66,72	POT,50KB,7MM,KNURL.,1W	SONG HUEI	16K1-B50K-L15KC
070-1522-0	R33 R76	POT,2KB,7MM,KNURL.,1W	SONG HUEI	16K1-B2K-L15KC
090-0007-0	S1	SWITCH, 8A/128A,250V,PP,PCB	TECX	KDC-A04-10-B, B2-F
090-0012-0	S2-6	SWITCH,MIMI PP,DPDT.,1A BRK/MAKE,	ELKECTRONIC COMP	MTH2UEE-1D911
092-0066-0	J4-5	FASTON, M, PC, .250"	KEYSTONE	1021
092-0081-0	J6-9	JACK,1/4",MONO,PC,NON GROUNDING	NEUTRIK	S102-84
092-0084-0	J1	CON,XLR,MALE,PC,PL, SCREW MNT	NEUTRIK	X906-05
093-0051-0	J3	HDR, 2MMX2, VERT, LOCK	JST	B2B-PH-K-S
093-2005-0	J2	HDR, 2MMX7, VERT, SHROUDED	JST	B7B-PH-K-S
145-0241-A		400RB-IV PREAMP RAW BOARD		

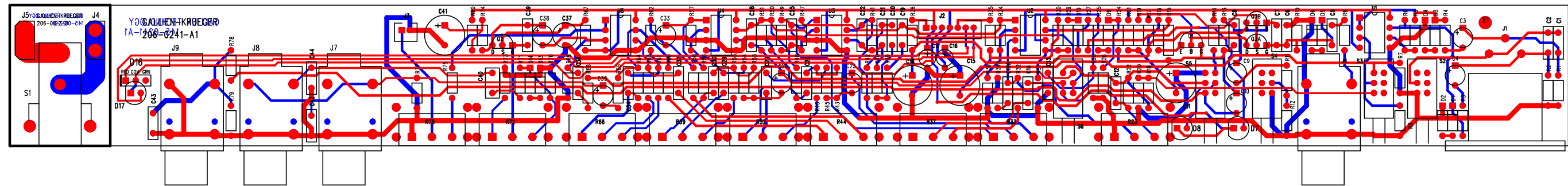

PCB WORK INSTRUCTIONS

DWG #420-0241-A1

NOTES:

UNLESS OTHERWISE SPECIFIED:

1. SQUARE PADS ON THRU HOLE PARTS (ie: CONNECTORS, DIPS, SIPS, LEDS) DENOTE PIN 1.
2. ALL BOARDS REQUIRE A COMPLETE AND THOROUGH VISUAL INSPECTION.
3. ALL BOARDS MUST BE BARE BOARD TESTED.
4. ASSEMBLE AND SOLDER PER ANSI/IPC-A-610B.

LOADING

5. CLIP BUSHING TABS OFF ON POTS R23, 33, 37, 44, 52, 59, 66, 72, 76
6. SEE DETAIL A FOR MOUNTING D7 AND 8
7. SEE DETAIL "B" FOR MOUNTING D16 AND D17

FINAL QA

8. CHECK TO SEE ALL POTS, JACKS, AND SWITCHES ARE MOUNTED FLUSH AND STRAIGHT

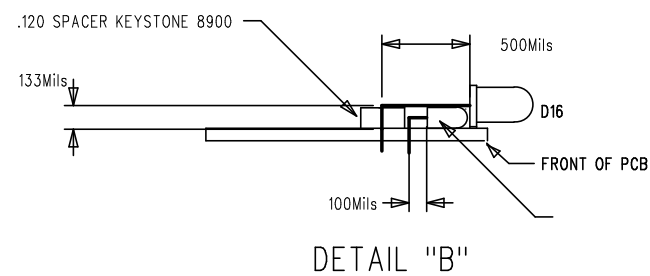
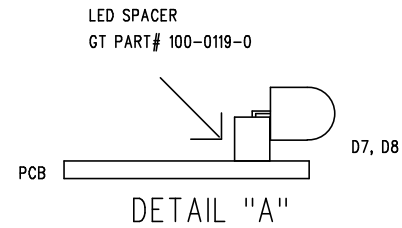

NOT VALID UNLESS STAMP IS RED		gallien technology		2234 INDUSTRIAL DRIVE STOCKTON CA, 95206 VOICE: 209-234-7300 FAX: 209-234-8420	
APPROVALS		TITLE: 400RB-IV PRE-AMP BD			
INIT	DATE	SIZE	DRAWING NO:	REV.	
DESIGNED: R.A.G.	1/6/98	B	405-0241-A1	A1	
DRAWN: R.A.G.	8/06/03		PART NO:		
ELEC:			145-0241-A1		
LAYER DESCRIPTION:		COMPANY:			
TOP SIDE ROUTING		GERBER FILE NAME: 5241A1			
		FILENAME: 5241A1			

REVISION RECORD			
LTR	ECO NO:	APPROVED:	DATE:

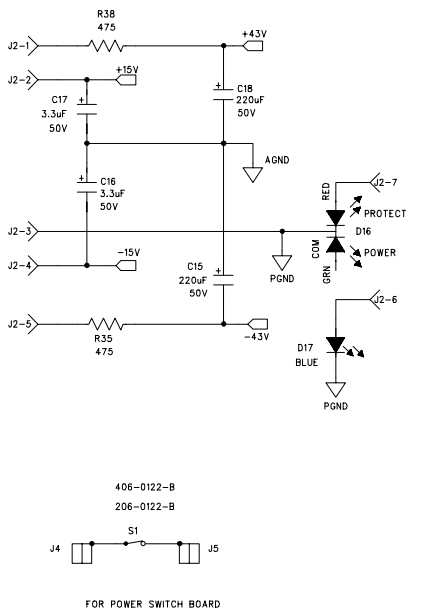
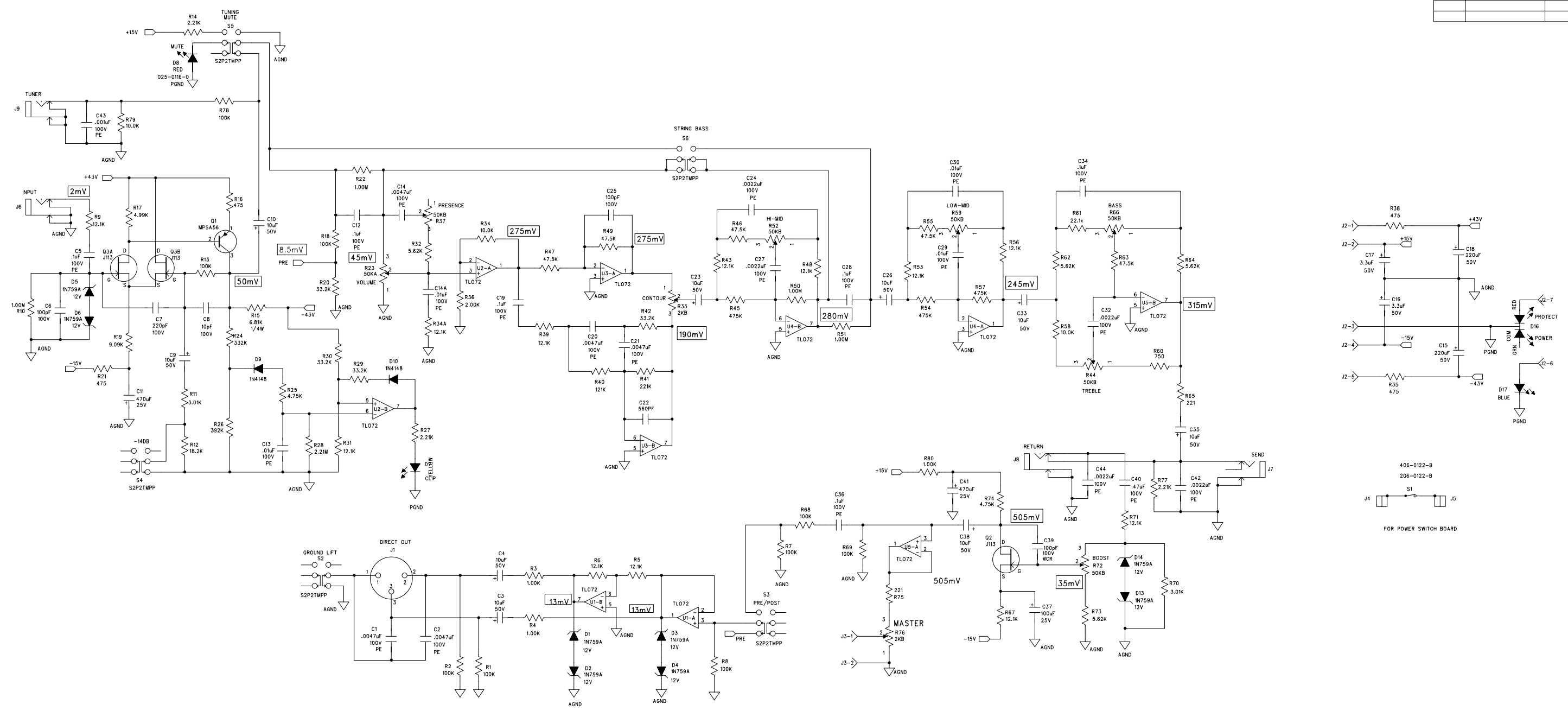

TEST CONDITIONS:
 1. All test point voltages are in RMS, with 200 Hz, 2 mV (-53.9 dBV) sine wave input.
 2. CONTOUR and PRESENCE on zero (off).
 Switches out, all tones, boost and volume on 10



NOT VALID UNLESS STAMP IS RED

gallien technology

2234 INDUSTRIAL DRIVE
 STOCKTON CA, 95206
 VOICE: 209-234-7300
 FAX: 209-234-8420

REV A2: PREAMP REVISED.	APPROVALS	TITLE:	400RB-IV PREAMP
1. CHANGE BOARD # FROM 0241-A1 TO 0241-A2.	INIT	DATE	DESIGNED: R.A.G. 5/19/99
2. CHANGE R50 TO 1M FROM 475K.	DRAWN: Noli	DATE	8/16/04
3. CHANGE R58 TO 10K FROM 5.62K.	MECH:	COMPANY:	GALLIEN-KRUEGER
4. CHANGE R60 TO 750 FROM 5.62K.	Q/A:	FILENAME:	6241A2
	RELEASED:		

D

C

B

A

D

C

B

A

GALLIEN-KRUEGER

400RB-IV Preamp		Bill Of Materia	206-0241-A2		
Part No.	Reference	Description	Manufacturer	Mfr. Part No.	Quan
032-4102-0	C43	CAP,PE,102,5%,100V,	PANASONIC	ECQB1102JF	1
032-4222-0	C24 C27 C32 C42 C44	CAP,PE,222,5%,100V,	PANASONIC	ECQB1222JF	5
032-4472-0	C1-2 C14 C20-21	CAP,PE,472,5%,100V,	PANASONIC	ECQB1472JF	5
032-4103-0	C13 C29-30 C14A	CAP,PE,103,5%,100V,	PANASONIC	ECQV1103JM	4
032-4104-0	C5 C12 C19 C28 C34 C36	CAP,PE,104,5%,100V,	PANASONIC	ECQV1104JM	6
032-4474-0	C40	CAP,PE,474,5%,100V,	PANASONIC	ECQV1474JM	1
034-4101-0	C6 C25 C39	CAP,MCR,100pF,5%,100V,	TAITRON	TMRS101J100NPOB	3
031-1107-0	C37	CAP,ELEC,RAD,107,20%,25V	UNITED CHEMI-CON	SMG25VB101M6X11LL	1
034-4100-0	C8	CAP, MCR,10pF,5%,100V,NPO	TAITRON	TMRS100J100NPOB	1
031-2106-0	C3-4 C9-10 C23 C26 C33 C35 C38	CAP,ELEC,RAD, 106, 20%, 50V	UNITED CHEMI-CON	SMG50VB10RM5X11LL	9
034-4221-0	C7	CAP,MCR,220pF,5%,100V,	TAITRON	TMRS221J100NPOB	1
031-2227-0	C15 C18	CAP, ELEC, 220uF, 20%, 50V	UNITED CHEMI-CON	SMG50VB221M10X12LL	2
031-2335-0	C16-17	CAP,ELEC,RAD,335,20%,50V	UNITED CHEMI-CON	SMG50VB3R3M5X11LL	2
031-1477-0	C11 C41	CAP, ELEC, RAD, 470uF, 20%, 25V	UNITED CHEMI-CON	SMG25VB471M10X12LL	2
034-4561-0	C22	CAP,MCR,560pF,5%,100V,	TAITRON	TMRS561J100NPOB	1
092-0081-0	J6-9	JACK,1/4",MONO,PC,NON GROUNDING	NEUTRIK	S102-84	4
092-0066-0	J4-5	FASTON, M, PC, .250"	KEYSTONE		1021 2
092-0084-0	J1	CON,XLR,MALE,PC,PL, SCREW MNT	NEUTRIK	X906-05	1
020-1000-0	D9-10	1N4148, RECT-FAST, 200MA, 100V	MOTOROLA	1N4148	2
020-0120-0	D1-6 D13-14	1N759A, ZENER,12V,5%,400MW, DO-35	MOTOROLA	1N759A	8
093-0051-0	J3	HDR, 2MMX2, VERT, LOCK	JST	B2B-PH-K-S	1
093-2005-0	J2	HDR, 2MMX7, VERT, SHROUDED	JST	B7B-PH-K-S	1
001-1030-1	U1-5	TLO72CP, LOW NOISE JFET OPAMP	MOTOROLA	TL072CP	5
025-0030-2	D17	LED,BLUE, 10MA	LITEON	LTL-42B6	1
025-0012-0	D16	LED,RED/GRN,5MM,630NM/560NM,15MCD/15MCD	STANLEY	VRPG5614S	1
025-0116-0	D8	LED,RED, 3MM, 635NM, 6MCD, 10MA, 40DEG	EVERLIGHT	EL2041D	1
025-0023-0	D7	LED,YELLOW, 3MM, 585NM, 5MCD, 10MA	EVERLIGHT	EL204YD	1
000-0000-0	X1	.125 HOLE, NON-PLATED			1
070-1522-0	R33 R76	POT,2KB,7MM,KNURL,.1W	SONG HUEI	16K1-B2K-L15KC	2
070-1513-0	R23	POT,50K-15A,7MM,KNURL,.1W	SONG HUEI	16K1-A50K-L15KC	1
070-1514-0	R37 R44 R52 R59 R66 R72	POT,50KB,7MM,KNURL,.1W	SONG HUEI	16K1-B50K-L15KC	6
060-1002-0	R3-4 R80	RES,METAL FILM, 1.00K, 1/8W, 1%	ECI	M1F1AK001.00	3
060-1005-0	R10 R22 R51	RES, MF, 1.00M, 1%,1/8W, 060-1005-0	ECI	M1F1AM001.00	3
060-1005-0	R50	RES, METAL FILM, 1.00M, 1/8W, 1%	ECI	M1F1AK475.00	1
060-1003-0	R34 R79	RES,METAL FILM, 10.0K, 1/8W,1%	ECI	M1F1AK010.00	2
060-1003-0	R58	RES,METAL FILM, 10.0K, 1/8W,1%	ECI	M1F1AK005.62	1
060-1004-0	R1-2 R7-8 R13 R18 R68-69 R	78 RES,METAL FILM, 100K, 1/8W, 1%	ECI	M1F1AK100.00	9
060-1213-0	R5-6 R9 R31 R39 R43 R48 R5 R56 R71 R34A	3 RES,METAL FILM, 12.1K OHM, 1/8W, 1%	ECI	M1F1AK012.10	11
060-1213-0	R67	RES,METAL FILM, 12.1K, 1/8W, 1%	ECI	M1F1AK012.10	1
060-1214-0	R40	RES,METAL FILM, 121K, 1/8W, 1%	ECI	M1F1AK121.00	1
060-1823-0	R12	RES,METAL FILM, 18.2K, 1/8W, 1%	ECI	M1F1AK018.20	1
060-2002-0	R36	RES,METAL FILM, 2.00K, 1/8W, 1%	ECI	M1F1AK002.00	1
060-2212-0	R14 R27 R77	RES,METAL FILM, 2.21K, 1/8W, 1%	ECI	M1F1AK002.21	3
060-2215-0	R28	RES, METAL FILM, 2.21M, 1/8W, 1%	ECI	M1F1AM002.21	1
060-2213-0	R61	RES,METAL FILM, 22.1K, 1/8W, 1%	ECI	M1F1AK022.10	1
060-2214-0	R41	RES,METAL FILM, 221K, 1/8W, 1%	ECI	M1F1AK221.00	1
060-2211-0	R65 R75	RES,METAL FILM, 221 ohm, 1/8W, 1%	ECI	M1F1AJ221.00	2
060-3012-0	R11 R70	RES,METAL FILM, 3.01K, 1/8W, 1%	ECI	M1F1AK003.01	2
060-3323-0	R20 R29-30 R42	RES,METAL FILM, 33.2K, 1/8W, 1%	ECI	M1F1AK033.20	4
060-3324-0	R24	RES,METAL FILM, 332K, 1/8W, 1%	ECI	M1F1AK332.00	1
060-3924-0	R26	RES,METAL FILM, 392K, 1/8W, 1%	ECI	M1F1AK392.00	1
060-4752-0	R25 R74	RES,METAL FILM, 4.75K, 1/8W, 1%	ECI	M1F1AK004.75	2
060-4992-0	R17	RES,METAL FILM, 4.99K, 1/8W, 1%	ECI	M1F1AK004.99	1
060-4753-0	R46-47 R49 R55 R63	RES,METAL FILM, 47.5K, 1/8W, 1%	ECI	M1F1AK047.50	5
060-4754-0	R45 R54 R57	RES,METAL FILM, 475K, 1/8W, 1%	ECI	M1F1AK475.00	3
060-4751-0	R16 R21 R35 R38	RES,METAL FILM, 475 ohm, 1/8W, 1%	ECI	M1F1AJ475.00	4
060-5622-0	R32 R62 R64 R73	RES,METAL FILM, 5.62K, 1/8W, 1%	ECI	M1F1AK005.62	4
052-6812-0	R15	RES, METAL FILM, 6.81K OHM, 1/4W, 1%	ECI	M2F1AK006.81	1
060-7501-0	R60	RES,METAL FILM, 750, 1/8W, 1%	ECI	M1F1AK005.62	1
060-9092-0	R19	RES,METAL FILM, 9.09K, 1/8W,1%	ECI	M1F1AK009.09	1
090-0012-0	S2-6	SWITCH,MIMI PP,DPDT,.1A BRK/MAKE,PC TERM	ELKECTRONIC COMP	MTH2UEE-1D911	5
090-0007-0	S1	SWITCH, 8A/128A,250V,PP,PCB	TECX	KDC-A04-10-B, B2-F	1
010-2010-0	Q2 Q3A Q3B	J113,N-JFET,35V,2MA,TO-92	NATIONAL	J113	3
010-1013-0	Q1	MPSA56 PNP 80V 500MA TO-92	MOTOROLA	MPS-A56	1
145-0241-A		400RB-IV PREAMP RAW BOARD			1.00

Customer Name:	Gallien-Krueger	Current Rev #:	A1	New ECO Rev #:	A2
Model:	400RB-IV	Distribute To:		Page:	1
Assembly Description:	Preamp	Originator:	Enrique Hernandez		
Assembly Numbers:	206-0241-A	Approved by:			
		Effective Date:	8/2/2004		

Effective		Document Update		Date	Initials
<input checked="" type="checkbox"/>	All in Process	<input checked="" type="checkbox"/>	Next Buy		
<input type="checkbox"/>	All in Service	<input type="checkbox"/>	Next Production Run		
<input type="checkbox"/>	All in Stock	<input type="checkbox"/>			
Beginning Serial Number:		<input checked="" type="checkbox"/>	BOM		Noli

Reason For Change		Document Update		Date	Initials
Re-voicing of the Pre-Amp:		<input type="checkbox"/>	Artwork		
Resistors R50, R58, and R60 were replaced with different value resistors, as listed below, to reduce brightness, and increase low end bass efficiency of the amplifier.		<input type="checkbox"/>	Assembly Dwg.		
		<input type="checkbox"/>	Board Artwork		
		<input type="checkbox"/>	Control Form		
		<input type="checkbox"/>	Costing		
		<input type="checkbox"/>	Fab Drawing		
		<input type="checkbox"/>	Inspection Proc.		
		<input checked="" type="checkbox"/>	Part Master File		Noli
		<input checked="" type="checkbox"/>	Schematic	8/16/04	Noli
		<input type="checkbox"/>	Service Manual		
		<input checked="" type="checkbox"/>	Test Procedure		
		<input type="checkbox"/>			
		<input type="checkbox"/>			

		Other Affected Assemblies			
		302 and 303 Assemblies			
<input type="checkbox"/>	Continued on ECO Supplement Page				

Description Of Change		Distribution		Date	Initials
Update BOM.		<input type="checkbox"/>	Accounting		
		<input type="checkbox"/>	Assembly		
Update Part Master File.		<input type="checkbox"/>	Customer		
		<input checked="" type="checkbox"/>	Engineering		
		<input checked="" type="checkbox"/>	Incoming Q.C.		
		<input type="checkbox"/>	Planning		
		<input checked="" type="checkbox"/>	Production Eng.		
		<input checked="" type="checkbox"/>	Purchasing		
		<input type="checkbox"/>	Q.A.		
		<input type="checkbox"/>	Receiving		
		<input type="checkbox"/>	Service		
		<input checked="" type="checkbox"/>	Test		
		<input type="checkbox"/>	Vendor		
		<input type="checkbox"/>			
		<input type="checkbox"/>			

<input type="checkbox"/>	Continued on ECO Supplement Page		<input type="checkbox"/>	Drawing(s) attached	
--------------------------	----------------------------------	--	--------------------------	---------------------	--

Part Number	Description	Parts Added		Parts Deleted	
		Qty	Ref. Designator	Qty	Ref. Designator
060-4754-0	475K, 1/8W, MF			1	R50
060-5622-0	5.62K, 1/8W, MF			1	R58
060-5622-0	5.62K, 1/8W, MF			1	R60
060-1005-0	1M, 1/8W, MF	1	R50		
060-1003-0	10K, 1/8W, MF	1	R58		
060-7501-0	750 ohm, 1/8W, MF	1	R60		

ZONE	Dim.	ECO#	Rev.	REVISIONS		Date

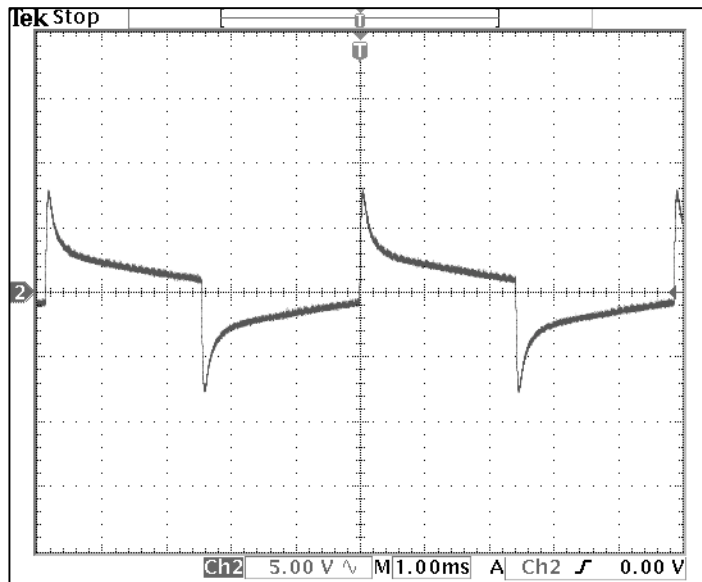

Figure 1
Tones center, Filters OFF

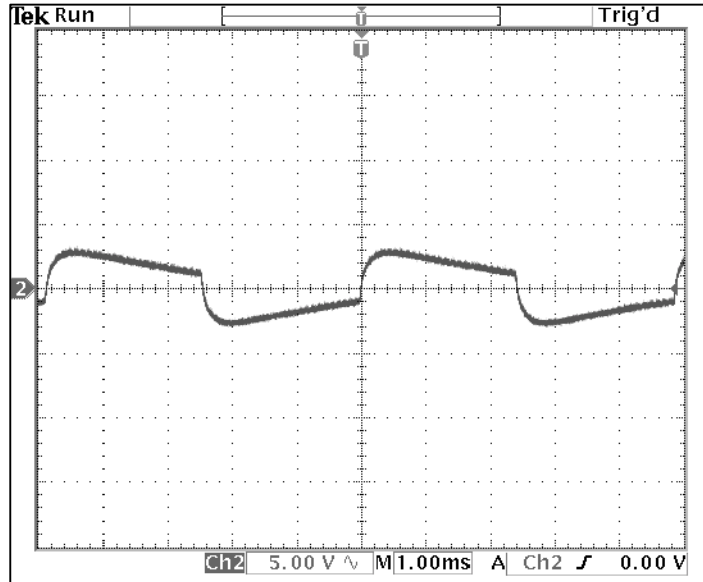

Figure 3
TREBLE to 0

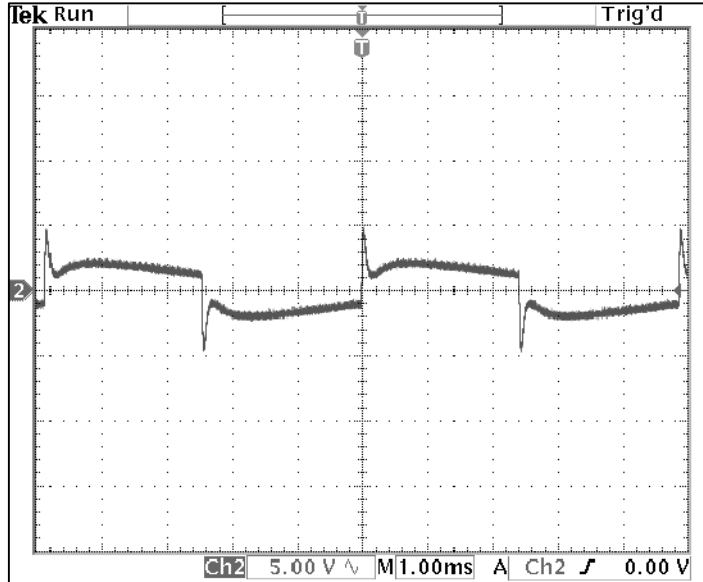

Figure 5
HI-MID to 0

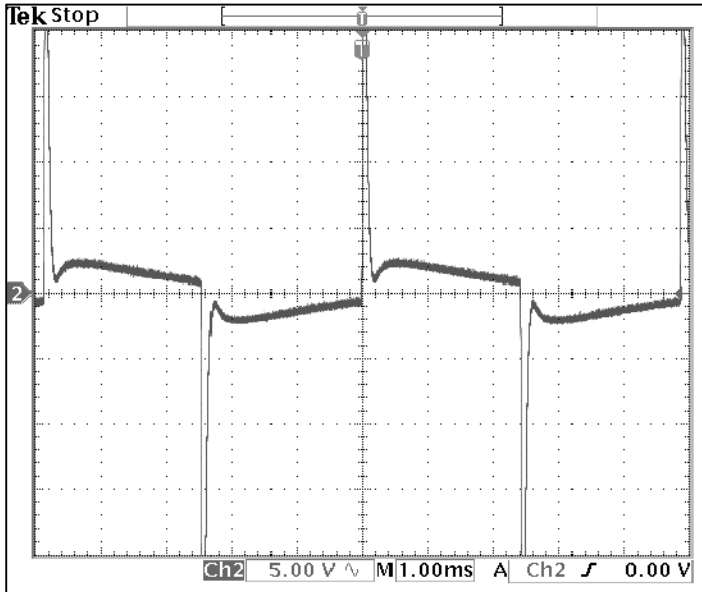

Figure 2
TREBLE to 10

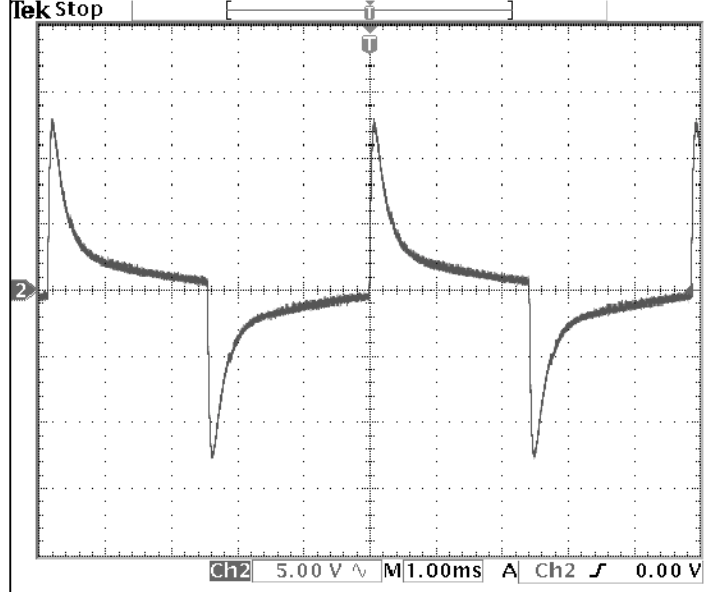

Figure 4
HI-MID to 10

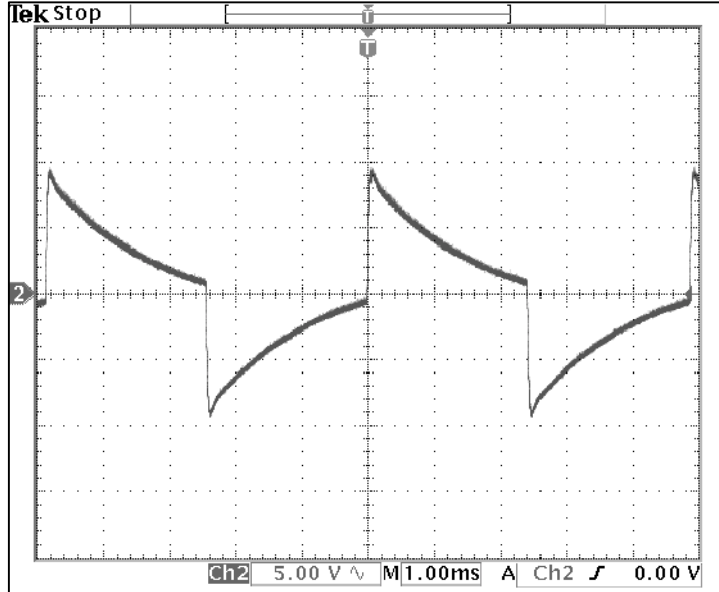

Figure 6
LO-MID to 10

Set up:

1. Apply signal into the input with 200Hz square wave @ -46dBV(5mVrms).
2. Set VOLUME, all ACTIVE EQ's, BOOST and MASTER to center(half way), CONTOUR and PRESENCE to 0.
3. Look at output with scope set on 1mS/div and 5V/div.

QTY PER ASSY	PART NUMBER	DESCRIPTION	DESIGNATION(S)	ITEM NO.
PROPRIETARY				
THIS DRAWING CONTAINS INFORMATION WHICH IS PROPRIETARY TO GALLIEN TECHNOLOGY CORPORATION. DO NOT REPRODUCE IN ANY FORM OR DISTRIBUTE IN ANY FASHION WITHOUT THE EXPRESS WRITTEN PERMISSION OF GALLIEN TECHNOLOGY CORPORATION.				
<small>TOLERANCES UNLESS OTHERWISE INDICATED DIMENSIONS SHOWN ARE IN INCHES</small> FRACTION ± ANGLES ± .XX ± 0.01 .XXX ± 0.005		gallien technology 2234 INDUSTRIAL DRIVE STOCKTON, CA 95206		
		TITLE: 400RB-IV PREAMP TEST WAVEFORMS		
<small>MATERIAL: (SEE NOTE 1)</small> <small>FINISH: (SEE NOTE 1)</small>		APPROVALS INIT DATE MECH. DESIGN: ATM 04/22/04 DRAWN BY: ATM PROJ. MGR.: Q/A: RELEASED:		SIZE B DRAWING NUMBER: PART NUMBER: 206-0241-A1 REVISION A1
		SCALE: NOT TO SCALE SHEET 1 OF 2		

ZONE	Dim.	ECO#	Rev.	REVISIONS		Date

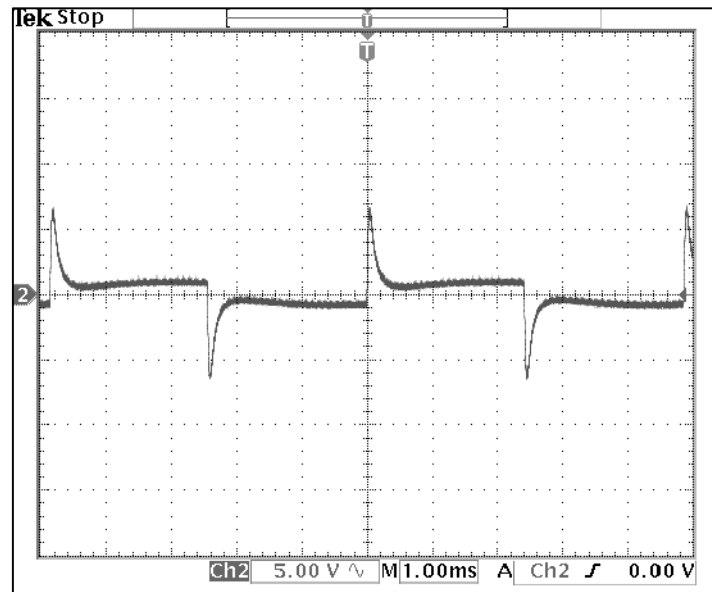

Figure 7
LO-MID to 0

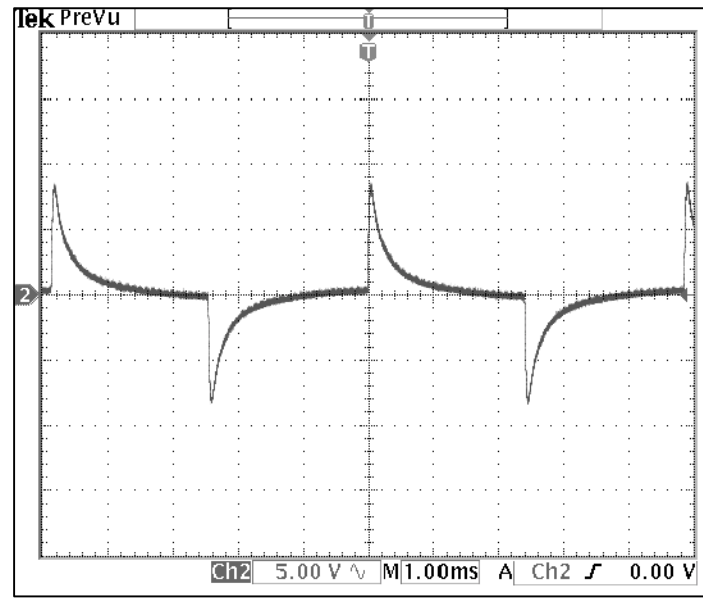

Figure 9
BASS to 0

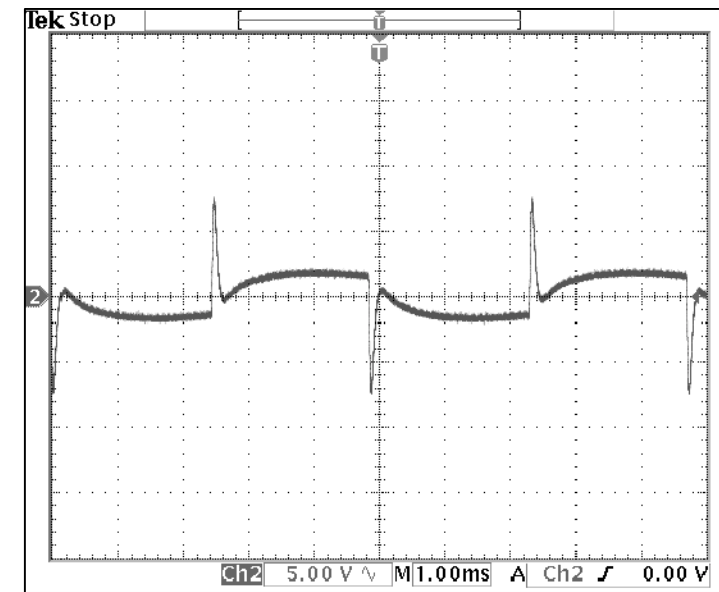

Figure 11
CONTOUR to 10

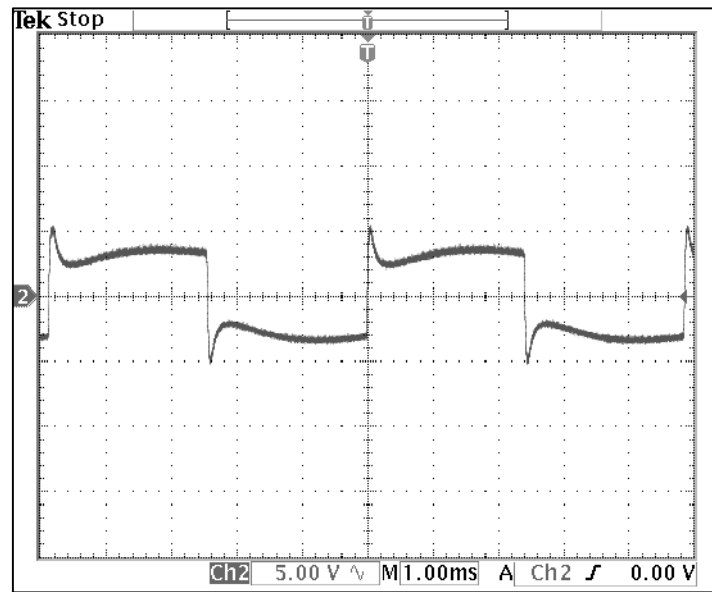

Figure 8
BASS to 10

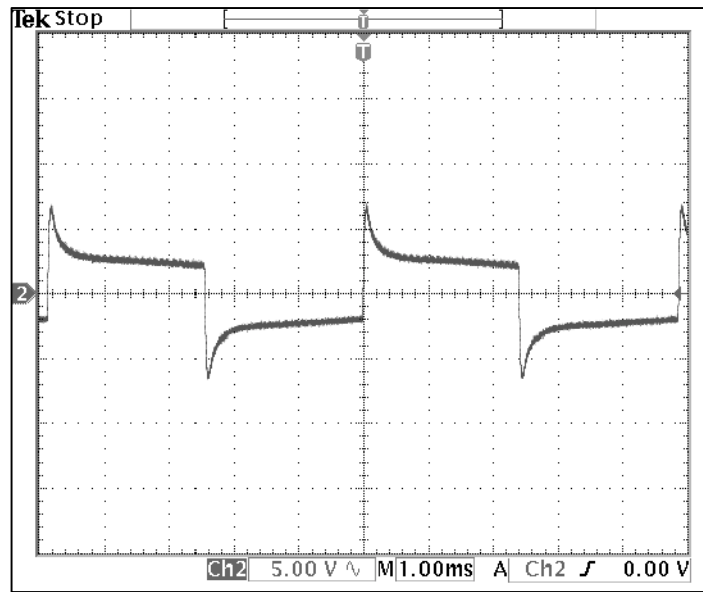

Figure 10
STRING BASS SWITCH IN

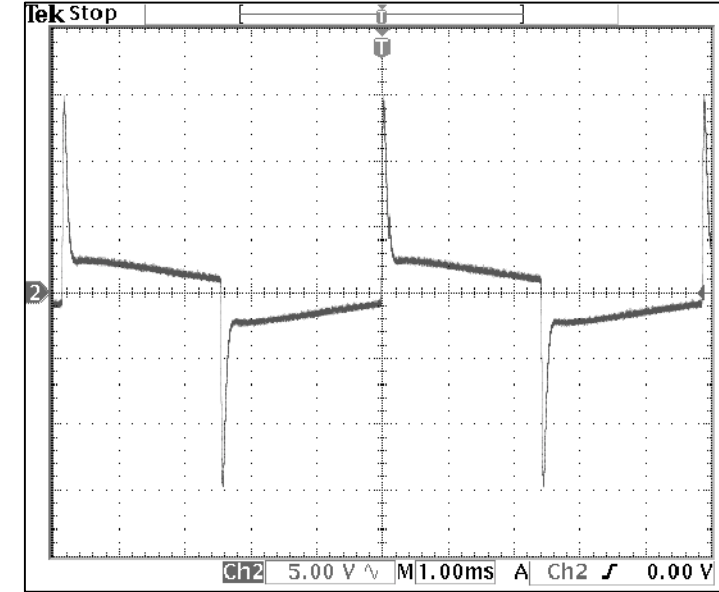

Figure 12
PRESENCE to 10

Set up:

1. Apply signal into the input with 200Hz square wave @ -46dBV(5mVrms).
2. Set VOLUME, all ACTIVE EQ's, BOOST and MASTER to center(half way), CONTOUR and PRESENCE to 0.
3. Look at output with scope set on 1mS/div and 5V/div.

QTY PER ASSY	PART NUMBER	DESCRIPTION	DESIGNATION(S)	ITEM NO.
PROPRIETARY				
THIS DRAWING CONTAINS INFORMATION WHICH IS PROPRIETARY TO GALLIEN TECHNOLOGY CORPORATION. DO NOT REPRODUCE IN ANY FORM OR DISTRIBUTE IN ANY FASHION WITHOUT THE EXPRESS WRITTEN PERMISSION OF GALLIEN TECHNOLOGY CORPORATION.				
<small>TOLERANCES UNLESS OTHERWISE INDICATED DIMENSIONS SHOWN ARE IN INCHES</small> FRACTION ± ANGLES ± .XX ± 0.01 .XXX ± 0.005		APPROVALS		
		INIT	DATE	
MATERIAL: (SEE NOTE 1)		MECH. DESIGN:	DRAWN BY: ATM 04/22/04	
FINISH: (SEE NOTE 1)		PROJ. MGR.:	Q/A:	
		RELEASED:		
gallien technology 2234 INDUSTRIAL DRIVE STOCKTON, CA 95206		TITLE: 400RB-IV		
		PREAMP TEST WAVEFORMS		
SIZE: B		DRAWING NUMBER:	REVISION: A1	
PART NUMBER: 206-0241-A1		FILENAME:		
SCALE: NOT TO SCALE		SHEET 2 OF 2		

A

B

C

D

E

F

ZONE	Dim.	ECO#	Rev.	REVISIONS		Date

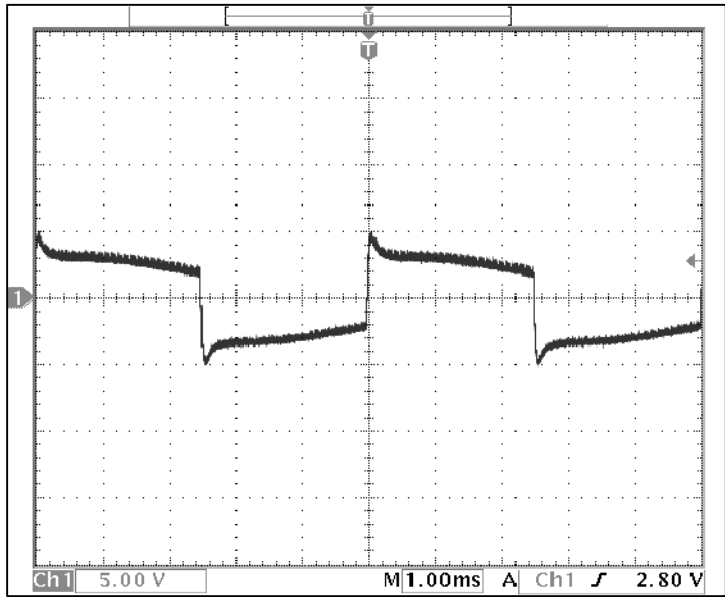

Figure 1
Tones center, Filters off

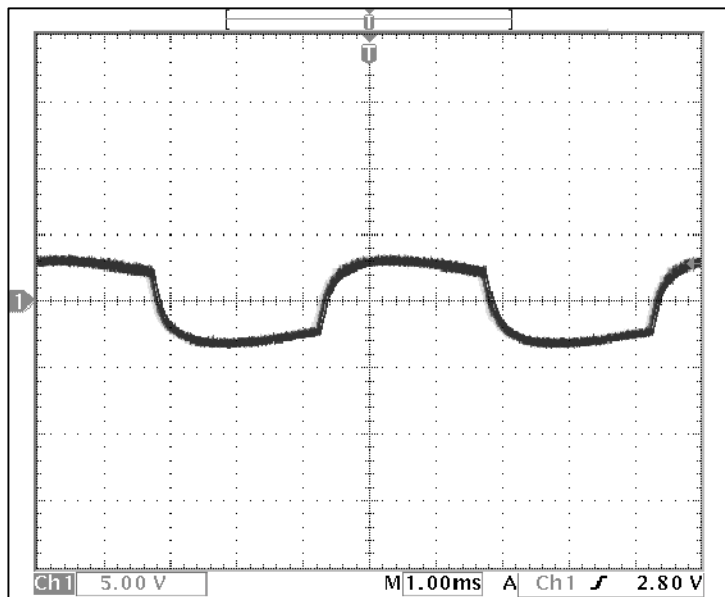

Figure 2
Treble to 0

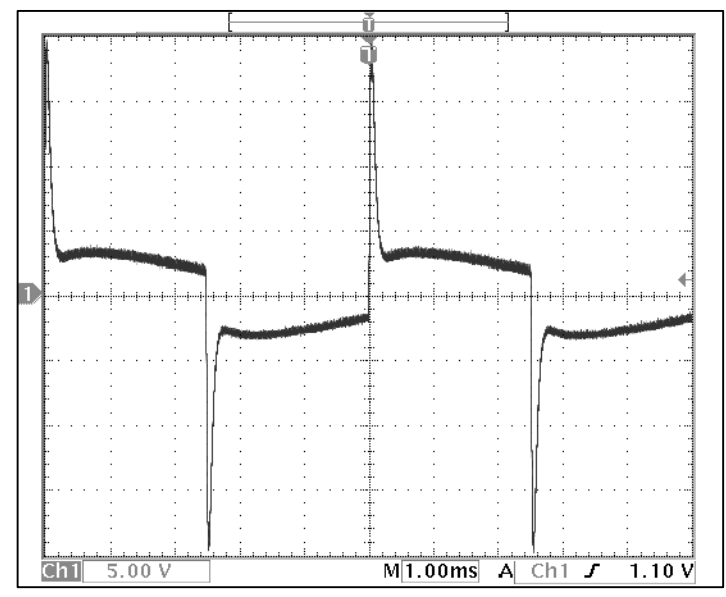

Figure 3
Treble to 10

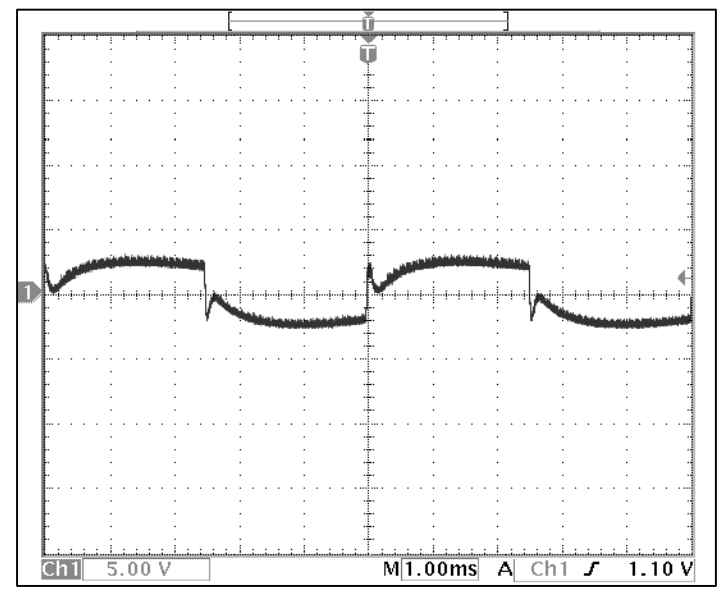

Figure 4
Hi-Mid to 0

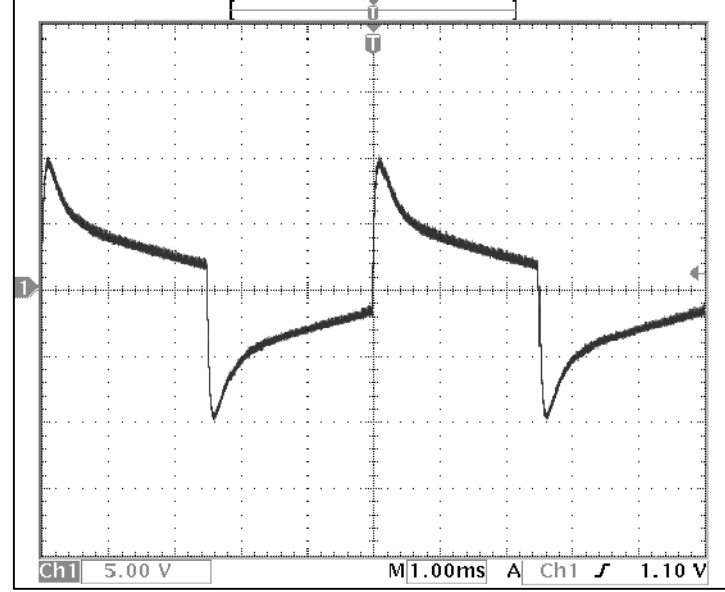

Figure 5
Hi-Mid to 10

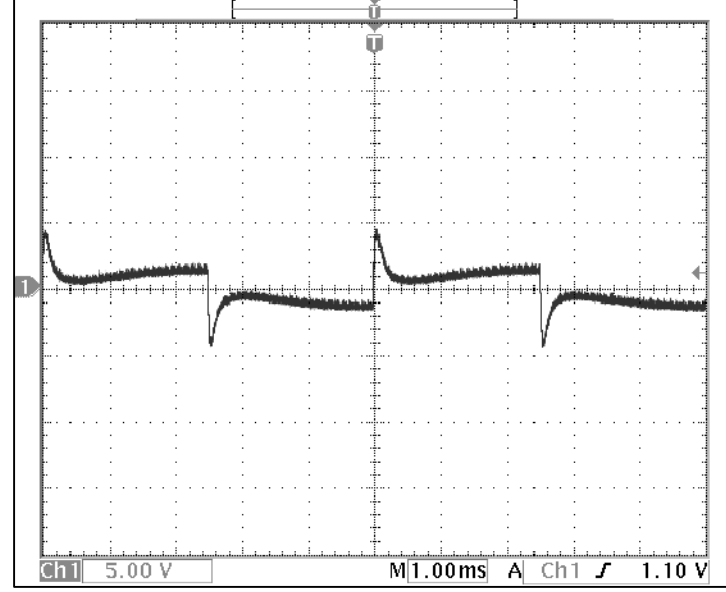

Figure 6
Lo-Mid to 0

1. Apply signal into the input with 200Hz square wave @ -46dBV(5mVrms).
2. Set Volume, all Active EQ's, Boost and Master to center(halfway), Contour and Presence to 0.
3. Look at output with scope set on 5V/div and 1ms/div.

HOLE REFERENCE CHART		
HOLE	DESCRIPTION	QTY.

QTY PER ASSY		PART NUMBER	
PROPRIETARY		PARTS LIST	
<small>THIS DRAWING CONTAINS INFORMATION WHICH IS PROPRIETARY TO GALLIEN TECHNOLOGY CORPORATION. DO NOT REPRODUCE IN ANY FORM OR DISTRIBUTE IN ANY FASHION WITHOUT THE EXPRESS WRITTEN PERMISSION OF GALLIEN TECHNOLOGY CORPORATION.</small>		gallien technology 2234 INDUSTRIAL DRIVE STOCKTON, CA 95206	
<small>UNLESS OTHERWISE INDICATED DIMENSIONS SHOWN ARE IN INCHES</small>		TITLE: 400RB-IV	
APPROVALS		SIZE: B DRAWING NUMBER: 206-0241-A2 REVISION: A2	
TOLERANCES FRACTION ± ANGLES ± .XX ± 0.01 .XXX ± 0.005	INIT MECH. DESIGN: DRAWN BY: EAH ELEC: PROJ. MGR.: Q/A: RELEASED:	DATE 8/19/04	FILENAME: SCALE: NOT TO SCALE SHEET 1 OF 2

A

B

C

D

E

F

A

B

C

D

E

F

ZONE	Dim.	ECO#	Rev.	REVISIONS	Date

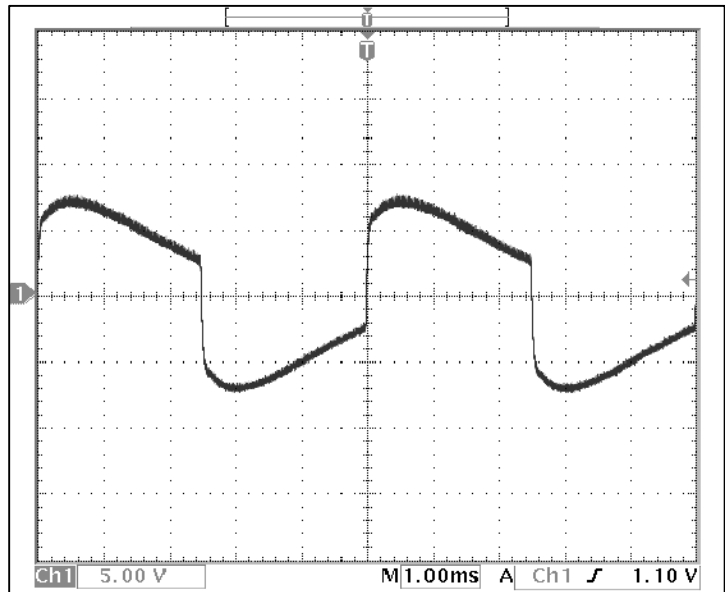

Figure 7
Lo-Mid to 10

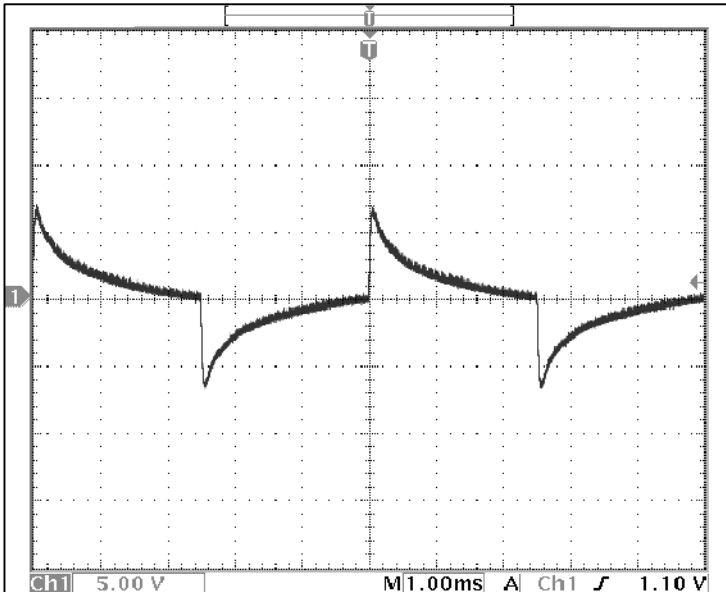

Figure 8
Bass to 0

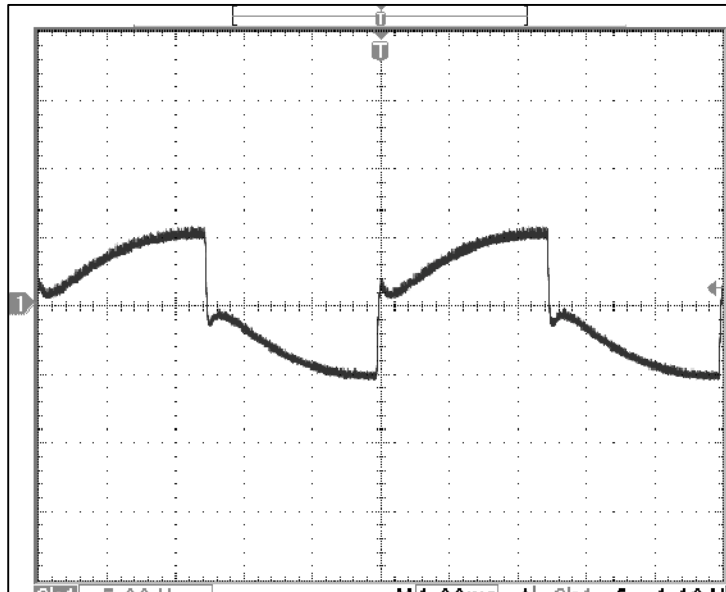

Figure 9
Bass to 10

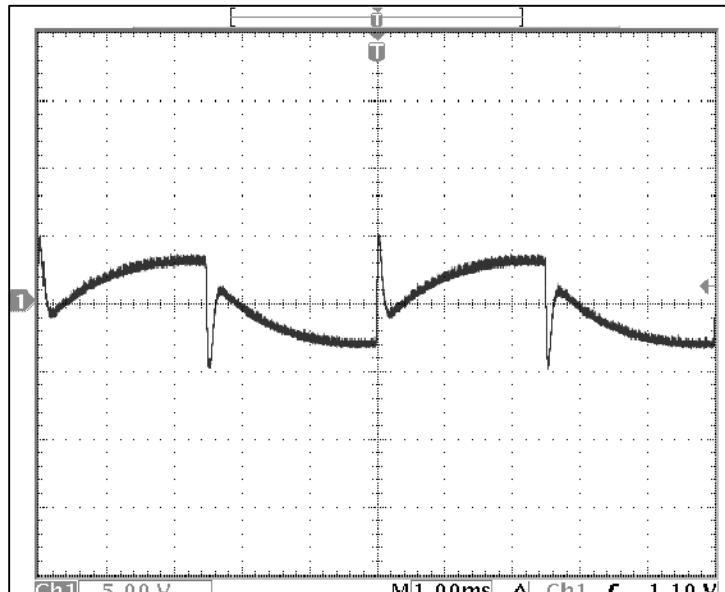

Figure 10
Contour to 10

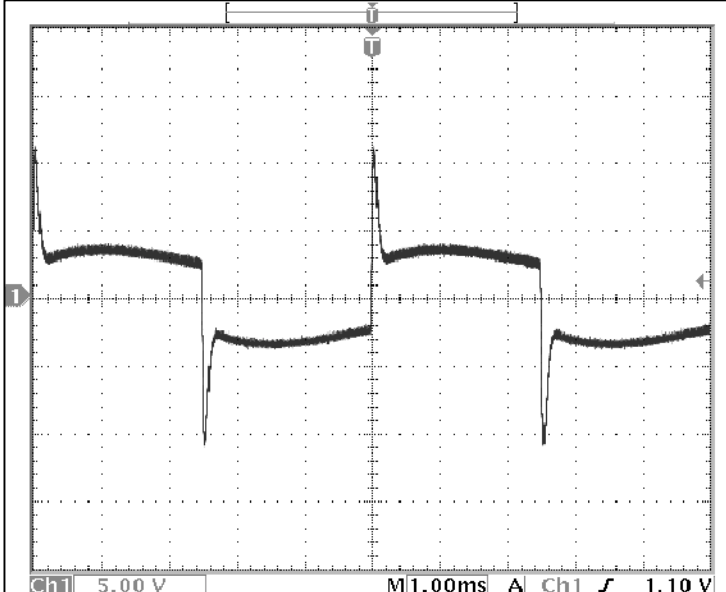

Figure 11
Presence to 10

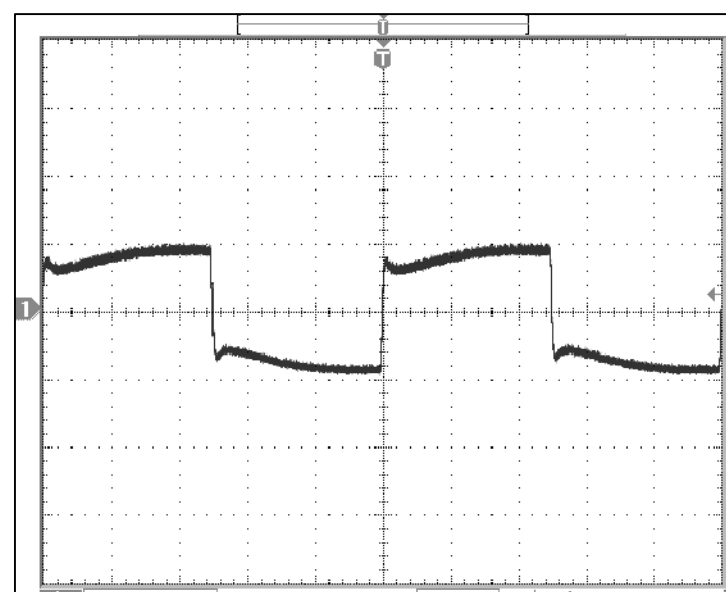

Figure 12
String Bass Switch In

1. Apply signal into the input with 200Hz square wave @ -46dBV(5mVrms).
2. Set Volume, all Active EQ's, Boost and Master to center(halfway), Contour and Presence to 0.
3. Look at output with scope set on 5V/div and 1ms/div.

HOLE REFERENCE CHART		
HOLE	DESCRIPTION	QTY.

QTY PER ASSY	PART NUMBER	DESCRIPTION	DESIGNATION(S)	ITEM NO.
PROPRIETARY				
PARTS LIST				
THIS DRAWING CONTAINS INFORMATION WHICH IS PROPRIETARY TO GALLIEN TECHNOLOGY CORPORATION. DO NOT REPRODUCE IN ANY FORM OR DISTRIBUTE IN ANY FASHION WITHOUT THE EXPRESS WRITTEN PERMISSION OF GALLIEN TECHNOLOGY CORPORATION.				
gallien technology 2234 INDUSTRIAL DRIVE STOCKTON, CA 95206				
TITLE: 400RB-IV				
UNLESS OTHERWISE INDICATED DIMENSIONS SHOWN ARE IN INCHES		APPROVALS		
TOLERANCES FRACTION ± ANGLES ± .XX ± 0.01 .XXX ± 0.005		INIT: DATE: MECH. DESIGN: ELEC: DRAWN BY: EAH 8/19/04 PROJ. MGR.: Q/A: RELEASED:		
MATERIAL: (SEE NOTE 1) FINISH: (SEE NOTE 1)		SIZE: DRAWING NUMBER: B 206-0241-A2 PART NUMBER: FILENAME: SCALE: NOT TO SCALE SHEET 2 OF 2		
REVISION: A2		REVISION: A2		

A

B

C

D

E

F

REVISION RECORD			
LTR	ECO NO:	APPROVED:	DATE:

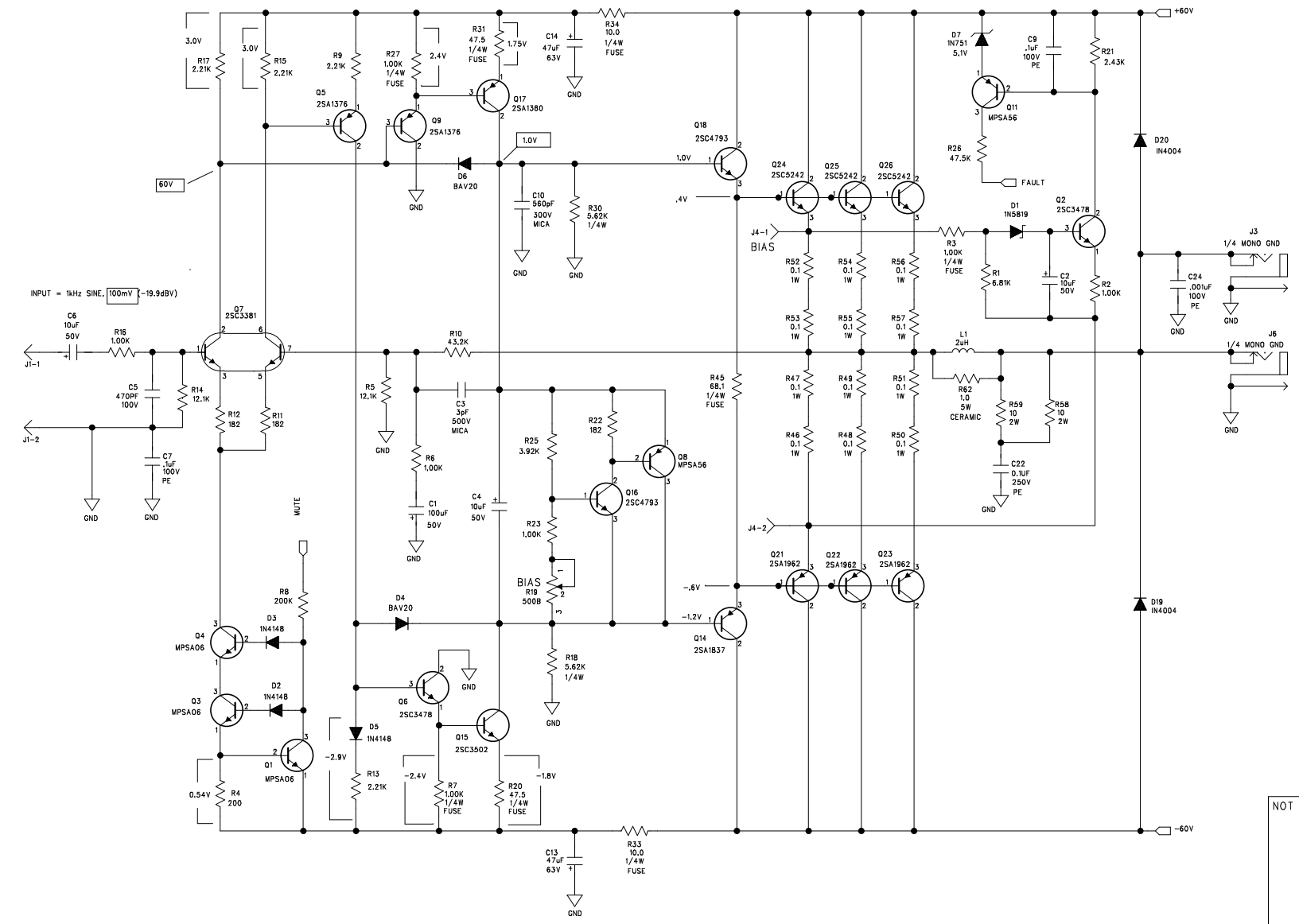
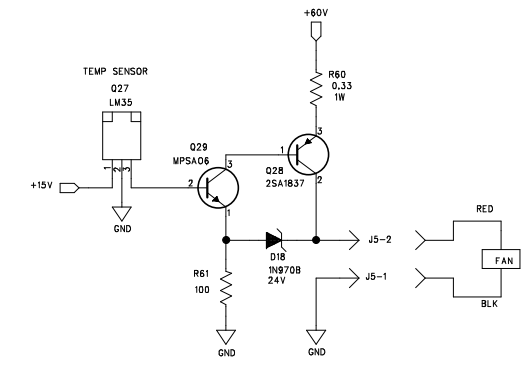
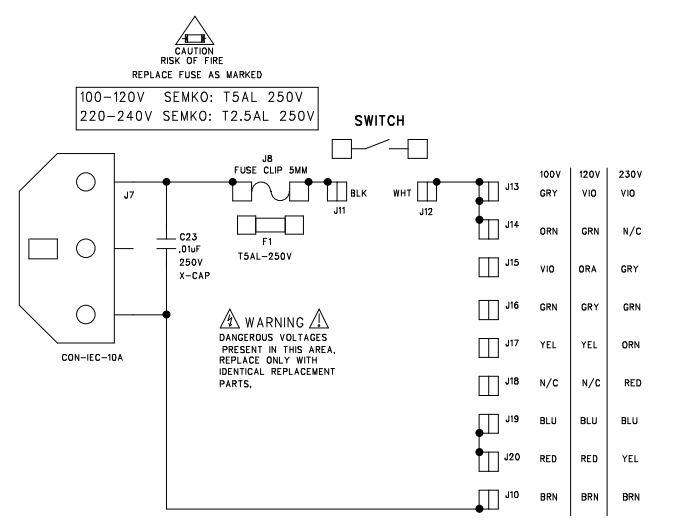
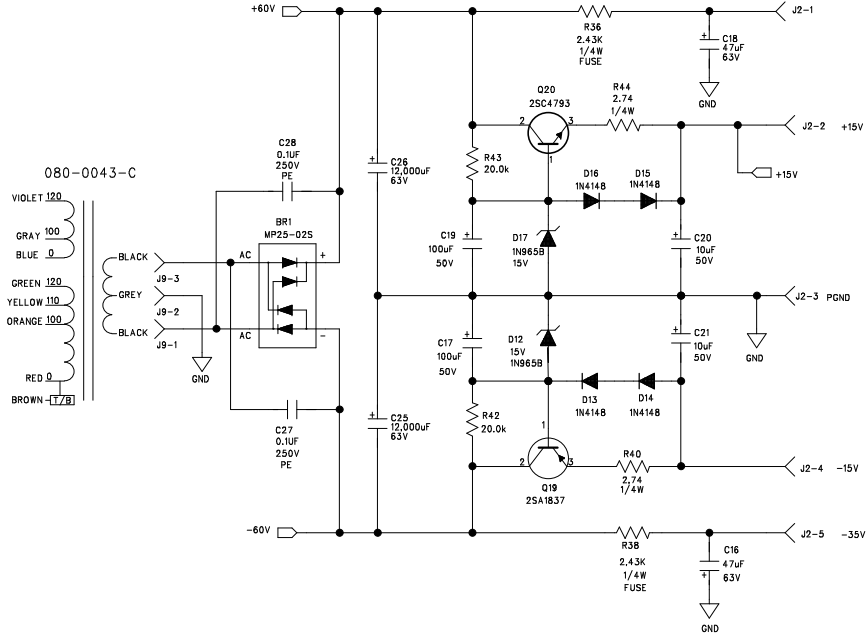
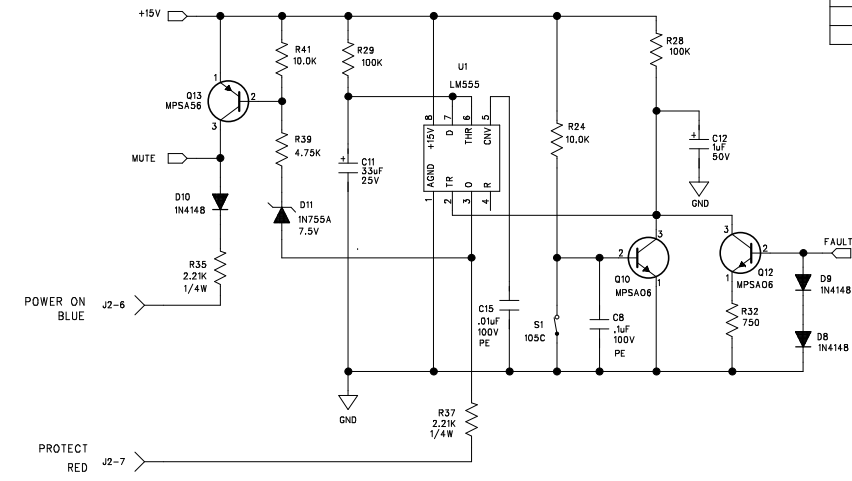

NOTES: UNLESS OTHERWISE SPECIFIED,
 1. TEST CONDITIONS: 100mV 1kHz SINE, DIRECT INPUT (PRE-AMP BYPASSED) NO LOAD
 2. DENOTES RMS AC VOLTAGE

BIAS ADJUSTMENT PROCEDURE:
 WITH POWER OFF, ADJUST POT R21 TO FULL COUNTER-CLOCKWISE POSITION. TURN ON POWER AND WAIT 5 SECONDS FOR TURN ON DELAY. TURN R21 CLOCKWISE UNTIL VOLTAGE ACROSS P3 READS 10 mVDC.

MH.200V 1 X6	MH.200V 1 X5	MH.125/220 1 X7
MH.200V 1 X4	MH.200V 1 X3	MH.125/220 1 X2
		MH.125/220 1 X1

NOT VALID UNLESS STAMP IS RED

gallien technology

2240 PARAGON DRIVE
 SAN JOSE CA. 95131
 VOICE: 408-441-8081
 FAX: 408-441-8085

TITEL: 400RB-IV POWER AMP	
DESIGNED: R.A.G. 11/9/99	DATE: 11/26/02
DRAWN: R.A.G.	REV: A
ELEC:	PART NO: 206-0240-A
MECH:	COMPANY: GALLIEN KRUEGER
Q/A:	FILENAME: 6240A.sch
RELEASED:	

NOTES THIS REV:
 1. TRANSFERRED FROM 206-0121-E1, NEW SYSTEM
 2. ADD 5.1V ZEN TO Q1-E.
 3. REMOVE R1 FROM REV 0121-E1.

GK GALLIEN-KRUEGER

400RB-IV Power Amp

Part No.	Reference	Description	Manufacturer	Mfr. Part No.
001-2060-0	U1	LM555, TIMER	NATIONAL	LM555CN
010-0000-0	Q7	2SC3381BL,NPNX2,80V,100MA,2-10M1B	TOSHIBA	2SC3281BL
010-0001-0	Q2 Q6	2SC3478, NPN, 180V, 100MA, TO-92	NEC	2SC3478-K
010-0003-0	Q15	2SC3502-F,NPN,200V,100MA,TO-126	TOSHIBA	2SC3502
010-0012-0	Q1 Q3-4 Q10 Q12 Q29	MPSAO6, NPN,80V,500MA,TO-92	MOTOROLA	MPS-A06
010-0035-0	Q27	LM35DT, TEMPERATURE SENSOR, TO-220	NATIONAL	LM35DT
010-1002-0	Q5 Q9	2SA1376, PNP,180V,100MA,TO-92	NEC	2SA1376-K
010-1003-0	Q17	2SA1380-F,PNP,200V,100MA,TO-126	SANYO/TOSHIBA	2SA1380-F/E
010-1013-0	Q8 Q11 Q13	MPSA56 PNP 80V 500MA TO-92	MOTOROLA	MPS-A56
012-0002-0	Q16 Q18 Q20	2SC4793,NPN,200V,1.5A,2-10R1A	TOSHIBA	2SC4793
012-0003-0	Q24-26	2SC5242,NPN,230V,15A,2-16C1A	TOSHIBA	2SC5242-O
012-1002-0	Q14 Q19 Q28	2SA1837,PNP,200V,1.5A,2-10R1A	TOSHIBA	2SA1837
012-1003-0	Q21-23	2SA1962,PNP,230V,15A,2-16C1A	TOSHIBA	2SA1962
020-0004-0	D11	1N755A, ZENER,7.5V,500MW ,D035	TAITRON	1N755A
020-0050-0	D7	1N751, ZENER,5.1V,10%,400MW,DO-35	NATIONAL	1N751
020-0150-0	D12 D17	1N965B, ZENER, 15V, 5%, 500mW, DO-35	TAITRON	1N965B
020-0240-0	D18	1N970B, ZENER, 24V, 5%, 500MW, DO-35	TAITRON	1N970B
020-1000-0	D2-3 D5 D8-10 D13-16	1N4148, RECT-FAST, 200MA, 100V	MOTOROLA	1N4148
020-1022-0	D4 D6	BAV20, RECT, 200V, DO-35	NATIONAL	BAV20
020-1104-0	D1	SHOTTKY, 1A, 40V, 10NS, DO-41	MOTOROLA	1N5819
020-2106-0	D19-20	1N4004,RECT,1A,400V,DO-41	TAITRON	1N4004
023-0112-0	BR1	BRIDGE, 25A, 200V, VERT, PC, MO25S-02	CHENG-YI	MP25-02S
031-1336-0	C11	CAP,ELEC,RAD,336,20%,25V	UNITED CHEMI-CON	SRG25VB33RM5X7LL
031-2105-0	C12	CAP,ELEC,RAD, 105, 20%, 50V	UNITED CHEMI-CON	C440C105M5U5CA
031-2106-0	C2 C4 C6 C20-21	CAP,ELEC,RAD, 106, 20%, 50V	UNITED CHEMI-CON	SMG50VB10RM5X11LL
031-2107-0	C1 C17 C19	CAP,ELEC,RAD,107, 20%, 50V	UNITED CHEMI-CON	SMG50VB101M8X11LL
031-3129-0	C25-26	CAP, ELEC, RAD, 129, 20%, 63V	UNITED CHEMI-CON	SMH63VN123M35X45T2
031-3476-0	C13-14 C16 C18	CAP,ELEC,RAD,476,20%,63V	UNITED CHEMI-CON	SMG63VB47RM6X11LL
032-4102-0	C24	CAP,PE,102,5%,100V,	PANASONIC	ECQB1102JF
032-4103-0	C15	CAP,PE,103,5%,100V,	PANASONIC	ECQV1103JM
032-4104-0	C7-9	CAP,PE,104,5%,100V,	PANASONIC	ECQV1104JM
032-7104-0	C22 C27-28	CAP,PE,104,10%, 250V	ILLINOIS CAPACITOR	104MSR250K
034-4471-0	C5	CAP,MCR,470pF,5%,100V,	TAITRON	TMRS471J100NPOB
034-7103-0	C23	CAP, CERMIC DISK, 103, 10%, X-250V	PANASONIC	ECK-DRS103ZV
035-8030-0	C3	CAP MICA AXIAL , 3pF, 10%, 500V	CORNELL	CD10CD030D03
035-8561-0	C10	CAP MICA RADIAL, 561, 5%, 300V	CORNELL	CD15FC561J103
052-2.74-0	R40 R44	RES,METAL FILM, 2.74, 1/4W, 1%	ECI	M2F1AJ002.74
052-2212-0	R35 R37	RES,METAL FILM,2.21k,1/4W,1%	ECI	M2F1AK002.21
052-5622-0	R18 R30	RES,METAL FILM,5.62K,1/4W,1%	ECI	M5F1AK005.62
054-.100-0	R46-57	RES, METAL OXIDE, 0.1 Ohm, 1W, 5%	ECI	MO10J3AJ000.10
054-.330-0	R60	RES, METAL OXIDE, 0.33 OHM, 1W, 5%	ECI	MO10J3AJ000.33
055-0101-0	R58-59	RES, METAL OXIDE, 10 OHM, 2W, 5%	ECI	MOM20J3AJ010.00
056-0100-0	R62	RES, CERAMIC WW, 1.0 OHM, 5W, 10%	ECI	WWC50J3AJ001.00
059-1000-0	R33-34	RES,MF,FUSE,10.0 OHM, 1/4W,1%	JUKN.OHM	FR25-10.0
059-1002-0	R3 R7 R27	RES,MF,FUSE,1.00K,1/4W,1%	JUKN.OHM	FR25-1.00K
059-2432-0	R36 R38	RES,MF,FUSE,2.43K, 1/4W,1%	JUKN.OHM	FR25-2.43K
059-4750-0	R20 R31	RES,MF,FUSE,47.5 OHM, 1/4W,1%	JUKN.OHM	FR25-47.5
059-6810-0	R45	RES,MF,FUSE,68.1 OHM, 1/4W,1%	JUKN.OHM	FR25-68.1
060-1001-0	R61	RES, METAL FILM, 100 OHM, 1/8W, 1%	ECI	M1F1AJ100.00
060-1002-0	R2 R6 R16 R23	RES,METAL FILM, 1.00K, 1/8W, 1%	ECI	M1F1AK001.00
060-1003-0	R24 R41	RES,METAL FILM, 10.0K, 1/8W,1%	ECI	M1F1AK010.00
060-1004-0	R28-29	RES,METAL FILM, 100K, 1/8W, 1%	ECI	M1F1AK100.00
060-1213-0	R5 R14	RES,METAL FILM, 12.1K OHM, 1/8W, 1%	ECI	M1F1AK012.10
060-1821-0	R11-12 R22	RES,METAL FILM, 182, 1/8W, 1%	ECI	M1F1AJ182.00
060-2001-0	R4	RES,METAL FILM, 200, 1/8W, 1%	ECI	M1F1AJ200.00
060-2003-0	R42-43	RES,METAL FILM, 20.0K, 1/8W, 1%	ECI	M1F1AK020.00
060-2004-0	R8	RES,METAL FILM, 200K, 1/8W, 1%	ECI	M1F1AK200.00
060-2212-0	R9 R13 R15 R17	RES,METAL FILM, 2.21K, 1/8W, 1%	ECI	M1F1AK002.21
060-2432-0	R21	RES,METAL FILM, 2.43K, 1/8W, 1%	ECI	M1F1AK002.43
060-3922-0	R25	RES,METAL FILM, 3.92K, 1/8W, 1%	ECI	M1F1AK003.92
060-4323-0	R10	RES,METAL FILM, 43.2K, 1/8W, 1%	ECI	M1F1AK043.20
060-4752-0	R39	RES,METAL FILM, 4.75K, 1/8W, 1%	ECI	M1F1AK004.75
060-4753-0	R26	RES,METAL FILM, 47.5K, 1/8W, 1%	ECI	M1F1AK047.50
060-6812-0	R1	RES,METAL FILM, 6.81K, 1/8W, 1%	ECI	M1F1AK006.81
060-7501-0	R32	RES,METAL FILM, 750 OHM, 1/8W, 1%	ECI	M1F1AJ750.00

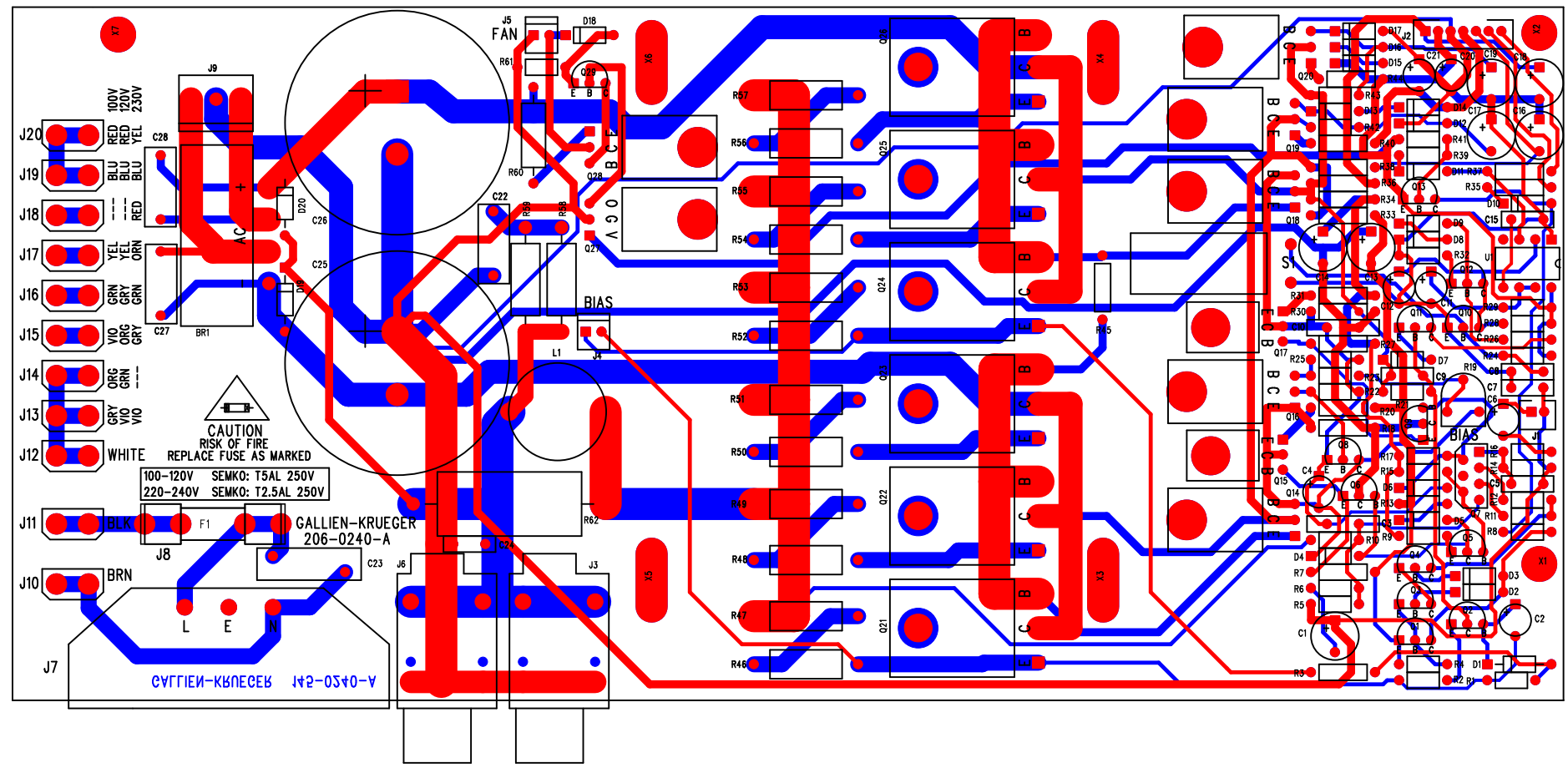

PCB WORK INSTRUCTIONS

DWG 420-0240-A

NOTES:

UNLESS OTHERWISE SPECIFIED:

1. SQUARE PADS ON PARTS DENOTE PIN 1.
2. ALL BOARDS REQUIRE A COMPLETE VISUAL INSPECTION.
3. ALL BOARDS MUST BE BARE BOARD TESTED.
4. ASSEMBLE AND SOLDER PER ANSI/IPC-A-610B.

LOADING

5. SEE FORMING AND LOADING INSTRUCTIONS BELOW FOR INSTALLING SPECIFIED COMPONENTS.
6. CHECK THAT R45-56 ARE FULSH WITH PCB.
7. CHECK THAT J3, 6, 7, & S1 ARE FLUSH WITH PCB.
8. MAKE CERTAIN ALL POWER TRANSISTOR MOUNTING HOLES ARE PROPERLY ALIGNED FOR HEAT SINK.

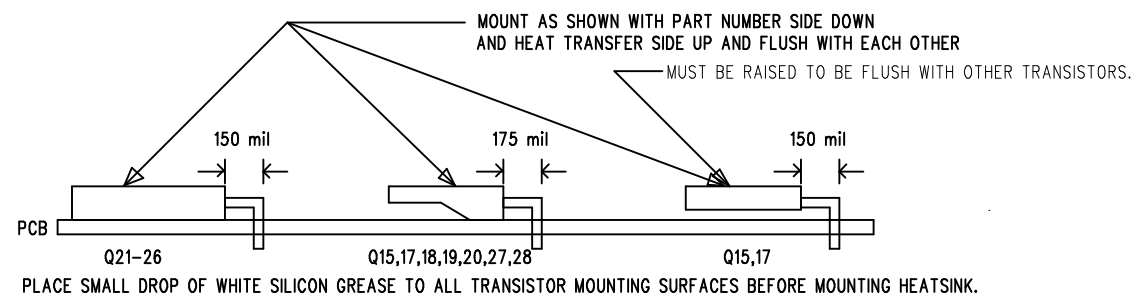

NOT VALID UNLESS STAMP IS RED		2240 PARAGON DRIVE SAN JOSE CA. 95131 VOICE: 408-441-8081 FAX: 408-441-8085	
gallien technology		TITLE: 400RB-IV POWER AMP	
APPROVALS		INIT DATE	
DESIGNED:	R.A.G.	6/25/02	SIZE
DRAWN:	R.A.G.	11/26/02	DRAWING NO: 405-0240-A
ELEC:			REV. A
MECH:			PART NO: 145-0240-A
GERBER FILE NAME: st0126.pho		COMPANY: GALLIEN-KRUEGER	
		FILENAME: 5240A.PCB	
LAYER DESCRIPTION: TOP SIDE SOLDERSCREEN			

APPLY THERMAL TAPE (105-0014-0) AND ALIGN WITH THIS EDGE.

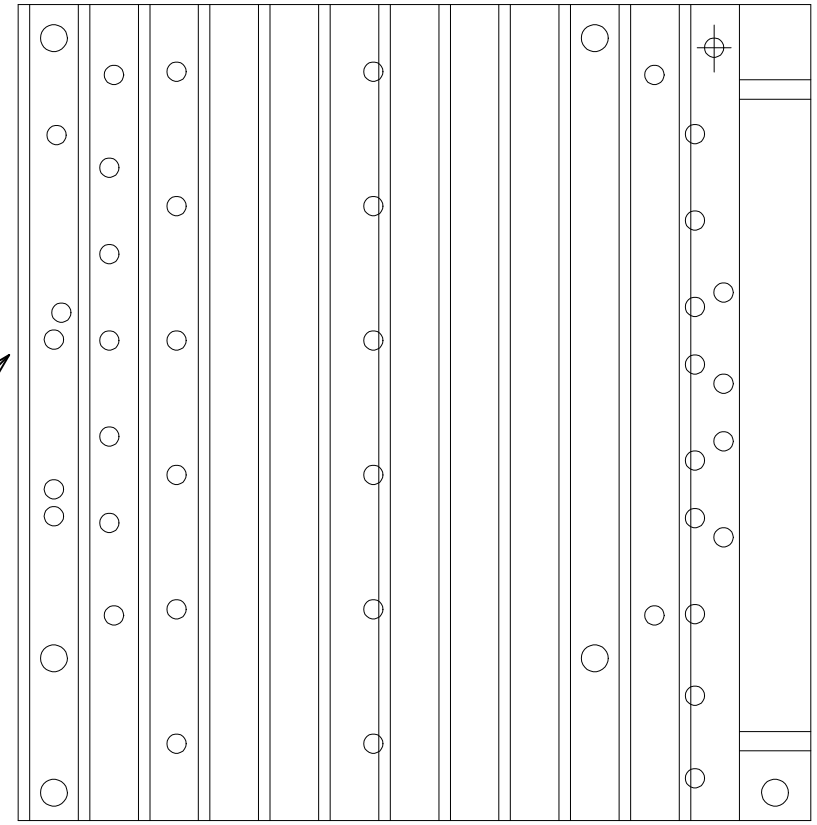

REVISION RECORD			
LTR	ECCO NO:	APPROVED:	DATE:

6 5 4 3 2 1

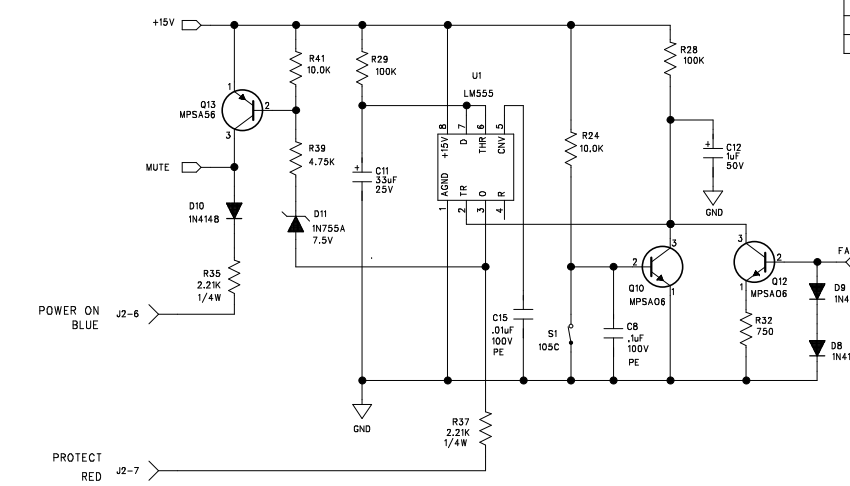
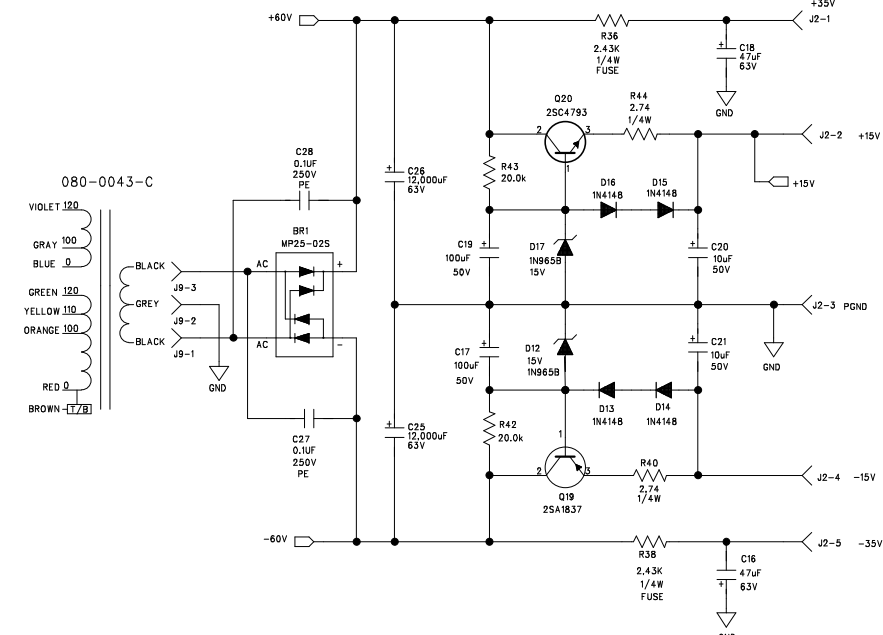
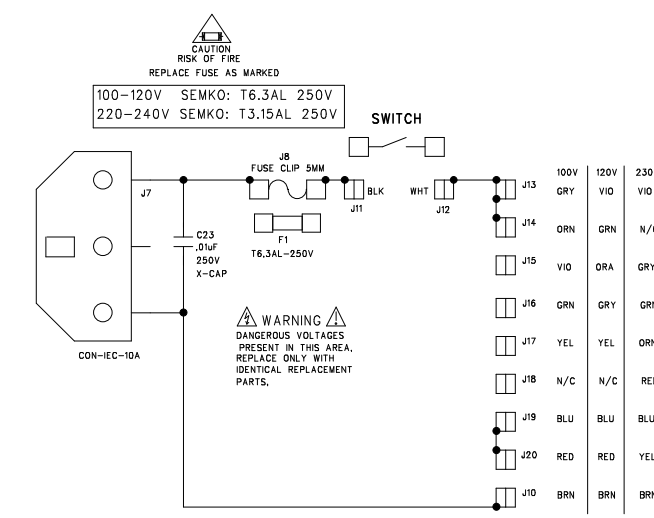

D

C

B

A

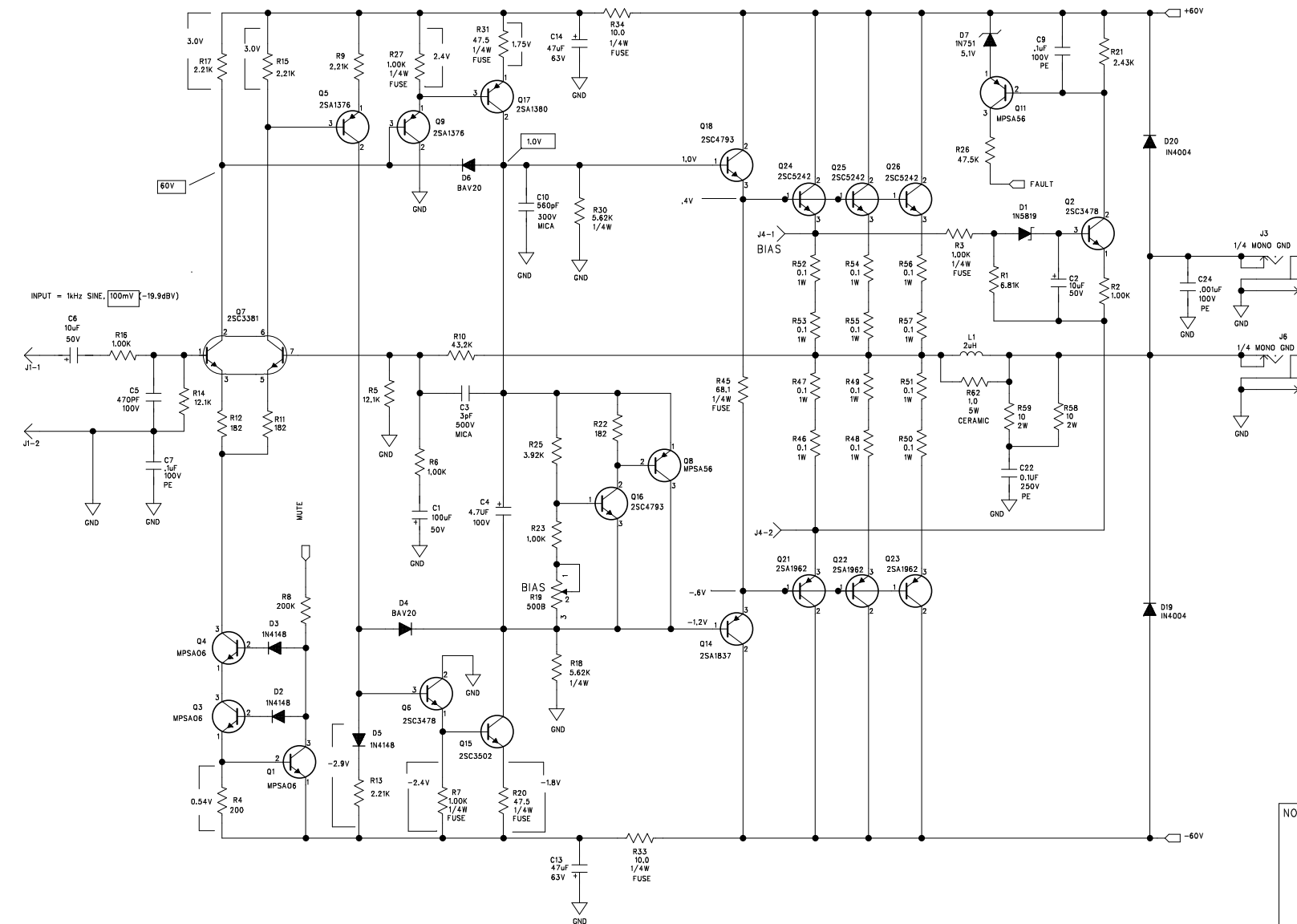

- NOTES: UNLESS OTHERWISE SPECIFIED,
- TEST CONDITIONS: 100mV 1kHz SINE, DIRECT INPUT (PRE-AMP BYPASSED) NO LOAD
 - DENOTES RMS AC VOLTAGE

BIAS ADJUSTMENT PROCEDURE:
WITH POWER OFF, ADJUST POT R21 TO FULL COUNTER-CLOCKWISE POSITION.
TURN ON POWER AND WAIT 5 SECONDS FOR TURN ON DELAY.
TURN R21 CLOCKWISE UNTIL VOLTAGE ACROSS P3 READS 10 mVDC.

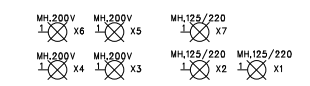

D

C

B

A

NOT VALID UNLESS STAMP IS RED

gallien technology

2234 INDUSTRIAL DRIVE
STOCKTON CA. 95206
VOICE: 209-234-7300
FAX: 209-234-8420

TITLE: 400RB-IV POWER AMP

DESIGNED: R.A.G. 11/9/99
DRAWN: R.A.G. 5/30/03

DATE: 11/9/99
DATE: 5/30/03

SIZE: B
DRAWING NO: 406-0240-A1
PART NO: 206-0240-A1

COMPANY: GALLIEN KRUEGER
FILENAME: 6240A1.sch

REV: A1

NOTES THIS REV:
1. CHANGED C4 TO 4.8uF/100V.
2. CHANGED F1 TO 16.3AL FOR 120V.
3. CHANGED F1 TO 3.15AL FOR 230V.
4. UPDATED REV TO A1.

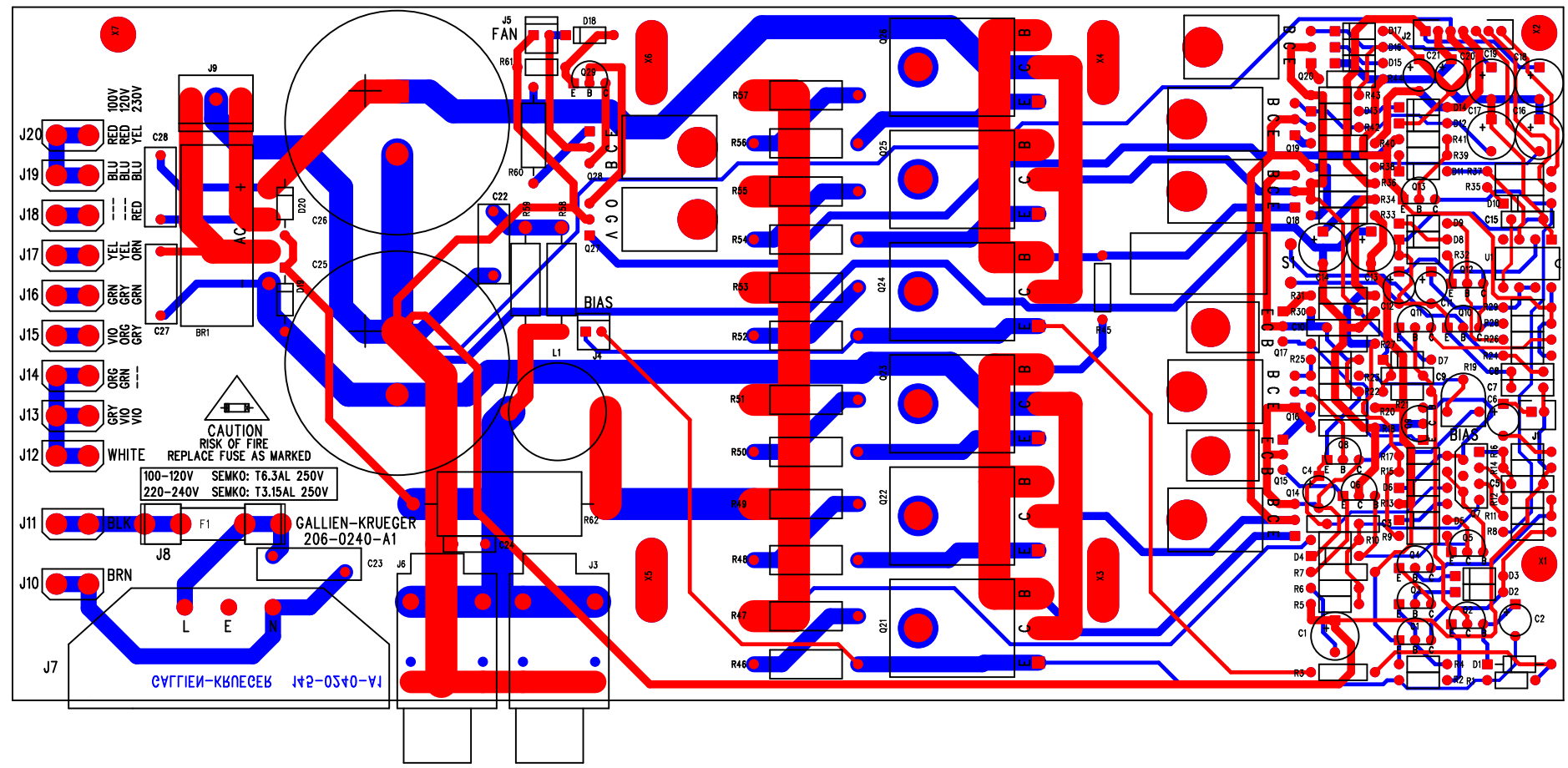

PCB WORK INSTRUCTIONS

DWG 420-0240-A1

NOTES:

UNLESS OTHERWISE SPECIFIED:

1. SQUARE PADS ON PARTS DENOTE PIN 1.
2. ALL BOARDS REQUIRE A COMPLETE VISUAL INSPECTION.
3. ALL BOARDS MUST BE BARE BOARD TESTED.
4. ASSEMBLE AND SOLDER PER ANSI/IPC-A-610B.

LOADING

5. SEE FORMING AND LOADING INSTRUCTIONS BELOW FOR INSTALLING SPECIFIED COMPONENTS.
6. CHECK THAT R45-56 ARE FLUSH WITH PCB.
7. CHECK THAT J3, 6, 7, & S1 ARE FLUSH WITH PCB.
8. MAKE CERTAIN ALL POWER TRANSISTOR MOUNTING HOLES ARE PROPERLY ALIGNED FOR HEAT SINK.

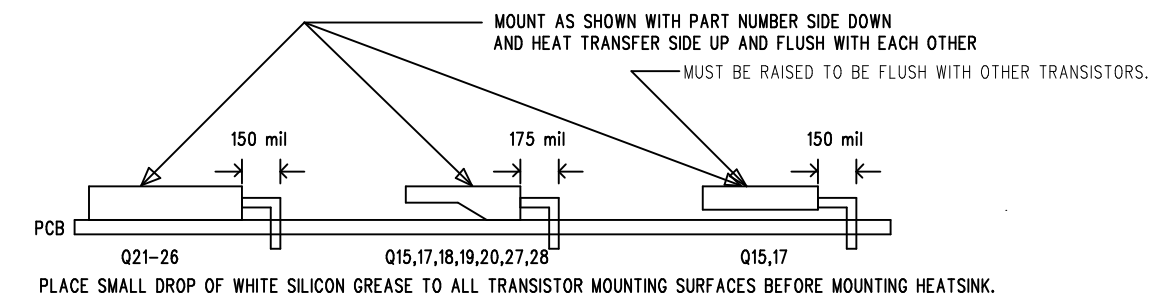

NOT VALID UNLESS STAMP IS RED		2240 PARAGON DRIVE SAN JOSE CA. 95131 VOICE: 408-441-8081 FAX: 408-441-8085	
gallien technology		TITLE: 400RB-IV POWER AMP	
APPROVALS		INIT	
DESIGNED: R.A.G.	6/25/02	DATE	
DRAWN: R.A.G.	6/02/03	SIZE	
ELEC:		DRAWING NO: 405-0240-A1	REV. A1
		PART NO: 145-0240-A1	
LAYER DESCRIPTION:		COMPANY: GALLIEN-KRUEGER	
TOP SIDE ROUTING SCREEN		FILENAME: 5240A1.PCB	
MECH:		GERBER FILE NAME: sst0126.pho	

APPLY THERMAL TAPE (105-0014-0) AND ALIGN WITH THIS EDGE.

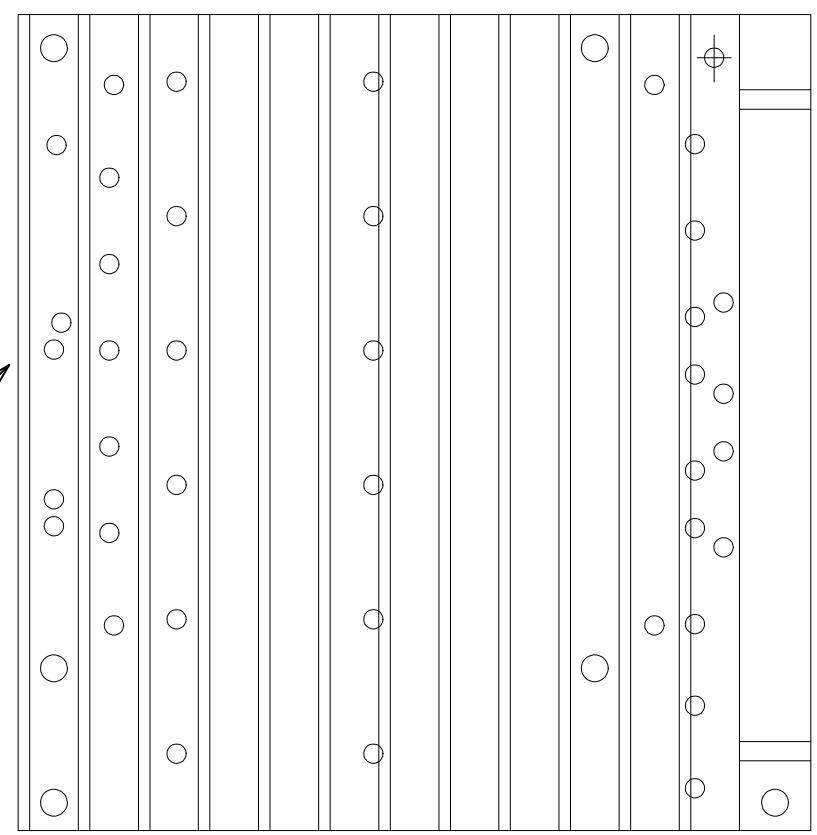

Customer Name: Gallien-Krueger		Current Rev #: A1		New ECO Rev #: A2	
Model: 400RB-IV		Distribute To:		Page: 1 Of: 1	
Assembly Description: Power Amp		Originator: RAG			
Assembly Numbers: 206-0240-A 145-0240-A		Approved by:			
		Effective Date:			
Effective			Document Update		Date
<input type="checkbox"/>	All in Process	<input checked="" type="checkbox"/>	Next Buy	<input type="checkbox"/>	Artwork
<input type="checkbox"/>	All in Service	<input type="checkbox"/>	Next Production Run	<input type="checkbox"/>	Assembly Dwg.
<input type="checkbox"/>	All in Stock	<input type="checkbox"/>		<input checked="" type="checkbox"/>	Board Artwork
Beginning Serial Number:				<input checked="" type="checkbox"/>	BOM
Reason For Change					
Add 240V supply table to board and schematic.			<input type="checkbox"/>		Control Form
			<input type="checkbox"/>		Costing
			<input type="checkbox"/>		Fab Drawing
			<input type="checkbox"/>		Inspection Proc.
			<input checked="" type="checkbox"/>		Part Master File
			<input checked="" type="checkbox"/>		Schematic
			<input checked="" type="checkbox"/>		Service Manual
			<input type="checkbox"/>		Test Procedure
			<input type="checkbox"/>		
			Other Affected Assemblies		
			290 Assemblies , 302 Assembly (Head)		
			303 Assemblies (Combo)		
<input type="checkbox"/>	Continued on ECO Supplement Page				
Description Of Change			Distribution		Date
			<input type="checkbox"/>		Accounting
			<input type="checkbox"/>		Assembly
			<input checked="" type="checkbox"/>		Engineering
			<input checked="" type="checkbox"/>		Incoming Q.C.
			<input checked="" type="checkbox"/>		Production Eng.
			<input checked="" type="checkbox"/>		Purchasing
			<input type="checkbox"/>		Q.A.
			<input type="checkbox"/>		Service
			<input checked="" type="checkbox"/>		Test
<input type="checkbox"/>	Continued on Supplement Page		<input type="checkbox"/>		Drawing(s) attached
Part Number	Description	Parts Added		Parts Deleted	
		Qty	Ref. Designator	Qty	Ref. Designator

REVISION RECORD			
LTR	ECCO NO:	APPROVED:	DATE:

6 5 4 3 2 1

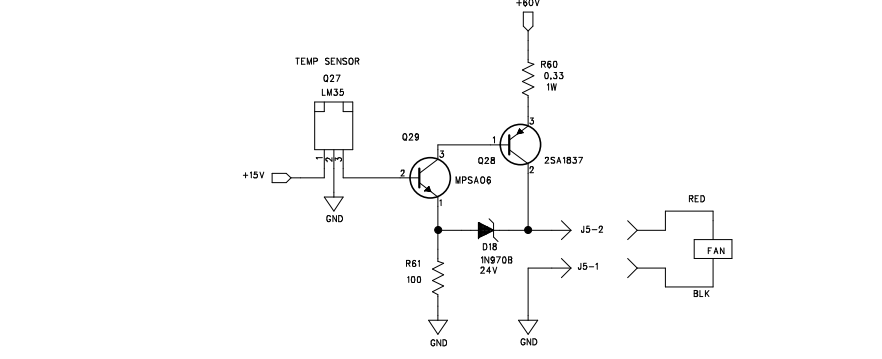
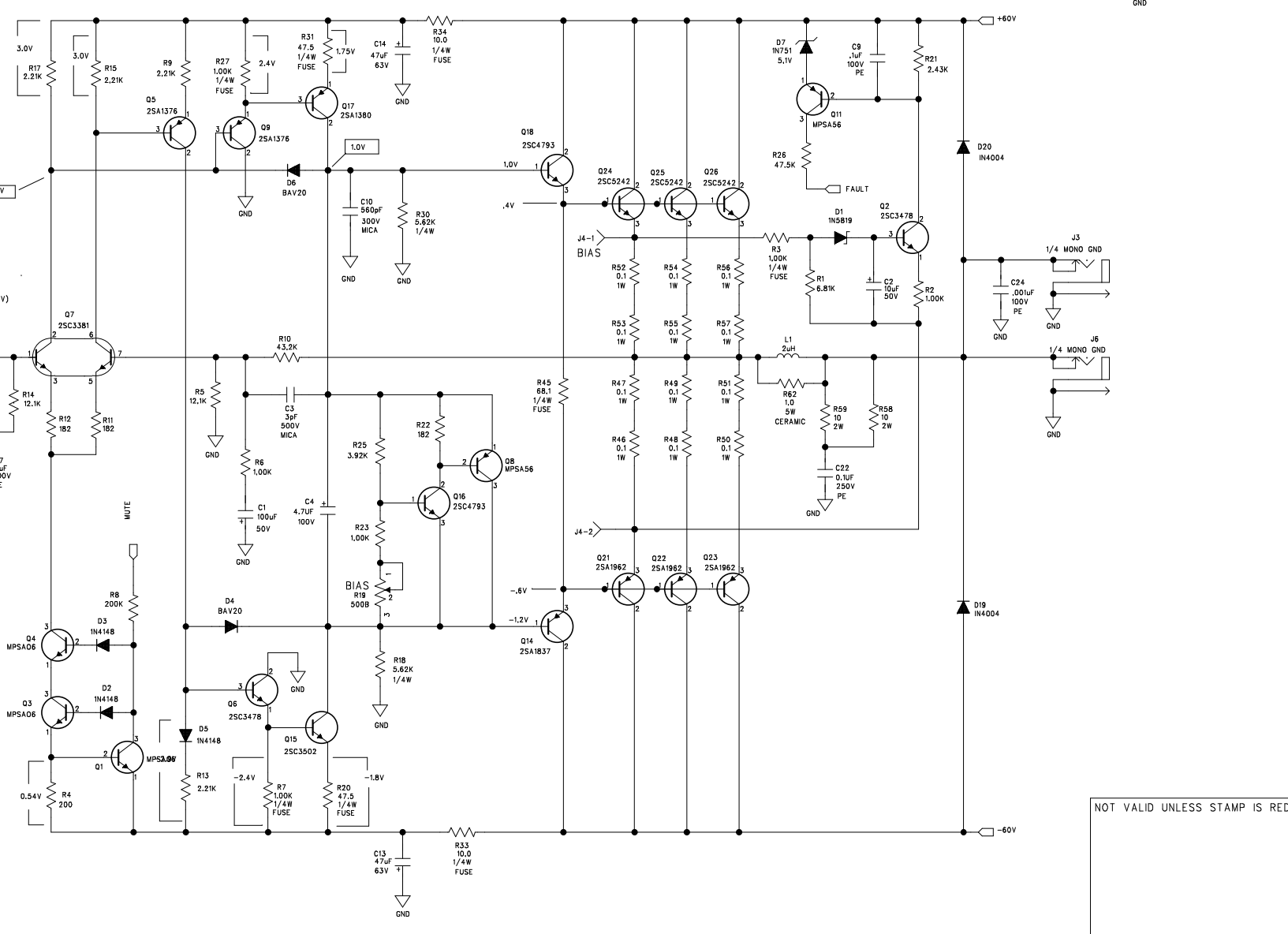
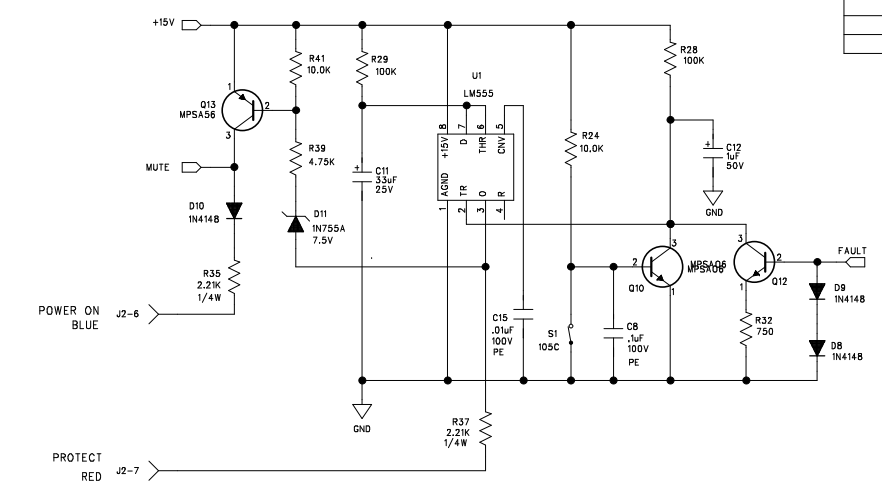
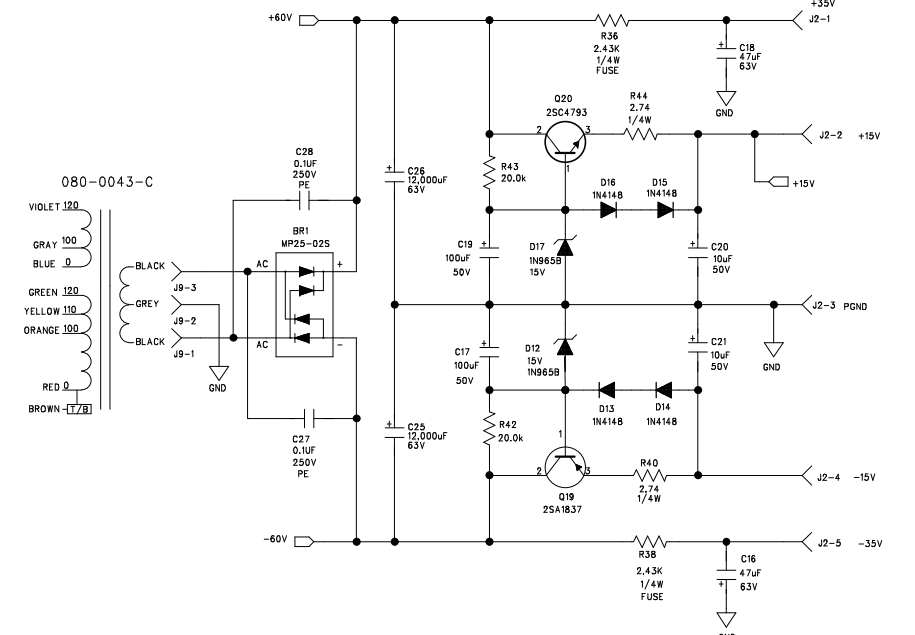
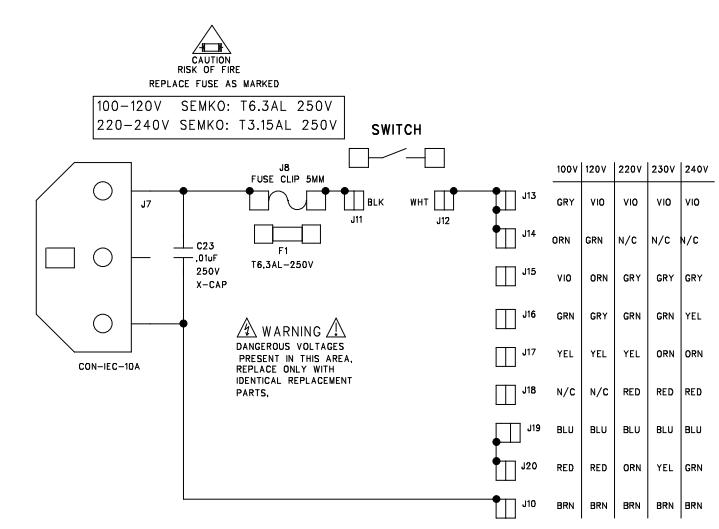

- NOTES: UNLESS OTHERWISE SPECIFIED,
- TEST CONDITIONS: 100mV 1kHz SINE, DIRECT INPUT (PRE-AMP BYPASSED) NO LOAD
 - DENOTES RMS AC VOLTAGE

BIAS ADJUSTMENT PROCEDURE:
 WITH POWER OFF, ADJUST POT R21 TO FULL COUNTER-CLOCKWISE POSITION.
 TURN ON POWER AND WAIT 5 SECONDS FOR TURN ON DELAY.
 TURN R21 CLOCKWISE UNTIL VOLTAGE ACROSS P3 READS 10 mVDC.

MH 200V	MH 200V	MH 125/220
1 X6	1 X5	1 X7
MH 200V	MH 200V	MH 125/220
1 X4	1 X3	1 X2
		1 X1

NOT VALID UNLESS STAMP IS RED

gallien technology

2234 INDUSTRIAL DRIVE
 STOCKTON CA. 95206
 VOICE: 209-234-7300
 FAX: 209-234-8420

NOTES REV A2:
 1. ADD 240V SUPPLY TABLE TO LAYOUT.

APPROVALS		DATE		TITLE	
INIT	DATE	400RB-IV POWER AMP			
DESIGNED: R.A.G.	11/9/99	REV:	A2		
DRAWN: R.A.G.	11/19/03	SIZE:	B		
ELEC:		DRAWING NO:	406-0240-A2		
MECH:		PART NO:	206-0240-A2		
Q/A:		COMPANY:	GALLIEN KRUEGER		
RELEASED:		FILENAME:	6240A2.sch		

GALLIEN-KRUEGER

400RB-IV Power Amp

Part No.	Reference	Description	Manufacturer	Mfr. Part No.
001-2060-0	U1	LM555, TIMER	NATIONAL	LM555CN
010-0000-0	Q7	2SC3381BL,NPNX2,80V,100MA,2-10M1B	TOSHIBA	2SC3281BL
010-0001-0	Q2 Q6	2SC3478, NPN, 180V, 100MA, TO-92	NEC	2SC3478-K
010-0003-0	Q15	2SC3502-F,NPN,200V,100MA,TO-126	TOSHIBA	2SC3502
010-0012-0	Q1 Q3-4 Q10 Q12 Q29	MPSAO6, NPN,80V,500MA,TO-92	MOTOROLA	MPS-A06
010-0035-0	Q27	LM35DT, TEMPERATURE SENSOR, TO-220	NATIONAL	LM35DT
010-1002-0	Q5 Q9	2SA1376, PNP,180V,100MA,TO-92	NEC	2SA1376-K
010-1003-0	Q17	2SA1380-F,PNP,200V,100MA,TO-126	SANYO/TOSHIBA	2SA1380-F/E
010-1013-0	Q8 Q11 Q13	MPSA56 PNP 80V 500MA TO-92	MOTOROLA	MPS-A56
012-0002-0	Q16 Q18 Q20	2SC4793,NPN,200V,1.5A,2-10R1A	TOSHIBA	2SC4793
012-0003-0	Q24-26	2SC5242,NPN,230V,15A,2-16C1A	TOSHIBA	2SC5242-O
012-1002-0	Q14 Q19 Q28	2SA1837,PNP,200V,1.5A,2-10R1A	TOSHIBA	2SA1837
012-1003-0	Q21-23	2SA1962,PNP,230V,15A,2-16C1A	TOSHIBA	2SA1962
020-0004-0	D11	1N755A, ZENER,7.5V,500MW ,D035	TAITRON	1N755A
020-0050-0	D7	1N751, ZENER,5.1V,10%,400MW,DO-35	NATIONAL	1N751
020-0150-0	D12 D17	1N965B, ZENER, 15V, 5%, 500mW, DO-35	TAITRON	1N965B
020-0240-0	D18	1N970B, ZENER, 24V, 5%, 500MW, DO-35	TAITRON	1N970B
020-1000-0	D2-3 D5 D8-10 D13-16	1N4148, RECT-FAST, 200MA, 100V	MOTOROLA	1N4148
020-1022-0	D4 D6	BAV20, RECT, 200V, DO-35	NATIONAL	BAV20
020-1104-0	D1	SHOTTKY, 1A, 40V, 10NS, DO-41	MOTOROLA	1N5819
020-2106-0	D19-20	1N4004,RECT,1A,400V,DO-41	TAITRON	1N4004
023-0112-0	BR1	BRIDGE, 25A, 200V, VERT, PC, MO25S-02	CHENG-YI	MP25-02S
031-1336-0	C11	CAP,ELEC,RAD,336,20%,25V	UNITED CHEMI-CON	SRG25VB33RM5X7LL
031-2105-0	C12	CAP,ELEC,RAD, 105, 20%, 50V	UNITED CHEMI-CON	C440C105M5U5CA
031-2106-0	C2,6,20,21	CAP,ELEC,RAD, 106, 20%, 50V	UNITED CHEMI-CON	SMG50VB10RM5X11LL
031-2107-0	C1 C17 C19	CAP,ELEC,RAD,107, 20%, 50V	UNITED CHEMI-CON	SMG50VB101M8X11LL
031-3129-0	C25-26	CAP, ELEC, RAD, 129, 20%, 63V	UNITED CHEMI-CON	SMH63VN123M35X45T2
031-3476-0	C13-14 C16 C18	CAP,ELEC,RAD,476,20%,63V	UNITED CHEMI-CON	SMG63VB47RM6X11LL
031-4475-0	C4	CAP,ELEC,RAD, 475, 20%, 100V	UNITED CHEMI-CON	SMG100VB47RM5X11LL
032-4102-0	C24	CAP,PE,102,5%,100V,	PANASONIC	ECQB1102JF
032-4103-0	C15	CAP,PE,103,5%,100V,	PANASONIC	ECQV1103JM
032-4104-0	C7-9	CAP,PE,104,5%,100V,	PANASONIC	ECQV1104JM
032-7104-0	C22 C27-28	CAP,PE,104,10%, 250V	ILLINOIS CAPACITOR	104MSR250K
034-4471-0	C5	CAP,MCR,470pF,5%,100V,	TAITRON	TMRS471J100NPOB
034-7103-0	C23	CAP, CERMIC DISK, 103, 10%, X-250V	PANASONIC	ECK-DRS103ZV
035-8030-0	C3	CAP MICA AXIAL , 3pF, 10%, 500V	CORNELL	CD10CD030D03
035-8561-0	C10	CAP MICA RADIAL, 561, 5%, 300V	CORNELL	CD15FC561J103
052-2.74-0	R40 R44	RES,METAL FILM, 2.74, 1/4W, 1%	ECI	M2F1AJ002.74
052-2212-0	R35 R37	RES,METAL FILM,2.21k,1/4W,1%	ECI	M2F1AK002.21
052-5622-0	R18 R30	RES,METAL FILM,5.62K,1/4W,1%	ECI	M5F1AK005.62
054-100-0	R46-57	RES, METAL OXIDE, 0.1 Ohm, 1W, 5%	ECI	MO10J3AJ000.10
054-330-0	R60	RES, METAL OXIDE, 0.33 OHM, 1W, 5%	ECI	MO10J3AJ000.33
055-0101-0	R58-59	RES, METAL OXIDE, 10 OHM, 2W, 5%	ECI	MOM20J3AJ010.00
056-0100-0	R62	RES, CERAMIC WW, 1.0 OHM, 5W, 10%	ECI	VWC50J3AJ001.00
059-1000-0	R33-34	RES,MF,FUSE,10.0 OHM, 1/4W,1%	JUKN.OHM	FR25-10.0
059-1002-0	R3 R7 R27	RES,MF,FUSE,1.00K,1/4W,1%	JUKN.OHM	FR25-1.00K
059-2432-0	R36 R38	RES,MF,FUSE,2.43K, 1/4W,1%	JUKN.OHM	FR25-2.43K
059-4750-0	R20 R31	RES,MF,FUSE,47.5 OHM, 1/4W,1%	JUKN.OHM	FR25-47.5
059-6810-0	R45	RES,MF,FUSE,68.1 OHM, 1/4W,1%	JUKN.OHM	FR25-68.1
060-1001-0	R61	RES, METAL FILM, 100 OHM, 1/8W, 1%	ECI	M1F1AJ100.00
060-1002-0	R2 R6 R16 R23	RES,METAL FILM, 1.00K, 1/8W, 1%	ECI	M1F1AK001.00
060-1003-0	R24 R41	RES,METAL FILM, 10.0K, 1/8W,1%	ECI	M1F1AK010.00
060-1004-0	R28-29	RES,METAL FILM, 100K, 1/8W, 1%	ECI	M1F1AK100.00
060-1213-0	R5 R14	RES,METAL FILM, 12.1K OHM, 1/8W, 1%	ECI	M1F1AK012.10
060-1821-0	R11-12 R22	RES,METAL FILM, 182, 1/8W, 1%	ECI	M1F1AJ182.00
060-2001-0	R4	RES,METAL FILM, 200, 1/8W, 1%	ECI	M1F1AJ200.00
060-2003-0	R42-43	RES,METAL FILM, 20.0K, 1/8W, 1%	ECI	M1F1AK020.00
060-2004-0	R8	RES,METAL FILM, 200K, 1/8W, 1%	ECI	M1F1AK200.00
060-2212-0	R9 R13 R15 R17	RES,METAL FILM, 2.21K, 1/8W, 1%	ECI	M1F1AK002.21
060-2432-0	R21	RES,METAL FILM, 2.43K, 1/8W, 1%	ECI	M1F1AK002.43
060-3922-0	R25	RES,METAL FILM, 3.92K, 1/8W, 1%	ECI	M1F1AK003.92
060-4323-0	R10	RES,METAL FILM, 43.2K, 1/8W, 1%	ECI	M1F1AK043.20
060-4752-0	R39	RES,METAL FILM, 4.75K, 1/8W, 1%	ECI	M1F1AK004.75
060-4753-0	R26	RES,METAL FILM, 47.5K, 1/8W, 1%	ECI	M1F1AK047.50
060-6812-0	R1	RES,METAL FILM, 6.81K, 1/8W, 1%	ECI	M1F1AK006.81
060-7501-0	R32	RES,METAL FILM, 750 OHM, 1/8W, 1%	ECI	M1F1AJ750.00



PCB WORK INSTRUCTIONS

DWG 420-0240-A2

NOTES:

UNLESS OTHERWISE SPECIFIED:

1. SQUARE PADS ON PARTS DENOTE PIN 1.
2. ALL BOARDS REQUIRE A COMPLETE VISUAL INSPECTION.
3. ALL BOARDS MUST BE BARE BOARD TESTED.
4. ASSEMBLE AND SOLDER PER ANSI/IPC-A-610B.

LOADING

5. SEE FORMING AND LOADING INSTRUCTIONS BELOW FOR INSTALLING SPECIFIED COMPONENTS.
6. CHECK THAT R45-56 ARE FLUSH WITH PCB.
7. CHECK THAT J3, 6, 7, & S1 ARE FLUSH WITH PCB.
8. MAKE CERTAIN ALL POWER TRANSISTOR MOUNTING HOLES ARE PROPERLY ALIGNED FOR HEAT SINK.

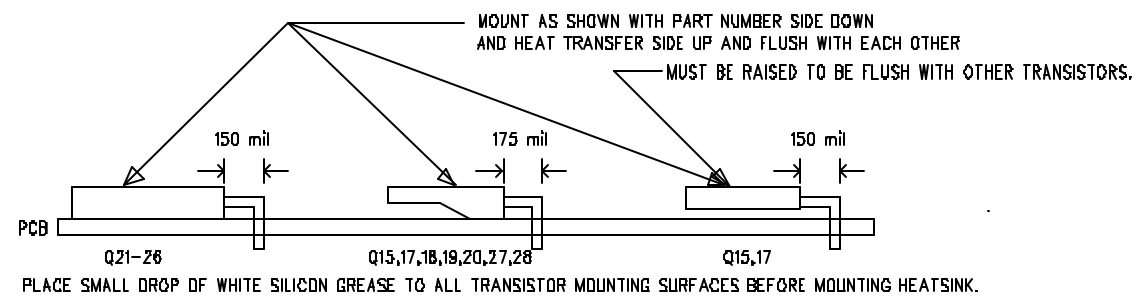

NOT VALID UNLESS STAMP IS RED				2234 INDUSTRIAL DRIVE STOCKTON CA. 95208 VOICE: 209-234-7300 FAX: 209-234-8420	
APPROVALS			TITLE: 400RB-IV POWER AMP		
INIT	DATE		SIZE	DRAWING NO:	REV.
DESIGNED:	R.A.G.	6/25/02	B	405-0240-A2	A2
DRAWN:	R.A.G.	11/19/03		PART NO:	
ELEC:			COMPANY:	GALLIEN-KRUEGER	
MECH:			FILENAME:	5240A2.PCB	
GERBER FILE NAME:			5240A2.pho		
LAYER DESCRIPTION:					
TOP SIDE MASKSCREEN					

APPLY THERMAL TAPE (105-0014-0) AND ALIGN WITH THIS EDGE.

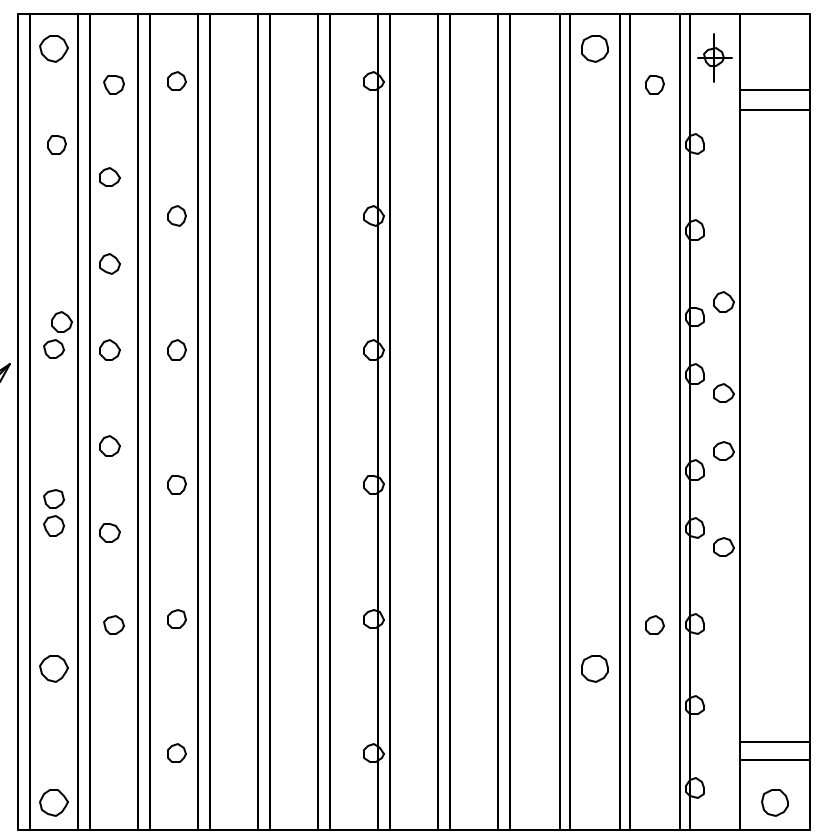

Customer Name:		Gallien-Krueger		Current Rev #:		A2		New ECO Rev #:		A3	
Model:		400RB-IV		Distribute To:				Page:		1 Of: 1	
Assembly Description:		Power Amp		Originator:		RAG					
Assembly Numbers:		206-0240-A 145-0240-A		Approved by:							
				Effective Date:		12/14/2003					

Effective		Document Update		Date	Initials
<input checked="" type="checkbox"/>	All in Process	<input checked="" type="checkbox"/>	Next Buy	<input type="checkbox"/>	Artwork
<input type="checkbox"/>	All in Service	<input type="checkbox"/>	Next Production Run	<input type="checkbox"/>	Assembly Dwg.
<input type="checkbox"/>	All in Stock	<input type="checkbox"/>		<input checked="" type="checkbox"/>	Board Artwork
Beginning Serial Number:		<input checked="" type="checkbox"/>	BOM	<input type="checkbox"/>	Control Form
Reason For Change					
Prevent fuse failure due to inrush current at turn on. An improvement to A2 which was not put into production.					
		<input checked="" type="checkbox"/>	Costing	<input type="checkbox"/>	Fab Drawing
		<input type="checkbox"/>	Inspection Proc.	<input checked="" type="checkbox"/>	Part Master File
		<input checked="" type="checkbox"/>	Schematic	<input checked="" type="checkbox"/>	Service Manual
		<input checked="" type="checkbox"/>	Test Procedure	<input type="checkbox"/>	
		<input type="checkbox"/>			
Other Affected Assemblies					
290 Assemblies , 302 Assembly (Head)					
303 Assemblies (Combo)					
<input type="checkbox"/>	Continued on ECO Supplement Page				

Description Of Change		Distribution		Date	Initials
Add NTC thermistors to the primary side of the transformer. One for 120V and another for 230V. An additional primary terminal is added to accommodate the wiring. For current production a thermistor of the proper value will be added to the bottom of the board. For 220V-240V use NTC-4R/5A. For 100V-120V use NTC-1.3R/7A.		<input type="checkbox"/>	Accounting		
		<input type="checkbox"/>	Assembly		
		<input checked="" type="checkbox"/>	Engineering		
		<input checked="" type="checkbox"/>	Incoming Q.C.		
		<input checked="" type="checkbox"/>	Production Eng.		
		<input checked="" type="checkbox"/>	Purchasing		
		<input type="checkbox"/>	Q.A.		
		<input type="checkbox"/>	Service		
		<input type="checkbox"/>	Test		
<input type="checkbox"/>	Continued on Supplement Page	<input type="checkbox"/>	Drawing(s) attached		

Part Number	Description	Parts Added		Parts Deleted	
		Qty	Ref. Designator	Qty	Ref. Designator
022-3003-0	THR NTC-1.3R/7A	1	R63		
022-3006-0	THER NTC-4R/5A	1	R64		
092-0066-0	FASTON	1	J21		

REVISION RECORD			
LTR	ECCO NO:	APPROVED:	DATE:

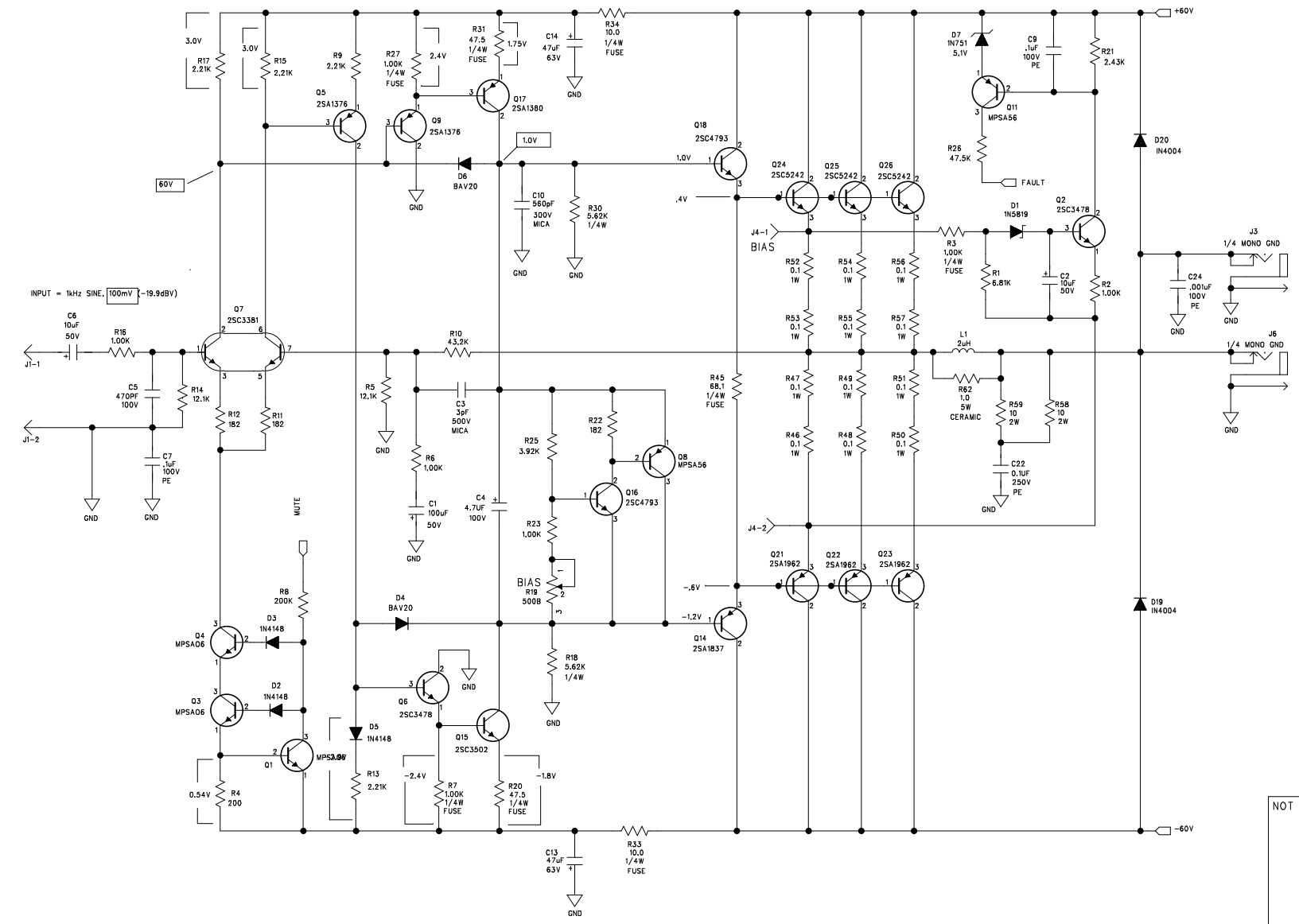
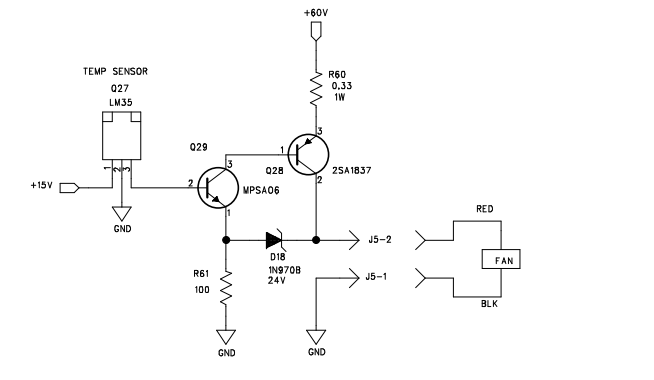
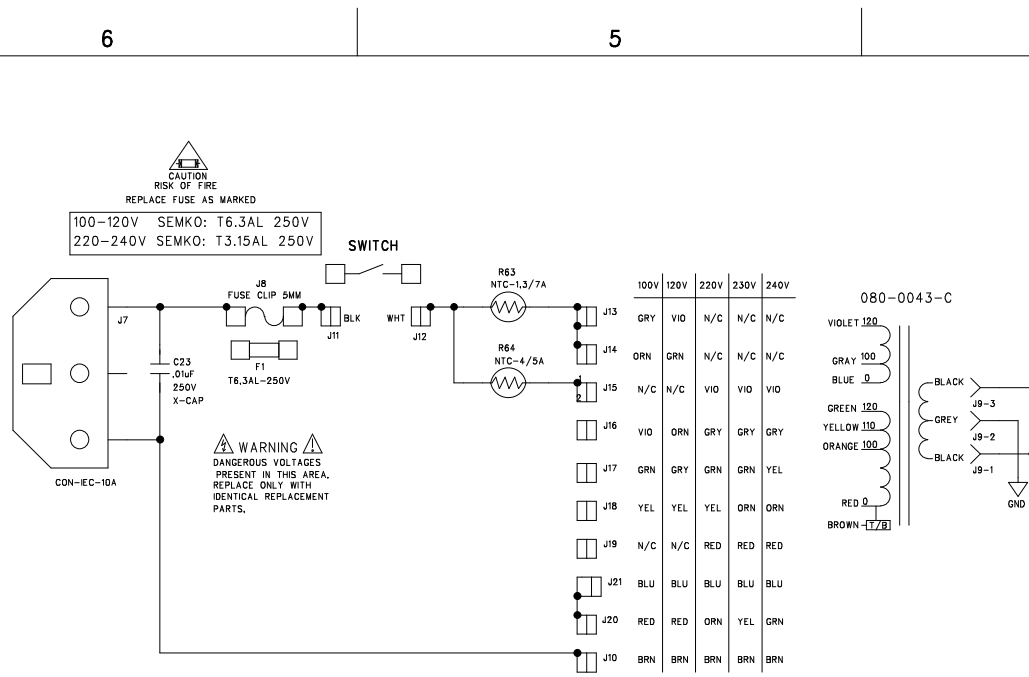
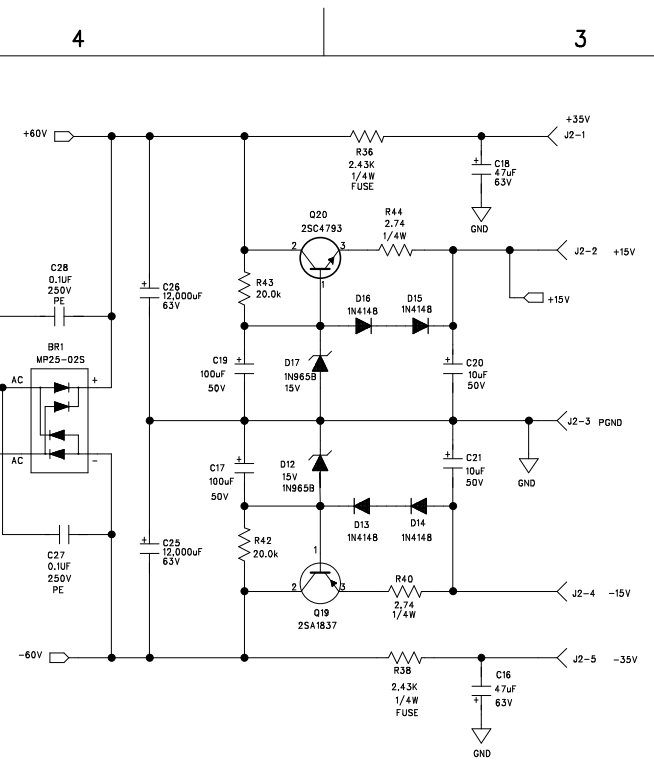
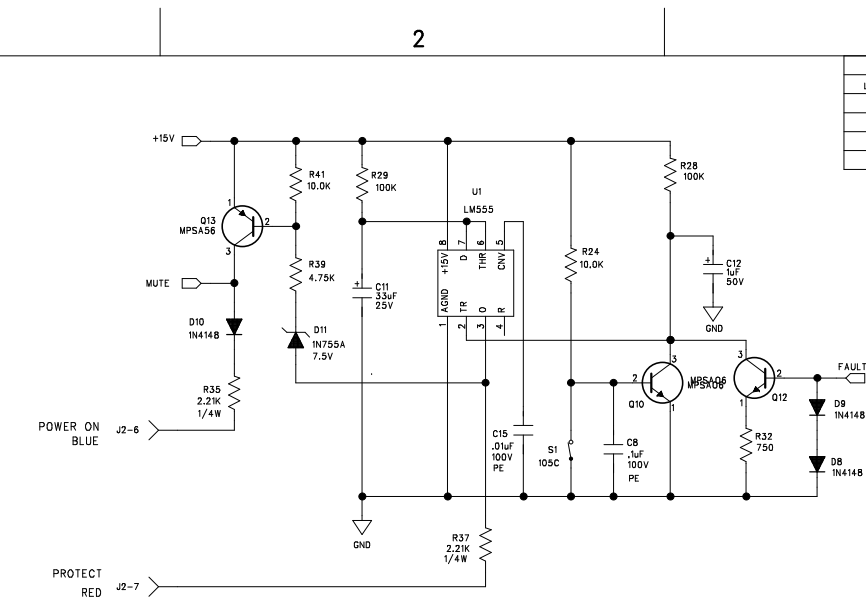

- NOTES: UNLESS OTHERWISE SPECIFIED,
1. TEST CONDITIONS: 100mV 1kHz SINE, DIRECT INPUT (PRE-AMP BYPASSED) NO LOAD
 2. DENOTES RMS AC VOLTAGE

BIAS ADJUSTMENT PROCEDURE:
 WITH POWER OFF, ADJUST POT R21 TO FULL COUNTER-CLOCKWISE POSITION.
 TURN ON POWER AND WAIT 5 SECONDS FOR TURN ON DELAY.
 TURN R21 CLOCKWISE UNTIL VOLTAGE ACROSS P3 READS 10 mVDC.

MH,200V 1 X6	MH,200V 1 X5	MH,125/220 1 X7
MH,200V 1 X4	MH,200V 1 X3	MH,125/220 1 X2
		MH,125/220 1 X1

NOT VALID UNLESS STAMP IS RED

gallien technology

2234 INDUSTRIAL DRIVE
 STOCKTON CA. 95206
 VOICE: 209-234-7300
 FAX: 209-234-8420

NOTES REV A3: 1. MODIFY SUPPLY TABLE FOR THERMISTORS 2. ADD THERMISTORS R63 AND R64. 3. ADD J15.		APPROVALS		TITLE: 400RB-IV POWER AMP
INIT	DATE	DESIGNED: R.A.G.	DATE: 11/9/99	REV. A3
DRAWN: R.A.G.	DATE: 12/10/03	DRAWING NO: 406-0240-A3		
ELEC:		PART NO: 206-0240-A3		
MECH:		COMPANY: GALLIEN KRUEGER		
Q/A:		FILENAME: 6240A3.sch		
RELEASED:				

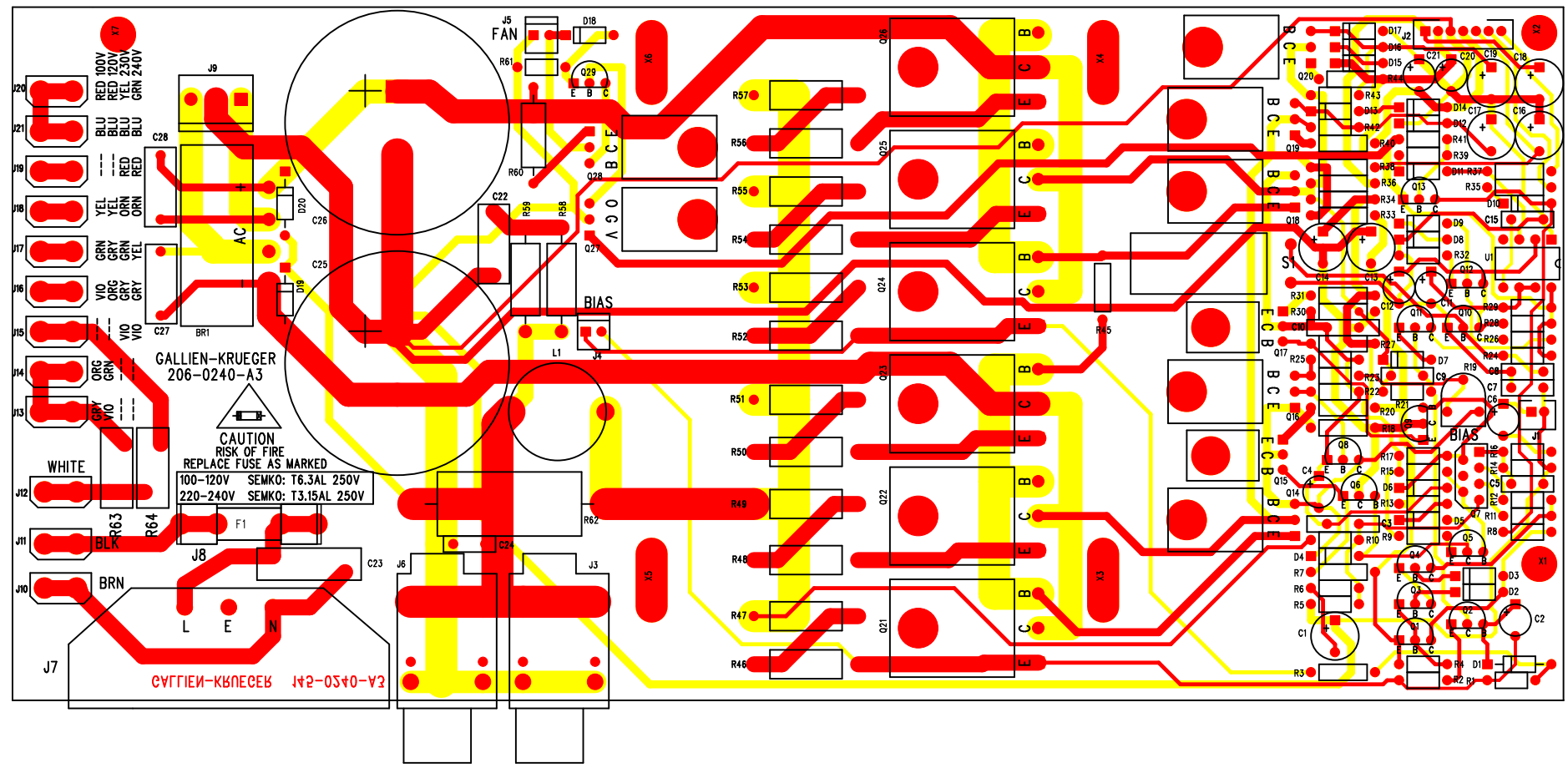

PCB WORK INSTRUCTIONS

DWG 420-0240-A3

NOTES:

UNLESS OTHERWISE SPECIFIED:

1. SQUARE PADS ON PARTS DENOTE PIN 1.
2. ALL BOARDS REQUIRE A COMPLETE VISUAL INSPECTION.
3. ALL BOARDS MUST BE BARE BOARD TESTED.
4. ASSEMBLE AND SOLDER PER ANSI/IPC-A-610B.

LOADING

5. SEE FORMING AND LOADING INSTRUCTIONS BELOW FOR INSTALLING SPECIFIED COMPONENTS.
6. CHECK THAT R45-56 ARE FLUSH WITH PCB.
7. CHECK THAT J3, 6, 7, & S1 ARE FLUSH WITH PCB.
8. MAKE CERTAIN ALL POWER TRANSISTOR MOUNTING HOLES ARE PROPERLY ALIGNED FOR HEAT SINK.

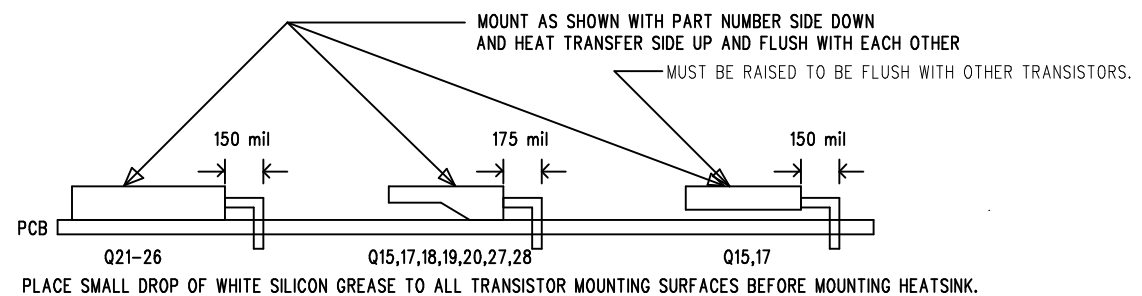

NOT VALID UNLESS STAMP IS RED		2234 INDUSTRIAL DRIVE STOCKTON CA. 95206 VOICE: 209-234-7300 FAX: 209-234-8420	
gallien technology		TITLE: 400RB-IV POWER AMP	
APPROVALS		SIZE: B	
INIT	DATE	DRAWING NO:	REV.
DESIGNED: R.A.G.	6/25/02	405-0240-A3	A3
DRAWN: R.A.G.	12/10/03	PART NO:	
ELEC:		145-0240-A3	
MECH:		COMPANY: GALLIEN-KRUEGER	
GERBER FILE NAME: sst0126.pho		FILENAME: 5240A3.PCB	
LAYER DESCRIPTION: TOP SIDE SOLDERSCREEN			

APPLY THERMAL TAPE (105-0014-0) AND ALIGN WITH THIS EDGE.

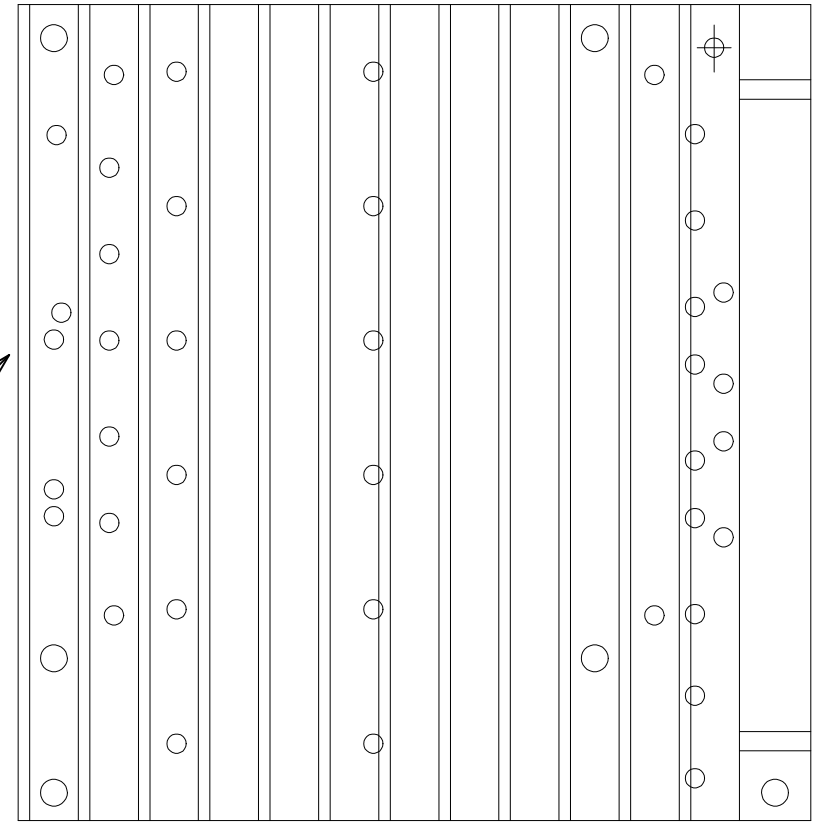

This document is generated to address fuse failure due to excessive inrush current during turn on. It is applicable to 400RB-IV power amp boards with part number 206-0240-A1. To correct the problem, a thermistor with part number 022-3006-0 is soldered in series with the primary side of the transformer.

The following is a guideline on how to modify the unit with the thermistor :

STEP I:

If the unit is a head version of 400RB-IV, remove the top cover then remove the power amp board from the chassis assembly.
 If the unit is a combo version of 400RB-IV, remove the chassis assembly from the cabinet, then remove the power amp board. Please see figure 1.



Chassis Assembly
figure 1

power amp board

STEP II:

Locate J13 and J12 on the power amp board (figure 2a). Turn the power amp board over as per figure 2b.

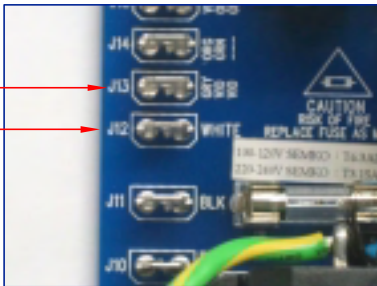
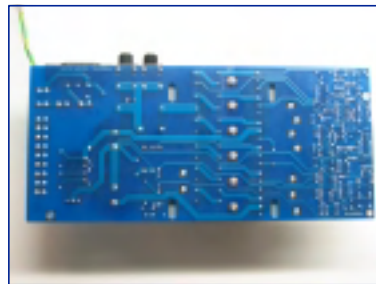

figure 2a



Power Amp Board
figure 2b

STEP III:

Locate J12 and J13 on the bottom/solder side of the board (figure 3a). Cut the trace between J12 and J13 as shown in figure 3b.

location of J12 and J13 on the bottom/solder side of the board

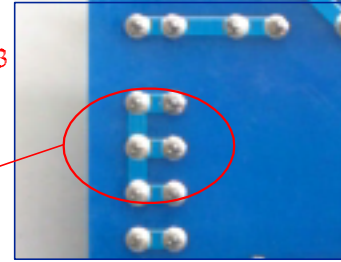

figure 3a

cut the trace here

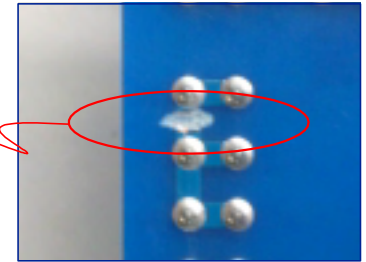

figure 3b

STEP IV:

Solder one lead of Thermistor (022-3006-0) to J12 and the other to J14 on the bottom/solder side of the power amp board, as shown in figure 4.

Note: Make sure that no portion or part of the thermistor is touching any terminal on the board except terminals J12 and J14.

Thermistor NTC 4 ohms, 5 amperes
 P.N: 022-3006-0
 for 400RB-IV power amp board

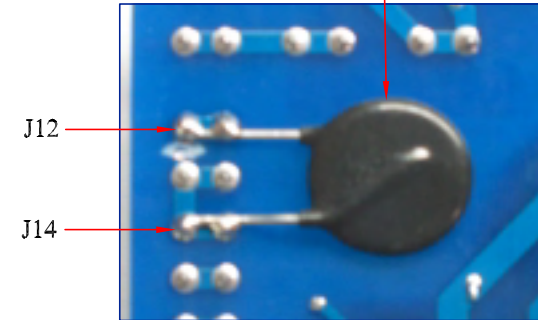

figure 4

PROPRIETARY		
THE DRAWING CONTAINS INFORMATION WHICH IS PROPRIETARY TO GALLIEN TECHNOLOGY CORPORATION. DO NOT REPRODUCE IN ANY FORM OR DISTRIBUTE IN ANY FASHION WITHOUT THE EXPRESS WRITTEN PERMISSION OF GALLIEN TECHNOLOGY CORPORATION.		
APPROVAL		
DEPT.	INITIAL	DATE
PRODUCTION	NOLLYALDRZ	12/18/2003

gallien technology 2234 INDUSTRIAL DRIVE STOCKTON, CA, 95207	
TITLE THERMISTOR MODIFICATION	
FILE NAME	REV.
DOCUMENT NUMBER	SIZE
SCALE	SHEET
NOT TO SCALE	1 OF 1