

Stereophonic

THE FISHER LIVING THEATRE SERVICE MANUAL

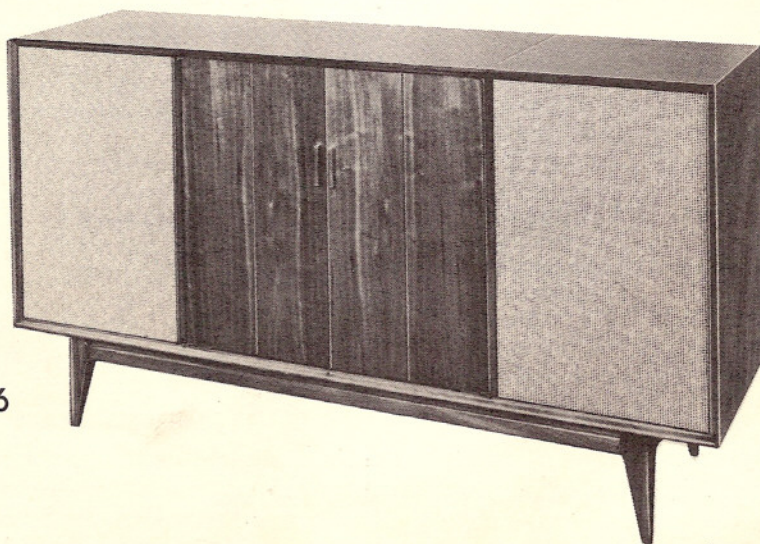

MODEL TV-66

PRICE: \$1.00

FISHER RADIO CORPORATION • NEW YORK

(c) www.fisherconsoles.com

Handwritten signature

THE FISHER TV-66

Handwritten signature

DISASSEMBLY INSTRUCTIONS

1 FM-AM TUNER-CONTROL CHASSIS

- Remove all knobs from top panel.
- Loosen rear screw, in angled slot of supporting cleat attached to the floor of the tuner compartment.
- Pull the supporting cleat toward the back of the cabinet.
- Remove all electrical connections.
- Slide out chassis through the top.

2 TV TUNER CHASSIS

- Remove the wooden top panel by detaching the eight wood screws.
- Remove the peg board on the floor of the compartment with the four wood screws.
- Remove the two screws at the ends of the two angle irons supporting the TV tuner.
- Remove the two outer screws on both flanges of the TV tuner.
- While holding the tuner chassis firmly, remove the angle irons from the top.
- Tilt the bottom of the tuner chassis toward the rear, and remove the tuner through the rear opening.

3 REMOTE CONTROL CHASSIS

- Remove the TV tuner chassis as described in the previous section.
- Remove electrical connections.
- Detach the two Phillips head screws holding the chassis to the compartment floor.
- Remove the chassis through the rear opening.

PARTS DESCRIPTION LIST • AMPLIFIER

CAPACITORS

10 % tolerance for all fixed capacitors, unless otherwise noted or marked GMV (guaranteed minimum value.)

Symbol	Description	Part No.
C91, 92	Ceramic, 3uuf, NPO, 1000V	C50070-28
C93	Electrolytic, 3 section	C50180-17
	A — 100uf 100V	
	B — 60uf 250V	
	C — 60uf 250V	
C94, 95		
96, 97	Mylar, .047uf, 400V	C50197-30
C98	Electrolytic, 3 section	C50180-23
	A — 40uf 450V	
	B — 40uf 450V	
	C — 100uf 250V	
C99	Ceramic, 18uuf, N470, 1000V	C50070-13
C100	Ceramic, 150uuf, 1000V	C50072-18
C101	Ceramic, 18uuf, N470, 1000V	C50070-13
C102	Ceramic, 150uuf, 1000V	C50072-18
C103	Electrolytic, 100uf, 250V	C50180-15
C104, 105	Ceramic, 330uuf, 1000V	C50072-1
C106, 107	Molded, .01uf, 20 %, 600V	C2747

R98	Composition, 680K	RC20BF684K
R99	Dep. Carbon, 3.9K, 5 %, 1/3 W	R33DC392J
R100	Dep. Carbon, 220, 5 %, 1/3 W	R33DC221J
R101	Composition, 680K	RC20BF684K
R102	Dep. Carbon, 3.9K, 5 %, 1/3 W	R33DC392J
R103	Dep. Carbon, 220, 5 %, 1/3 W	R33DC221J
R104	Composition, 18K	RC20BF183K
R105, 106,		
107, 108	Dep. Carbon, 47K, 5 %, 1/3 W	R33DC473J
R109	Potentiometer, 5K, bias control	R50103-4
R110	Composition, 2.7K	RC20BF272K
R111, 112	Composition, 220	RC20BF221K
R113	Dep. Carbon, 2.7K, 5 %, 1/3 W	R33DC272J
R114, 115	Dep. Carbon, 330K, 5 %, 1/3 W	R33DC334J
R116, 117,		
118	Dep. Carbon, 2.7K, 5 %, 1/3 W	R33DC272J
R119, 120	Dep. Carbon, 330K, 5 %, 1/3 W	R33DC334J
R121, 122	Dep. Carbon, 2.7K, 5 %, 1/3 W	R33DC272J
R123	Composition, 2.7K, 1W	RC30RF272K
R124	Wirewound, 220, 5W	R551-137
R125	Composition, 4.7K	RC20BF472K
R126	Wirewound, 2.2K, 7W	R563-148
R127	Wirewound, 220, 5W	R551-137

MISCELLANEOUS

Symbol	Description	Part No.
R96, 97	Composition, 68K, 5 %	RC20BF683J

Symbol	Description	Part No.
CR, 3, 4	Silicon Diode, SD95A	SR806-126
T1	Transformer, Output Channel A	T812-217-1
T2	Transformer, Output Channel B	T812-217-2
T3	Transformer, Power	T812-215
F1	Fuse, 3.2 amp, Slo-blo	F3319

SCHEMATIC DIAGRAM • AMPLIFIER

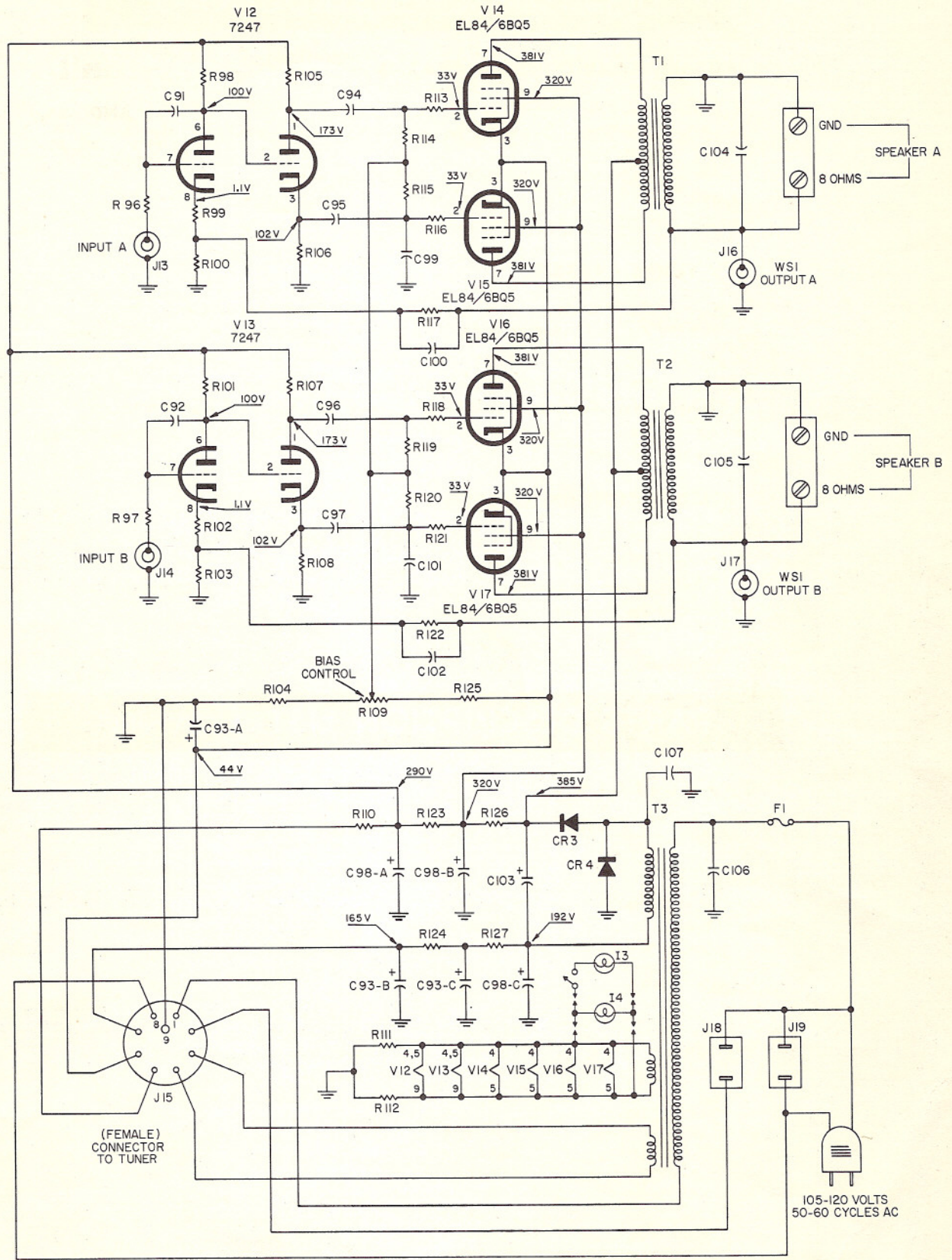

AW # 1779A
P 812 • SCHEMATIC
SHEET 2 OF 2

RESISTORS	R96 R97	R98 TO R103	R104	R105 TO R108	R109 TO R112	R113 TO R124	R125 R126 R127			
CAPACITORS	C91 C92	C93-A		C94 TO C97	C98-A TO C93-B	C99 TO C102	C98 B TO C93-C	C103 C98-C	C107	C104 C105 C106

PARTS DESCRIPTION LIST • TUNER AND PREAMPLIFIER

CAPACITORS

10% tolerance for all fixed capacitors, unless otherwise noted or marked GMV (guaranteed minimum value.)

Symbol	Description	Part No.
C1, 2	Ceramic, 100uf, GMV, 1000V	C50070-5
C3	Ceramic, 21uf, 5%, N750, 1000V	C50070-32
C4	Ceramic, 3uf, NPO, 1000V	C50070-28
C5	AM, variable	C812-118
C6	Ceramic, .001uf, GMV, 1000V	C50071-2
C7	Ceramic, feedthru, .001uf, GMV	C592-187
C8	Ceramic, .02uf, +80 -20%, 500V	C50089-4
C9	Ceramic, 100uf, GMV, 1000V	C50070-5
C10, 11	Ceramic, .01uf, 20%, 500V	C50089-3
C12	Ceramic, feedthru, .001uf, GMV	C592-187
C13, 14	Ceramic, .02uf, +80 -20%, 500V	C50089-4
C15, 16	Mylar, .022uf, 400V	C50197-28
C17	Ceramic Trimmer	C662-123
C18	FM, variable	C818-116
C19	Ceramic, 2.2uf, 500V	C3039
C20	Ceramic, .001uf, GMV, 1000V	C50071-2
C21	Ceramic, 8uf, ±.5uf, NPO, 500V	CC20CJ080D5
C22	Ceramic, 5uf, NPO, 1000V	C50070-24
C23	Ceramic, 33uf, 5%, N750, 1000V	C50070-25
C24	Ceramic, 100uf, GMV, 1000V	C50070-5
C25	Ceramic, 24uf, 5%, N150, 1000V	C50070-8
C26	Ceramic, 47uf, 5%, N750, 1000V	C50070-29
C27	Ceramic, 8uf, ±.5uf, NPO, 500V	CC20CJ080D5
C28	Ceramic, 100uf, 5%, N1500, 1000V	C50070-19
C29	Ceramic, 10uf, ±.5uf, N150, 500V	CC20PJ100D5
C30	Ceramic, .001uf, 1000V	C50072-3
C31, 32	Ceramic, .005uf, 20%, 500V	C50089-1
C33, 34	Ceramic, .05uf, +80, -20%, 100V	C50073-2
C35	Ceramic, 100uf, GMV, 1000V	C50070-5
C36	Ceramic, 10uf, NPO, 1000V	C50070-11
C37, 38	Ceramic, 39uf, N1500, 1000V	C50070-17
C39	Ceramic, .005uf, 20%, 500V	C50089-1
C40	Ceramic, .68uf, 500V	C50077-6N
C41	Ceramic, .02uf, +80, -20%, 500V	C50089-4
C42, 43	Ceramic, .02uf, 20%, 500V	C50089-5
C44	Ceramic, .0027uf, 1000V	C50072-17
C45	Ceramic, .005uf, 20%, 500V	C50089-1
C46	Ceramic, .68uf, 500V	C50077-6N
C47	Ceramic, .02uf, +80, -20%, 500V	C50089-4
C48, 49, 50	Ceramic, .005uf, 20%, 500V	C50089-1
C51	Ceramic, .0039uf, 1000V	C50072-34
C52	Ceramic, .0027uf, 1000V	C50072-17
C53	Ceramic, .005uf, 20%, 500V	C50089-1
C54	Ceramic, 100uf, N1500, 1000V	C50070-6
C55	Mylar, .047uf, 250V	C50197-52
C56	Ceramic, .005uf, 20%, 500V	C50089-1
C57	Ceramic, 820uf, 1000V	C50072-7
C58	Ceramic, 47uf, N750, 1000V	C50070-4
C59	Ceramic, .005uf, 20%, 500V	C50089-1
C60	Ceramic, 820uf, 1000V	C50072-7
C61	Ceramic, 47uf, N750, 1000V	50070-4
C62, 63	Ceramic, .0015uf, 1000V	C50072-10
C64	Ceramic, 82uf, N1500, 1000V	C50070-7
C65	Ceramic, .02uf, 20%, 500V	C50089-5
C66	Ceramic, 82uf, N1500, 1000V	C50070-7
C67	Ceramic, .02uf, 20%, 500V	C50089-5
C68	Ceramic, .0027uf, 1000V	C50072-17
C69	Ceramic, .005uf, 20%, 500V	C50089-1
C70	Ceramic, 330uf, 1000V	C50072-1

C71	Ceramic, .0033uf, 1000V
C72	Electrolytic, two sections A — 20uf 300V B — 40uf 400V
C73, 74	Ceramic, 330uf, 1000V
C75	Ceramic, .05uf, +80, -20%, 100V
C76	Ceramic, .005uf, 20%, 500V
C77	Ceramic, .005uf, 20%, 500V
C78	Ceramic, .01uf, 20%, 500V
C79	Ceramic, .005uf, 20%, 5000V
C80	Ceramic, feedthru, .001uf, GMV
C81	Electrolytic, 8uf, 50V
C82	Ceramic, .005uf, 20%, 500V
C83	Ceramic, .01uf, 20%, 500V
C84	Ceramic, .005uf, 20%, 500V
C85	Ceramic, feedthru, .001uf, GMV

C50072-11
C50180-22
C50072-1
C50073-2
C50089-1
C50089-1
C50089-3
C50089-1
C529-187
C629-138
C50089-1
C50089-3
C50089-1
C529-187

R56	Composition, 150
R57	Composition, 27K
R58	Composition, 180K
R59	Composition, 180K
R60	Composition, 821K
R61, 62	Composition, 220K
R63	Composition, 47K
R64	Composition, 2.2M
R65	Composition, 100K
R66	Composition, 560
R67	Composition, 390K, 5%
R68	Composition, 100K
R69	Composition, 560
R70	Composition, 390K, 5%
R71	Composition, 1K

RC20BF151K
RC20BF273K
RC20BF102K
RC20BF184K
RC20BF823K
RC20BF224K
RC20BF473K
RC20BF225K
RC20BF104K
RC20BF561K
RC20BF394J
RC20BF104K
RC20BF561K
RC20BF394J
RC20BF102K

RESISTORS AND POTENTIOMETERS

In ohms, 10% tolerance, 1/2 watt, unless otherwise noted; K=kilohm, M=Megohm.

Symbol	Description	Part No.
R1	Composition, 270	RC20BF271K
R2, 3	Dep. Carbon, 270K, 5%, 1/2 W	R33DC274J
R4, 5	Dep. Carbon, 120K, 5%, 1/2 W	R33DC124J
R6	Dep. Carbon, 47K, 5%, 1/2 W	R33DC473J
R7	Composition, 10	R33DC473J
R8	Dep. Carbon, 47K, 5%, 1/2 W	R33DC473J
R9	Composition, 10	RC20BF100K
R10	Dep. Carbon, 10K, 50%, 1/2 W	R33DC103J
R11	Dep. Carbon, 2.7K, 5%, 1/2 W	R33DC272J
R12	Dep. Carbon, 10K, 5%, 1/2 W	R33DC103J
R13	Dep. Carbon, 2.7K, 5%, 1/2 W	R33DC272J
R14	Composition, 100K	RC20BF104K
R15	Composition, 1.5M	RC20BF155K
R16	Composition, 820K	RC20BF824K
R17, 18	Dep. Carbon, 330K, 5%, 1/2 W	R33DC334J
R19	Composition, 100	RC20BF101K
R20, 21	Composition, 4.7M	RC20BF475K
R22	Composition, 470	RC20BF471K
R23, 24	Dep. Carbon, 220K, 5%, 1/2 W	R33DC224J
R25	Composition, 47K	RC20BF473K
R26, 27	Dep. Carbon, 330K, 5%, 1/2 W	R33DC334J
R28	Composition, 820	RC20BF821K
R29	Composition, 820K	RC20BF824K
R30	Composition, 150K	RC20BF154K
R31	Dep. Carbon, 22K, 5%, 1/2 W	R33DC223J
R32, 33	Composition, 1K	RC20BF102K
R34	Composition, 18K, 1W	RC30BF183K
R35	Composition, 100	RC20BF101K
R36	Dep. Carbon, 470K, 5%, 1/2 W	R33DC474J
R37	Composition, 5.6M	RC20BF565K
R38	Dep. Carbon, 470K, 5%, 1/2 W	R33DC474J
R39	Composition, 5.6M	RC20BF565K
R40, 41	Composition, 2.2M	RC20BF225K
R42	Composition, 100K	RC20BF104K
R43	Composition, 560	RC20BF561K
R44	Composition, 100K	RC20BF104K
R45	Composition, 560	RC20BF561K
R46	Composition, 150	RC20BF151K
R47, 48	Composition, 220K	RC20BF224K
R49	Composition, 47K	RC20BF473K
R50	Composition, 1K	RC20BF102K
R51	Composition, 180	RC20BF181K
R52	Potentiometer, dual, 1M, treble	R50160-55
R53	Potentiometer, dual, 1M bass	R50160-55
R54, 55	Composition, 39K	RC20BF393K

R72, 73, 74	Composition, 2.2M
R75, 76	Composition, 5.6M
R77	Composition, 47K
R78	Potentiometer, dual, 300K, balance
R79, 80	Dep. Carbon, 22K, 5%, 1/2 W
R81	Composition, 68K
R82	Potentiometer, dual, 500K, volume
R83	Composition, 1K
R84	Composition, 270
R85	Dep. Carbon, 22K, 5%, 1/2 W
R86	Composition, 100K
R87	Composition, 22K
R88	Composition, 1.5K
R89	Composition, 1K
R90	Composition, 15K
RC20BF225K	
RC20BF565K	
RC20BF473K	
R50160-56	
R33DC225J	
RC20BF683K	
R50160-54	
RC20BF102K	
RC20BF271K	
R33DC223J	
RC20BF104K	
RC20BF223K	
RC20BF152K	
RC20BF102K	
RC20BF153K	

COILS, CHOKES AND TRANSFORMERS

Symbol	Description	Part No.
L1	AM Loop	L50210-26
L2	FM Ant. Coil	L818-113
L3	Choke, R.F., 1.5 Micro Henries	L50066-4
L4	Choke	L629-180
L5	FM, RF Coil	L818-114
L6	FM Osc. Coil Assembly	AS818-118
L7	Choke, R.F., .68 Micro Henries	L50066-1
L8	Choke, R.F., .2 Micro Henries	L50066-2
L9	AM Osc. Coil	L50210-22
L10, 11, 12, 13, 14, 15, 16, 17	Choke Fil., Ferrite Bead	L592-189
Z1	FM, IF Transformer	ZZ662-117
Z2	FM, IF Transformer	ZZ2987
Z3	FM Lim. Coil Assembly	L670-145
Z4	FM Det. Transformer	ZZ592-170
Z5	AM, RF Transformer	L50210-23
Z6, Z7	AM, IF Transformer	ZZ2984

MISCELLANEOUS

Symbol	Description	Part No.
CR1, CR2	Diode, matched pair	V-1N542
PC1, PC2	Printed Circuit Phono Equalization	PC50187-3
PC3, PC4	Printed Circuit Tone Control	PC50187-4
I1, I2	Dial Lamp	I50082-7
S1	Switch Selector	C812-119
S2	Switch, power	Part of R82
S3	Switch, slide	S50200-2
	Dial, glass	N812-126
	Knob, FM and AM tuning	E50108-3
	Knob	E50108-2

SCHEMATIC DIAGRAM • TUNER AND PREAMPLIFIER

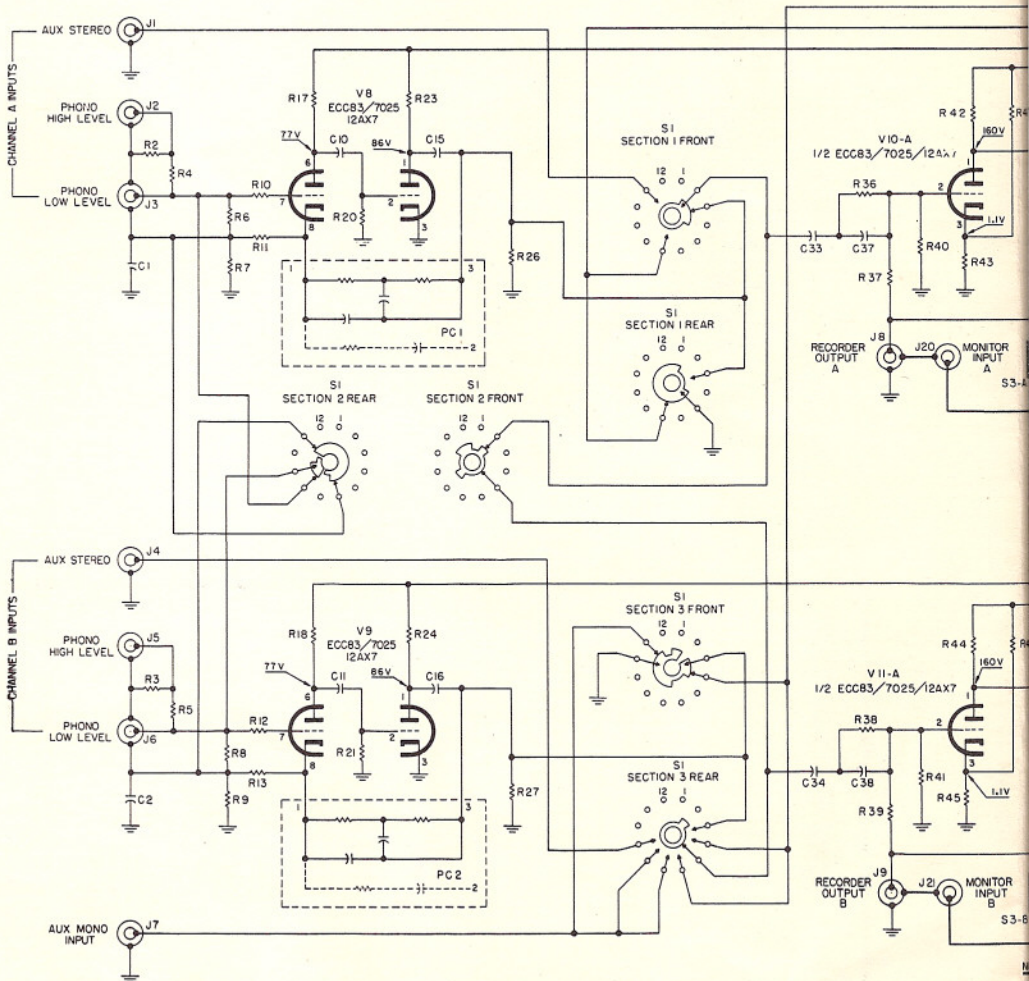
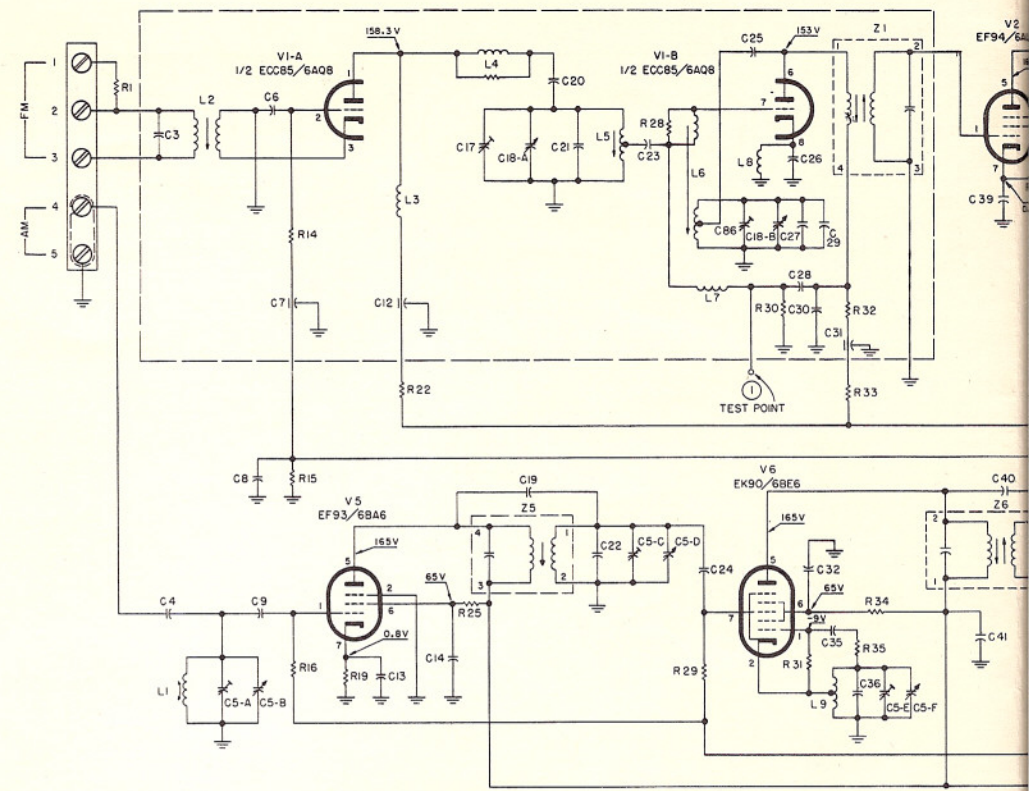

RESISTORS	R1	R2	R3	R4	R5	R6	R7	R8	R9	R10	R11	R12	R13	R14	R15	R16	R17	R18	R19	R20	R21	R22	R23	R24	R25	R26	R27	R28	R29	R30	R31	R32	R33	R34	R35	R36	R37	R38	R39	R40	R41	R42	R43	R44	R45		
CAPACITORS	C1	C2	C3	C4	C5-A	C5-B	C5-C	C5-D	C5-E	C5-F	C6	C7	C8	C9	C10	C11	C12	C13	C14	C15	C16	C17	C18-A	C18-B	C19	C20	C21	C22	C23	C24	C25	C26	C27	C28	C29	C30	C31	C32	C33	C34	C35	C36	C37	C38	C39	C40	C41

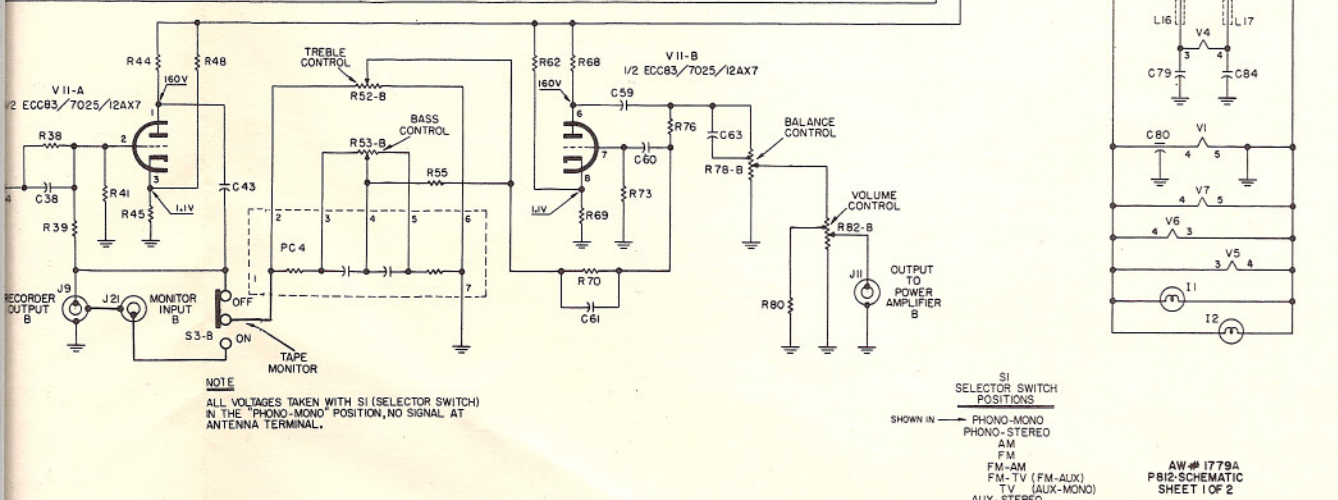
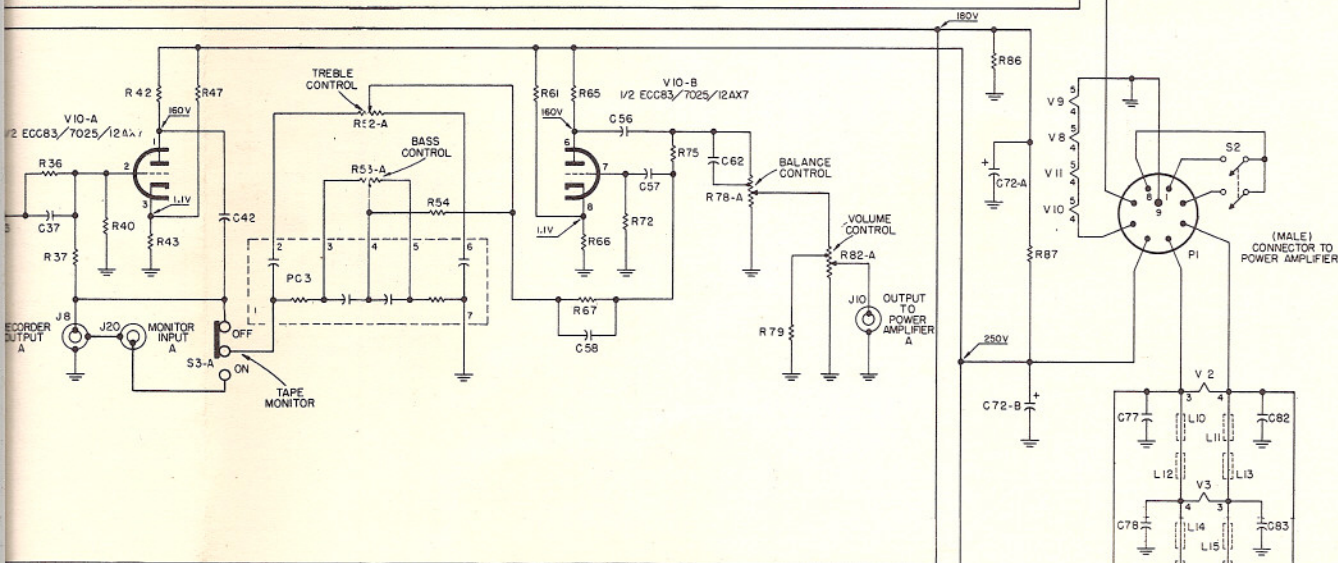
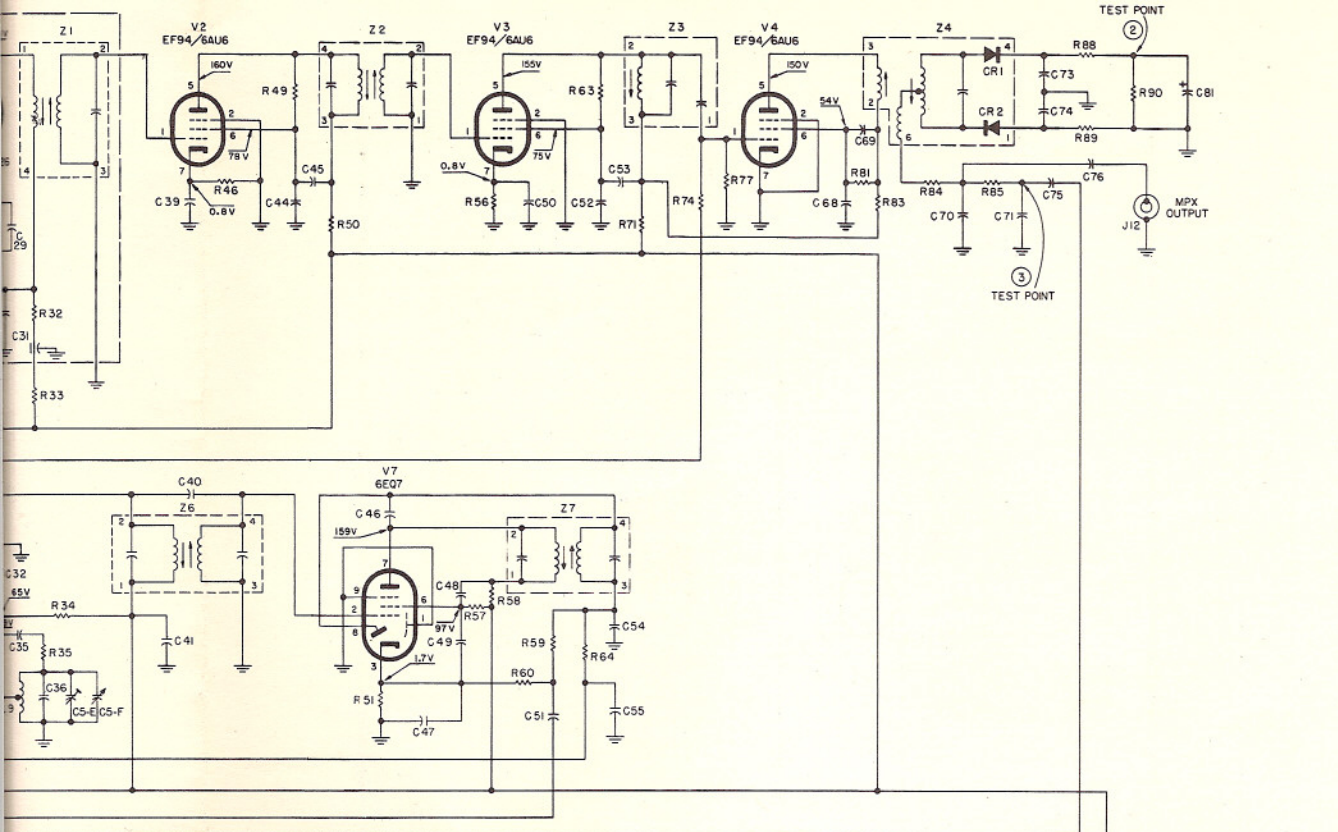

NOTE
ALL VOLTAGES TAKEN WITH SI (SELECTOR SWITCH)
IN THE 'PHONO-MONO' POSITION, NO SIGNAL AT
ANTENNA TERMINAL.

SI
SELECTOR SWITCH
POSITIONS
SHOWN IN — PHONO-MONO
PHONO-STEREO
AM
FM
FM-AM
FM-TV (FM-AUX)
TV (AUX-MONO)
AUX-STEREO

AW # 1779A
PB12-SCHEMATIC
SHEET 1 OF 2

R32 TO R34	R40 TO R45	R42 TO R48	R46 TO R47	R49	R50 TO R55	R54 TO R58	R56 TO R58	R59 TO R62	R63 TO R70	R71 TO R73	R74 TO R76	R78-A TO R77	R79 TO R80	R81 TO R82-A	R83 TO R82-B	R84 TO R86	R85 TO R87	R88 TO R89	R90	
C26 TO C34	C35 TO C38	C5-E TO C5-F	C39 TO C41	C42 TO C43	C44 TO C45	C46 TO C49	C48 TO C49	C50 TO C51	C52 TO C51	C52 TO C51	C63	C68 TO C69	C70	C71 TO C72-A	C72-B	C73 TO C75	C76	C77 TO C80	C79 TO C81	C82 TO C84

ALIGNMENT INSTRUCTIONS

Read These Instructions With Extreme Care Before Attempting Alignment.

CHASSIS: Turn the station selectors completely counterclockwise, without forcing. Dial pointers should be at zero index mark on logging scale. If not, reset the dial pointers. Disconnect the external antennas and the antenna link. Set Ferrite Loop to normal position, parallel to rear panel. Set Volume Control to minimum (CCW.)

When using an oscilloscope for alignment, set the output level controls for no overload, as shown by the proper waveform shape.

SIGNAL GENERATORS: The signal generator equipment must be able to supply the following:

FM RF modulated 30% (± 22.5 KC deviation) at 400 cps; AM RF modulated 30% at 400 cps;

INDICATOR: DC VTVM, AC VTVM, and scope for alignment.

ALIGNMENT: Allow the chassis and test instruments to warm up for at least fifteen minutes. Adjust the line voltage for 117 volts AC, 50-60 cycles. Use fully insulated tools: a small screwdriver for all trimming capacitors; a K-Tran tool for Z1, Z2, Z5, Z6 and Z7; a hex tool for Z3, Z4, L2, L5, L6 and L9. For AM alignment, short junction of C55 and R64 to ground.

AM ALIGNMENT

STEPS	CHASSIS		SIGNAL GENERATOR			INDICATOR		ALIGNMENT	
	SELECTOR	STATION SELECTOR	COUPLING	FREQ.	MOD.	TYPE	CONNECTION	ADJUST	INDICATION
1	AM	Point of no signal and no interference	AM Gen. connected thru .01-uF cap. to V6, Pin 7	455 KC	30% AM at 400 cps	AC VTVM to Ch. B	RCRDR Output	Z6, Z7 top and bottom	Maximum voltage
2	AM	600 KC	AM Gen. connected thru 220-uF cap. to antenna terminal 4 Disconnect link between 4 & 5	600 KC	30% AM at 400 cps	AC VTVM to Ch. B	RCRDR Output	L9, Z5 L1	Maximum voltage
3	AM	1400 KC	AM Gen. connected thru 220-uF cap. to antenna terminal 4 Disconnect link between 4 & 5	1400 KC	30% AM at 400 cps	AC VTVM to Ch. B	RCRDR Output	C5E, C5C C5A	Maximum voltage
4	Repeat steps 2 and 3 for proper dial calibration and maximum output.								
5	FM	Point of no signal and no interference	FM Gen. connected thru 2.2-uF cap. to test point 1	10.7 MC	None	DC VTVM to test point 2		Z1, Z2, Z3 and Z4, top & bottom	Maximum positive voltage
6	FM	Point of no signal and no interference	FM Gen. connected thru 2.2-uF cap. to test point 1	10.7 MC	None	Connect two 47K ohm resistors in series across C81. Connect a VTVM between the junction of the two 47K ohm resistors and test point 3		Z4 top	Zero reading on zero center scale
7	FM	90 MC	FM Gen. connected thru two 120-ohm carbon resistors to antenna terminals 2 and 3	90 MC	30% FM (22.5 KC Dev.) at 400 cps	DC VTVM to test point 2 and scope to Ch. A	RCRDR Output	L6, L5, L2	Check for sine waveform and adjust for maximum positive voltage
8	FM	106 MC	FM Gen. connected thru two 120-ohm carbon resistors to antenna terminals 2 and 3	106 MC	30% FM (22.5 KC Dev.) at 400 cps	DC VTVM to test point 2 and scope to Ch. A	RCRDR Output	C86 and C17	Check for sine waveform and adjust for maximum positive voltage
9	Repeat steps 7 and 8 at least once for proper dial calibration and maximum output.								
NOTE: For calibrating both the AM and FM, use as low an output voltage as possible from your signal generator.									

FM ALIGNMENT

TUBE LAYOUT

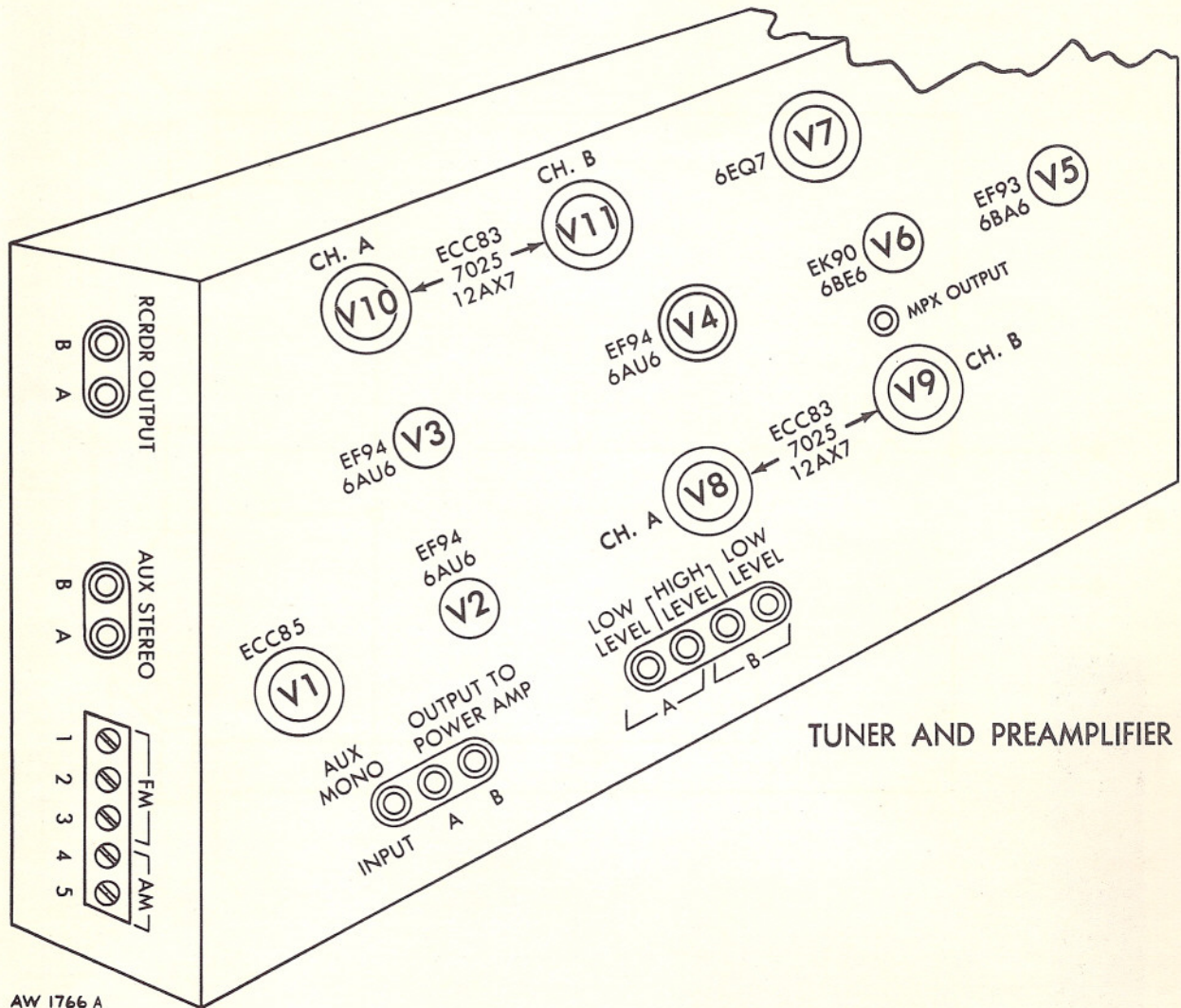

AW 1766 A

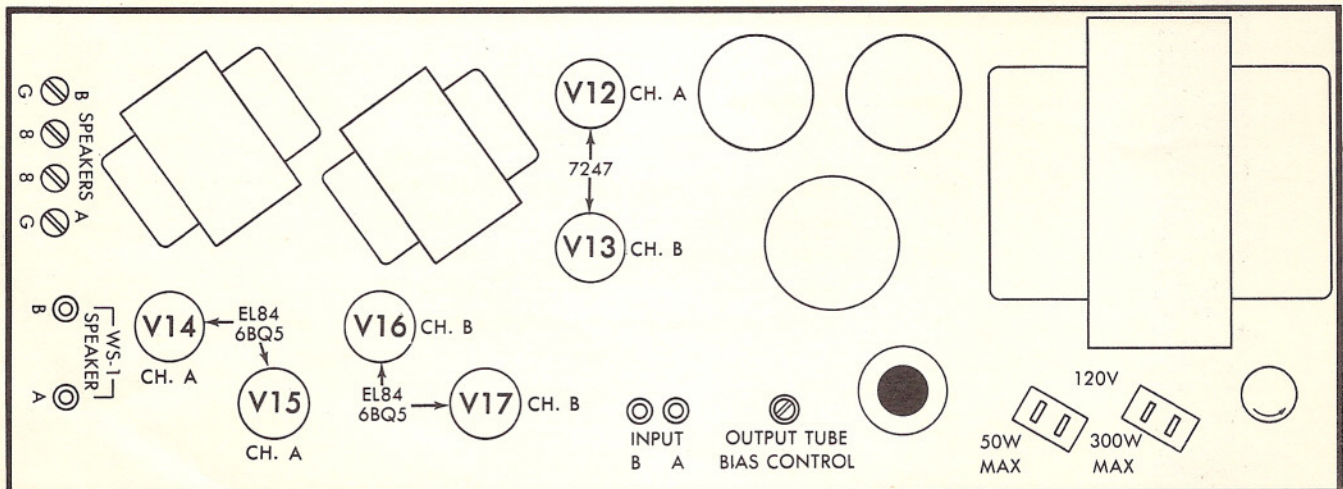

AW 1762

SCHEMATIC DIAGRAM • SPEAKER SYSTEMS

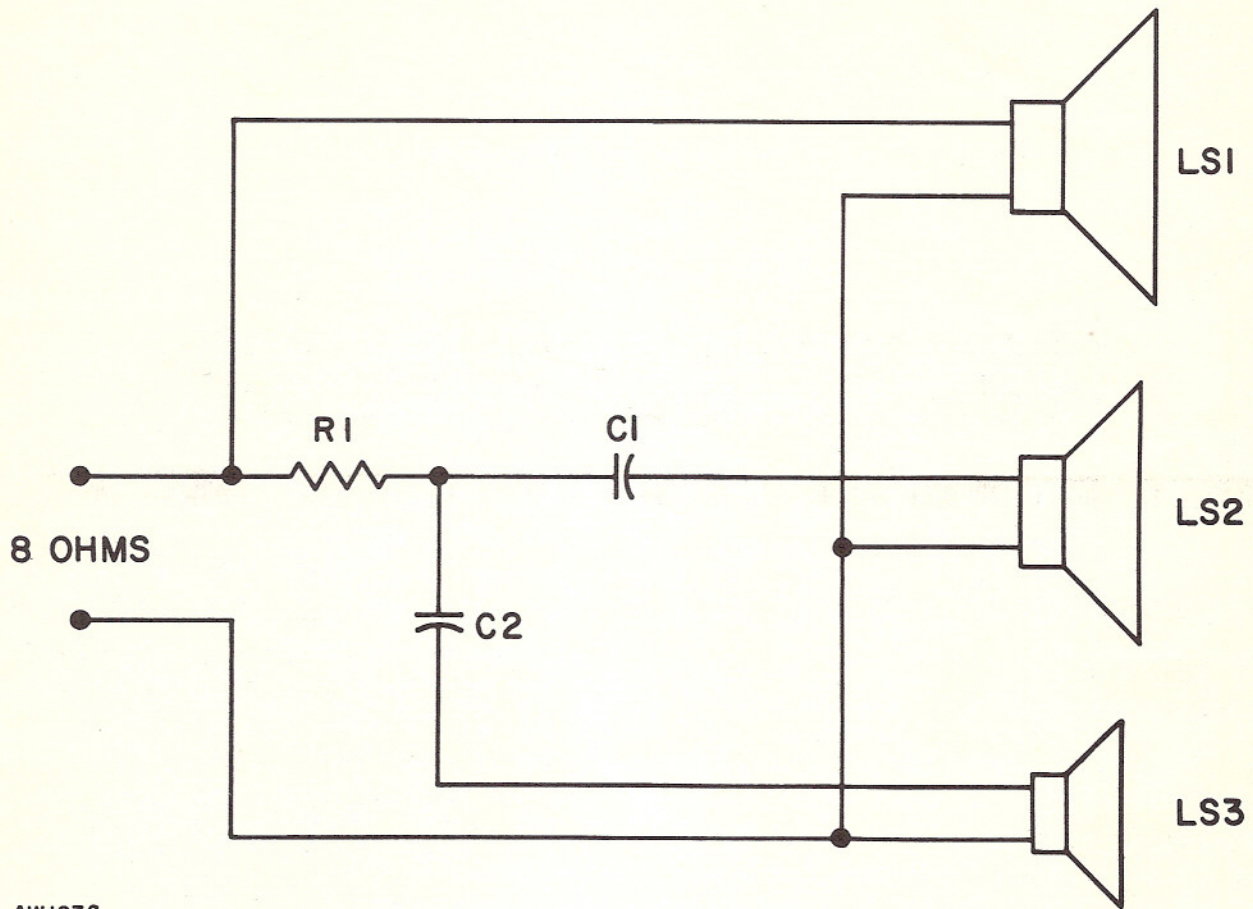

AW1836

PARTS DESCRIPTION LIST • SPEAKER SYSTEMS

Symbol	Description	Part No.
C1	Capacitor, electrolytic, non-polarized, 5uf, 20%, 50V	C769-105
C2	Capacitor, mylar, .68uf, 10%, 250V	C50197-57
LS1	Speaker, woofer, 10-inch, 8 ohms	LS835-107
LS2	Speaker, mid-range, oval	LS830-106
LS3	Speaker, tweeter	LS830-107
R1	Resistor, wirewound, 6.8 ohms, 10%, 5W	R671-113

CHANGES TO TV SCHEMATIC

- 1 — The arm of potentiometer, R-107, is disconnected from the grid (Pin 2) of V-3. The audio signal is taken from the arm of R-107.
- 2 — Pin 2 of V-3 is grounded.
- 3 — The picture tube, V-11, has been changed to a 23CP4.
- 4 — The speaker system has been omitted.
- 5 — C-30 in the VHF tuner has been changed to a value of 22uuf.

TV ADJUSTMENTS • REAR PANEL

HORIZONTAL HOLD — Stops horizontal movement (diagonal bars).

BRIGHTNESS — Adjusts for desired picture brilliance.

VERTICAL HOLD — Stops upward or downward picture movement.

RANGE SELECTOR CONTROL (AGC) — Turn this control completely counter-clockwise. From this position adjust the control clockwise until a minimum amount of snow and best possible picture can be obtained without bending or distortion (overloading).

ADJUSTMENT OF SYNC STABILITY CONTROL — When receiving strong (500 MV or more) signals, set hold controls

so that the picture is locked in. Turn the sync control slowly clockwise until bending or sync instability occurs. Then turn the control slightly counter-clockwise until bending or sync instability disappears. If the control is set incorrectly, bending, tearing etc., will be present and when switching from channel to channel the picture will not lock in quickly. In weak signal areas the control should be set for maximum picture stability. In general, the weaker the signal, the more clockwise the control should be turned. When the sync stability control is correctly adjusted the receiver will hold sync without tearing or rolling under even the most adverse noise conditions.



FISHER RADIO CORPORATION • NEW YORK

N835-103

Printed in U.S.A.

129W5C-21

(c) www.fisherconsoles.com