

# THE FISHER

RADIO PHONOGRAPH

SERVICE INSTRUCTIONS

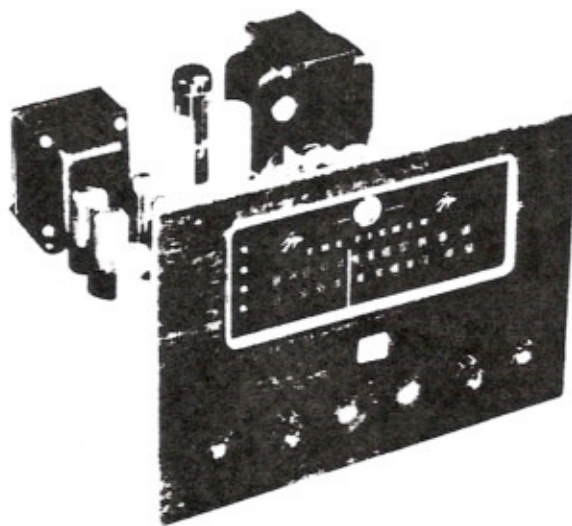

CUSTOM ELECTRA • SERIES K-14

PRICE: \$100

FISHER RADIO CORPORATION • NEW YORK

# THE FISHER

CUSTOM ELECTRA • SERIES K-14

## THE FISHER Z-MATIC CONTROL

The loudspeaker system has long been recognized as one of the most important limiting factors in the faithful reproduction of high fidelity sound. Where a loudspeaker bears the typical specification — "Voice Coil Impedance: 16 ohms" — it should be noted that this specification really applies only to a *limited portion* of the total frequency range. The reason is that a speaker voice coil impedance actually varies quite markedly, and according to the particular point of the audible spectrum involved. Thus, a typical 12" speaker rated at 15 ohms actually has that 15-ohm impedance at 400 cycles. At 35 cycles the voice coil impedance could be anywhere from 60 to 90 ohms, and at 10,000 cycles from 30 to 50 ohms. See Figure 1.

The steep rise in voice coil impedance in the 40-to-100-cycle region is particularly serious, for it is exactly in this portion of the audible spectrum that we need a good impedance match between voice coil and amplifier in order to reproduce with full richness such instruments as the tympanum, bass viol, cello, organ, and the bottom octave of the piano. And the steep rise in voice coil impedance at the high end decreases treble response.

All typical amplifiers of better quality built today have not taken the above impedance matching problem into account. Thus, although the electrical characteristics of the signal up to the voice coil may have a uniform response, this is promptly affected by the impedance variations of the loudspeaker system. Although the VOLTAGE delivered to the loudspeaker remains constant regardless of frequency, the POWER absorbed by the loudspeaker will *not* be constant because it is a function of both voltage and load resistance.

As an example, let us assume that a 440-cycle tone (Middle A on the piano) is introduced to the loudspeaker. At this frequency the voice coil impedance is actually 16 ohms, as specified by the speaker manufacturer. Let us assume further that the voltage reaching the voice coil is 4 volts. Under these conditions electrical power will be 1 watt. Let us now attempt to reproduce an organ tone 3 octaves lower (55 cps) and of equal intensity. The impedance of the loudspeaker at this frequency would in this case be about 64 ohms (and in many cases loudspeakers have even higher voice coil impedances as one approaches their resonant frequency.) Inasmuch as power, for a constant voltage, varies inversely with the load impedance, the result is that only  $\frac{1}{4}$  of 1 watt of power will actually be absorbed and utilized by the speaker on the aforementioned organ tone.

It therefore follows that the ideal goal is to produce an amplifier containing special circuits that recognize the non-uniform impedance of loudspeakers and provide the means of eliminating this inherent mismatch. We are proud to announce that this long-sought-after goal has now been reached in THE FISHER CUSTOM ELECTRA. These special circuits are what comprise THE FISHER Z-Matic Control.

THE FISHER Z-Matic circuits will not only supply *constant* power to the loudspeaker regardless of its load impedance but, further, will at the mere turn of a control knob provide *additional* compensation to balance the variations of the loudspeaker, its enclosure, or the acoustic characteristics of the room.

### WHAT THE FISHER Z-MATIC CONTROL DOES

The unusual circuitry of THE FISHER Z-Matic Control *automatically* corrects the impedance mismatch condition described earlier. The Z-Matic Control is continuously variable and can be set at any desired point to suit the requirements of the particular program being reproduced, as affected by the existing speaker system, speaker enclosure — in fact, the entire electrical and acoustical system. See Figure 2.

The Z-Matic Control *automatically* makes the corrections for varying load impedance to the exact degree desired by the user to meet his particular acoustic and environmental conditions. The results are truly revolutionary and thrilling to hear, for Z-Matic opens a wide, new door on high fidelity sound reproduction.

IMPORTANT NOTE: THE FISHER Z-Matic Control does what an ordinary Bass Tone Control, or Loudness Balance Control, *cannot* do. The

Z-Matic Control restores to full intensity only those tonal frequencies that suffered attenuation because of speaker system characteristics. For this reason, no "barrel" bass is created. Proof of this desirable achievement is instantly apparent on listening to the male speaking voice, the most usual source of "barrel" bass.

### HOW TO ACHIEVE MAXIMUM ENJOYMENT OF THE FISHER Z-MATIC CONTROL

When the Z-Matic Control is set at minimum, the amplifier will operate in the conventional manner, producing constant voltage regardless of load.

Let us now arbitrarily set the Control with the dot at the top. In this vicinity constant power will be fed to the loudspeaker regardless of variations in speaker impedance. High quality speaker systems with good, overall efficiency will perform best when the Control is in this position. Any rotation past the top position produces increasing multiplication of the electrical factors necessary to overcome the variations of the speaker system and speaker enclosure.

The Z-Matic effect will, of course, be most apparent in the maximum position and, in many cases, represents the closest approach to truly uniform response in terms of *audible power*, which is after all the ultimate criterion.

It should be noted that the three positions described were arbitrary, for the purposes of the discussion. There are an infinite number of intermediate positions available, according to your tastes and needs. May we suggest that you experiment with the Control to familiarize yourself with its tremendous possibilities for increasing the enjoyment of your equipment.

IMPORTANT NOTE: With some speakers, rotating the Z-MATIC Control may result in an over-all volume change. This condition is caused by a slight mismatch between speaker and amplifier. (A nominal 16-ohm voice coil may not be exactly 16 ohms at mid-frequencies.) As long as the change in volume is not severe, the Z-Matic circuit will operate effectively.

### AT YOUR SERVICE

It is the constant desire of Fisher Radio Corporation to have your FISHER equipment give you its best possible performance. Toward that objective, we solicit your correspondence on any special problems that may arise. After you have had an opportunity to familiarize yourself with THE FISHER equipment you purchased, we would appreciate your letting us know how it is meeting your requirements.

SPECIAL NOTE: To maintain your equipment at peak performance, may we suggest that you avail yourself of the facilities and factory trained personnel at our Service Department.

### FISHER RADIO CORPORATION

21-21 Forty-fourth Drive  
Long Island City 1, N. Y.

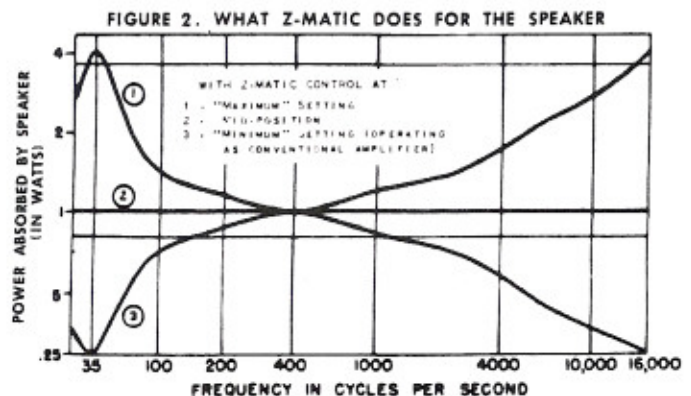
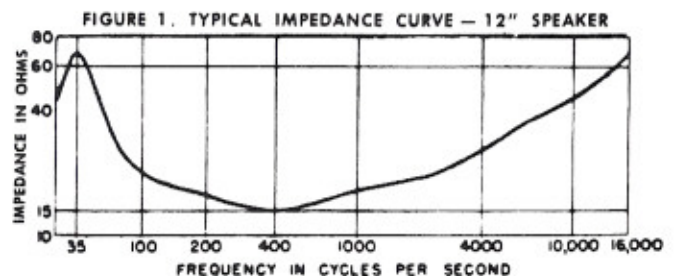

\* PAT. PEND.



# THE FISHER

CUSTOM ELECTRA • SERIES K-14

## ALIGNMENT INSTRUCTIONS

Read this page with extreme care before attempting alignment.

To set pointer, turn tuning capacitor fully closed and set pointer to last reference mark at low frequency end of dial. Set VOLUME CONTROL fully clockwise. Set AFC CONTROL fully counterclockwise,

TONE CONTROLS for "flat" response, Z-MATIC CONTROL to OFF position, and LOUDNESS BALANCE CONTROL to OFF. Use an insulated screwdriver for alignment adjustment.

Steps	DUMMY ANTENNA	COUPLING	FREQUENCY	MODULATION	BAND SWITCH SETTING	DIAL POINTER SETTING	INDICATING METER	ADJUST	REMARKS
1	.01 mfd	Pin 7 (Grid) V-11 (6BE6)	455 KC	400 CPS AM	AM	1000 KC (approx.)	AC Voltmeter to speaker output terminals and 16-ohm load	Z-5, Z-6, Top & Bottom	Adjust for maximum deflection.
2	200 mfd	J-2 (AM Antenna Jack)	1600 KC	"	"	1600 KC	"	C-1L	Disconnect loop. Connect J-2 for external antenna. (See schematic.) Adjust for maximum deflection.
3	"	"	1400 KC	"	"	1400 KC	"	C-1g, C-1j	"
4	"	"	600 KC	"	"	600 KC	"	L-9, L-11, L-12	"
5 Repeat Steps 3 & 4									
6	—	To shield of V-2 (6CB6) Unground shield	10.7 MC	None	FM	Point of no interference	DC VTVM to test point "A"	Z-1, Z-2, Z-3, Top & Bottom of Z-4	Adjust for maximum deflection. (Negative voltage reading.)
7	—	"	"	"	"	"	DC VTVM to test point "B"	Top of Z-4	Adjust for zero between positive & negative readings.
8	Two 120 ohm carbon resistors	To J-1 with resistor in each lead.	106 MC	400 CPS FM (22.5 KC deviation)	FM	106 MC	DC VTVM to test point "A"	C-7	Adjust for maximum deflection. Connect J-1 for 300-ohm antenna. (See schematic.)
9	"	"	90 MC	"	"	90 MC	"	L-4	"
10 Repeat Steps 8 & 9									
11	Two 120 ohm carbon resistors	To J-1 with resistor in each lead.	106 MC	400 CPS FM (22.5 KC deviation)	FM	106 MC	DC VTVM to test point "A"	C-1b, C-1d	"
12	"	"	90 MC	"	"	90 MC	"	L-3, L-6	Expand or compress L-3 and L-6 for maximum deflection.
13 Repeat Steps 11 & 12									



TOP VIEW OF CHASSIS SHOWING LOCATION OF MAJOR COMPONENTS AND ADJUSTMENTS

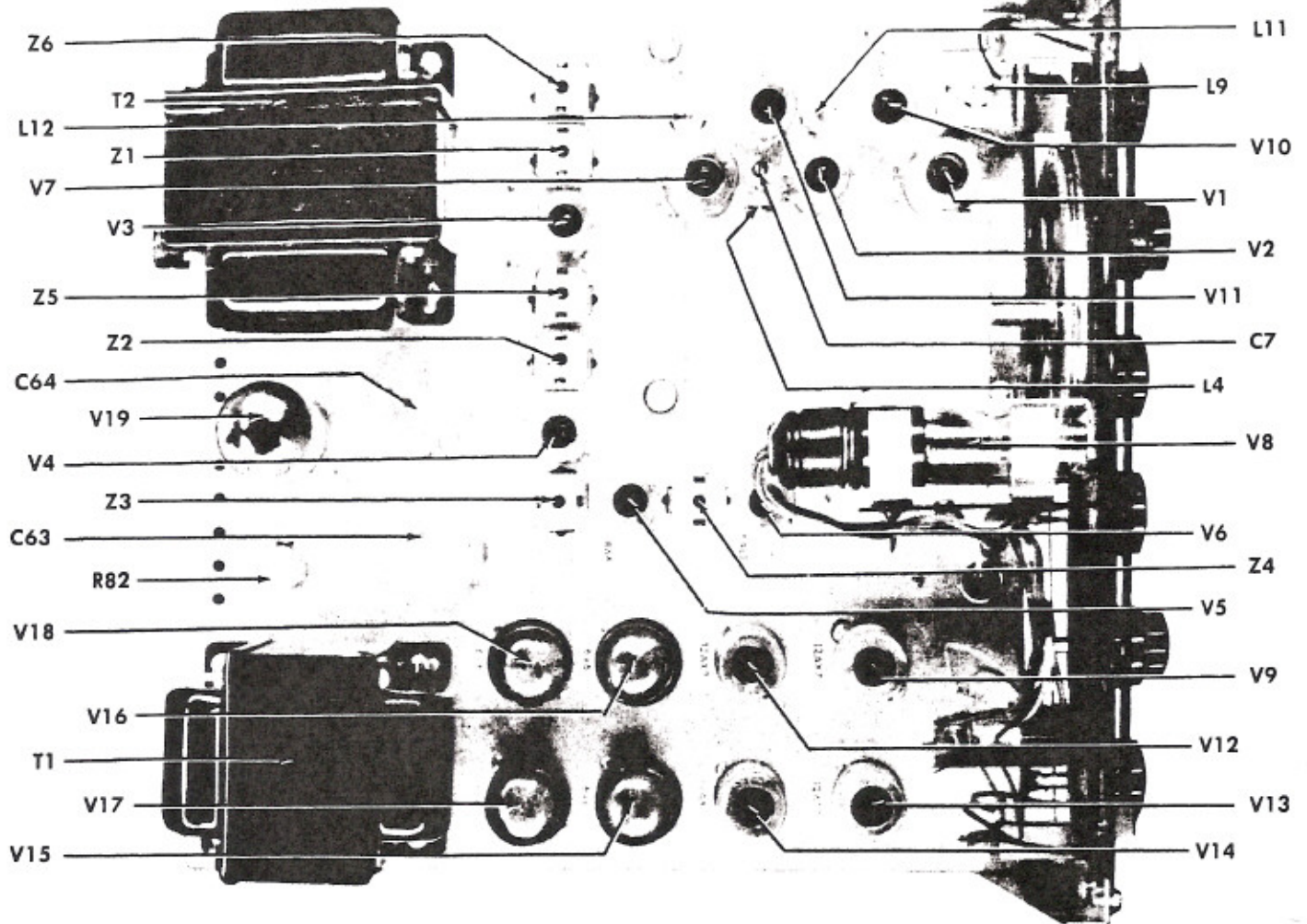

BOTTOM VIEW OF CHASSIS SHOWING LOCATION OF MAJOR COMPONENTS AND ADJUSTMENTS

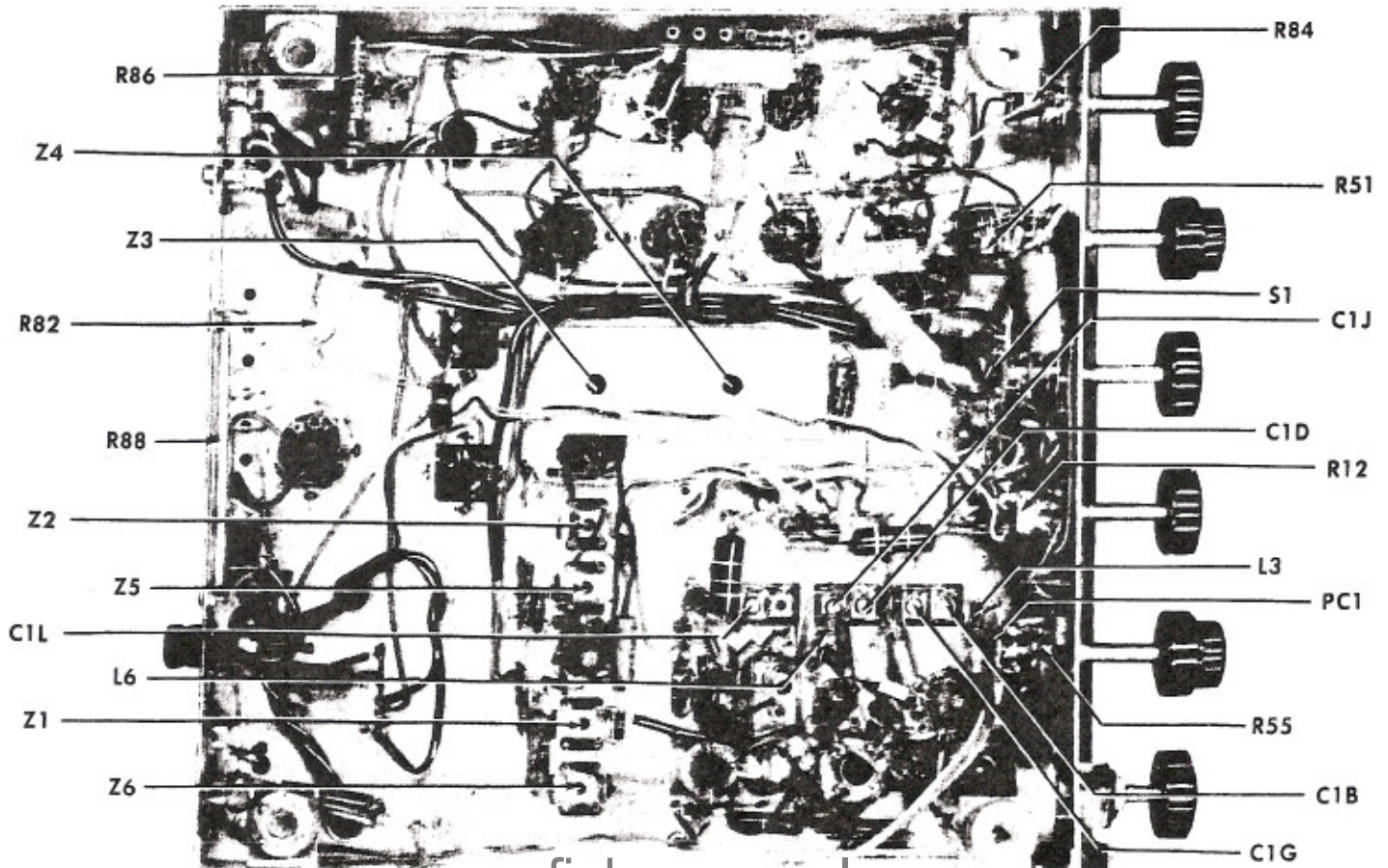



## VOLTAGE REFERENCE CHART

### SOCKET PINS

TUBE	1	2	3	4	5	6	7	8	9	
V-1	6BQ7A	125	-.95	0	0	6.3AC	240	90	125	0
V-2	6CB6	-3.2	0	0	6.3AC	95	95	0	--	--
V-3	6BA6	-1	0	0	6.3AC	90	95	.7	--	--
V-4	6BA6	-.1	0	0	6.3AC	90	92	1.9	--	--
V-5	6BA6	0	0	0	6.3AC	88	90	1.2	--	--
V-6	6AL5	2.4	-2.15	0	6.3AC	.2	0	.3	--	--
V-7	6BQ7A	96	-2.8	0	6.3AC	96	0	3	0	
V-8	6E5	6.3AC	40	-1.9	210	0	0	--	--	--
V-9	12AX7	110	-.5	0	0	9.4	115	0	.7	NC
V-10	6BA6	-1.5	0	0	6.3AC	100	103	.8	--	--
V-11	6BE6	-11.5	0	6.3AC	0	104	104	-1.1	--	--
V-12	12AX7	210	7	26	9.4	18.5	170	0	1.2	NC
V-13	12AT7	66	0	1	18.5	28	145	66	68	NC
V-14	12AX7	230	0	2	6.3AC	6.3AC	210	0	2	0
V-15	6V6	0	0	340	310	8.5	310	6.3AC	29	--
V-16	6V6	0	0	340	310	8.5	310	6.3AC	29	--
V-17	6V6	0	0	340	310	8.5	310	6.3AC	29	--
V-18	6V6	0	6.3AC	340	310	8.5	310	0	29	--
V-19	5U4	NC	380	NC	360AC	NC	360AC	NC	380	--

NOTES: Line voltage set at 117V, 60 cycles. Voltage readings may vary  $\pm 10\%$  under normal operating conditions. All voltages read with vacuum tube voltmeter under no-signal conditions. Band switch set at FM except for V-10 and V-11. For these measurements set the band switch to AM. Volume control at maximum CW, loudness balance off, Z-Matic off, tone controls set for flat response. AFC minimum. All voltages read with respect to chassis. Readings are in positive volts, DC, unless otherwise specified.

## RESISTANCE REFERENCE CHART

### SOCKET PINS

TUBE	1	2	3	4	5	6	7	8	9	
V-1	6BQ7A	INF.	400K	0	.3	.35	30M	INF.	INF.	0
V-2	6CB6	1.5M	0	0	.2	40M	40M	0	--	--
V-3	6BA6	500K	0	0	.1	30M	30M	100	--	--
V-4	6BA6	260K	0	0	.1	30M	30M	220	--	--
V-5	6BA6	.9	0	0	.1	15M	15M	100	--	--
V-6	6AL5	8K	8K	0	.1	2M	0	2M	--	--
V-7	6BQ7A	30M	4.7K	0	0	.1	30M	1M	1K	0
V-8	6E5	.1	70M	7K	50M	0	0	--	--	--
V-9	12AX7	30M	18M	0	0	30	30M	3.2M	1.5K	NC
V-10	6BA6	3.3M	0	0	.2	20M	20M	68	--	--
V-11	6BE6	22K	.6	.1	0	20M	20M	3.3M	--	--
V-12	12AX7	20M	2.3M	50K	30	40	30M	80K	2.7K	NC
V-13	12AT7	15M	350K	1.5K	40	50	20M	15M	100K	NC
V-14	12AX7	20M	470K	1K	.1	.1	20M	470K	1K	0
V-15	6V6	0	0	30M	30M	470K	30M	.1	50	--
V-16	6V6	0	0	30M	30M	470K	30M	.1	50	--
V-17	6V6	0	0	30M	30M	470K	30M	.1	50	--
V-18	6V6	0	.1	30M	30M	470K	30M	0	50	--
V-19	5U4	NC	500M	NC	24	NC	24	NC	500M	--

CAUTION: Be certain to disconnect AC Line Cord when making these measurements.

NOTES: Band switch set at FM except for V-10 and V-11. For these measurements set band switch to AM. Volume control at maximum clockwise. AFC control at minimum. Z-Matic off. Tone control for flat response. Loudness off. All resistance in ohms unless otherwise specified. M equals megohms. K equals kilohms. Measurements taken with respect to chassis.

### FM ANTENNA CONNECTIONS



### AM ANTENNA CONNECTIONS

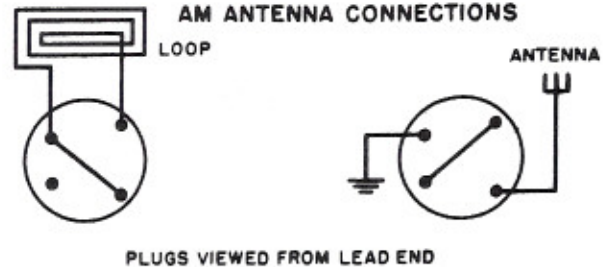

## DIAL STRINGING INSTRUCTIONS

### DIAL CORD REPLACEMENT INSTRUCTIONS

1. Remove chassis from cabinet.
2. Remove defective cord and dial pointer.
3. Remove dial panel by unscrewing four hexagonal self-tapping screws.
4. Restring new cord as shown in illustration.
5. Remount dial panel.
6. Mount dial pointer, and with variable capacitor fully in counterclockwise position, center pointer over index mark at low-frequency end of dial.
7. Secure dial pointer in place by applying household cement.

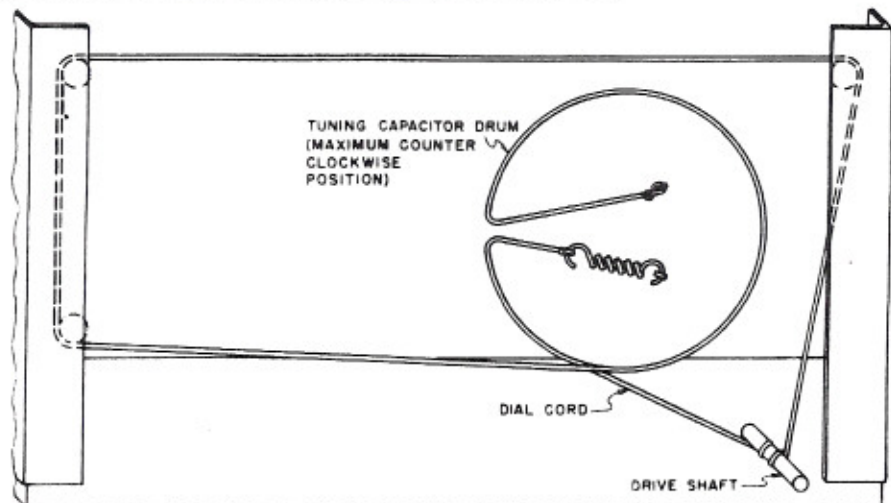



Symbol	DESCRIPTION	Part No.	Symbol	DESCRIPTION	Part No.
C-1	Capacitor, FM-AM Variable	C-509-118	R-6	Resistor, Composition: 1000 ohms, 10%; 1/2 W	RC20BF102K
C-2	Capacitor, Ceramic: 33 mmfd; 500 V	C-3337	R-7	Resistor, Composition: 1 megohm, 10%; 1/2 W	RC20BF105K
C-3	Capacitor, Ceramic: 10 mmfd; 500 V	C-1317	R-8	Resistor, Composition: 100 ohms, 10%; 1/2 W	RC20BF101K
C-4	Capacitor, Ceramic: 220 mmfd; 500 V	C-3306	R-9	Resistor, Composition: 1 megohm, 10%; 1/2 W	RC20BF105K
C-5	Capacitor, Ceramic: 500 mmfd; 500 V	C-1315	R-10	Resistor, Composition: 68,000 ohms, 10%; 1/2 W	RC20BF683K
C-6	Capacitor, Ceramic: 5000 mmfd; 500 V	C-3338	R-11	Resistor, Composition: 1000 ohms, 10%; 1/2 W	RC20BF102K
C-7	Capacitor, Trimmer: 1-6 mmfd; NPO	C-520-159	R-12	Potentiometer, Composition: 2 megohms	R-50000-8
C-8	Capacitor, Ceramic: 47 mmfd; 500 V	C-3350	R-13	Resistor, Composition: 100 ohms, 10%; 1/2 W	RC20BF101K
C-9	Capacitor, Ceramic: 33 mmfd; 500 V	C-3337	R-14	Resistor, Composition: 1000 ohms, 10%; 1/2 W	RC20BF102K
C-10	Capacitor, Ceramic: 5000 mmfd; 500 V	C-2146	R-15, R-16	Resistor, Composition: 68,000 ohms, 10%; 1/2 W	RC20BF683K
C-11	Capacitor, Ceramic: 5000 mmfd; 500 V	C-3338	R-17	Resistor, Composition: 47,000 ohms, 10%; 1/2 W	RC20BF473K
C-12	Capacitor, Ceramic: 2.2 mmfd, 10%; 500 V	C-3039	R-18	Resistor, Composition: 220 ohms, 10%; 1/2 W	RC20BF221K
C-13	Capacitor, Ceramic: 500 mmfd; 500 V	C-1315	R-19	Resistor, Composition: 1000 ohms, 10%; 1/2 W	RC20BF102K
C-14	Capacitor, Molded Tubular: .047 mfd; 400 V	C-2944	R-20	Resistor, Composition: 220,000 ohms, 10%; 1/2 W	RC20BF224K
C-15, C-16, C-18	Capacitor, Ceramic: 5000 mmfd; 500 V	C-2146	R-21	Resistor, Composition: 2.2 megohms, 10%; 1/2 W	RC20BF225K
C-19	Capacitor, Ceramic: 100 mmfd; 500 V	C-3339	R-22	Resistor, Composition: 100 ohms, 10%; 1/2 W	RC20BF101K
C-20	Capacitor, Ceramic: 5000 mmfd; 500 V	C-2146	R-23	Resistor, Composition: 1000 ohms, 10%; 1/2 W	RC20BF102K
C-21	Capacitor, Ceramic: 100 mmfd; 500 V	C-3339	R-24	Resistor, Composition: 68 ohms, 10%; 1/2 W	RC20BF680K
C-22	Capacitor, Ceramic: 5000 mmfd; 500 V	C-2146	R-25	Resistor, Composition: 1 megohm, 10%; 1/2 W	RC20BF105K
C-23, C-24, C-25	Capacitor, Ceramic: 300 mmfd, 10%; 500 V	C-3424	R-26	Resistor, Composition: 2.2 megohms, 10%; 1/2 W	RC20BF225K
C-26	Capacitor, Ceramic: 1000 mmfd, 10%; 500 V	C-3419	R-27	Resistor, Composition: 68,000 ohms, 10%; 1/2 W	RC20BF683K
C-27	Capacitor, .022 mfd; 400 V	C68P223M4	R-28	Resistor, Composition: 1500 ohms, 10%; 1/2 W	RC20BF152K
C-28	Capacitor, Electrolytic: 8 mfd; 50 V	C-531-118	R-29	Resistor, Composition: 1000 ohms, 10%; 1/2 W	RC20BF102K
C-29	Capacitor, .022 mfd; 400 V	C68P223M4	R-30, R-31	Resistor, Composition: 6800 ohms, 10%; 1/2 W	RC20BF682K
C-30	Capacitor, .01 mfd; 400 V	C68P103M4	R-32	Resistor, Composition: 47,000 ohms, 10%; 1/2 W	RC20BF473K
C-31	Capacitor, .0082 mfd, 10%; 400 V	C68P822K4	R-33	Resistor, Composition: 18 megohms, 10%; 1/2 W	RC20BF186K
C-32	Capacitor, Ceramic: 15 mmfd, 10%; 500 V	C-1316	R-34	Resistor, Composition: 100,000 ohms, 10%; 1/2 W	RC20BF104K
C-33	Capacitor, Ceramic: 2.2 mmfd, 10%; 500 V	C-3039	R-35, R-36	Resistor, Composition: 2.2 megohms, 10%; 1/2 W	RC20BF225K
C-34	Capacitor, Ceramic: 220 mmfd; 500 V	C-3306	R-37	Resistor, Composition: 1 megohm, 10%; 1/2 W	RC20BF105K
C-35	Capacitor, Molded Tubular: .01 mfd; 400 V	C-3155	R-38	Resistor, Composition: 39,000 ohms, 10%; 1/2 W	RC20BF393K
C-36	Capacitor, Ceramic: 4.7 mmfd; 500 V	C-1779	R-39	Resistor, Composition: 47,000 ohms, 10%; 1/2 W	RC20BF473K
C-37	Capacitor, Ceramic: 220 mmfd; 500 V	C-3306	R-40	Resistor, Composition: 100,000 ohms, 10%; 1/2 W	RC20BF104K
C-38	Capacitor, Molded Tubular: .047 mfd; 400 V	C-2944	R-41	Resistor, Composition: 1500 ohms, 10%; 1/2 W	RC20BF152K
C-39	Capacitor, Ceramic: 10 mmfd, N750; 500 V	C-2851	R-42	Resistor, Composition: 1 megohm, 10%; 1/2 W	RC20BF105K
C-40	Capacitor, Ceramic: 220 mmfd; 500 V	C-3306	R-43	Resistor, Composition: 68 ohms, 10%; 1/2 W	RC20BF680K
C-41	Capacitor, Molded Tubular: .01 mfd; 400 V	C-3155	R-44	Resistor, Composition: 1000 ohms, 10%; 1/2 W	RC20BF102K
C-42	Capacitor, .01 mfd; 400 V	C68P103M4	R-45	Resistor, Composition: 1 megohm, 10%; 1/2 W	RC20BF105K
C-43	Capacitor, .1 mfd; 400 V	C68P104M4	R-46	Resistor, Composition: 22,000 ohms, 10%; 1/2 W	RC20BF223K
C-44	Capacitor, Ceramic: 560 mmfd, 10%; 500 V	C-3336	R-47	Resistor, Composition: 470,000 ohms, 10%; 1/2 W	RC20BF474K
C-45	Capacitor, Ceramic: 420 mmfd, 10%; 500 V	C-3308	R-48	Resistor, Composition: 1000 ohms, 10%; 1/2 W	RC20BF102K
C-46, C-47	Capacitor, .01 mfd, 10%; 200 V	C68P103K2	R-49	Resistor, Composition: 47,000 ohms, 10%; 1/2 W	RC20BF473K
C-48	Capacitor, .01 mfd; 400 V	C68P103M4	R-51-A, B	Potentiometer, Composition: Dual 500,000 ohms	R-531-114
C-49	Capacitor, .22 mfd; 200 V	C68P224V2	R-52	Resistor, Composition: 2.2 megohms, 10%; 1/2 W	RC20BF225K
C-50	Capacitor, Ceramic: 220 mmfd, 10%; 500 V	C-3407	R-53	Resistor, Composition: 2200 ohms, 10%; 1/2 W	RC20BF222K
C-51	Capacitor, Electrolytic: 25 mfd; 25 V	C-3350	R-54	Resistor, Composition: 47,000 ohms, 10%; 1/2 W	RC20BF473K
C-52	Capacitor, .1 mfd; 400 V	C68P104M4	R-55-A, B	Potentiometer, Composition: Dual 1 megohm, 500,000 ohms	R-531-115
C-53, C-54	Capacitor, .022 mfd; 400 V	C68P223M4	R-56	Resistor, Composition: 2700 ohms, 10%; 1/2 W	RC20BF272K
C-55	Capacitor, .1 mfd; 400 V	C68P104M4	R-57	Resistor, Composition: 100,000 ohms, 10%; 1/2 W	RC20BF104K
C-56, C-57	Capacitor, Electrolytic: 4 mfd; 450 V	C-531-129	R-58, R-59	Resistor, Composition: 220,000 ohms, 10%; 1/2 W	RC20BF224K
C-58	Capacitor, .1 mfd; 400 V	C68P104M4	R-60	Resistor, Composition: 1500 ohms, 10%; 1/2 W	RC20BF152K
C-59	Capacitor, .001 mfd, 10%; 1000 V	C68P102K10	R-61, R-62	Resistor, Composition: 100,000 ohms, 10%; 1/2 W	RC20BF104K
C-60	Capacitor, Electrolytic: 50 mfd; 50 V	C-508-115	R-63, R-64	Resistor, Composition: 470,000 ohms, 10%; 1/2 W	RC20BF474K
C-61	Capacitor, Ceramic: 100 mmfd; 500 V	C-3339	R-65	Resistor, Composition: 1000 ohms, 10%; 1/2 W	RC20BF102K
C-62	Capacitor, Molded Tubular: .01 mfd; 600 V	C-2747	R-66	Resistor, Composition: 100,000 ohms, 10%; 1/2 W	RC20BF104K
C-63-A, B, C	Capacitor, Electrolytic: 40x40x20; 450 V	C-50028-1	R-67, R-68	Resistor, Composition: 4700 ohms, 10%; 1/2 W	RC20BF472K
C-64-A, B, C	Capacitor, Electrolytic: 40x40x20; 450 V	C-50028-1	R-69	Resistor, Composition: 100,000 ohms, 10%; 1/2 W	RC20BF104K
C-65, C-66, C-67	Capacitor, Ceramic: 5000 mmfd; 500 V	C-2146	R-70	Resistor, Composition: 1000 ohms, 10%; 1/2 W	RC20BF102K
C-68, C-69	Capacitor, .01 mfd; 400 V	C68P103M4	R-71	Resistor, Composition: 68 ohms, 10%; 1/2 W	RC20BF680K
C-70	Fuse: 3.2 Amp. "Slo-Blo"	F-3319	R-72, R-73	Resistor, Composition: 470,000 ohms, 10%; 1/2 W	RC20BF474K
F-1	Lamp #47	L-2148	R-74	Resistor, Composition: 68 ohms, 10%; 1/2 W	RC20BF680K
I-1, I-2, I-3	Jack: Antenna	J-520-137	R-75	Resistor, Composition: 10 ohms, 10%; 1/2 W	RC20BF100K
I-4, I-5, I-6	Jack: 1 Female Contact	J-3143	R-76	Resistor, Composition: 68 ohms, 10%; 1/2 W	RC20BF680K
J-1, J-2	Jack: 1 Female Contact	J-1030	R-77, R-78	Resistor, Composition: 2700 ohms, 10%; 1/2 W	RC20BF272K
J-3	Jack: 1 Female Contact	J-3143	R-79	Resistor, Composition: 68 ohms, 10%; 1/2 W	RC20BF680K
J-4	Jack: 1 Female Contact	J-531-130	R-80	Resistor, Composition: 10 ohms, 10%; 1/2 W	RC20BF100K
J-5, J-6	Jack: Speaker	J-1152	R-81	Resistor, Composition: 2200 ohms, 10%; 1/2 W	RC20BF222K
J-7	Jack: AC Receptacle	L-509-139	R-82	Resistor, Wirewound: 5500 ohms	R-531-133
J-8, J-9	Coil: Elevator Transformer	L-509-139	R-83	Resistor, Composition: 270 ohms, 10%; 1/2 W	RC20BF271K
L-1, L-2	Coil: FM Antenna	L-509-159	R-84	Potentiometer, Composition: 1000 ohms	R-531-113
L-3	Coil: FM Oscillator	L-509-160	R-85	Resistor, Composition: 22,000 ohms, 10%; 1/2 W	RC20BF223K
L-4	Choke, RF: 2.2 microhenrys	L-3352	R-86	Resistor, Wirewound: 2 ohms tapped at 1 ohm, 10 W	R-522-118
L-5	Choke, RF	L-509-162	R-87	Resistor, Composition: 2200 ohms, 10%; 1/2 W	RC20BF222K
L-6	Choke, RF	L-509-147	R-88-A, B, C	Resistor, Wirewound: 150 ohms tapped at 50 ohms; 6000 ohms	R-531-134
L-7	Choke, RF: 2.2 microhenrys	L-3352	R-89	Resistor, Composition: 1000 ohms, 10%; 2 W	RC40BF102K
L-8	Coil: AM Antenna	L-509-137	R-90	Resistor, Composition: 22,000 ohms, 10%; 1 W	RC30BF223K
L-9	Coil: AM Antenna Loading	L-509-153	R-91	Resistor, Composition: 47,000 ohms, 10%; 1/2 W	RC20BF473K
L-10	Coil: AM RF	L-509-136	R-92	Resistor, Composition: 22 ohms, 10%; 1/2 W	RC20BF220K
L-11	Coil: AM RF	L-509-134	R-93	Resistor, Composition: 150,000 ohms, 10%; 1/2 W	RC20BF154K
L-12	Coil: AM Oscillator	L-520-156	S-1	Switch, Selector	S-531-132
L-13, L-14	Choke, RF	L-509-156	S-2	Switch, Loudness Balance, Part of R-51	
L-15	Choke, RF	L-509-140	S-3	Switch, Power, Part of R-12	
L-16	Choke, RF: Bi-Filar Winding	AS-520-163	S-4	Switch, Z-Matic, Part of R-84	
L-17	Dipole: FM	L-509-133	T-1	Transformer, Output	T-531-117
L-18	Loop: AM	L-509-133	T-2	Transformer, Power	T-531-116
PC-1	Printed Circuit	PC-531-128	Z-1, Z-2, Z-3	Transformer, FM IF	ZZ2987
R-1, R-2	Resistor, Composition: 470,000 ohms, 10%; 1/2 W	RC20BF474K	Z-4	Transformer: FM Disc	ZZ2986
R-3	Resistor, Composition: 4700 ohms, 10%; 2 W	RC40BF472K	Z-5	Transformer: AM IF	ZZ2984
R-4	Resistor, Composition: 470,000 ohms, 10%; 1/2 W	RC20BF474K	Z-6	Transformer: AM IF	ZZ2985
R-5	Resistor, Composition: 4700 ohms, 10%; 1/2 W	RC20BF472K			



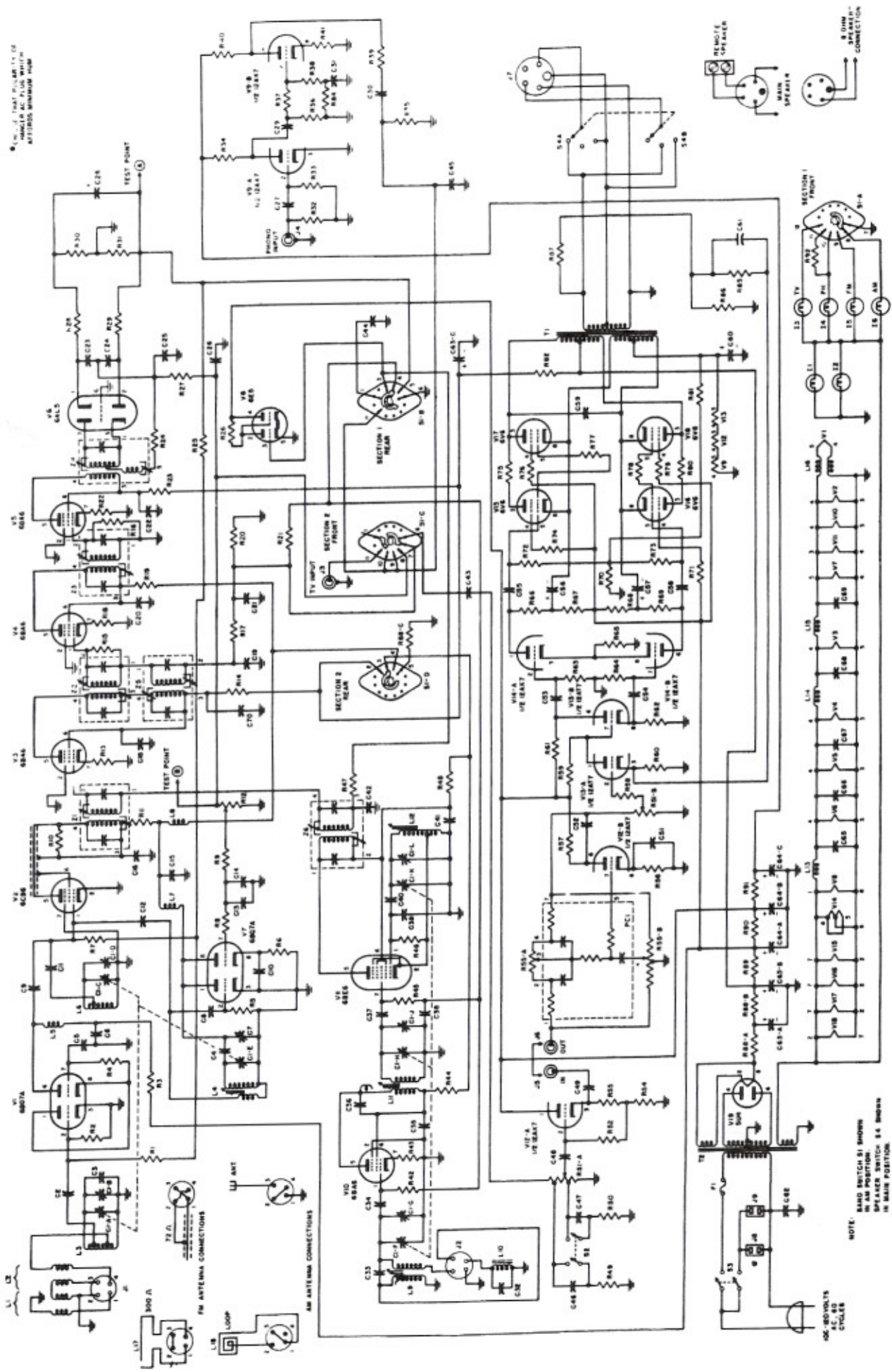

NOTE: THAT PLUGS AT REAR OF AC PLUG WHICH ATTACHES TO MAIN POWER

NOTE: BAND SWITCH S1 SHOWN IN AM POSITION. SPEAKER SWITCH S4 SHOWN IN MAIN POSITION.

100-80 VOLTS A.C. 60 CYCLES

K-15 SHEARSON



**FISHER RADIO CORPORATION · NEW YORK**

NLN1681-103

[www.fisherconsoles.com](http://www.fisherconsoles.com)

25P49