





ISO 9001 CERTIFIED

607 NW 27th Ave  
Ocala, FL 34475  
Phone: (352) 629-5020 or 800-533-3569  
Fax: (352)-629-2902

## OPERATION MANUAL

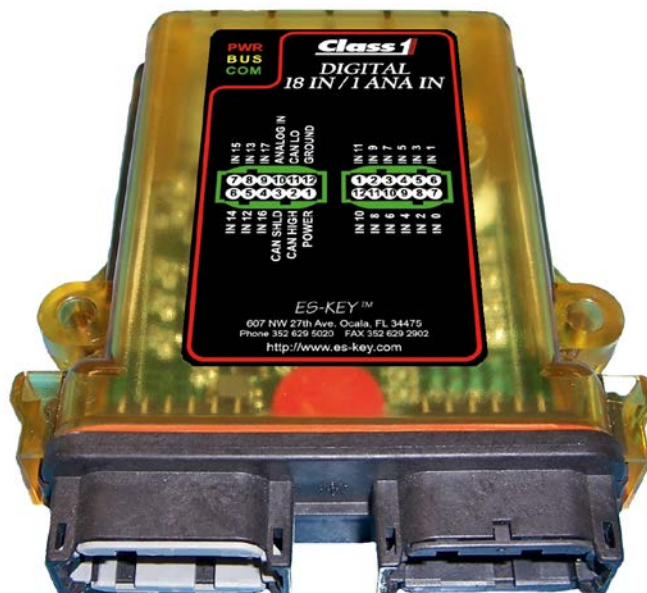
**ES-Key**  
**18 Input module (selectable polarity)**  
**with 3 outputs (selectable polarity)**  
**with 1 analog (selectable 0-5V or 4-20mA)**  
P/N 610-00030



  607 NW 27th Ave Ocala, FL 34475 Phone : (352) 629-5020 Fax : (352)-629-2902	FOR EXTERNAL DISTRIBUTION			PAGE	1 of 13
	<b>OPERATION MANUAL</b>			DATE	9/05/2014
PRODUCT GROUP	ES-Key	P/N	FSG-MNL-00108	REV	1.00
PRODUCT	18 input module with 3 outputs			BY	GMC

<b>1.</b>	<b>REVISION LOG .....</b>	<b>1</b>
<b>2.</b>	<b>MODULE OVERVIEW .....</b>	<b>2</b>
2.1.	SCOPE .....	2
2.2.	PART NUMBERS.....	2
2.3.	SETUP.....	2
<b>3.</b>	<b>MODULE OPERATION .....</b>	<b>3</b>
3.1.	SELECTABLE POLARITY INPUTS .....	3
3.1.1.	<i>Input polarity selection.....</i>	3
3.2.	ANALOG INPUT .....	4
3.2.1.	<i>Analog selection .....</i>	4
3.3.	SELECTABLE POLARITY OUTPUTS .....	5
3.3.1.	<i>Output polarity selection.....</i>	5
3.4.	MODULE TYPE AND ADDRESS.....	6
3.4.1.	<i>Device type selection.....</i>	6
3.4.2.	<i>Special address 9 (vocation module feature).....</i>	7
3.5.	INPUT/OUTPUT MEMORY SPACE.....	8
<b>4.</b>	<b>CONNECTOR DESCRIPTION.....</b>	<b>9</b>
4.1.	CONNECTOR A (GRAY) .....	9
4.2.	CONNECTOR B (BLACK) .....	9
4.2.1.	<i>Terminating resistor requirement (CAN communication).....</i>	10
4.3.	SYSTEM COMPATIBILITY .....	10
<b>5.</b>	<b>MOUNTING .....</b>	<b>11</b>
<b>6.</b>	<b>DIAGNOSTICS .....</b>	<b>12</b>
<b>7.</b>	<b>GLOSSARY .....</b>	<b>13</b>
<b>8.</b>	<b>TECHNICAL DETAILS .....</b>	<b>13</b>
8.1.	WEEE (WASTE OF ELECTRICAL AND ELECTRONIC EQUIPMENT) DIRECTIVE.....	13

## 1. Revision Log

Rev	Date	Approved	Changes
1.00	9-05-2014	GMC	Initial requirements

 607 NW 27th Ave Ocala, FL 34475 Phone : (352) 629-5020 Fax : (352)-629-2902	FOR EXTERNAL DISTRIBUTION				PAGE	2 of 13
	<b>OPERATION MANUAL</b>				DATE	9/05/2014
	PRODUCT GROUP	ES-Key	P/N	FSG-MNL-00108	REV	1.00
	PRODUCT	18 input module with 3 outputs			BY	GMC

## 2. Module Overview

### 2.1. Scope

The ES-Key™ 18 digital, 3 output, with 1 analog input module is a Class 1 ES-Key network module designed for use in a ES-Key™ electrical system network. This module has eighteen (18) configurable polarity inputs (positive or ground), three configurable outputs (positive or ground), and one (1) analog input (0-5 volt or 4-20mA). The inputs are reported to the ES-Key network via J1939 CAN messages and can be tied to desired functionality through the ES-Key database by using the ES-Key professional software.

### 2.2. Part numbers

Dual Analog to CAN with Accelerometer                      Hale – p/n    610-00030

### 2.3. Setup

When the module leaves the factory it is configured with the following default configurations.

Function	Mode	Position	Function	Mode	Position	Function	Mode	Position
IN 0	POS	DOWN	IN 8	POS	DOWN	IN 16	POS	DOWN
IN 1	POS	DOWN	IN 9	POS	DOWN	IN 17	POS	DOWN
IN 2	POS	DOWN	IN 10	POS	DOWN	OUT 0	POS	DOWN
IN 3	POS	DOWN	IN 11	POS	DOWN	OUT 1	POS	DOWN
IN 4	POS	DOWN	IN 12	POS	DOWN	OUT 2	POS	DOWN
IN 5	POS	DOWN	IN 13	POS	DOWN	ANALOG	0-5 VOLT	DOWN
IN 6	POS	DOWN	IN 14	POS	DOWN	DEVICE	TYPE 4	DOWN
IN 7	POS	DOWN	IN 15	POS	DOWN	AUX	STANDARD	DOWN

(Note: the AUX switch needs to be in the down position for standard operation)

H2	H3	H4	H5	H6	H7
Pos 2	Pos 2	Pos 2	Pos 1	Pos 1	Pos 1

(Note: Selection switches are only read on power up).

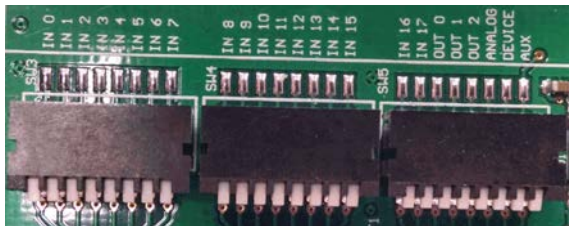

Figure 1. Input polarity selection switches.

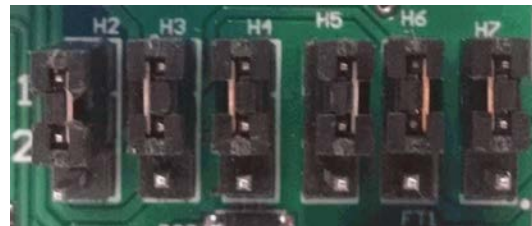



Figure 2. Input/output selection jumpers.

  607 NW 27th Ave Ocala, FL 34475 Phone : (352) 629-5020 Fax : (352)-629-2902	FOR EXTERNAL DISTRIBUTION			PAGE	3 of 13
	<b>OPERATION MANUAL</b>			DATE	9/05/2014
PRODUCT GROUP	ES-Key	P/N	FSG-MNL-00108	REV	1.00
PRODUCT	18 input module with 3 outputs			BY	GMC

### 3. Module Operation

#### 3.1. Selectable polarity inputs

The module can be configured to use 18 digital inputs that can be configured for either positive or ground input polarity (see section 3.1.1). Inputs 0-15 are always available to the user. Inputs 16 and 17 are shared with outputs 0 and 1 and the user must select which ones to use (see section 3.1.1). The input is flagged as ACTIVE in the ES-Key database when the voltage level of the input is within the required range (refer to the table below).

Input Polarity	Input requirement
Positive	Input is flagged as ACTIVE when its voltage is greater than 60% of supply power.
Ground	Input is flagged as ACTIVE when its voltage is less than 40% of supply power.

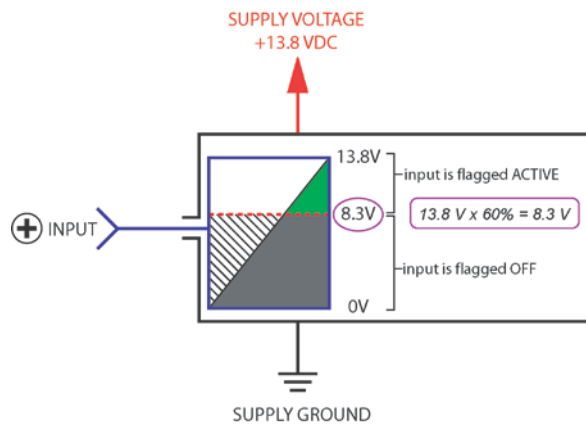

Figure 3. Positive input example.

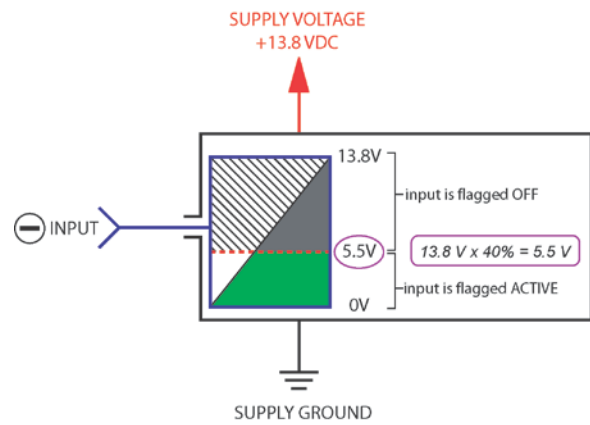

Figure 4. Ground input example.



The examples above illustrate the voltage range required for an input to be flagged as ACTIVE to the ES-Key database. The voltage range is based on the polarity of the input (positive or ground) and the voltage level of the supply voltage. In figure 1 the input is a positive polarity type, the supply voltage is 13.8 VDC, and the valid voltage range for the input is 8.3 VDC and greater (less than 8.3 VDC flags the input as OFF).

##### 3.1.1. Input polarity selection

The polarity of each input is selected by setting the input polarity selection switches and the input/output selection jumpers (located inside of the case) to the desired positions. The switches are labeled IN 0 through IN 17 and are directly related to the physical inputs. Each input can be placed in the POS (positive) or NEG (ground) position. When the switch is down it is in the positive position. When the switch is up it is in the negative position. Set the selection jumpers as needed for inputs greater than 15.

Input	H2	H3	H4	H5	H6	H7
16	Pos 1	N/A	N/A	Pos 1	N/A	N/A
17	N/A	Pos 1	N/A	N/A	Pos 1	N/A

(Note: Selection switches are only read at power up).

  607 NW 27th Ave Ocala, FL 34475 Phone : (352) 629-5020 Fax : (352)-629-2902	FOR EXTERNAL DISTRIBUTION			PAGE	4 of 13
	<b>OPERATION MANUAL</b>			DATE	9/05/2014
PRODUCT GROUP	ES-Key	P/N	FSG-MNL-00108	REV	1.00
PRODUCT	18 input module with 3 outputs			BY	GMC

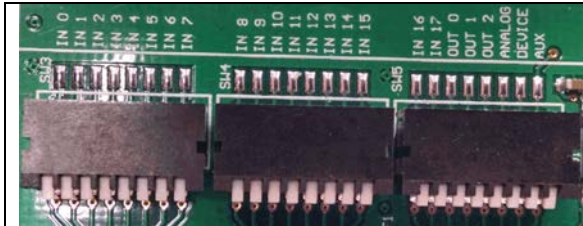

Figure 5 Input polarity selection switches.

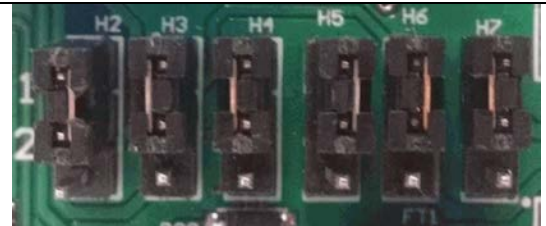

Figure 6. Input/output selection jumpers.

### 3.2. Analog Input

The module has 1 analog input that can be configured for either a 0-5 volt input or a 4-20mA input (see section 3.2.1). The module can also be configured to supply a positive (5 volt or 9 volt) reference and a ground reference. If the references are configured the module will no longer be able to use input 16 and 17 or output 0 and 1.

#### 3.2.1. Analog selection

The mode of the analog input is selected by setting the selection switch and the input/output selection jumpers (located inside of the case) to the desired positions. The selection switch is labeled ANALOG and is directly related to the analog input mode. The analog input can be placed in a 0-5 volt mode or a 4-20mA mode. When the switch is down it is in the 0-5 volt mode. When the switch is up it is in the 4-20mA mode. Set the selection jumpers as needed.

Function	H2	H3	H4	H5	H6	H7
Analog Input	Pos 1	Pos 1	Pos 1	N/A	N/A	N/A
Neg REF	N/A	N/A	N/A	Pos 2	N/A	N/A
Pos REF	N/A	N/A	N/A	N/A	Pos 2	N/A
5 V REF	N/A	N/A	N/A	N/A	N/A	Pos 1
9 V REF	N/A	N/A	N/A	N/A	N/A	Pos 2

(Note: Selection switches are only read at power up).



Figure 7. Selection switches.

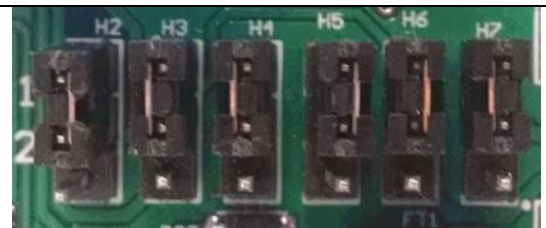



Figure 8. Input/output selection jumpers.

  607 NW 27th Ave Ocala, FL 34475 Phone : (352) 629-5020 Fax : (352)-629-2902	FOR EXTERNAL DISTRIBUTION			PAGE	5 of 13	
	<b>OPERATION MANUAL</b>			DATE	9/05/2014	
	PRODUCT GROUP	ES-Key	P/N	FSG-MNL-00108	REV	1.00
	PRODUCT	<b>18 input module with 3 outputs</b>			BY	GMC

### 3.3. Selectable polarity outputs

The module has 3 digital outputs that can be configured for either positive or ground output polarity (see section 3.3.1). If the outputs are configured for use then the module cannot use input 16 and 17 or the analog input. These outputs are activated through associations within the ES-Key database and are designed to drive inductive, capacitive, or resistive loads (relays, solenoids, indicators, etc). These outputs are overload and short circuit protected. The maximum load tied to each output should be limited to 0.25 Amps (loads more than this may cause the output to shutdown due to thermal overload). The outputs will report an over current condition to the Es-key network and if any of the outputs are in an over current situation the COM LED on the module will be flashing at a fast rate to give the user an indication that one of the outputs is in over current condition. When an output goes into an over current situation the affected output will shut down and attempt to turn back on three times. If on the third try the over current situation is still present the output will shut down until the output is physically shut off to reset it.

#### 3.3.1. Output polarity selection

The polarity of each output is selected by setting the output polarity selection switches and the input/output selection jumpers (located inside of the case) to the desired positions. The switches are labeled OUT 0 through OUT 2 and are directly related to the physical outputs. Each output can be placed in the POS (positive) or NEG (ground) position. When the switch is down it is in the positive position. When the switch is up it is in the negative position. Set the selection jumpers as needed for outputs 0 through 2.

Output	H2	H3	H4	H5	H6	H7
0	Pos 2	N/A	N/A	Pos 1	N/A	N/A
1	N/A	Pos 2	N/A	N/A	Pos 1	N/A
2	N/A	N/A	Pos 2	N/A	N/A	N/A

(Note: Selection switches are only read at power up).

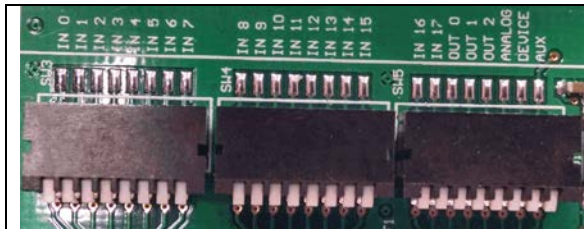



Figure 9 Output polarity selection switches.



Figure 10. Input/output selection jumpers.



  607 NW 27th Ave Ocala, FL 34475 Phone : (352) 629-5020 Fax : (352)-629-2902	FOR EXTERNAL DISTRIBUTION			PAGE	6 of 13	
	<b>OPERATION MANUAL</b>			DATE	9/05/2014	
	PRODUCT GROUP	ES-Key	P/N	FSG-MNL-00108	REV	1.00
	PRODUCT	18 input module with 3 outputs			BY	GMC

### 3.4. Module type and address

The 18 Input Module is recognized by the ES-Key Professional software as a *switch input* module (device type 2), or as a *switch input/output* module (device type 4) depending on the position of the selector switch used for device type identification (see section 3.4.1).

#### 3.4.1. Device type selection

The device type is selected by setting the selection switch (located inside of the case) to the desired position. The switch is labeled DEVICE and is directly related to the device type. When the switch is down it is a device type 4. When the switch is up it is a device type 2.

The address for both versions is selected by rotating the address switch to the desired value (0-15). Address 9 has special functionality (see section 3.4.2). Use an address selection tool (or a #1 Philips screwdriver) to set the position of the switch to the desired address.

(Note: Selection switches are only read at power up).

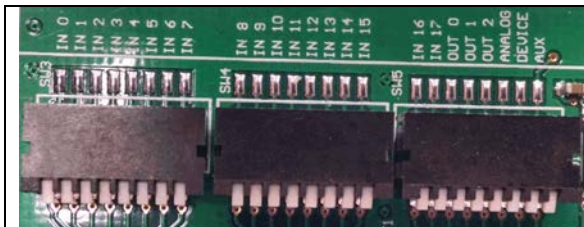

Figure 11. Selection switches.

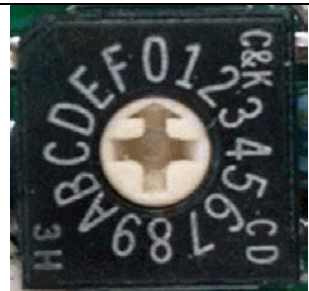



Figure 12. Address switch



Figure 13 Address selection tool.

  607 NW 27th Ave Ocala, FL 34475 Phone : (352) 629-5020 Fax : (352)-629-2902	FOR EXTERNAL DISTRIBUTION			PAGE	7 of 13
	<b>OPERATION MANUAL</b>			DATE	9/05/2014
PRODUCT GROUP	ES-Key	P/N	FSG-MNL-00108	REV	1.00
PRODUCT	<b>18 input module with 3 outputs</b>			BY	GMC

### 3.4.2. Special address 9 (vocation module feature)

A 18 Input Module set to address 9 reports the states of its eighteen (18) inputs to the ES-Key network normally, but also sends an additional message to the ES-Key network for the first 8 inputs (input address 0-7) as a vocation module. A vocation module in the ES-Key database allows interlocking outputs to vocation inputs (park brake, neutral, pump shift, pump engaged, etc).

A vocation module must be included in the ES-Key Professional database to take advantage of the special address 9 feature (only one vocation module type is allowed in an ES-Key network and database).

Add a vocation module to the database with the ES-Key Professional software by right clicking "ES-Key Network" in the device window, and then select *Add Device*, and then *Vocation Module*.

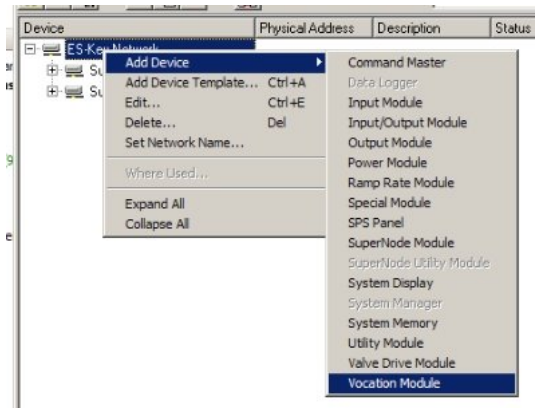

Figure 14. Adding a vocation module.

Double-click on the newly created vocation module in the device window and the *Device Editor – Vocation* window will appear. Click on the *Vocation* tab to select one of the three vocation input types.

- No vocation
- Split-Shaft PTO
- User Defined

**No Vocation** does not allow the eight (8) vocation inputs to be used in the system.

**Split-Shaft PTO** sets the eight (8) vocation inputs to predetermined functions (refer to section **Error! Reference source not found.** for input mapping).

**User Defined** allows the eight (8) vocation inputs to be defined by the user.

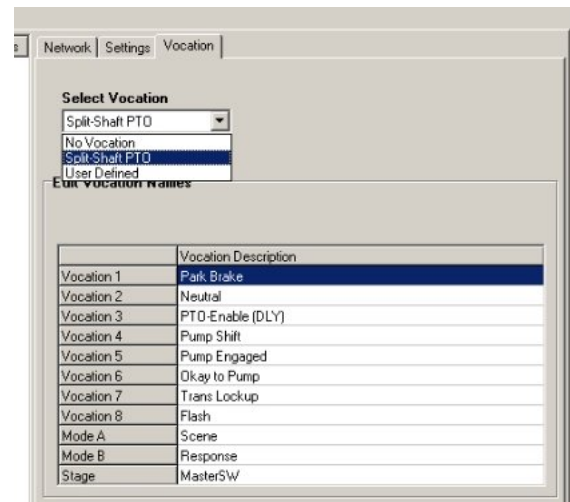



Figure 15. Selecting vocation inputs.



  607 NW 27th Ave Ocala, FL 34475 Phone : (352) 629-5020 Fax : (352)-629-2902	FOR EXTERNAL DISTRIBUTION			PAGE	8 of 13
	<b>OPERATION MANUAL</b>			DATE	9/05/2014
PRODUCT GROUP	ES-Key	P/N	FSG-MNL-00108	REV	1.00
PRODUCT	<b>18 input module with 3 outputs</b>			BY	GMC

Apply vocation inputs to database outputs by selecting the desired output and opening the *Device Editor* window. Right-click on the *Vocation Interlock* text, *Add Interlock*, and then select the desired vocation interlock to tie to the database output.

The list of vocation interlocks is determined by the vocation method selected (Split-Shaft PTO, or User Defined).

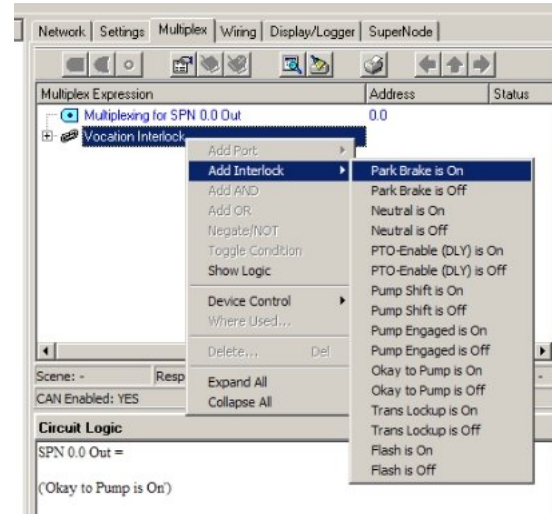

Figure 16. Applying vocation inputs.

### 3.5. Input/output memory space

The 18 Input Module uses standard ES-Key defined input and output memory space. The polarity selectable inputs are mapped into the input space, and the polarity selectable outputs are mapped into the output space.



INPUT MEMORY SPACE		
INPUT	DESCRIPTION	
0	Physical input 0 <sup>(1)</sup>	[Park Brake] <sup>(2)</sup>
1	Physical input 1 <sup>(1)</sup>	[Neutral] <sup>(2)</sup>
2	Physical input 2 <sup>(1)</sup>	[PTO-Enable DLY] <sup>(2)</sup>
3	Physical input 3 <sup>(1)</sup>	[Pump Shift] <sup>(2)</sup>
4	Physical input 4 <sup>(1)</sup>	[Pump Engaged] <sup>(2)</sup>
5	Physical input 5 <sup>(1)</sup>	[Okay to Pump] <sup>(2)</sup>
6	Physical input 6 <sup>(1)</sup>	[Trans Lockup] <sup>(2)</sup>
7	Physical input 7 <sup>(1)</sup>	[Flash] <sup>(2)</sup>
8	Physical input 8	
9	Physical input 9	
10	Physical input 10	
11	Physical input 11	
12	Physical input 12	
13	Physical input 13	
14	Physical input 14	
15	Physical input 15	
16	Physical input 16	
17	Physical input 17	

OUTPUT MEMORY SPACE	
OUTPUT	LOCATION
0	Physical output 0 <sup>(3)</sup>
1	Physical output 1 <sup>(3)</sup>
2	Physical output 2 <sup>(3)</sup>

<sup>(1)</sup> The first eight inputs also have special functionality when configured as a vocation module (address 9).

<sup>(2)</sup> These input names are valid only when the module's address is set to 9 (vocation module) and "Split-Shaft PTO" vocation is selected with the ES-Key Professional software (refer to section 3.4.2).

<sup>(3)</sup> These outputs are only available if selected and the device type is set for (device type 4).

  607 NW 27th Ave Ocala, FL 34475 Phone : (352) 629-5020 Fax : (352)-629-2902	<b>FOR EXTERNAL DISTRIBUTION</b>			<b>PAGE</b>	9 of 13	
	<b>OPERATION MANUAL</b>				<b>DATE</b>	9/05/2014
	<b>PRODUCT GROUP</b>	ES-Key	<b>P/N</b>	FSG-MNL-00108	<b>REV</b>	1.00
<b>PRODUCT</b>	<b>18 input module with 3 outputs</b>			<b>BY</b>	<b>GMC</b>	

## 4. Connector Description

The module has two connectors and the following definitions apply:

### 4.1. Connector A (gray)

Mating connector: Deutsch DTM06-12SA (GRAY) Mating sockets: 0462-201-20141 Wedge lock: WM12S Recommended wire gage: 18-24 AWG		
PIN	CIRCUIT	DESCRIPTION
1	Supply +	Module supply (+9VDC...+32VDC) [fused 750mA]
2	CAN High	ES-Key CAN, SAE J1939 Proprietary, 250 kbits/S
3	CAN Shield	ES-Key CAN, SAE J1939 Proprietary, 250 kbits/S
4	Input 16 / Output 0	Digital input (polarity selectable – positive or ground) Digital output (polarity selectable – positive or ground)
5	Input 12	Digital input (polarity selectable – positive or ground)
6	Input 14	Digital input (polarity selectable – positive or ground)
7	Input 15	Digital input (polarity selectable – positive or ground)
8	Input 13	Digital input (polarity selectable – positive or ground)
9	Input 17 / Output 1	Digital input (polarity selectable – positive or ground) Digital output (polarity selectable – positive or ground)
10	Analog / Output2	Analog Input (0-5 volt – 4-20mA) Digital output (polarity selectable – positive or ground)
11	CAN Low	ES-Key CAN, SAE J1939 Proprietary, 250 kbits/S
12	Supply -	Module supply (vehicle ground)

### 4.2. Connector B (black)

Mating connector: Deutsch DTM06-12SB (BLACK) Mating sockets: 0462-201-20141 Wedge lock: WM12S Recommended wire gage: 18-24 AWG		
PIN	CIRCUIT	DESCRIPTION
1	Input 11	Digital input (polarity selectable – positive or ground)
2	Input 9	Digital input (polarity selectable – positive or ground)
3	Input 7	Digital input (polarity selectable – positive or ground)
4	Input 5	Digital input (polarity selectable – positive or ground)
5	Input 3	Digital input (polarity selectable – positive or ground)
6	Input 1	Digital input (polarity selectable – positive or ground)
7	Input 0	Digital input (polarity selectable – positive or ground)
8	Input 2	Digital input (polarity selectable – positive or ground)
9	Input 4	Digital input (polarity selectable – positive or ground)
10	Input 6	Digital input (polarity selectable – positive or ground)
11	Input 8	Digital input (polarity selectable – positive or ground)
12	Input 10	Digital input (polarity selectable – positive or ground)

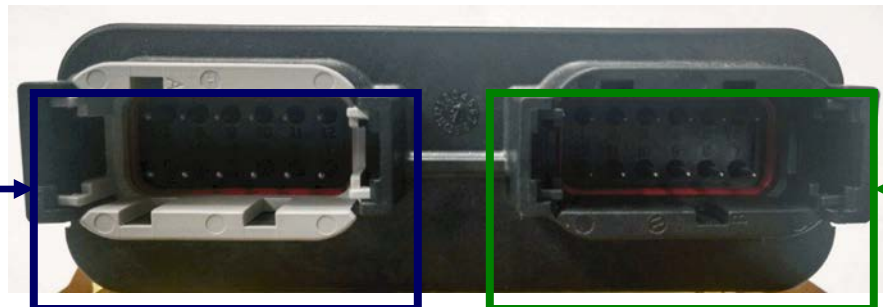



Figure 17. Connector Identification.

  607 NW 27th Ave Ocala, FL 34475 Phone : (352) 629-5020 Fax : (352)-629-2902	FOR EXTERNAL DISTRIBUTION			PAGE	10 of 13
	<b>OPERATION MANUAL</b>			DATE	9/05/2014
PRODUCT GROUP	ES-Key	P/N	FSG-MNL-00108	REV	1.00
PRODUCT	<b>18 input module with 3 outputs</b>			BY	GMC

#### 4.2.1. Terminating resistor requirement (CAN communication)

Two terminating resistors (120 Ohm) are required on the CAN bus for proper operation (one at each end of the CAN bus). Only two terminating resistors are allowed on a CAN bus.

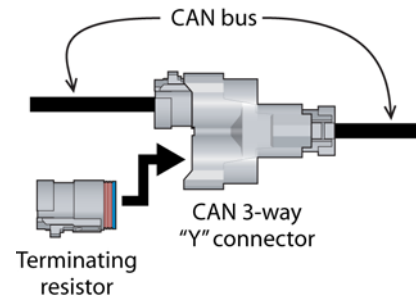

Terminating resistor            p/n DT06-3S-P006

CAN 3-way "Y" connector    p/n DT04-3P-P007



#### 4.3. System compatibility

The 18 Input Module is compatible with other Class 1 CAN devices.

  607 NW 27th Ave Ocala, FL 34475 Phone : (352) 629-5020 Fax : (352)-629-2902	FOR EXTERNAL DISTRIBUTION <b>OPERATION MANUAL</b>			PAGE 11 of 13
	PRODUCT GROUP ES-Key	P/N FSG-MNL-00108	DATE 9/05/2014	
PRODUCT 18 input module with 3 outputs	REV 1.00	BY GMC		

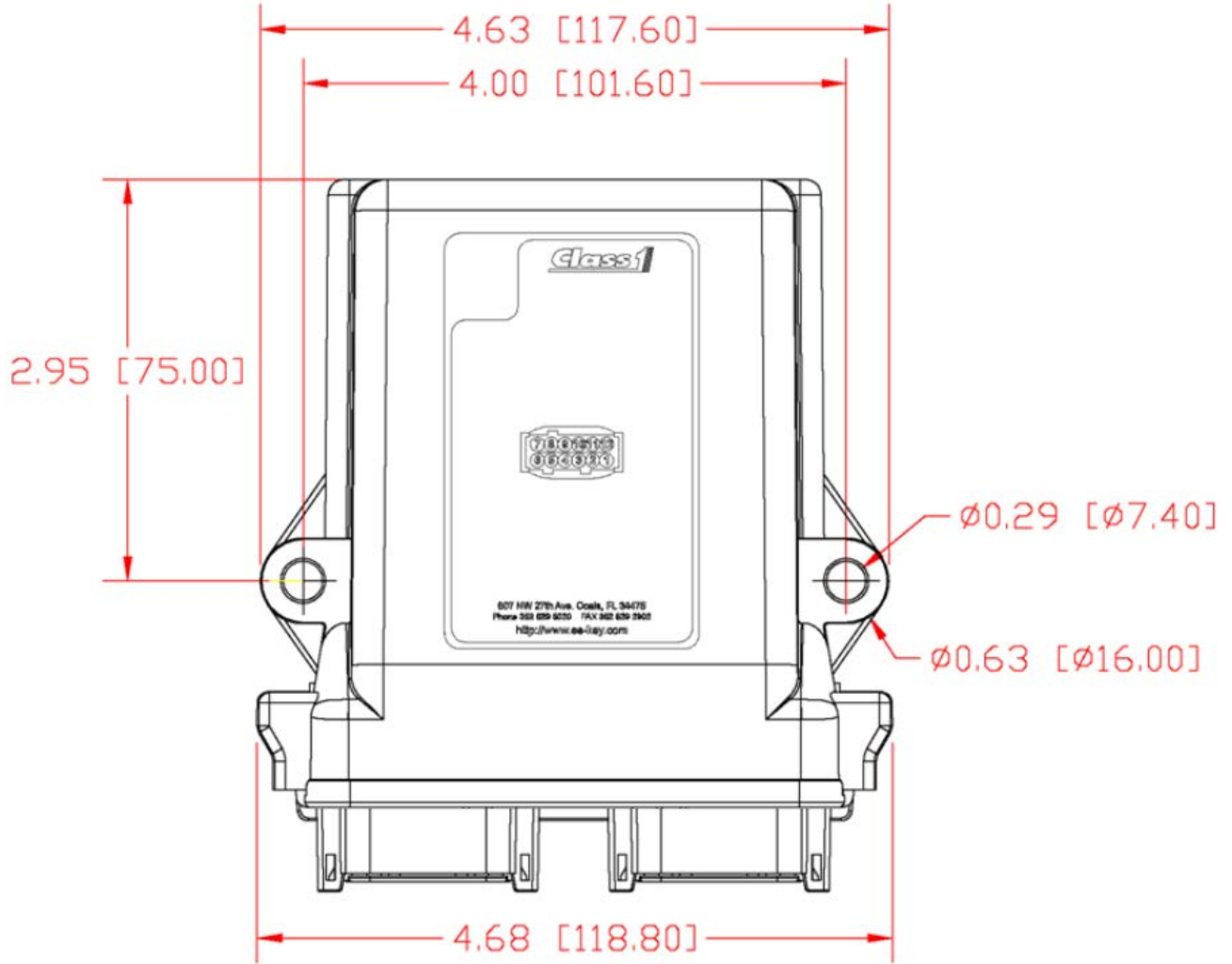

## 5. Mounting

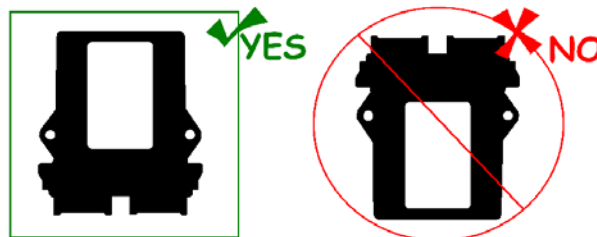

Mounting and package dimensions – inches [millimeters].

**NOTE:** When mounting the module vertically, make certain the connectors are pointed down so as to eliminate the possibility of standing water in the connector.



  607 NW 27th Ave Ocala, FL 34475 Phone : (352) 629-5020 Fax : (352)-629-2902	FOR EXTERNAL DISTRIBUTION <b>OPERATION MANUAL</b>			PAGE	12 of 13
	PRODUCT GROUP	ES-Key	P/N	FSG-MNL-00108	DATE
PRODUCT	18 input module with 3 outputs			REV	1.00
				BY	GMC

## 6. Diagnostics

The **18 digital, 1 analog input module** has 3 diagnostic LEDs which are viewable through the top of its amber enclosure.

**PWR** - +5VDC logic power  
**BUS** - +9...+32VDC Module power  
**COM** - Module status indicator

The COM LED indicates the module's CAN communication status.

**On Solid**  
 Module on-line



**Flashing slow (2Hz)**  
 CAN bus okay, but the module is not receiving messages from the Universal System Manager (USM).

**Flashing fast (8Hz)**  
 CAN bus error, no communications or not connected.

**Flashing fast (20Hz)**  
 Output Over Current Indication

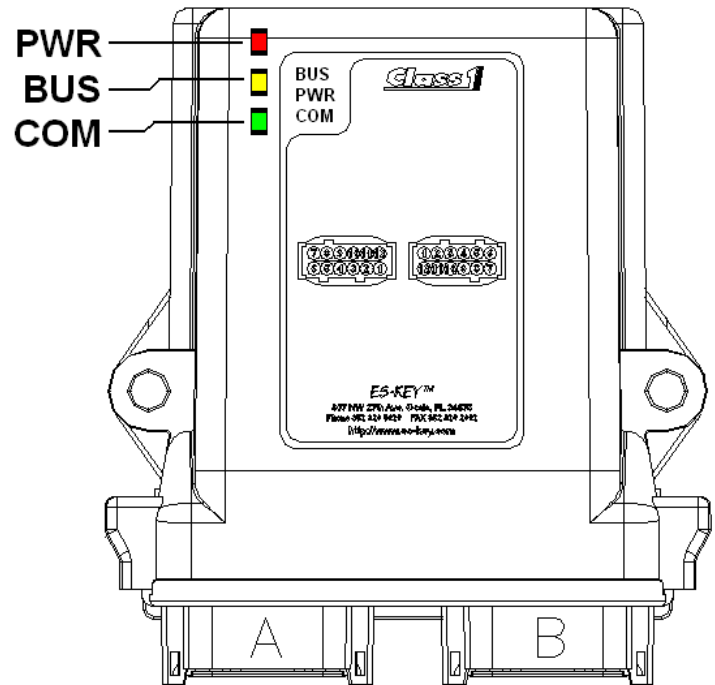
**Double flash**  
 CAN bus has an *ACTIVE* error, no communications.



  607 NW 27th Ave Ocala, FL 34475 Phone : (352) 629-5020 Fax : (352)-629-2902	FOR EXTERNAL DISTRIBUTION			PAGE	13 of 13	
	<b>OPERATION MANUAL</b>			DATE	9/05/2014	
	PRODUCT GROUP	ES-Key	P/N	FSG-MNL-00108	REV	1.00
	PRODUCT	<b>18 input module with 3 outputs</b>			BY	GMC

## 7. Glossary

<b>LED</b>	<u>L</u> ight <u>E</u> mitting <u>D</u> iode. The lights on the display used to show tank level and information.
<b>CAN</b>	<u>C</u> ontroller <u>A</u> rea <u>N</u> etwork. SAE J1939 communication method.
<b>EEPROM</b>	<u>E</u> lectrically <u>E</u> rasable <u>P</u> rogrammable <u>R</u> ead- <u>O</u> nly <u>M</u> emory. The memory of the tank level display, used to store the display information (tank level points, display type, dim value, etc).
<b>OEM</b>	<u>O</u> riginal <u>E</u> quipment <u>M</u> anufacturer.
<b>SAE</b>	<u>S</u> ociety of <u>A</u> utomotive <u>E</u> ngineers.
<b>ESD</b>	<u>E</u> lectro <u>S</u> tatic <u>D</u> ischarge.
<b>IP</b>	<u>I</u> ngress <u>P</u> rotection (IP 67, etc).
<b>p/n</b>	part number

## 8. Technical details

Product category	ES-KEY
Voltage range	+9VDC...+32VDC
Power consumption	Logic supply+ input (pin 1)
@13.8VDC	62mA <sup>(1)</sup>
@27.6VDC	83mA <sup>(1)</sup>
Output current capability	25mA per output
Input current draw	2mA per input (positive or ground polarity)
Operational temperature range	-40°C...+85°C
Environmental range	IP 67
CAN specification	SAE J1939 proprietary, 250 Kbits/second
Protection	Internal thermal fuse (750mA on pin 1)
	Reverse voltage protection (pins 1 and 12)
	CAN buses protected to 24V
	ESD voltage protected to SAE J1113 specification for heavy duty trucks (24V)
	Transient voltage protected to SAE J1113 specification for heavy duty trucks (24V)
Dimensions (W x L x H) in inches [mm]	Load dump voltage protected to SAE J1113 specification for heavy duty trucks (24V)
	Outputs protected for short circuit and thermal overload
Dimensions (W x L x H) in inches [mm]	4.680 [118.80] x 5.240 [133.10] x 1.420 [36.07]

<sup>(1)</sup> Does not include current draw due to connected external loads on outputs 0, 1, and 2.

### 8.1. WEEE (Waste of Electrical and Electronic Equipment) directive



This symbol [crossed-out wheeled bin WEEE Annex IV] indicates separate collection of waste electrical and electronic equipment in the European Union countries.

Please do not throw the equipment into the domestic refuse.

Each individual European Union member state has implemented the WEEE regulations into national law in slightly different ways. Please follow your national law when you want to dispose of any electrical or electronic products.

**More details can be obtained from your national WEEE recycling agency.**