



Class 1

ISO 9001 CERTIFIED

607 NW 27th Ave
Ocala, FL 34475
Phone: (352) 629-5020 or 800-533-3569
Fax: (352)-629-2902

SUITABLE FOR EXTERNAL DISTRIBUTION

TECHNICAL PRODUCT DATASHEET

Sentry Pressure Governor

P/N 3045-101-00-CL1
P/N 3045-102-00-CL1



 607 NW 27th Ave Ocala, FL 34475 Ph: 352-629-5020 or 1-800-533-3569 Fax: 352-629-2902 or 1-800-520-3473	TECHNICAL DATA SHEET			PAGE	1 OF 36
	PRODUCT GROUP	THROTTLE CONTROL	P/N	3045-101-00-CL1, 3045-102-00-CL1	DATE
PRODUCT	SENTRY PRESSURE GOVERNOR			REV	1.14
				BY	IMC

- 1. REVISION LOG 4**
- 2. SYSTEM OVERVIEW 5**
 - 2.1. SYSTEM PART NUMBERS 5
 - 2.2. WIRING DETAIL 5
- 3. OVERVIEW OF THE SENTRY GOVERNOR 6**
 - 3.1. MODE AND INTERLOCK INDICATORS 7
 - 3.2. PUMP DISCHARGE PRESSURE DISPLAY 7
 - 3.3. PUMP INTAKE PRESSURE DISPLAY 7
 - 3.4. MODE, PRESET, INCREASE, DECREASE AND IDLE BUTTONS 7
 - 3.4.1. *IDLE* 7
 - 3.4.2. *PRESET 1* 7
 - 3.4.3. *PRESET 2* 7
 - 3.4.4. *MODE* 7
 - 3.4.5. *INCREASE* 7
 - 3.4.6. *DECREASE* 7
 - 3.5. "SOFT" BUTTONS 8
 - 3.6. INFORMATION DISPLAYS 8
 - 3.6.1. *Engine RPM display* 8
 - 3.6.2. *Battery voltage display* 8
 - 3.6.3. *Coolant temperature display* 8
 - 3.6.4. *Oil pressure display* 8
 - 3.6.5. *Transmission temperature display* 8
 - 3.6.6. *Fuel economy display* 8
- 4. OPERATION 9**
 - 4.1. INITIALIZATION 9
 - 4.2. OPERATING MODE SELECTION 10
 - 4.2.1. *Throttle mode* 10
 - 4.2.2. *Pressure mode* 11
 - 4.2.3. *High Idle mode* 12
 - 4.2.4. *Pressure mode control parameters* 13
 - 4.3. REQUIRED INTERLOCKING 13
 - 4.4. PRESET BUTTON OPERATION 13
 - 4.5. IDLE BUTTON OPERATION 14
- 5. WARNING AND ERROR MESSAGES 15**
 - 5.1. FIRST LEVEL MESSAGE INFORMATION (OPERATOR) 15
 - 5.2. SECOND LEVEL MESSAGE INFORMATION (TECHNICIAN) 16
 - 5.3. LIST OF WARNING/ERROR MESSAGES 16
 - 5.3.1. *Intake or Discharge Sensor Fault* 19
 - 5.3.2. *Water Supply Insufficient, Discharge Pressure Less Than 30 Psi, and Critical: Sentry In Stand By. Check Water Source* 19
 - 5.3.3. *Unable To Maintain Discharge Pressure* 19
 - 5.3.4. *Discharge Pressure Has Increased More Than 50 Psi Since Setting Rpm* 19
 - 5.3.5. *Communication with engine is lost* 20
- 6. SENTRY SETUP MENUS 21**
 - 6.1. ENGINE COMPATIBILITY 21
 - 6.2. ENTER THE SETUP MENU 21
 - 6.2.1. *Menu soft buttons* 21
 - 6.3. PASSWORD ENTRY SCREEN 22
 - 6.3.1. *Reset the Pump Hours* 22

 607 NW 27th Ave Ocala, FL 34475 Ph: 352-629-5020 or 1-800-533-3569 Fax: 352-629-2902 or 1-800-520-3473	TECHNICAL DATA SHEET			PAGE	2 OF 36	
				DATE	11/26/2019	
	PRODUCT GROUP	THROTTLE CONTROL	P/N	3045-101-00-CL1, 3045-102-00-CL1	REV	1.14
	PRODUCT	SENTRY PRESSURE GOVERNOR			BY	IMC

6.3.2.	USB Bootloader.....	22
6.3.3.	Save Menu Items to a USB thumb drive.....	22
6.3.4.	Load Menu Items from a USB thumb drive.....	22
6.4.	INFO MENU.....	23
6.4.1.	Reset the Auxiliary Hours.....	23
6.4.2.	Zero Calibrate the pressure sensors.....	23
6.4.3.	Set Factory Defaults.....	23
6.4.4.	Autoscale Analog Output.....	23
6.5.	USER MENU.....	24
6.5.1.	Change the unit of measure.....	25
6.5.2.	Change the Preset RPM 1.....	25
6.5.3.	Change the Preset Pressure 1.....	25
6.5.4.	Change the Preset RPM 2.....	25
6.5.5.	Change the Preset Pressure 2.....	25
6.5.6.	Change the Display Brightness (day mode).....	25
6.5.7.	Change the Display Brightness (night mode).....	25
6.5.8.	Round pressure.....	25
6.5.9.	Change the Display Mode (Day or Night).....	25
6.6.	COMMAND MENU.....	26
6.6.1.	Positive Twister Direction.....	26
6.6.2.	Display Fuel Economy.....	26
6.6.3.	Display Transmission Temperature.....	26
6.6.4.	Display Oil Pressure.....	26
6.6.5.	Display Discharge Pressure.....	26
6.6.6.	Display Intake Pressure.....	26
6.6.7.	Iconography.....	26
6.6.8.	High Idle Preset.....	27
6.7.	OEM 1 MENU.....	27
6.7.1.	Warning Source.....	27
6.7.2.	Coolant Temperature Warning (USER).....	27
6.7.3.	Coolant Temperature Critical (USER).....	27
6.7.4.	Oil Pressure Warning (USER).....	27
6.7.5.	Oil Pressure Critical (USER).....	27
6.7.6.	Warning Voltage 12V.....	28
6.7.7.	Critical Voltage 12V.....	28
6.7.8.	Warning Voltage 24V.....	28
6.7.9.	Critical Voltage 24V.....	28
6.8.	OEM 2 MENU.....	28
6.8.1.	Sensitivity (pressure).....	28
6.8.2.	Intake Offset Pressure.....	28
6.8.3.	Discharge Offset Pressure.....	29
6.8.4.	Intake Sensor Range.....	29
6.8.5.	Discharge Sensor Range.....	29
6.8.6.	Intake Threshold.....	29
6.8.7.	Pressure Time-Out (Seconds).....	29
6.8.8.	Pressure Gain (pressure change per step).....	29
6.8.9.	LAG (PSI/kPa/Bar).....	29
6.9.	OEM 3 MENU.....	30
6.9.1.	First Operating Mode.....	30
6.9.2.	Inhibit RPM Presets.....	30
6.9.3.	Idle Engine Speed (RPM).....	30
6.9.4.	Maximum Engine Speed (RPM).....	30
6.9.5.	Governor Gain (RPM per volt).....	30
6.9.6.	DITHER (Engine handshake).....	31
6.9.7.	Max Pressure.....	31

 607 NW 27th Ave Ocala, FL 34475 Ph: 352-629-5020 or 1-800-533-3569 Fax: 352-629-2902 or 1-800-520-3473	TECHNICAL DATA SHEET			PAGE	3 OF 36
				DATE	11/26/2019
PRODUCT GROUP	THROTTLE CONTROL	P/N	3045-101-00-CL1, 3045-102-00-CL1	REV	1.14
PRODUCT	SENTRY PRESSURE GOVERNOR			BY	IMC

6.9.8.	Inhibit Presets by Pressure	31
6.9.9.	Voltage Adjust	31
6.10.	OEM 4 MENU	32
6.10.1.	Max Rate of RPM Change	32
6.10.2.	RPM Gain Integrator	32
6.10.3.	Max Rate of Pressure Change	32
6.10.4.	Pressure Gain Integrator	32
6.11.	FACT MENU 1	33
6.11.1.	Battery Voltage Range	33
6.11.2.	Engine Control Method	33
6.11.3.	CAN Source ID	33
6.11.4.	Display Orientation	34
6.11.5.	Slave Orientation	34
6.11.6.	Language	34
6.11.7.	Baud Rate	34
6.11.8.	Ok to Pump Mode	34
6.11.9.	Twister Enable	34
6.12.	FACT MENU 2	34
6.12.1.	Set the Warning Alert Tone	35
6.12.2.	Volts Yellow Warn	35
6.12.3.	Auto Mode	35
6.12.4.	Idle Voltage	35
6.12.5.	BCM1 VER (Body Control Message 1 version)	35
6.12.6.	Scania Mode (Scania governor type)	35
6.12.7.	SPN 696	35
6.12.8.	Alarms behind OEM Interlock	36
6.12.9.	Control Mode	36
7.	CONFIGURATION	36
7.1.	CONFIGURE THE IDLE VOLTAGE AND GAIN SETTING USING AUTO SCALE (ANALOG ENGINES)	36
8.	USING A TWISTER WITH THE SENTRY	37
8.1.	OVERVIEW	37
8.2.	READY INDICATOR	37
8.3.	ACTIVE INDICATOR	37
8.4.	CONTROL KNOB	37
8.5.	IDLE BUTTON	37
8.6.	TWISTER OPERATION IN SENTRY MODES	38
8.6.1.	Throttle mode operation	38
8.6.2.	Pressure mode	38
8.6.3.	High Idle mode	38
8.7.	LIST OF WARNING/ERROR MESSAGES	39
8.8.	CONFIGURE THE TWISTER FOR OPERATION WITH THE SENTRY	39
9.	MOUNTING & INSTALLATION	40
9.1.	PANEL CUTOUT DIMENSIONS (SENTRY)	40
9.2.	PANEL CUTOUT DIMENSIONS (TWISTER)	40
10.	CONNECTOR DESCRIPTION	41
10.1.	SENTRY CONNECTORS	41
10.2.	PRESSURE SENSOR CONNECTOR	42
10.3.	TWISTER CONNECTOR	42
11.	TECHNICAL DETAILS	43

 607 NW 27th Ave Ocala, FL 34475 Ph: 352-629-5020 or 1-800-533-3569 Fax: 352-629-2902 or 1-800-520-3473	TECHNICAL DATA SHEET			PAGE	4 OF 36	
	PRODUCT GROUP	THROTTLE CONTROL	P/N	3045-101-00-CL1, 3045-102-00-CL1	DATE	11/26/2019
	PRODUCT	SENTRY PRESSURE GOVERNOR			REV	1.14
					BY	IMC

1. Revision Log

Rev	Date	Changes
1.00	2/19/2013	Initial revision
1.01	6/19/2014	Updated function of blue LED on Twister.
1.02	7/16/2014	Added new factory menu options for version 1.5g
1.03	9/22/2014	Added new factory menu options for version 1.5j
1.04	11/6/2014	Added note regarding wiring detail
1.05	03/16/2015	Corrected part number for the Connector Wedge Lock used in Connector A and D
1.06	06/3/2015	Added new OEM2/factory menu options for version 1.5n
1.07	02/3/2016	Added Factory Items and Changed wording on Menu Items.
1.08	07/29/2016	Added new features to Sentry 2.0
1.09	12/13/2017	Added Password Entry Screen detail and High Idle Enable for Sentry 2e
1.10	5/18/2018	Adjusted Factory 1 and 2 menus, updated Sentry Graphics, split out Twister instructions
1.11	6/11/2018	Added OEM Menu 4 and new menu items.
1.12	10/15/2018	Removed secondary slave Twister setup instructions.
1.13	4/3/2019	Added new menu items in OEM Menu 4 (MH)
1.14	11/26/19	Added SB-143 to end of file



Product specifications in this manual are subject to change without notice.

 607 NW 27th Ave Ocala, FL 34475 Ph: 352-629-5020 or 1-800-533-3569 Fax: 352-629-2902 or 1-800-520-3473	TECHNICAL DATA SHEET			PAGE	5 OF 36	
	PRODUCT GROUP	THROTTLE CONTROL	P/N	3045-101-00-CL1, 3045-102-00-CL1	DATE	11/26/2019
	PRODUCT	SENTRY PRESSURE GOVERNOR			REV	1.14
					BY	IMC

2. System Overview

2.1. System part numbers

Sentry Pressure Governor system kit, vertical	599-00010-001
Sentry Pressure Governor system kit, horizontal	599-00010-002
Sentry Pressure Governor, vertical	3045-101-00-CL1
Sentry Pressure Governor, horizontal	3045-102-00-CL1

Kit includes

Sentry Pressure Governor, vertical	QTY-1	3045-101-00-CL1
OR Sentry Pressure Governor, horizontal	QTY-1	3045-102-00-CL1
Twister Control Knob	QTY-1	119970
Sentry system harness	QTY-1	513-00019
Sentry Label, vertical	QTY-1	122482-001
OR Sentry Label, horizontal	QTY-1	122481-001
Transducer 0-300 PSI	QTY-2	200-00092

Optional items

Transducer 0-600 PSI	200-00108
----------------------	-----------

Documentation (available from Class 1's website - www.class1.com)

Engine compatibility guide	117686
----------------------------	--------

2.2. Wiring detail

Below is the point-to-point wiring of the Sentry. The circuits with the yellow background are for analog control of the engine ECU and are optional.

NOTE: To Include a Twister Throttle module simply connect it's CAN port connection to the same CAN network the Sentry is Connected to.

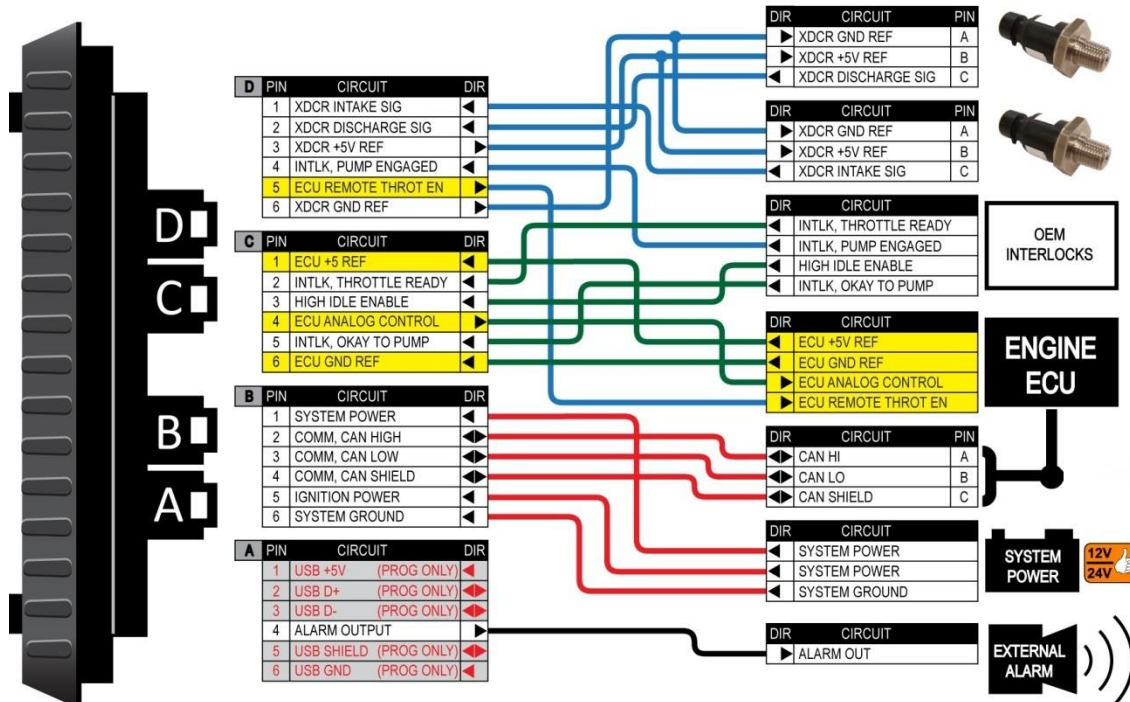



Figure 1. Wiring detail.

 607 NW 27th Ave Ocala, FL 34475 Ph: 352-629-5020 or 1-800-533-3569 Fax: 352-629-2902 or 1-800-520-3473	TECHNICAL DATA SHEET			PAGE	6 OF 36	
				DATE	11/26/2019	
	PRODUCT GROUP	THROTTLE CONTROL	P/N	3045-101-00-CL1, 3045-102-00-CL1	REV	1.14
	PRODUCT	SENTRY PRESSURE GOVERNOR			BY	IMC

3. Overview of the Sentry Governor

The Sentry Governor (p/n 3045-101-00-CL1 vertical, p/n 3045-102-00-CL1 horizontal) is an SAE J1939 Controller Area Network (CAN) device that controls engine speed using data communications directly to the engine ECU or through with an analog control signal. By operating on the J1939 network, the governor is able to monitor engine RPM and other pertinent data directly from the engine ECU. Engine information is available directly so that NFPA required instrumentation is delivered through a single unit saving panel space and delivering engine specific warnings as determined by each engine manufacturer.

Control algorithms are optimized to take advantage of the J1939 CAN data to yield crisp and accurate control of engine and subsequently pump speed and pressure output.

For engines that may not support the data link control, an analog output signal is available to provide precise control of the engine speed and pressure.

The SENTRY saves pump panel space by incorporating easy to read numeric displays for Pump Intake pressure, Pump Discharge pressure, and engine RPM in accordance with NFPA standards.

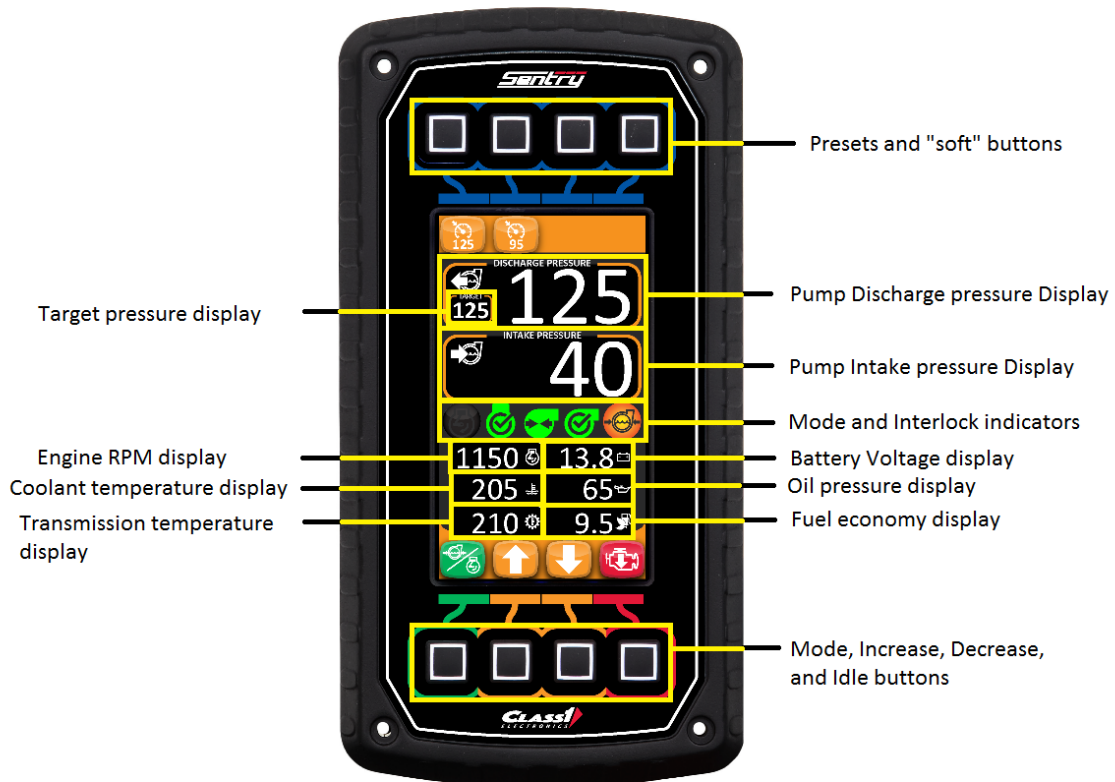



Figure 2. Sentry controls and indicators.

 607 NW 27th Ave Ocala, FL 34475 Ph: 352-629-5020 or 1-800-533-3569 Fax: 352-629-2902 or 1-800-520-3473	TECHNICAL DATA SHEET			PAGE	7 OF 36
				DATE	11/26/2019
	PRODUCT GROUP	THROTTLE CONTROL	P/N	3045-101-00-CL1, 3045-102-00-CL1	
	PRODUCT	SENTRY PRESSURE GOVERNOR			REV
				BY	IMC

3.1. Mode and Interlock indicators

Green icons indicate the status of the three (3) interlocks: *throttle ready*, *pump engaged*, and *okay to pump*. The mode indicators consist of two (2) icons to show the governor's current operating mode. The PRESSURE MODE ICON (yellow) indicates the governor is operating in **pressure mode** and the RPM MODE ICON (blue) indicates the governor is operating in **throttle mode**. When both icons are OFF the governor is in **idle mode** (standby).

3.2. Pump discharge pressure display

The pump discharge pressure display shows the pressure as determined by the discharge pressure sensor. By default, this display only shows positive pressure in pounds per square inch (PSI), but it may be set up to display in metric units (see section 6.5.1).

3.3. Pump intake pressure display

The pump intake pressure display shows the pressure as determined by the intake pressure sensor. By default, this display shows positive pressure in pounds per square inch (PSI) and negative pressure (vacuum) in inches of mercury (in Hg), but it may be set up to display in metric units (see section 6.5.1).

3.4. Mode, Preset, Increase, Decrease and Idle buttons

The six (6) control buttons are color coded and labeled for easy identification.

3.4.1. IDLE

The IDLE switch (red) forces the governor to **idle mode** (standby). Pressing and holding this button for **one second** while in rpm mode or pressure mode will cause the engine to ramp down to its idle position.

3.4.2. PRESET 1

The PRESET 1 button sets the governor to the configured preset 1 engine RPM while in **throttle mode**, or preset pressure while in **pressure mode**.

3.4.3. PRESET 2

The PRESET 2 button sets the governor to the configured preset 2 engine RPM while in **throttle mode**, or preset pressure while in **pressure mode**.

3.4.4. MODE

The MODE button (green) sets the governor to either **throttle mode** (RPM) or **pressure mode** (PSI). The correct interlocks must be present for the system to begin governor operation: throttle ready for RPM mode, throttle ready, pump engaged, and okay to pump for PSI mode.

3.4.5. INCREASE

The INCREASE button (orange) increases the RPM or PSI target per button press while in either **throttle mode** (RPM) or **pressure mode** (PSI) respectively.

3.4.6. DECREASE

The DECREASE button (orange) decreases the RPM or PSI target per button press while in either **throttle mode** (RPM) or **pressure mode** (PSI) respectively.

 607 NW 27th Ave Ocala, FL 34475 Ph: 352-629-5020 or 1-800-533-3569 Fax: 352-629-2902 or 1-800-520-3473	TECHNICAL DATA SHEET			PAGE	8 OF 36	
	PRODUCT GROUP	THROTTLE CONTROL	P/N	3045-101-00-CL1, 3045-102-00-CL1	DATE	11/26/2019
	PRODUCT	SENTRY PRESSURE GOVERNOR			REV	1.14
					BY	IMC

3.5. “Soft” buttons

The two (2) soft buttons have functions based on the current operating mode and/or warning messages display. These buttons are typically used for menu navigation, configuration, and warning message evaluations.

3.6. Information displays

The Sentry has six (6) information displays.

3.6.1. Engine RPM display

The engine RPM display shows the current engine RPM as reported by the Electronic Engine Controller 1 (EEC1) SAE J1939 network data message transmitted by the vehicle ECU.

3.6.2. Battery voltage display

The battery voltage display shows the current system voltage as determined by the voltage present on pin 1 of connector B.

3.6.3. Coolant temperature display

The coolant temperature display shows the current coolant system temperature as reported by the Electronic Engine Temperature 1 (ET1) SAE J1939 network data message transmitted by the vehicle ECU. The temperature will be displayed in degrees Fahrenheit (°F) or degrees Celsius (°C) dependent on the unit of measure configured in the setup menu (see section 6.5.1)

3.6.4. Oil pressure display

The oil pressure display shows the current oil pressure as reported by the engine Fluid Level/Pressure 1 (EFL/P1) SAE J1939 network data message transmitted by the vehicle ECU. The pressure will be displayed in PSI, kPa, or Bar dependent on the unit of measure configured in the setup menu (see section 6.5.1)

3.6.5. Transmission temperature display

The transmission temperature display shows the transmission oil temperature as reported by the Transmission Fluids 1 (TRF1) SAE J1939 network data message transmitted by the vehicle TCU. The temperature will be displayed in degrees Fahrenheit (°F) or degrees Celsius (°C) dependent on the unit of measure configured in the setup menu (see section 6.5.1)

3.6.6. Fuel economy display

The fuel economy display shows the current fuel usage per hour as reported by the Fuel Economy, Liquid (LFE1) SAE J1939 network data message transmitted by the vehicle ECU. The fuel economy will be displayed in gallons per hour (G/h) or liters per hour (L/h) dependent on the unit of measure configured in the setup menu (see section 6.5.1)

 607 NW 27th Ave Ocala, FL 34475 Ph: 352-629-5020 or 1-800-533-3569 Fax: 352-629-2902 or 1-800-520-3473	TECHNICAL DATA SHEET			PAGE	9 OF 36
				DATE	11/26/2019
PRODUCT GROUP	THROTTLE CONTROL	P/N	3045-101-00-CL1, 3045-102-00-CL1	REV	1.14
PRODUCT	SENTRY PRESSURE GOVERNOR			BY	IMC

4. Operation

4.1. Initialization

The SENTRY has a six (6) second power initialization cycle and during this time the display will show:

The SENTRY displays a black screen with the word "Booting...." For 4 seconds after a power cycle.



The SENTRY shows the Sentry logo for the next 4 seconds.





The Sentry shows the version and configuration for the last 4 seconds. The last letter of this display indicates the configured control method of the SENTRY.

- TPG-C – CFPG control method
- TPG-P – PGN0 control method
- TPG-A – Analog control method
- TPG-S1 – Scania BWS control method
- TPG-S2 – Scania BCI control method
- TPG-D – Mercedes control method
- TPG-M – MAN control method
- TPG-V1 – Volvo FM/FH control method
- TPG-V2 – Volvo FE/FL control method
- FAW – FAW control method
- SLAVE – Second Sentry device

(See section 6.11.2 for engine configuration).

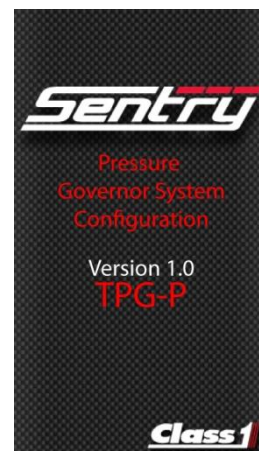
After the initialization the SENTRY begins normal operation.



 607 NW 27th Ave Ocala, FL 34475 Ph: 352-629-5020 or 1-800-533-3569 Fax: 352-629-2902 or 1-800-520-3473	TECHNICAL DATA SHEET			PAGE	10 OF 36	
	PRODUCT GROUP	THROTTLE CONTROL	P/N	3045-101-00-CL1, 3045-102-00-CL1	DATE	11/26/2019
	PRODUCT	SENTRY PRESSURE GOVERNOR			REV	1.14
					BY	IMC

4.2. Operating mode selection

The SENTRY has three operating modes: **throttle mode** (RPM), **pressure mode** (PSI) and **hi-idle mode** (HIDLE)



Press the **MODE** button to select an operating mode. An operating mode will only be activated if the required interlock(s) are in place (see section 4.3).

There is no variation in engine RPM or pump pressure when changing between **throttle mode** and **pressure mode**.



Pressure mode is the desired operating mode because it offers protection from pressure changes that could injure personnel.

4.2.1. Throttle mode

Throttle mode (RPM) maintains a set engine RPM and will not deviate until the operator changes the RPM with the control switches on the SENTRY. (Proper interlocking is required for normal operation – refer to Required Interlocking section 4.3)

Throttle mode is typically used when...

- priming the pump
- the water supply pressure stability is questionable
- connected to a stand pipe
- acting as a relay pumper



Press the **MODE** button to select **throttle mode**. The RPM mode indicator LED will illuminate blue.



Press a **PRESET** button to set the engine speed to the configured preset RPM - as long as the pump pressure is less than 10 PSI (see section 4.4). Configure the **throttle mode** presets through the USER Menu (see section 6.5.2 and 6.5.4)



Press the **INCREASE** or **DECREASE** buttons to adjust the pressure in either direction. (see section 3.4.5 and 3.4.6)



Press the **IDLE** button at any time to set the SENTRY back to standby. Both mode indicator LEDs will turn off when the engine speed reaches idle (see section 4.5).

Attention Ford F-Series Customers

While pumping or operating in split shaft/PTO mode, do not press the accelerator pedal or brake pedal. If the accelerator pedal or brake pedal is pressed while in split shaft/PTO mode, the engine will return to curb idle and control of the remote throttle or governor will be lost. This will cause the pump to be reduced to idle and water pressure will be reduced.

For complete details please reference service bulletin SB-143 at www.haleproducts.com or see last page

Additionally, the following baseline settings have been tested to work well on the Ford analog application:

Control Method: ANLG Idle Speed: 750 Max. Speed: 2500 RPM Gain: 550 RPM Gain Integrator 0.05V

These are general guidelines and may vary per vehicle and application.

 607 NW 27th Ave Ocala, FL 34475 Ph: 352-629-5020 or 1-800-533-3569 Fax: 352-629-2902 or 1-800-520-3473	TECHNICAL DATA SHEET			PAGE	11 OF 36
				DATE	11/26/2019
PRODUCT GROUP	THROTTLE CONTROL	P/N	3045-101-00-CL1, 3045-102-00-CL1	REV	1.14
PRODUCT	SENTRY PRESSURE GOVERNOR			BY	IMC

4.2.2. Pressure mode

Pressure mode maintains a set pump pressure by monitoring the discharge pressure transducer and modifying the pump speed by adjusting the engine RPM. The operator can modify the set pump pressure with the control switches on the SENTRY. (*Proper interlocking is required for normal operation – refer to Required Interlocking section 4.3*)



Pressure mode affords the most safety to the operator by not allowing potentially hazardous pressure spikes. The SENTRY will maintain the set pump pressure even when discharge lines are actively opened and closed as long as the water supply is sufficient. The SENTRY will automatically increase engine speed when pump pressure has decreased due to discharge lines being opened. The increase in engine speed will return the pump pressure to the desired set pressure (and vice-versa when discharge lines are closed).



Press the **MODE** button to select **pressure mode**. The PSI mode indicator LED will illuminate yellow. It may be necessary to press the **MODE** switch twice depending on the configured first mode (see section 6.9.1).



Press a **PRESET** button to set the pump pressure to the configured preset. The SENTRY will adjust the engine RPM to maintain the preset pressure value (see section 4.4). Configure the **pressure mode** preset through the Setup Menu (see section 6.5.3 and 6.5.5).



Press the **INCREASE** or **DECREASE** buttons to adjust the pressure in either direction. (see section 3.4.5 and 3.4.6)



Press the **IDLE** switch at any time to set the SENTRY back to standby. Both mode indicator LEDs will turn off when the engine speed reaches idle (see section 4.5).

 607 NW 27th Ave Ocala, FL 34475 Ph: 352-629-5020 or 1-800-533-3569 Fax: 352-629-2902 or 1-800-520-3473	TECHNICAL DATA SHEET			PAGE	12 OF 36
				DATE	11/26/2019
PRODUCT GROUP	THROTTLE CONTROL	P/N	3045-101-00-CL1, 3045-102-00-CL1	REV	1.14
PRODUCT	SENTRY PRESSURE GOVERNOR			BY	IMC

4.2.3. High Idle mode



High Idle mode maintains a set engine RPM and will not deviate until the operator loses the High Idle Interlock, Presses Idle on the SENTRY. *(Proper interlocking is required for normal operation – High Idle mode requires that only the Throttle Ready and High Idle interlocks are active.)*



Press the **MODE** button to select **throttle mode** and leave High Idle mode. The RPM mode indicator LED will illuminate blue.



Press a **PRESET** button to set the pump pressure to the configured preset. The SENTRY will adjust the engine RPM to maintain the preset pressure value (see section 4.4). Configure the **pressure mode** preset through the Setup Menu (see section 6.5.3 and 6.5.5).



Press the **INCREASE** or **DECREASE** buttons to adjust the pressure in either direction. (see section 3.4.5 and 3.4.6)



Press the **IDLE** button at any time to set the SENTRY back to standby. Both mode indicator LEDs will turn off when the engine speed reaches idle (see section 4.5).

 607 NW 27th Ave Ocala, FL 34475 Ph: 352-629-5020 or 1-800-533-3569 Fax: 352-629-2902 or 1-800-520-3473	TECHNICAL DATA SHEET			PAGE	13 OF 36	
	PRODUCT GROUP	THROTTLE CONTROL	P/N	3045-101-00-CL1, 3045-102-00-CL1	DATE	11/26/2019
	PRODUCT	SENTRY PRESSURE GOVERNOR			REV	1.14
					BY	IMC

4.2.4. Pressure mode control parameters

There are three control parameters which can be modified to improve **pressure mode** performance: pressure sensitivity, pressure time-out, and pressure gain.

CONTROL PARAMETER	DESCRIPTION	DEFAULT	SECTION
Pressure sensitivity	Controls how much difference between the target pressure and actual pressure that is allowed before the SENTRY actively adjusts the engine speed to bring the discharge pressure back to the target pressure.	6 PSI	6.8.1
Pressure time-out	The engine speed will be commanded to the idle RPM when the discharge pressure drops below 30 PSI (and only after the discharge pressure had been above 50 PSI) for the number of seconds configured. The alarm will sound and the OPERATOR CMD warning will be shown in the display window (see section 5).	3 Seconds	6.8.7
Pressure gain	The pressure change requested with each Twister control click in the INCREASE or DECREASE direction.	3 PSI	6.8.8

4.3. Required interlocking

The SENTRY requires interlocks before engine control operations are permitted. The SENTRY provides two interlock inputs that allow easy separation of pumping operations and throttle/high idle operations through two inputs dedicated as system interlocks: *THROTTLE READY* (pin 2 of connector C) and *PUMP ENGAGED* (pin 4 of connector D). These interlock inputs are activated when system power is applied (positive polarity).



The OEM is responsible for creating safe and effective interlocking routines.

The SENTRY uses green icons to indicate the status of the interlocks.

THROTTLE READY interlock



Apply system power to pin 2 of connector C (through OEM interlocking).
THROTTLE READY icon illuminates green.

The SENTRY will operate in **throttle mode** (RPM) only.

PUMP ENGAGED interlock



Apply system power to pin 4 of connector D (through OEM interlocking).
PUMP ENGAGED icon illuminates green.

The SENTRY will not operate in any mode until the THROTTLE READY interlock is also applied.

OKAY TO PUMP



When THROTTLE READY and PUMP ENGAGED interlocks are applied the OKAY TO PUMP icon illuminates green.

The SENTRY will operate in **throttle mode** (RPM) or **pressure mode** (PSI).

4.4. PRESET button operation



The **PRESET** buttons bring the discharge pressure (or engine RPM, in throttle mode) to the configured preset point (see section 6.5.2 to 6.5.5).

 607 NW 27th Ave Ocala, FL 34475 Ph: 352-629-5020 or 1-800-533-3569 Fax: 352-629-2902 or 1-800-520-3473	TECHNICAL DATA SHEET			PAGE	14 OF 36	
	PRODUCT GROUP	THROTTLE CONTROL	P/N	3045-101-00-CL1, 3045-102-00-CL1	DATE	11/26/2019
	PRODUCT	SENTRY PRESSURE GOVERNOR			REV	1.14
					BY	IMC

Using a **PRESET** button is a method of smoothly and expeditiously attaining water pressure and flow, but it is not intended to be the initial attack pressure. Attack pressures and flows should be determined by the actual fire status and manually achieved for best operation.

PRESET is an operational convenience and needs to be considered as a fixed point (higher or lower than the current point) that can be achieved with a single button press.

Note: Initiating pumping operations is simplified by bringing the pump to a preset pressure with a single button press. Consequently, securing or regaining control operations can be aided by returning to this fixed pressure point with a single button press.

4.5. IDLE button operation



Press and hold the **IDLE** button for **one second** to release engine RPM control back to the engine ECU. The engine RPM will promptly go to its configured curb idle (see section 6.9.3).

Note: In view of the fact that driveline stress can be induced by quick changes in engine speed, depending on rpm and torque load, the engine speed is ramped to idle over a short duration to minimize the effect of driveline kick.

 607 NW 27th Ave Ocala, FL 34475 Ph: 352-629-5020 or 1-800-533-3569 Fax: 352-629-2902 or 1-800-520-3473	TECHNICAL DATA SHEET			PAGE	15 OF 36
				DATE	11/26/2019
PRODUCT GROUP	THROTTLE CONTROL	P/N	3045-101-00-CL1, 3045-102-00-CL1	REV	1.14
PRODUCT	SENTRY PRESSURE GOVERNOR			BY	IMC

5. Warning and Error messages



The Sentry displays warning and error messages on a red bar in front of the secondary information displays and the “more information” and “clear message” icons appear below the soft buttons.



More information

Press the soft button above this icon to learn more about the current warning or error message (first level information).



Clear message

Press the soft button above this icon to clear the warning message from the screen.

5.1. First level message information (operator)

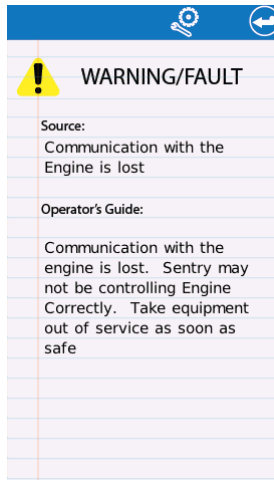

The first level message information screen is designed for the operator and will give basic information about the current warning/error as well as simple instructions on what should be accomplished next.



Press the “technician information” soft button to display the second level message information which gives a technician detailed information about the warning/error message that is currently displayed.



Press the “return” soft button to exit the first level message information and return to the standard operating screen.

 607 NW 27th Ave Ocala, FL 34475 Ph: 352-629-5020 or 1-800-533-3569 Fax: 352-629-2902 or 1-800-520-3473	TECHNICAL DATA SHEET			PAGE	16 OF 36
				DATE	11/26/2019
PRODUCT GROUP	THROTTLE CONTROL	P/N	3045-101-00-CL1, 3045-102-00-CL1	REV	1.14
PRODUCT	SENTRY PRESSURE GOVERNOR			BY	IMC

5.2. Second level message information (technician)

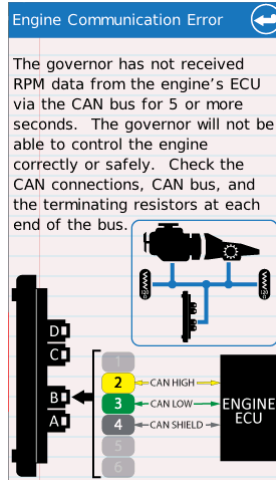

The second level message information screen is designed for the technician and will give more information about the current warning/error as well as simple instructions on what should be evaluated in order to correct the warning/error.



Press the "return" soft button to exit the second level message information and return to the standard operating screen.

5.3. List of warning/error messages

MESSAGE	DESCRIPTION	SENTRY RESPONSE	OPERATOR ACTION
Communication with the engine is lost	The SENTRY is not receiving CAN communication for engine RPM.	<i>No change in operation.</i>	<i>Operator should cancel SENTRY operation and have engine to SENTRY communication verified.</i>
Throttle Interlock Is Not Enabled	The SENTRY's throttle interlock is not active when the MODE button was pressed.	<i>No change in operation.</i>	<i>Operator should activate OEM interlocking that enables the SENTRY's throttle interlock.</i>
Pump Engaged Interlock Not Enabled	The SENTRY's pump engaged interlock is not active when the MODE button was pressed.	<i>No change in operation.</i>	<i>Operator should activate OEM interlocking that enables the SENTRY's pump engaged interlock.</i>
Low Battery Voltage Fault	The Sentry's supply voltage is less than or equal to 11.9VDC (12 volt system) or 23.8VDC (24 volt system). The voltage set point is adjustable in the factory menu.	<i>No change in operation.</i>	<i>Operator should determine the cause of the low voltage condition.</i>
Low Battery Voltage Warning	The Sentry's supply voltage is less than or equal to 12.4VDC (12 volt system) or 24.8VDC (24 volt system). The voltage set point is adjustable in the factory menu.	<i>No change in operation.</i>	<i>Operator should determine the cause of the low voltage condition.</i>
Low Oil Pressure Fault	The Sentry has received low oil pressure diagnostic message (bus warnings) or the oil pressure is less than the configured limit (user warnings).	<i>No change in operation.</i>	<i>Operator should cancel SENTRY operation and determine the cause of the low oil pressure fault.</i>
Low Oil Pressure Warning	The Sentry has received low oil pressure diagnostic message (bus warnings) or the oil pressure is less than the configured limit (user warnings).	<i>No change in operation.</i>	<i>Operator should cancel SENTRY operation and determine the cause of the low oil pressure warning.</i>

 <p>607 NW 27th Ave Ocala, FL 34475 Ph: 352-629-5020 or 1-800-533-3569 Fax: 352-629-2902 or 1-800-520-3473</p>	TECHNICAL DATA SHEET			PAGE	17 OF 36	
				DATE	11/26/2019	
	PRODUCT GROUP	THROTTLE CONTROL	P/N	3045-101-00-CL1, 3045-102-00-CL1	REV	1.14
	PRODUCT	SENTRY PRESSURE GOVERNOR			BY	IMC

MESSAGE	DESCRIPTION	SENTRY RESPONSE	OPERATOR ACTION
Coolant High Temperature Fault	The Sentry has received high coolant temperature diagnostic message (bus warnings) or the coolant temperature is greater than the configured limit (user warnings).	<i>No change in operation.</i>	<i>Operator should cancel SENTRY operation and determine the cause of the high coolant temperature fault.</i>
Coolant High Temperature Warning	The Sentry has received high coolant temperature diagnostic message (bus warnings) or the coolant temperature is greater than the configured limit (user warnings).	<i>No change in operation.</i>	<i>Operator should cancel SENTRY operation and determine the cause of the high coolant temperature warning.</i>
Intake Sensor Fault	Signal voltage from the intake pressure sensor is less than +0.30VDC or greater than +4.90VDC.	<i>No change in operation.</i>	<i>Operator may continue to use SENTRY in PRESSURE or THROTTLE mode. Operator should have the intake pressure sensor and associated wiring verified.</i>
Discharge Sensor Fault	Signal voltage from the discharge pressure sensor is less than +0.30VDC or greater than +4.90VDC.	<i>SENTRY switches to THROTTLE mode operation.</i>	<i>Operator may continue to use SENTRY in THROTTLE mode. Operator should have the discharge pressure sensor and associated wiring verified.</i>
Check Engine Warning	The engine control unit is reporting a check engine light.	<i>No change in operation.</i>	<i>Operator may view the specific warning and determine if SENTRY operation should be discontinued and the engine turned OFF.</i>
Stop Engine Fault	The engine control unit is reporting a stop engine light.	<i>No change in operation.</i>	<i>Operator may view the specific fault and then discontinue SENTRY operation and turn off the engine.</i>
Intake Pressure not in Range to be Zeroed	Signal voltage from the intake pressure sensor is less than +0.45VDC or greater than +0.80VDC.	<i>SENTRY will not allow the intake pressure to be calibrated to zero.</i>	<i>Operator should verify that the intake pressure is actually zero.</i>
Discharge Pressure not in Range to be Zeroed	Signal voltage from the discharge pressure sensor is less than +0.45VDC or greater than +0.80VDC.	<i>SENTRY will not allow the discharge pressure to be calibrated to zero.</i>	<i>Operator should verify that the discharge pressure is actually zero.</i>
Water Supply Insufficient	Pump discharge pressure decreased 5 or more PSI as engine speed was increased 120 or more RPM (while in pressure mode).	<i>SENTRY reduces engine speed to 1100 RPM and attempts to increase discharge pressure by ramping engine RPM.</i>	<i>Operator should verify water supply or change to THROTTLE mode.</i>
Discharge Pressure Less than 30 PSI	Pump intake pressure loss. Discharge pressure dropped below 30 PSI.	<i>SENTRY maintains engine speed at 1100 RPM for the configured pressure time-out (6.8.7).</i>	<i>Operator should verify water supply or change to THROTTLE mode.</i>

 607 NW 27th Ave Ocala, FL 34475 Ph: 352-629-5020 or 1-800-533-3569 Fax: 352-629-2902 or 1-800-520-3473	TECHNICAL DATA SHEET			PAGE	18 OF 36
	PRODUCT GROUP	THROTTLE CONTROL	P/N	3045-101-00-CL1, 3045-102-00-CL1	DATE
PRODUCT	SENTRY PRESSURE GOVERNOR			REV	1.14
				BY	IMC

MESSAGE	DESCRIPTION	SENTRY RESPONSE	OPERATOR ACTION
CRITICAL: Sentry In Standby. Check Water Source	Pump discharge pressure has been less than 30 PSI for longer than the configured pressure time-out .	<i>SENTRY reduces engine speed to the idle RPM and returns to IDLE mode operation.</i>	<i>Operator should verify water supply and then re-enable PRESSURE mode operation.</i>
Unable to maintain discharge pressure	The SENTRY has increased the engine speed more than 300 RPM above the stasis RPM.	<i>SENTRY maintains the engine speed at the stasis RPM + 300.</i>	<i>Operator should verify water supply to determine why the desired discharge pressure cannot be maintained.</i>
Discharge Pressure Has Increased More Than 50 PSI Since Setting RPMs	The SENTRY is in THROTTLE mode and the discharge pressure has increased more than 50 PSI over the previous stasis pressure.	<i>SENTRY maintains THROTTLE mode operation but limits the engine RPM to maintain no more than a 50 PSI differential over the pressure detected when the operator set the desired engine RPM.</i>	<i>No operator action required. Operator may continue to use SENTRY in THROTTLE mode.</i>
5 volt reference error	The SENTRY is not detecting the 5 volt supply voltage required for analog control (pin 1, connector C).	<i>The SENTRY will not be able to create the variable voltage required for analog control mode.</i>	<i>Operator should have the SENTRY wiring confirmed.</i>
Water Pressure > 10 PSI and Preset Inhibit Enabled	The SENTRY has been configured for RPM Preset inhibit. The operator has pressed the RPM preset button when 10 or more PSI of discharge pressure is detected.	<i>The SENTRY will not increase engine speed to the preset RPM.</i>	<i>Operator should determine why discharge pressure is detected on the discharge side of the pump.</i>
Preset Is Not Permitted With Discharge PSI Less Than 30	The SENTRY detects less than 30 PSI of discharge pressure.	<i>The Sentry will not allow preset operation</i>	<i>The operator should manually adjust discharge pressure to above 30 PSI and then use the desired preset.</i>
Intake pressure is too low for POSITIVE pressure operation	The SENTRY had determined that the pump was operating with positive intake pressure and currently the intake pressure is below the configured threshold.	<i>No change in operation.</i>	<i>Operator should verify the intake pressure to ensure proper pumping operation.</i>

 607 NW 27th Ave Ocala, FL 34475 Ph: 352-629-5020 or 1-800-533-3569 Fax: 352-629-2902 or 1-800-520-3473	TECHNICAL DATA SHEET			PAGE	19 OF 36	
	PRODUCT GROUP	THROTTLE CONTROL	P/N	3045-101-00-CL1, 3045-102-00-CL1	DATE	11/26/2019
	PRODUCT	SENTRY PRESSURE GOVERNOR			REV	1.14
					BY	IMC

5.3.1. Intake or Discharge Sensor Fault

The **Intake** and **Discharge Sensor Fault** warning messages indicate that the associated pressure sensor signal voltage is out of range (<0.30 VDC or >4.90 VDC). When this occurs the SENTRY does not have valid pressure data and responds by switching operation to THROTTLE mode (where pressure data is not required). There are typically four reasons the pressure sensor voltage is out of range:

- The pressure sensor is damaged.
- The pressure sensor signal wire is broken.
- The pressure sensor ground wire is broken (signal voltage will be at 5.00 VDC).
- The pressure sensor supply voltage wire is broken (signal voltage will be at 0.00 VDC).

5.3.2. Water Supply Insufficient, Discharge Pressure Less Than 30 Psi, and Critical: Sentry In Stand By. Check Water Source

Water Supply Insufficient, Discharge Pressure Less Than 30 Psi, and Critical: Sentry In Stand By. Check Water Source work together and in sequence when the discharge water pressure cannot be maintained due to cavitation or inadequate water supply.

- The **Water Supply Insufficient** message appears first after the SENTRY has attempted to maintain discharge pressure by increasing the engine RPM. Failing to maintain the discharge pressure, the SENTRY drops the engine speed to 1100 RPM and begins increasing the RPM as part of the Supply Intake Protection (SIP) routine.
- The **Discharge Pressure Less Than 30 Psi** message appears after the Supply Intake Protection (SIP) routine has failed and the discharge pressure has dropped below 30 PSI. The SENTRY maintains the engine speed at 1100 RPM for the time period defined by the pressure time-out variable (3 seconds default, see section 6.8.7).
- The **Critical: Sentry In Stand By. Check Water Source** message appears after the SENTRY has switched to STANDBY mode (IDLE). This message informs the operator that the SENTRY could not maintain a discharge pressure of 30 PSI or more. The water supply must be verified.

5.3.3. Unable To Maintain Discharge Pressure

The SENTRY in PRESSURE mode maintains the operator set discharge pressure by adjusting the engine RPM. The SENTRY increases the engine RPM to return to the operator's set discharge pressure when a pressure drop is detected. The SENTRY maintains the *Limit RPM* and displays the warning message when the SENTRY cannot fully regain the operator's set discharge pressure. The Range can be adjusted through the Pressure Lag menu item.

$$\text{Limit RPM} = \text{RPM}_{\text{STASIS}} + \text{RPM}_{\text{RANGE}}$$

$\text{RPM}_{\text{STASIS}}$ = Engine RPM where operator's pressure was last stable.

$\text{RPM}_{\text{RANGE}}$ = Engine RPM increase range (300 RPM if $\text{RPM}_{\text{STASIS}} < 1500$, 200 RPM if $\text{RPM}_{\text{STASIS}} > 1500$)

For example: The SENTRY is maintaining the operator's set discharge pressure of 100 PSI at 1100 RPM. The pressure drops to 90 PSI and the SENTRY compensates by increasing the engine RPM. The SENTRY continues increasing engine speed until 1400 RPM is reached but the discharge pressure has only increased to 92 PSI so the SENTRY maintains 1400 RPM and displays the warning message.

5.3.4. Discharge Pressure Has Increased More Than 50 Psi Since Setting Rpm's

The SENTRY in THROTTLE mode maintains the operator set engine RPM. But the SENTRY will limit the discharge pressure if the pressure recorded when the RPM was last set has increased more than 50 PSI. The SENTRY will reduce the engine RPM to maintain the pressure increase to no more than a 50 PSI differential and display the warning message. The SENTRY does not attempt to regulate pressure while in THROTTLE mode, but it will attempt to limit a pressure increase to a maximum of 50 PSI over the pressure detected when the operator set the desired engine RPM.

 607 NW 27th Ave Ocala, FL 34475 Ph: 352-629-5020 or 1-800-533-3569 Fax: 352-629-2902 or 1-800-520-3473	TECHNICAL DATA SHEET			PAGE	20 OF 36
				DATE	11/26/2019
	PRODUCT GROUP	THROTTLE CONTROL	P/N	3045-101-00-CL1, 3045-102-00-CL1	
	PRODUCT	SENTRY PRESSURE GOVERNOR			REV
				BY	IMC

For example: The SENTRY is maintaining the operator's desired engine speed of 1100 RPM (at a discharge pressure of 100 PSI). The discharge pressure increases to 160 PSI (e.g. a discharge line was closed) and the SENTRY decreases the engine RPM until the discharge pressure is reduced to 150 PSI (50 PSI differential).

5.3.5. Communication with engine is lost

The SENTRY receives engine RPM data via CAN communication (PGN 61444, SPN 190). The SENTRY displays this warning message after not receiving the RPM data for 4 or more seconds.

Note: If the SENTRY is configured for a CAN control and this warning message is active due to a CAN bus problem, then the control of the engine RPM cannot be certain since the engine ECU may not receive engine speed request data from the SENTRY.

 607 NW 27th Ave Ocala, FL 34475 Ph: 352-629-5020 or 1-800-533-3569 Fax: 352-629-2902 or 1-800-520-3473	TECHNICAL DATA SHEET			PAGE	21 OF 36	
	PRODUCT GROUP	THROTTLE CONTROL	P/N	3045-101-00-CL1, 3045-102-00-CL1	DATE	11/26/2019
	PRODUCT	SENTRY PRESSURE GOVERNOR			REV	1.14
					BY	IMC

6. Sentry Setup Menus

6.1. Engine compatibility

The factory default settings of the SENTRY make it “out of the box” ready to operate a Cummins engine programmed with the Emergency Vehicle Calibration. Typically, for the default configuration no values will require modification, other than changing the desired engine rpm, high-idle rpm and pump pressure preset values.

The governor is capable of controlling any engine that allows J1939 PGN0 (Torque Speed Control) messages from a unique source address. These engines include various Detroit Diesel DDEC engines, Mercedes Benz (MBE) engines, Volvo, and others. Programming of the source address or other parameters on the engine ECM may be required. The Scania and MAN engines allow control by proprietary J1939 messages and are supported by the SENTRY. In cases where an engine does not support data link control, the SENTRY can be configured to control the engine with an analog signal coupled to the engine remote PTO throttle input. Contact Class 1 for a complete engine compatibility list.

6.2. Enter the setup menu



The MENU button is only available when the Sentry is not in an active operating mode (pressure, RPM). Access the menu by pressing the “soft button” associated with the menu icon shown on the Sentry’s display.

The INFO and USER menus are standard and do not require a password. A password must be entered to access the COMMAND, OEM1, OEM2, OEM3, FACTORY 1 and FACTORY 2 menu levels.

6.2.1. Menu soft buttons

The icons near each of the soft buttons indicate their operation.



The UP ARROW button moves the menu highlight bar (yellow) to the previous menu item.



The DOWN ARROW button moves the menu highlight bar (yellow) to the next menu item.



The INCREASE button changes the currently selected menu item’s to the next option.



The DECREASE button changes the currently selected menu item’s to the next option.



The EXIT/CANCEL button exits the menu and returns to the main screen.



The UNLOCK button opens the password entry screen. Passwords are required to access menu items beyond the INFO and USER menus.



The NEXT MENU button cycles to the next available menu screen. Some menu screens require entering a password.



The SAVE button saves any changes to the menu(s).

 607 NW 27th Ave Ocala, FL 34475 Ph: 352-629-5020 or 1-800-533-3569 Fax: 352-629-2902 or 1-800-520-3473	TECHNICAL DATA SHEET			PAGE	22 OF 36	
	PRODUCT GROUP	THROTTLE CONTROL	P/N	3045-101-00-CL1, 3045-102-00-CL1	DATE	11/26/2019
	PRODUCT	SENTRY PRESSURE GOVERNOR			REV	1.14
					BY	IMC

6.3. Password Entry Screen



The Password Entry Screen allows for access to the various menus along with special functions.

- COMMAND MENU - 0311
- OEM 1 MENU - 1560
- OEM 2 MENU - 9769
- OEM 3 MENU - 3317
- OEM 4 MENU - 1505
- FACTORY 1 MENU - 6679
- FACTORY 2 MENU - 7081
- USB BOOTLOADER - 4235
- RESET PUMP HOURS - 0414
- USB SAVE MENU ITEMS - 5224
- USB LOAD MENU ITEMS - 0592

6.3.1. Reset the Pump Hours

Enter the Password Entry screen and enter 0414 then press the SAVE button. The display will prompt you to verify that you want to reset the pump hours. Press the green accept button to reset or the red cancel button to not reset. Once back to the INFO menu you must press the SAVE button to save the reset operation and exit the menu.

6.3.2. USB Bootloader

Enter the Password Entry screen and enter 4235 then press the SAVE button. The display will prompt you to verify that you want to reboot and load new firmware. Make sure you have a USB thumb drive with your new Sentry firmware plugged into Port A. Press the green accept button to reset or the red cancel button to not reboot. Follow the on screen instructions and select the desired Sentry firmware. The firmware will need to be on the root directory of the USB thumb drive, it cannot be in a folder on the drive.

6.3.3. Save Menu Items to a USB thumb drive

Enter the Password Entry screen and enter 5224 then press the SAVE button. The display will prompt you to verify that you want to save the menu parameters to a USB thumb drive. Make sure you have a USB thumb drive plugged into Port A. Press the green accept button to save the parameters or the red cancel button to not save the parameters. Once saved you can rename your file using your PC but do not edit the contents as a corrupt file will be unreadable on a SENTRY.

6.3.4. Load Menu Items from a USB thumb drive

Enter the Password Entry screen and enter 0592 then press the SAVE button. The display will prompt you to verify that you want to load new menu parameters from a USB thumb drive. Make sure you have a USB thumb drive plugged into Port A. Press the green accept button to load a list of files on the drive to the SENTRY or press the red cancel button to not load the list of files. On this screen use the UP and DOWN arrows to navigate the list which may be several pages. You can press the red cancel button to leave the list and return to the menu without loading new menu parameters. You can press the SAVE button on any item in the list and you will be prompted to verify that you want to try to load the file and present the file's name to you. Press the green RETURN button to try to read the file or press the red cancel button to return to the list of files.

****NOTE:** If the firmware versions of the Sentry on the USB does not match the version on the current display it will fail to load. If the file has been corrupted, it will fail to load. Please only rename the file and do not edit to the contents. Opening the file in a text editor appends data on the end of the file that will make it unreadable to a SENTRY**

 607 NW 27th Ave Ocala, FL 34475 Ph: 352-629-5020 or 1-800-533-3569 Fax: 352-629-2902 or 1-800-520-3473	TECHNICAL DATA SHEET			PAGE	23 OF 36	
	PRODUCT GROUP	THROTTLE CONTROL	P/N	3045-101-00-CL1, 3045-102-00-CL1	DATE	11/26/2019
	PRODUCT	SENTRY PRESSURE GOVERNOR			REV	1.14
					BY	IMC

6.4. INFO menu

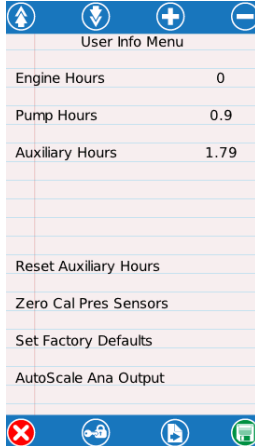

User Info Menu	
Engine Hours	0
Pump Hours	0.9
Auxiliary Hours	1.79
Reset Auxiliary Hours	
Zero Cal Pres Sensors	
Set Factory Defaults	
AutoScale Ana Output	

The User Info Menu allows viewing of the Engine Hours, Pump Hours, and Auxiliary Hours.

DISPLAY ITEM	FORMAT	SOURCE
Engine hours	XX.XX h	SAE J1939 CAN message – PGN 65253
Pump hours	XX.XX h	Internal timer, running with pump engaged interlock
Auxiliary hours	XX.XX h	Internal timer, always running

This menu also allows resetting of the auxiliary hours and zero calibrating the pressure sensors, setting the factory defaults, and auto scaling the analog output (for analog control method).

Use the soft buttons to navigate and execute options.

6.4.1. Reset the Auxiliary Hours

Enter the INFO menu and select “Reset Auxiliary Hours” then press the SAVE button. The display will prompt you to verify that you want to reset the auxiliary hours. Press the green accept button to reset or the red cancel button to not reset. Once back to the INFO menu you must press the SAVE button to save the reset operation and exit the menu.

6.4.2. Zero Calibrate the pressure sensors

Enter the INFO menu and select “Zero Cal Pres Sensors” then press the SAVE button. The display will prompt you to verify that you want to zero the pressure sensors. Press the green ACCEPT button to reset or the red CANCEL button to not reset. Once back to the INFO menu you must press the SAVE button to save the zero calibration operation and exit the menu.

6.4.3. Set Factory Defaults

Enter the INFO menu and select “Set Factory Defaults” then press the SAVE button. The display will prompt you to verify that you want to set the factory defaults. Press the green accept button to reset or the red cancel button to not reset. Once back to the INFO menu you must press the SAVE button to save the factory default operation and exit the menu.

6.4.4. Autoscale Analog Output

A SENTRY set to Analog control mode (see section 6.11.2) may use the Auto Scale configure method to automatically set the IDLE voltage (see sections 6.4.4 and 6.12.4) and GAIN setting (6.9.5).

The engine must be running and the interlocks (as defined in section 4.3) must be enabled when running the Auto Scale mode. Enter the INFO menu and select “AutoScale Analog Output” then press the SAVE button. The display will prompt you to verify that you want to set the Auto Scale the analog output. Press the green accept button to reset or the red cancel button to not reset. If the engine control method is not set for “analog” a warning will be shown and Auto Scale will not be attempted. Once back to the INFO menu you must press the SAVE button to save the Auto Scale operation and exit the menu.

 <p>607 NW 27th Ave Ocala, FL 34475 Ph: 352-629-5020 or 1-800-533-3569 Fax: 352-629-2902 or 1-800-520-3473</p>	TECHNICAL DATA SHEET			PAGE	24 OF 36	
				DATE	11/26/2019	
	PRODUCT GROUP	THROTTLE CONTROL	P/N	3045-101-00-CL1, 3045-102-00-CL1	REV	1.14
	PRODUCT	SENTRY PRESSURE GOVERNOR			BY	IMC

Defaults:					
Unit of measure	= PSI, °F	Oil pressure critical	= 20 PSI	Inhibit Presets by Pres.	= YES
Preset RPM 1	= 1000	Warn. Voltage 12V	= 12.4	Voltage Adjust	= 0 v
Preset pressure 1	= 100	Crit. Voltage 12V	= 11.9	Max Rate of RPM Change	= 200
Preset RPM 2	= 1000	Warn. Voltage 24V	= 24.8	RPM Gain Integrator	= 0.5
Preset pressure 2	= 100	Crit. Voltage 24V	= 23.8	Max Rate of PSI Change	= 200
Brightness day	= 70	Pressure sensitivity	= 5 PSI	PSI Gain Integrator	= 0.5
Brightness night	= 50	Intake pressure offset	= 0	System voltage	= 12 volts
Round pressure	= YES	Discharge pressure offset	= 0	Engine control method	= unknown
Day/night mode	= DAY	Intake sensor range	= 300 PSI	Source ID	= 7
Twister rotation increase	= CW	Discharge sensor range	= 300 PSI	Display Orientation	= Horz
Display Fuel Economy	= YES	Intake Threshold, PSI	= 5 PSI	Slave Orientation	= Horz
Display Trans. Temp	= YES	Pressure time out	= 8 seconds	Language	= English
Display Oil Pressure	= YES	Pressure mode gain	= 1 PSI	Baud Rate	= 250K
Display Disch. Pressure	= YES	Pressure lag	= 0 PSI	Ok to Pump Mode	= Normal
Display Intk. Pressure	= YES	First mode	= Pressure	Twister Enable	= DISABLED
Iconography	= DEFAULT	Inhibit RPM presets	= NO	Alert tone	= ENABLE
High Idle Preset	= 1000	Idle speed	= 700 RPM	Volts Yellow Warn.	= DISABLE
Warning source	= CAN Bus	Maximum speed	= 2400 RPM	Control auto mode	= Disabled
Coolant temp warning	= 180 °F	RPM mode gain	= 750 RPM/v	Idle voltage	= 0.5 volts
Coolant temp critical	=230 °F	Dither enable	= NO	BCM1 version	= 1
Oil pressure warning	= 40 PSI	Max Pressure	= 500 PSI	Scania mode	= NORMAL
				SPN 696	= 3
				Alarms Behind OEM Intlk	= DISABLED

USER
 COMMAND
 OEM 1
 OEM 2
 OEM 3
 OEM 4
 FACTORY 1
 FACTORY 2

6.5. USER menu



User Menu	
Units of meas.	PSI/Deg F
Preset 1, RPM	1000
Preset 1, PSI	100
Preset 2, RPM	1000
Preset 2, PSI	100
Brightness (day)	70
Brightness (night)	50
Round to 5 PSI	Yes
Display Mode	Day

The User Menu allows configuration of standard user modifiable items.

- Unit of measure
- Preset RPM 1
- Preset pressure 1
- Preset RPM 2
- Preset pressure 2
- Brightness, day
- Brightness, night
- Round pressure
- Display mode

Use the soft buttons to navigate and modify options.

 607 NW 27th Ave Ocala, FL 34475 Ph: 352-629-5020 or 1-800-533-3569 Fax: 352-629-2902 or 1-800-520-3473	TECHNICAL DATA SHEET			PAGE	25 OF 36	
	PRODUCT GROUP	THROTTLE CONTROL	P/N	3045-101-00-CL1, 3045-102-00-CL1	DATE	11/26/2019
	PRODUCT	SENTRY PRESSURE GOVERNOR			REV	1.14
					BY	IMC

6.5.1. Change the unit of measure

Enter the USER menu and select “Units of meas” then press the INCREASE or DECREASE buttons to change to the desired unit of measure (PSI/Deg F, kPa/Deg C, or Bar/Deg C). Press the SAVE button to save the USER menu items and exit the menu.

6.5.2. Change the Preset RPM 1

Enter the USER menu and select “Preset 1 (RPM)” then press the INCREASE or DECREASE buttons to change the preset RPM 1 to the desired value (900 to 1800 in 25 RPM steps). Press the SAVE button to save the USER menu items and exit the menu.

6.5.3. Change the Preset Pressure 1

Enter the USER menu and select “Preset 1 (PSI/kPa/BAR)” then press the INCREASE or DECREASE buttons to change the preset pressure 1 to the desired value (90 to 175 PSI, 621 to 1207 kPa, 6.21 to 12.07 Bar). Press the SAVE button to save the USER menu items and exit the menu.

6.5.4. Change the Preset RPM 2

Enter the USER menu and select “Preset 2 (RPM)” then press the INCREASE or DECREASE buttons to change the preset RPM 2 to the desired value (900 to 1800 in 25 RPM steps). Press the SAVE button to save the USER menu items and exit the menu.

6.5.5. Change the Preset Pressure 2

Enter the USER menu and select “Preset 2 (PSI/kPa/BAR)” then press the INCREASE or DECREASE buttons to change the preset pressure 2 to the desired value (90 to 175 PSI, 621 to 1207 kPa, 6.21 to 12.07 Bar). Press the SAVE button to save the USER menu items and exit the menu.

6.5.6. Change the Display Brightness (day mode)

Enter the USER menu and select “Brightness (day)” then press the INCREASE or DECREASE buttons to change the brightness to the desired value (1 to 100). Press the SAVE button to save the USER menu items and exit the menu.

6.5.7. Change the Display Brightness (night mode)

Enter the USER menu and select “Brightness (night)” then press the INCREASE or DECREASE buttons to change the brightness to the desired value (1 to 100). Press the SAVE button to save the USER menu items and exit the menu.

6.5.8. Round pressure

Enter the USER menu and select “Round to [5 PSI/34.5 kPa/0.345 Bar]” then press the INCREASE or DECREASE buttons to select YES or NO. Press the SAVE button to save the USER menu items and exit the menu.

6.5.9. Change the Display Mode (Day or Night)

Enter the USER menu and select “Display Mode” then press the INCREASE or DECREASE buttons to change the display mode to DAY or NIGHT. Press the SAVE button to save the USER menu items and exit the menu.

 607 NW 27th Ave Ocala, FL 34475 Ph: 352-629-5020 or 1-800-533-3569 Fax: 352-629-2902 or 1-800-520-3473	TECHNICAL DATA SHEET			PAGE	26 OF 36
				DATE	11/26/2019
PRODUCT GROUP	THROTTLE CONTROL	P/N	3045-101-00-CL1, 3045-102-00-CL1	REV	1.14
PRODUCT	SENTRY PRESSURE GOVERNOR			BY	IMC

6.6. Command menu

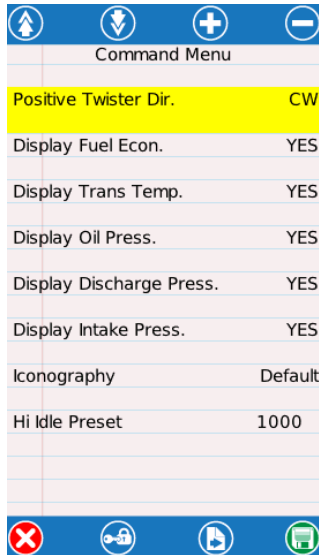

The Command Menu allows configuration of standard user modifiable items. The Command menu requires a password (0311).

- Positive Twister Direction
- Display Fuel Economy
- Display Transmission Temperature
- Display Oil Pressure
- Display Discharge Pressure
- Display Intake Pressure
- Iconography

Use the soft buttons to navigate and modify options.

6.6.1. Positive Twister Direction

This menu item allows configuration of the direction the Twister control knob must be turned for increasing RPM/Pressure. CW equals clockwise and CCW equals counter-clockwise.

6.6.2. Display Fuel Economy

This menu item allows the display window for the fuel economy to be seen or hidden. YES indicates the display will be shown, NO indicates it will not.

6.6.3. Display Transmission Temperature

This menu item allows the display window for the transmission temperature to be seen or hidden. YES indicates the display will be shown, NO indicates it will not.

6.6.4. Display Oil Pressure

This menu item allows the display window for the engine oil pressure to be seen or hidden. YES indicates the display will be shown, NO indicates it will not.

6.6.5. Display Discharge Pressure

This menu item allows the display window for the discharge pressure to be seen or hidden. YES indicates the display will be shown, NO indicates it will not.

6.6.6. Display Intake Pressure

This menu item allows the display window for the intake pressure to be seen or hidden. YES indicates the display will be shown, NO indicates it will not.

6.6.7. Iconography

This menu item allows the user to swap on screen icon between the Sentry's traditional icons and international FAMA icons. DEFAULT indicates traditional icons, INTERNATIONAL indicates FAMA icons.

 607 NW 27th Ave Ocala, FL 34475 Ph: 352-629-5020 or 1-800-533-3569 Fax: 352-629-2902 or 1-800-520-3473	TECHNICAL DATA SHEET			PAGE	27 OF 36	
	PRODUCT GROUP	THROTTLE CONTROL	P/N	3045-101-00-CL1, 3045-102-00-CL1	DATE	11/26/2019
	PRODUCT	SENTRY PRESSURE GOVERNOR			REV	1.14
					BY	IMC

6.6.8. High Idle Preset

This menu item allows the user to configure the RPM that entering High Idle mode would target. It is adjustable from 900 to 1800 in steps of 25.

6.7. OEM 1 menu

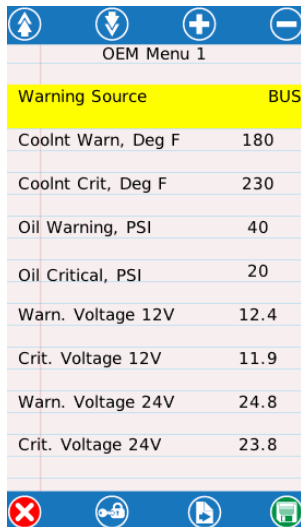

OEM Menu 1	
Warning Source	BUS
Coolnt Warn, Deg F	180
Coolnt Crit, Deg F	230
Oil Warning, PSI	40
Oil Critical, PSI	20
Warn. Voltage 12V	12.4
Crit. Voltage 12V	11.9
Warn. Voltage 24V	24.8
Crit. Voltage 24V	23.8

The OEM 1 Menu allows configuration of OEM modifiable items. The OEM 1 menu requires a password (1560).

- Warning source
- Coolant temperature warning (degrees)
- Coolant temperature critical (degrees)
- Oil pressure warning (pressure)
- Oil pressure critical (pressure)
- Warning Voltage 12v
- Critical Voltage 12v
- Warning Voltage 24v
- Critical Voltage 24v

Use the soft buttons to navigate and modify options.

6.7.1. Warning Source

This menu item configures the coolant temperature and oil pressure warnings to be determined by the CAN Bus or by user selected points. Enter the OEM 1 menu and select "Warning Source" then press the INCREASE or DECREASE buttons to change to the value (BUS or USER). Press the SAVE button to save the OEM 1 menu items and exit the menu.

6.7.2. Coolant Temperature Warning (USER)

This menu item configures the coolant temperature warning trip point. This value is only used if the Warning Source is set to "USER". Enter the OEM 1 menu and select "Cool Tmp Warn (Deg F/DegC)" then press the INCREASE or DECREASE buttons to change to the warning temperature trip point. Press the SAVE button to save the OEM 1 menu items and exit the menu.

6.7.3. Coolant Temperature Critical (USER)

This menu item configures the coolant temperature critical trip point. This value is only used if the Warning Source is set to "USER". Enter the OEM 1 menu and select "Cool Tmp Crit (Deg F/DegC)" then press the INCREASE or DECREASE buttons to change to the critical temperature trip point. Press the SAVE button to save the OEM 1 menu items and exit the menu.

6.7.4. Oil Pressure Warning (USER)

This menu item configures the oil pressure warning trip point. This value is only used if the Warning Source is set to "USER". Enter the OEM 1 menu and select "Oil Press Warn (PSI/kPa/Bar)" then press the INCREASE or DECREASE buttons to change to the warning pressure trip point. Press the SAVE button to save the OEM 1 menu items and exit the menu.

6.7.5. Oil Pressure Critical (USER)

This menu item configures the oil pressure critical trip point. This value is only used if the Warning Source is set to "USER". Enter the OEM 1 menu and select "Oil Press Crit (PSI/kPa/Bar)" then press the INCREASE or

 607 NW 27th Ave Ocala, FL 34475 Ph: 352-629-5020 or 1-800-533-3569 Fax: 352-629-2902 or 1-800-520-3473	TECHNICAL DATA SHEET			PAGE	28 OF 36
				DATE	11/26/2019
PRODUCT GROUP	THROTTLE CONTROL	P/N	3045-101-00-CL1, 3045-102-00-CL1	REV	1.14
PRODUCT	SENTRY PRESSURE GOVERNOR			BY	IMC

DECREASE buttons to change to the critical pressure trip point. Press the SAVE button to save the OEM 1 menu items and exit the menu.

6.7.6. **Warning Voltage 12V**

This menu item allows the warning voltage point to be adjusted to a user desired value within the range of 12.0V-13.0V for 12V systems (based on the selected battery voltage range, section 6.6.1).

6.7.7. **Critical Voltage 12V**

This menu item allows the critical voltage point to be adjusted to a user desired value within the range of 11.0V-12.5V for 12V systems (based on the selected battery voltage range, section 6.6.1).

6.7.8. **Warning Voltage 24V**

This menu item allows the warning voltage point to be adjusted to a user desired value within the range of 24.0V-25.0V for 24V systems (based on the selected battery voltage range, section 6.6.1).

6.7.9. **Critical Voltage 24V**

This menu item allows the critical voltage point to be adjusted to a user desired value within the range of 23.0V-23.9V for 24V systems (based on the selected battery voltage range, section 6.6.1).

6.8. OEM 2 menu

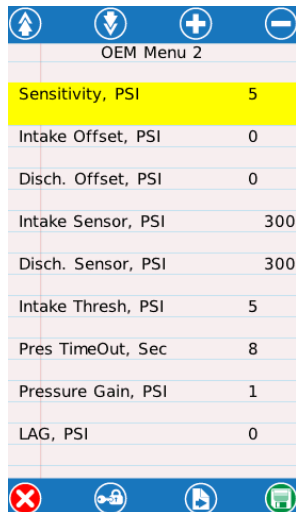

OEM Menu 2	
Sensitivity, PSI	5
Intake Offset, PSI	0
Disch. Offset, PSI	0
Intake Sensor, PSI	300
Disch. Sensor, PSI	300
Intake Thresh, PSI	5
Pres TimeOut, Sec	8
Pressure Gain, PSI	1
LAG, PSI	0

The OEM 2 Menu allows configuration of OEM modifiable items. The OEM 2 menu requires a password (9769).

- Sensitivity Pressure
- Intake Offset Pressure
- Discharge Offset Pressure
- Intake Sensor Pressure
- Discharge Sensor Pressure
- Intake Threshold Pressure
- Pressure time-out
- Pressure gain
- Pressure lag

Use the soft buttons to navigate and modify options.

6.8.1. **Sensitivity (pressure)**

The pressure sensitivity is the amount of pressure change required between the discharge pressure and the target pressure before the pressure control algorithm modifies the engine speed to try and re-establish the discharge pressure to the target pressure. Enter the OEM 2 menu and select "Sensitivity (PSI/kPa/Bar)" then press the INCREASE or DECREASE buttons to change to the desired value (1 to 12 PSI, 6.89476 to 82.7371 kPa, .0689476 to .827371 Bar). Press the SAVE button to save the OEM 2 menu items and exit the menu.

6.8.2. **Intake Offset Pressure**

This menu item allows for adjustment of the intake pressure (-15 to +15 in 1 PSI increments). Enter the OEM 2 menu and select "Intake Offset , (PSI, kPa, Bar)" then press the INCREASE or DECREASE buttons to change to the desired value. Press the SAVE button to save the OEM 2 menu items and exit the menu.

 607 NW 27th Ave Ocala, FL 34475 Ph: 352-629-5020 or 1-800-533-3569 Fax: 352-629-2902 or 1-800-520-3473	TECHNICAL DATA SHEET			PAGE	29 OF 36	
	PRODUCT GROUP	THROTTLE CONTROL	P/N	3045-101-00-CL1, 3045-102-00-CL1	DATE	11/26/2019
	PRODUCT	SENTRY PRESSURE GOVERNOR			REV	1.14
					BY	IMC

6.8.3. Discharge Offset Pressure

This menu item allows for adjustment of the discharge pressure (-15 to +15 in 1 PSI increments). Enter the OEM 2 menu and select "Discharge Offset , (PSI, kPa, Bar)" then press the INCREASE or DECREASE buttons to change to the desired value. Press the SAVE button to save the OEM 2 menu items and exit the menu.

6.8.4. Intake Sensor Range

This menu item allows sets the proper pressure range for the intake sensor to either 300 PSI or 600 PSI (2068 kPa or 4137 kPa, 20.68 Bar or 41.37 Bar). Enter the OEM 2 menu and select "Inlet Sens. Rng (PSI/kPa/Bar)" then press the INCREASE or DECREASE buttons to change to the desired sensor range value. Press the SAVE button to save the OEM 2 menu items and exit the menu.

6.8.5. Discharge Sensor Range

This menu item allows sets the proper pressure range for the discharge sensor to either 300 PSI or 600 PSI (2068 kPa or 4137 kPa, 20.68 Bar or 41.37 Bar). Enter the OEM 2 menu and select "Dis. Sens. Rng (PSI/kPa/Bar)" then press the INCREASE or DECREASE buttons to change to the desired sensor range value. Press the SAVE button to save the OEM 2 menu items and exit the menu.

6.8.6. Intake Threshold

This menu item configures the intake threshold trip point which establishes when the Sentry determines static or positive intake pressure operation. Enter the OEM 2 menu and select "Intake Threshold, (PSI/kPa/Bar)" then press the INCREASE or DECREASE buttons to change to the intake threshold trip point. Press the SAVE button to save the OEM 2 menu items and exit the menu.

6.8.7. Pressure Time-Out (Seconds)

This menu item allows configuration of the low pressure time out. When the SENTRY is governing in pressure mode and the pressure falls below 30 PSI the SENTRY will wait the configured number of seconds to attempt to regain pressure before dropping to IDLE. Enter the OEM 2 menu and select "Press Time-Out (Sec)" then press the INCREASE or DECREASE buttons to change to the desired value (3 to 10 seconds in 1 second increments). Press the SAVE button to save the OEM 2 menu items and exit the menu.

6.8.8. Pressure Gain (pressure change per step)

This menu item allows configuration of the psi change per step. A larger number changes the PSI more with each **INCREASE** or **DECREASE** click of the Twister control knob. Enter the OEM 2 menu and select "Pressure Gain (PSI/kPa/Bar)" then press the INCREASE or DECREASE buttons to change to the desired value (1 to 5 PSI in 1 PSI increments). Press the SAVE button to save the OEM 2 menu items and exit the menu.

6.8.9. LAG (PSI/kPa/Bar)

This menu item allows configuration of the pressure lag which defines the maximum allowable difference that the actual pressure is behind the commanded set-point before a "wait" (catch-up) state is introduced while operating in pressure mode. Enter the OEM 2 menu and select "Lag (PSI/kPa/Bar)" then press the INCREASE or DECREASE buttons to change to the desired value (1 to 20 PSI in 1 PSI increments). Press the SAVE button to save the OEM 2 menu items and exit the menu.

 607 NW 27th Ave Ocala, FL 34475 Ph: 352-629-5020 or 1-800-533-3569 Fax: 352-629-2902 or 1-800-520-3473	TECHNICAL DATA SHEET			PAGE	30 OF 36	
	PRODUCT GROUP	THROTTLE CONTROL	P/N	3045-101-00-CL1, 3045-102-00-CL1	DATE	11/26/2019
	PRODUCT	SENTRY PRESSURE GOVERNOR			REV	1.14
					BY	IMC

6.9. OEM 3 menu

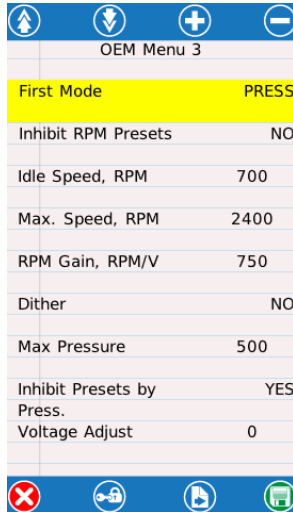

The OEM 3 Menu allows configuration of OEM modifiable items. The OEM 3 menu requires a password (3317).

- First Mode
- Inhibit RPM Presets
- Idle Speed RPM
- Max Speed RPM
- RPM Gain
- Dither
- Max Pressure
- Inhibit Presets by Pressure
- Voltage Adjust

Use the soft buttons to navigate and modify options.

6.9.1. First Operating Mode

This menu item allows configuration of the governor mode active when the MODE button is first pressed. Proper interlocks must be established for the configured first mode to become active during operation. Enter the OEM 3 menu and select “First Mode” then press the INCREASE or DECREASE buttons to change to the desired value (PRESS or RPM). Press the SAVE button to save the OEM 3 menu items and exit the menu.

6.9.2. Inhibit RPM Presets

This menu item allows enabling/disabling of the RPM mode preset usage when pump discharge pressure over 10 PSI is detected. Enter the OEM 3 menu and select “Dis. Sens. Rng (PSI/kPa/Bar)” then press the INCREASE or DECREASE buttons to change to the value (NO or YES). Press the SAVE button to save the OEM 3 menu items and exit the menu.

6.9.3. Idle Engine Speed (RPM)

This menu item allows configuration of the idle speed of the engine. Enter the OEM 3 menu and select “Idle Speed (RPM)” then press the INCREASE or DECREASE buttons to change the desired value (650 to 900 RPM in 1 RPM increments). Press the SAVE button to save the OEM 3 menu items and exit the menu.

6.9.4. Maximum Engine Speed (RPM)

This menu item allows configuration of the maximum speed of the engine. Enter the OEM 3 menu and select “Max. Speed (RPM)” then press the INCREASE or DECREASE buttons to change to the desired value (1900 to 2500 RPM in 25 RPM increments). Press the SAVE button to save the OEM 3 menu items and exit the menu.

6.9.5. Governor Gain (RPM per volt)

This menu item allows configuration of the RPM change per step. A larger number changes the RPM more with each **INCREASE** or **DECREASE** click of the Twister control knob.

Note: Option only available with the Analog control type. This parameter is automatically set by the SENTRY when the Auto Scale routine is run (see section 6.4.4 for more information). Enter the OEM 3 menu and select

 607 NW 27th Ave Ocala, FL 34475 Ph: 352-629-5020 or 1-800-533-3569 Fax: 352-629-2902 or 1-800-520-3473	TECHNICAL DATA SHEET			PAGE	31 OF 36
				DATE	11/26/2019
	PRODUCT GROUP	THROTTLE CONTROL	P/N	3045-101-00-CL1, 3045-102-00-CL1	
	PRODUCT	SENTRY PRESSURE GOVERNOR			REV
				BY	IMC

“Governor Gain (RPM/V)” then press the INCREASE or DECREASE buttons to change to the desired value (250 to 1750 RPM/V in 25 RPM/V increments). Press the SAVE button to save the OEM 3 menu items and exit the menu.

6.9.6. DITHER (Engine handshake)

This menu item allows enabling/disabling of engine handshake. Some engines require constant RPM modification in order to maintain remote RPM control. When enabled, the SENTRY will vary the engine speed +/- 5 RPM around the desired engine speed (CAN communication methods only). Enter the OEM 3 menu and select “Dither” then press the INCREASE or DECREASE buttons to change to the desired value (YES or NO). Press the SAVE button to save the OEM 3 menu items and exit the menu.

6.9.7. Max Pressure

This menu item allows configuration of the maximum pressure of the discharge. Enter the OEM 3 menu and select “Max Pressure” then press the INCREASE or DECREASE buttons to change to the desired value (50 to 600 PSI in 5 PSI increments). Press the SAVE button to save the OEM 3 menu items and exit the menu.

6.9.8. Inhibit Presets by Pressure

This menu item allows the enabling/disabling of the safety feature that requires a minimum amount of discharge before allowing the use of a Preset button. “YES” indicates you require a minimum discharge pressure to use presets, “NO” means you do not.

6.9.9. Voltage Adjust

This menu item allows calibration of the voltage. Enter the OEM 3 menu and select “Voltage Adjust” then press the INCREASE or DECREASE buttons to change to the desired value (-0.5 to +0.5 RPM in .1 V increments). Press the SAVE button to save the OEM 3 menu items and exit the menu.

 607 NW 27th Ave Ocala, FL 34475 Ph: 352-629-5020 or 1-800-533-3569 Fax: 352-629-2902 or 1-800-520-3473	TECHNICAL DATA SHEET			PAGE	32 OF 36	
	PRODUCT GROUP	THROTTLE CONTROL	P/N	3045-101-00-CL1, 3045-102-00-CL1	DATE	11/26/2019
	PRODUCT	SENTRY PRESSURE GOVERNOR			REV	1.14
					BY	IMC

6.10. OEM 4 menu

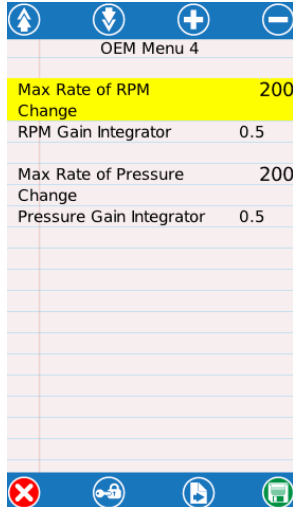

The OEM 4 Menu allows configuration of OEM modifiable items. The OEM 4 menu requires a password (1505).

- Max Rate of RPM Change
- RPM Gain Integrator
- Max Rate of Pressure Change
- Pressure Gain Integrator

Use the soft buttons to navigate and modify options.

6.10.1. Max Rate of RPM Change

This menu item allows modification of the RPM mode response rate of engine adjustment requests (50-800). Adjust this item in conjunction with “Gain Integrator” to fine tune the desired response rate. It is recommended for Cummins to leave this value at the default or keep it near it.

6.10.2. RPM Gain Integrator

This menu item allows modification of the RPM mode response rate of engine adjustment requests (0.01 – 0.9). Adjust this item in conjunction with “Max Rate of Change” to fine tune the desired response rate.

6.10.3. Max Rate of Pressure Change

This menu item allows modification of the PSI mode response rate of engine adjustment requests (50-800). Adjust this item in conjunction with “Gain Integrator” to fine tune the desired response rate. It is recommended for Cummins to leave this value at the default or keep it near it.

6.10.4. Pressue Gain Integrator

This menu item allows modification of the PSI mode response rate of engine adjustment requests (0.1 – 0.9). Adjust this item in conjunction with “Max Rate of Change” to fine tune the desired response rate.

 607 NW 27th Ave Ocala, FL 34475 Ph: 352-629-5020 or 1-800-533-3569 Fax: 352-629-2902 or 1-800-520-3473	TECHNICAL DATA SHEET			PAGE	33 OF 36
				DATE	11/26/2019
PRODUCT GROUP	THROTTLE CONTROL	P/N	3045-101-00-CL1, 3045-102-00-CL1	REV	1.14
PRODUCT	SENTRY PRESSURE GOVERNOR			BY	IMC

6.11. FACT menu 1

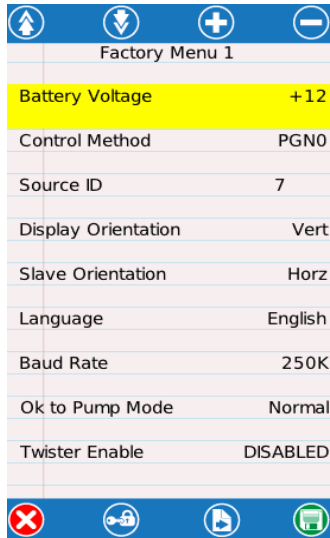

The Factory Menu 1 allows configuration of the Control method, Slave settings, Languages and baud rate. The Factory Menu requires a password (6679).

- Battery Voltage
- Control Method
- Source ID
- Display Orientation
- Slave Orientation
- Language
- Baud Rate
- Ok to Pump Mode
- Twister Enable

Use the soft buttons to navigate and execute options.

6.11.1. Battery Voltage Range

Enter the FACT 1 menu and select “Batt. Voltage (volts)” then press the INCREASE or DECREASE buttons to change to the desired value (+12 or +24). Press the SAVE button to save the FACT 1 menu items and exit the menu.

6.11.2. Engine Control Method

This menu item allows configuration of the engine control type.

CFPG – **C**ummins **F**ire **P**ressure **G**overnor, uses Cummins proprietary control message via CAN to control engine speed.

PGN0 – Uses J1939, PGN0 – Torque Speed Control message to control engine speed.

SN-BWS – **SCAN**ia, uses the Scania Bodywork Control Message 1.

SN-BCI – SCANia, uses the Scania Body Control Interface Control Message.

ANLG – Uses analog voltage signal to control remote throttle input on engine.

MERC – Specific J1939 messaging structure for certain Mercedes applications.

MAN – Specific MAN engines J1939 control message.

V-FMFH – Volvo FM/FH messaging.

V-FEFL – Volvo FE/FL messaging.

FAW – FAW control messaging

SLAV – Is the second Sentry on the vehicle (slave).

Enter the FACT 1 menu and select “Control Method” then press the INCREASE or DECREASE buttons to change to the desired value (CFPG, PGN0, SN-BWS, SN-BCI, ANLG, MERC, MAN, V-FMFM, V-FEFL, FAW, SLAV). Press the SAVE button to save the FACT 1 menu items and exit the menu.

6.11.3. CAN Source ID

This menu item allows configuration of the source address for the PGN0 engine communication method. Enter the FACT 1 menu and select “Source ID” then press the INCREASE or DECREASE buttons to change to the desired address number (0-79). Press the SAVE button to save the FACT 1 menu items and exit the menu.

 607 NW 27th Ave Ocala, FL 34475 Ph: 352-629-5020 or 1-800-533-3569 Fax: 352-629-2902 or 1-800-520-3473	TECHNICAL DATA SHEET			PAGE	34 OF 36	
	PRODUCT GROUP	THROTTLE CONTROL	P/N	3045-101-00-CL1, 3045-102-00-CL1	DATE	11/26/2019
	PRODUCT	SENTRY PRESSURE GOVERNOR			REV	1.14
					BY	IMC

6.11.4. Display Orientation

This menu item allows configuration of the Orientation of the Display from Horizontal to Vertical. Horz equals horizontal and Vert equals vertical.

6.11.5. Slave Orientation

This menu item allows configuration of the Orientation of the Slave Display from Horizontal to Vertical. Horz equals horizontal and Vert equals vertical.

6.11.6. Language

This menu item allows configuration of the language that is being used. Available languages include English, German, French, Spanish, Portuguese, Russian, Polish, Thai, Greek, and Chinese.

6.11.7. Baud Rate

This menu item allows configuration of the Baud Rate that is used on the CAN bus. 125K indicates the Sentry will communicate at 125K Baud Rate, 250K indicates the Sentry will communicate at 250K Baud Rate, and 500K indicates the Sentry will communicate at 500K Baud Rate. Slave Displays auto acquire the Master's Baud Rate.

6.11.8. Ok to Pump Mode

This menu item allows configuration of the Ok to Pump Mode either Normal or Special. When in Normal mode OEM and Pump Engaged Interlocks with activate the Ok to Pump Interlock. In Special mode Okay to Pump interlock is activated from the Sentry's IO.

6.11.9. Twister Enable

This menu item allows configuration of a Twister throttle module to be used in conjunction with the Sentry. When disabled the Sentry will not look for or listen to Twister commands.

6.12. FACT menu 2

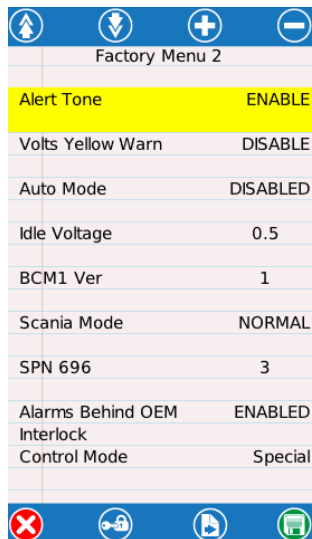

Factory Menu 2	
Alert Tone	ENABLE
Volts Yellow Warn	DISABLE
Auto Mode	DISABLED
Idle Voltage	0.5
BCM1 Ver	1
Scania Mode	NORMAL
SPN 696	3
Alarms Behind OEM Interlock	ENABLED
Control Mode	Special

The Factory Menu 2 allows configuration various menu options. The Factory Menu 2 requires a password (7081).

- Alert Tone
- Voltage Yellow Warning
- Auto Mode
- Idle Voltage
- BCM1 Version
- Scania Mode
- SPN 696
- Alarms behind OEM Interlock
- Control Mode

Use the soft buttons to navigate and execute options.

 607 NW 27th Ave Ocala, FL 34475 Ph: 352-629-5020 or 1-800-533-3569 Fax: 352-629-2902 or 1-800-520-3473	TECHNICAL DATA SHEET			PAGE	35 OF 36
	PRODUCT GROUP	THROTTLE CONTROL	P/N	3045-101-00-CL1, 3045-102-00-CL1	DATE
PRODUCT	SENTRY PRESSURE GOVERNOR			REV	1.14
				BY	IMC

6.12.1. Set the Warning Alert Tone

Enter the FACT 2 menu and select “Warn. Alert Tone” then press the INCREASE or DECREASE buttons to change to the desired value (ENABLE, DISABLE). Press the SAVE button to save the FACT 2 menu items and exit the menu.

6.12.2. Volts Yellow Warn

This menu item enables or disables the low battery warning message. When the warning is disabled there will only be one low battery voltage level which is the critical point.

6.12.3. Auto Mode

This menu item allows configuration of automatically entering pressure mode when pump engagement occurs (Auto Mode = ENABLED). Note that this option will only be available if the 1st mode parameter (section 6.9.1) is set to pressure mode. When this parameter is enabled, the governor will be put in pressure mode when the pump is changed from a disengaged to an engaged position (interlocks permitting). Thereafter, when a user selects the IDLE (standby) mode, the governor will remain in standby mode until a new mode is selected or the Twister knob is turned in the “increase” direction (interlocks permitting).

Enter the FACT 2 menu and select “Auto Mode” then press the INCREASE or DECREASE buttons to change to the desired value (ENABLED, DISABLED). Press the SAVE button to save the FACT 2 menu items and exit the menu.

6.12.4. Idle Voltage

This menu item allows configuration of the analog idle offset voltage, displayed in “volts”. This option is only available with the Analog Engine Control Method (section 6.11.2).

Note: This parameter is automatically set by the SENTRY when the Auto Scale routine is run (see section 6.4.4 for more information).

Enter the FACT 2 menu and select “Idle Voltag (Volts)” then press the INCREASE or DECREASE buttons to change to the desired value (0 to 5 volts in 0.1 volt increments). Press the SAVE button to save the FACT 2 menu items and exit the menu.

6.12.5. BCM1 VER (Body Control Message 1 version)

This menu item allows configuration of the message configuration version transmitted in the Scania Body Control Message 1. Enter the FACT 2 menu and select “BCM1 Ver” then press the INCREASE or DECREASE buttons to change to the desired value (1 to 255). Press the SAVE button to save the FACT 2 menu items and exit the menu.

6.12.6. Scania Mode (Scania governor type)

This menu item allows configuration of the Scania requested governor type in the Body Control Message 1. Enter the FACT 2 menu and select “Scania Mode” then press the INCREASE or DECREASE buttons to change to the desired value (NORMAL or STIFF). Press the SAVE button to save the FACT 2 menu items and exit the menu.

6.12.7. SPN 696

This menu item allows the configuration of the CAN Engine Requested Speed Control Condition. The possible values are:

0. Transient optimized for driveline disengaged and non-lockup conditions.
1. Stability optimized for driveline disengaged and non-lockup conditions.
2. Stability optimized for driveline engaged and/or and in lockup condition 1 (e.g. vehicle driveline).
3. Stability optimized for driveline engaged and/or and in lockup condition 2 (e.g. PTO driveline).

 607 NW 27th Ave Ocala, FL 34475 Ph: 352-629-5020 or 1-800-533-3569 Fax: 352-629-2902 or 1-800-520-3473	TECHNICAL DATA SHEET			PAGE	36 OF 36
	PRODUCT GROUP	THROTTLE CONTROL	P/N	3045-101-00-CL1, 3045-102-00-CL1	DATE
PRODUCT	SENTRY PRESSURE GOVERNOR			REV	1.14
				BY	IMC

6.12.8. Alarms behind OEM Interlock

This menu item allows configuration of the when warning and error messages can appear on the main screen. Enabling this menu option will prevent any alarms that were activated, prior to the OEM interlock being engaged, from appearing.

6.12.9. Control Mode

This menu item allows configuration of the Engine Control messages (Special, Normal). "Special" is the legacy send while Normal requires at least an interlock be made before control messages are transmitted by the Sentry.

7. Configuration

7.1. Configure the IDLE voltage and GAIN setting using Auto Scale (Analog engines)

A SENTRY set to Analog control mode (see section 6.11.2) may use the Auto Scale configure method to automatically set the IDLE voltage (6.12.4) and GAIN setting (6.9.5).

The engine must be running and the interlocks (as defined in section 4.3) must be enabled when running the Auto Scale mode.



The SENTRY will actively control the engine RPM during Auto Scale. Make certain that all operational precautions are observed and a trained operator is present.

Enter the INFO menu (section 6.3) and select "AutoScale Analog Output" then press the SAVE button. The display will prompt you to verify that you want to set the Auto Scale the analog output. Press the green ACCEPT button to start or the red cancel button to not start. If the engine control method is not set for "analog" a warning will be shown and Auto Scale will not be attempted. Once back to the INFO menu you must press the SAVE button to save the Auto Scale operation and exit the menu.

 607 NW 27th Ave Ocala, FL 34475 Ph: 352-629-5020 or 1-800-533-3569 Fax: 352-629-2902 or 1-800-520-3473	TECHNICAL DATA SHEET			PAGE	37 OF 36
	PRODUCT GROUP	THROTTLE CONTROL	P/N	3045-101-00-CL1, 3045-102-00-CL1	DATE
PRODUCT	SENTRY PRESSURE GOVERNOR			REV	1.14
				BY	IMC

8. Using a Twister with the Sentry

8.1. Overview

The Twister Electronic Throttle (p/n 119970) is an SAE J1939 Controller Area Network (CAN) device that controls engine speed using data communications directly to the engine ECU for remote throttle applications. The Twister supports three CAN message formats: Torque/Speed Control 1 (TSC1) PGN 0 CAN message, Cummins Fire Pump Governor (CFPG), and Scania Body Control message.

Control algorithms are optimized to take advantage of the J1939 CAN data to yield crisp and accurate control of engine.

The Twister utilizes Light Emitting Diodes (LED) to convey status information to the operator. The green **THROTTLE READY** LED is on the left-side of the control knob and the blue **ACTIVE** LED is on the right-side of the control knob. The Twister has a control knob and an idle button for the operator to control engine speed. The control knob allows manipulation of the engine speed within the configured (and engine allowable) RPM range. The idle button returns the engine speed to the configured idle RPM.



Figure 3. *Twister controls and indicators.*

8.2. Ready indicator

The green **READY** indicator shows the status Sentry throttle ready interlock.

8.3. Active indicator

The blue **READY** indicator indicates that the Twister is ready to control the Sentry. This is mainly used with dual-governor applications to indicate which governor is active for user operation.

8.4. Control knob

The control knob is the operator's interface for controlling the Sentry's engine speed (throttle mode) and target pressure (pressure mode). The control knob can be configured to increase engine speed/target pressure with clockwise or counter-clockwise rotation (see section 6.6.1).

8.5. Idle button

The Twister's idle button performs the same task as the idle button on the Sentry. Press and hold this button for **one second** while in rpm mode or pressure mode to force the engine to ramp down to its idle position.

 607 NW 27th Ave Ocala, FL 34475 Ph: 352-629-5020 or 1-800-533-3569 Fax: 352-629-2902 or 1-800-520-3473	TECHNICAL DATA SHEET			PAGE	38 OF 36
	PRODUCT GROUP	THROTTLE CONTROL	P/N	3045-101-00-CL1, 3045-102-00-CL1	DATE
PRODUCT	SENTRY PRESSURE GOVERNOR			REV	1.14
				BY	IMC

8.6. Twister operation in Sentry modes

The Twister can control the Sentry in its operating modes: **throttle mode** (RPM), **pressure mode** (PSI) and **hi-idle mode** (HIDLE).

8.6.1. Throttle mode operation



Rotate the Twister knob in the **INCREASE** direction to increase or the **DECREASE** direction to decrease the engine RPM set point. The direction of increase can be set to clockwise or counter-clockwise (see section 6.6.1).



Press the **IDLE** button at any time to set the SENTRY back to standby. Both mode indicator LEDs will turn off when the engine speed reaches idle (see section 4.5).

8.6.2. Pressure mode



Rotate the Twister knob in the **INCREASE** direction to increase or the **DECREASE** direction to decrease the pressure set point. The direction of increase can be set to clockwise or counter-clockwise (see section 6.6.1). The target pressure will be displayed in the target pressure display.



Press the **IDLE** switch at any time to set the SENTRY back to standby. Both mode indicator LEDs will turn off when the engine speed reaches idle (see section 4.5).

8.6.3. High Idle mode



Press the **IDLE** button at any time to set the SENTRY back to standby. Both mode indicator LEDs will turn off when the engine speed reaches idle (see section 4.5).

 <p>607 NW 27th Ave Ocala, FL 34475 Ph: 352-629-5020 or 1-800-533-3569 Fax: 352-629-2902 or 1-800-520-3473</p>	TECHNICAL DATA SHEET			PAGE	39 OF 36	
	PRODUCT GROUP	THROTTLE CONTROL	P/N	3045-101-00-CL1, 3045-102-00-CL1	DATE	11/26/2019
	PRODUCT	SENTRY PRESSURE GOVERNOR			REV	1.14
					BY	IMC

8.7. List of warning/error messages

If a Twister is configured for use with a Sentry two potential warnings/errors become possible.

MESSAGE	DESCRIPTION	SENTRY RESPONSE	OPERATOR ACTION
Primary Twister Communication Timeout Fault	The SENTRY is not receiving CAN communication from the Twister device.	<i>No change in operation.</i>	<i>Operator may continue to use SENTRY but only presets and idle will function.</i>
Secondary Twister Communication Timeout Fault	The SENTRY is not receiving CAN communication from the secondary Twister device.	<i>No change in operation.</i>	<i>Operator may continue to use SENTRY but only presets and idle will function.</i>

8.8. Configure the Twister for operation with the Sentry

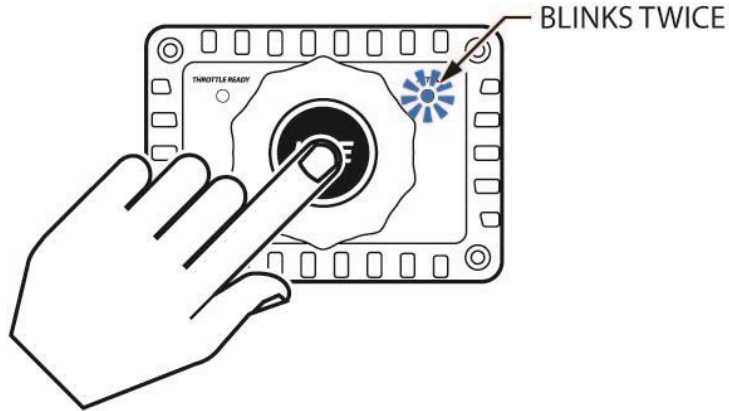

1. Press and hold the IDLE button until the ACTIVE LED blinks twice (two seconds). Continue holding the IDLE button while entering the password.
2. [Set the Twister to Sentry mode] Use the knob to enter the password:



NOTE: A clockwise ↻ rotation will turn the ACTIVE LED ON for a half- second and a counter-clockwise ↺ rotation will turn the THROTTLE READY LED ON for a half-second. Wait for the LED indication to turn OFF before rotating the knob again. A rotation consists of at least one tactile click and a single rotation event is complete when the knob remains stationary for at least half a second.

 <p>607 NW 27th Ave Ocala, FL 34475 Ph: 352-629-5020 or 1-800-533-3569 Fax: 352-629-2902 or 1-800-520-3473</p>	TECHNICAL DATA SHEET			PAGE	40 OF 36	
	PRODUCT GROUP	THROTTLE CONTROL	P/N	3045-101-00-CL1, 3045-102-00-CL1	DATE	11/26/2019
	PRODUCT	SENTRY PRESSURE GOVERNOR			REV	1.14
					BY	IMC

9. Mounting & installation

9.1. Panel cutout dimensions (Sentry)

Mount the Sentry on the operator's panel with four #6 screws and nuts.

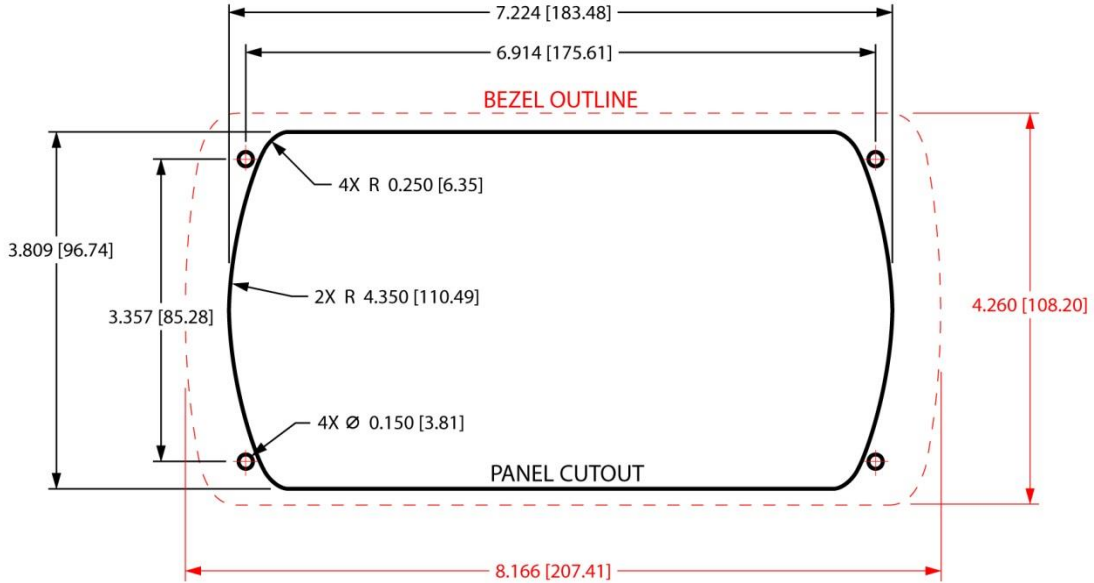

Figure 4. Installation dimensions in inches [millimeters].

9.2. Panel cutout dimensions (Twister)

Mount the Twister on the operator's panel with four #6 screws and nuts.

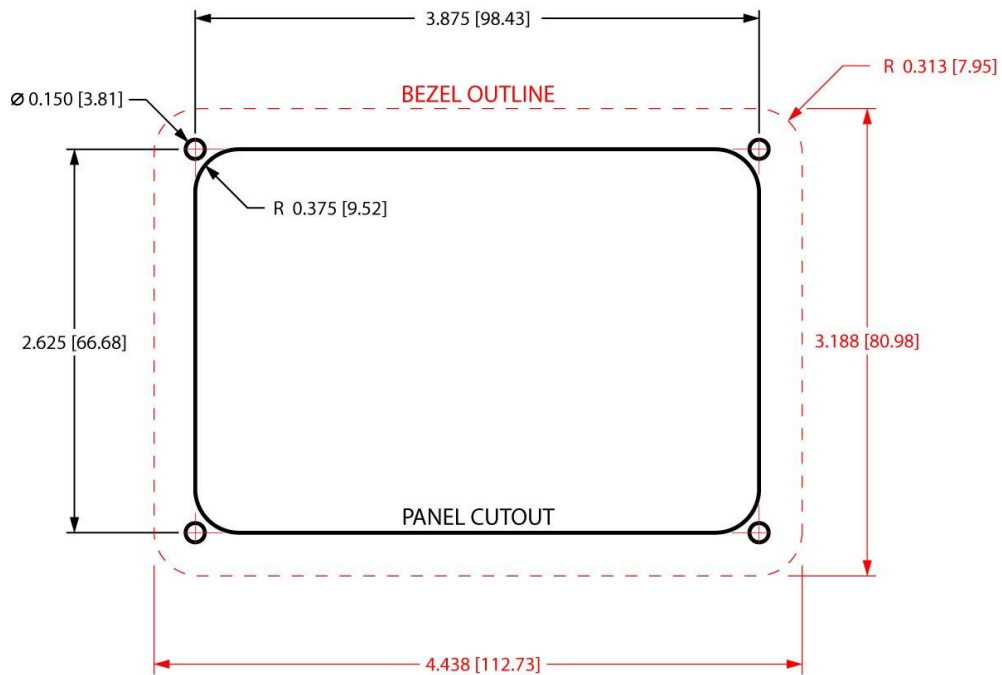



Figure 5. Installation dimensions in inches [millimeters].

 <p>607 NW 27th Ave Ocala, FL 34475 Ph: 352-629-5020 or 1-800-533-3569 Fax: 352-629-2902 or 1-800-520-3473</p>	TECHNICAL DATA SHEET			PAGE	41 OF 36
	PRODUCT GROUP	THROTTLE CONTROL	P/N	3045-101-00-CL1, 3045-102-00-CL1	DATE
PRODUCT	SENTRY PRESSURE GOVERNOR			REV	1.14
				BY	IMC

10. Connector Description

10.1. SENTRY connectors

The module has four connectors and the following definitions apply:

Mating connector: Deutsch DT06-6SA GRAY Mating sockets: Deutsch 0462-201-16141 Gold mating sockets: Deutsch 0462-201-1631 Wedge lock: W6S2-P012 Recommended wire gage: 16-20 AWG		
PIN	CIRCUIT	DESCRIPTION
1	Sensor SIGNAL	(INPUT) – Intake pressure signal (+0.5VDC to +4.5VDC)
2	Sensor SIGNAL	(INPUT) – Discharge pressure signal (+0.5VDC to +4.5VDC)
3	Sensor +5 REF	(OUTPUT) – Intake pressure supply (+5VDC)
4	PUMP INTLK	(INPUT) – pump engaged interlock (positive polarity)
5	Throttle EN	(OUTPUT) – remote throttle activate (ground polarity)
6	Sensor gnd REF	(OUTPUT) – Intake pressure ground

Mating connector: Deutsch DT06-6SA GRAY Mating sockets: Deutsch 0462-201-16141 Gold mating sockets: Deutsch 0462-201-1631 Wedge lock: W6S Recommended wire gage: 16-20 AWG		
PIN	CIRCUIT	DESCRIPTION
1	ENG REF (+)	(INPUT) – analog signal reference (+5VDC)
2	THROT INTLK	(INPUT) – throttle ready interlock (positive polarity)
3	HI IDLE	(INPUT) – high idle enable (positive polarity)
4	ENG SIGNAL	(OUTPUT) – analog signal control (+0.5VDC to +4.5VDC)
5	OK2P INTLK	(INPUT) – okay to pump interlock (positive polarity)
6	ENG REF (-)	(INPUT) – analog signal reference (ground)

Mating connector: Deutsch DT06-6SA GRAY Mating sockets: Deutsch 0462-201-16141 Gold mating sockets: Deutsch 0462-201-1631 Wedge lock: W6S Recommended wire gage: 16-20 AWG		
PIN	CIRCUIT	DESCRIPTION
1	SUPPLY (+)	(INPUT) – battery voltage (+9VDC...+32VDC)
2	CAN HIGH	(DATA) – SAE J1939 CAN 2.0B, 250Kbits/s
3	CAN LOW	(DATA) – SAE J1939 CAN 2.0B, 250Kbits/s
4	CAN SHIELD	(DATA) – SAE J1939 CAN 2.0B, 250Kbits/s
5	SUPPLY (+)	(INPUT) – battery voltage (+9VDC...+32VDC)
6	SUPPLY (-)	(INPUT) – battery ground

Mating connector: Deutsch DT06-6SA GRAY Mating sockets: Deutsch 0462-201-16141 Gold mating sockets: Deutsch 0462-201-1631 Wedge lock: W6S2-P012 Recommended wire gage: 16-20 AWG		
PIN	CIRCUIT	DESCRIPTION
1	USB +5V	Programming only
2	USB D+	Programming only
3	USB D-	Programming only
4	ALARM (-)	(OUTPUT) – alarm active (ground polarity, 250mA)
5	USB Shield	Programming only
6	USB GND	Programming only

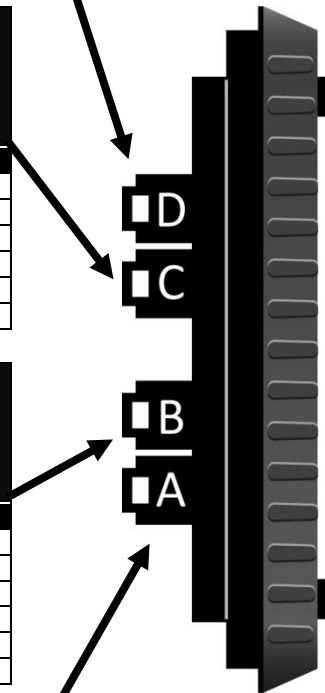

 607 NW 27th Ave Ocala, FL 34475 Ph: 352-629-5020 or 1-800-533-3569 Fax: 352-629-2902 or 1-800-520-3473	TECHNICAL DATA SHEET			PAGE	42 OF 36	
	PRODUCT GROUP	THROTTLE CONTROL	P/N	3045-101-00-CL1, 3045-102-00-CL1	DATE	11/26/2019
	PRODUCT	SENTRY PRESSURE GOVERNOR			REV	1.14
					BY	IMC

10.2. Pressure sensor connector

The pressure sensors (intake and discharge) have one connector and the following definitions apply:

Mating connector:		Packard 12078090
Mating sockets:		Packard 12089290
Recommended wire gage: 16-20 AWG		
PIN	CIRCUIT	DESCRIPTION
A	SUPPLY (-)	(INPUT) – pressure sensor ground
B	SUPPLY (+)	(INPUT) – pressure sensor supply (+5VDC)
C	Signal	(OUTPUT) – pressure sensor signal (+0.5VDC to +4.5VDC)

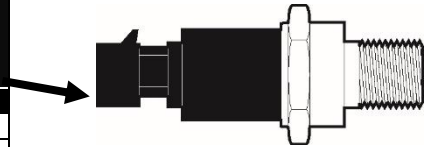

10.3. Twister connector

The module has one connector and the following definitions apply:

Mating connector:		Deutsch DT06-6S GRAY
Mating sockets:		Deutsch 0462-201-16141
Gold mating sockets:		Deutsch 0462-201-1631
Recommended wire gage:		16-20 AWG
Wedge lock:		W6S
PIN	CIRCUIT	DESCRIPTION
1	SYS POWER	(INPUT) – battery voltage (+9VDC...+32VDC)
2	SYS GROUND	(INPUT) – battery ground
3	----	Not used
4	CAN HIGH	(DATA) – SAE J1939 CAN 2.0B, 250Kbits/s
5	CAN LOW	(DATA) – SAE J1939 CAN 2.0B, 250Kbits/s
6	CAN SHIELD	(DATA) – SAE J1939 CAN 2.0B, 250Kbits/s

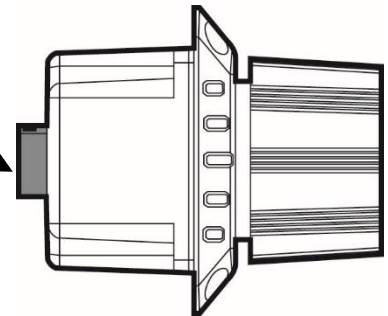

 607 NW 27th Ave Ocala, FL 34475 Ph: 352-629-5020 or 1-800-533-3569 Fax: 352-629-2902 or 1-800-520-3473	TECHNICAL DATA SHEET			PAGE	43 OF 36
				DATE	11/26/2019
PRODUCT GROUP	THROTTLE CONTROL	P/N	3045-101-00-CL1, 3045-102-00-CL1	REV	1.14
PRODUCT	SENTRY PRESSURE GOVERNOR			BY	IMC

11. Technical Details

Product category	ES-Key network (SAE J1939 CAN)		
Voltage range	+9VDC...+32VDC		
Maximum current draw	Logic supply+ input (pin 1 of connector B)		
@13.8VDC	240 mA		
@27.6VDC	120 mA		
Maximum output current			
Sensor (+5VDC) References	250mA		
Alarm active	250mA (ground polarity output)		
Temperature range	-40°C...+85°C		
Environmental range	IP 67		
CAN specification	SAE J1939, 250 Kbits/second		
Electrical protection	Internal thermal fuse (2500mA on pin 1 of black 12-pin connector)		
	CAN bus protected for heavy duty trucks (24V)		
	Transient voltage protected to SAE J1113 specification for heavy duty trucks (24V)		
	Load dump voltage protected to SAE J1113 specification for heavy duty trucks (24V)		
Electrical performance	Immunity to Radiated Electromagnetic Fields– Bulk Current Injection (BCI) method, Class C device	SAE J1113-4	
	Reverse voltage protection on power leads (pins 1 and 12 of black 12-pin connector), Class C device	ISO 16750-2	
	Jump start on power leads, Class C device	ISO 16750-2	
	Immunity to conducted transients on power leads, Class C device (24V)	SAE J1113-11	
	Immunity to Electrostatic Discharge – powered and unpowered modes	SAE J1113-13	
	Immunity to radiated electromagnetic fields	SAE J1113-21	
	Conducted emission on power leads (level 3 limits)	SAE J1113-41	
	Radiated emissions, absorber-lined shielded enclosure (level 2 limits)	SAE J1113-41	
	Reset behavior on voltage drop 24V, Class C device	ISO 16750-2	
	Environmental performance	Exposure to fungus	MIL-STD-810F (method 508.5) SAE J1455 (sec 4.6)
Thermal shock		SAE J1455 (sec 4.1.3.2)	
Exposure to humidity		MIL-STD-810F (method 507.4)	
Thermal shock due to splash		Class 1 (STD-0001)	
Steam cleaning		SAE J1455 (sec 4.4)	
Exposure to salt spray atmosphere/fog		SAE J1455 (sec 4.3)	
Exposure to splash due to chemicals and oils		SAE J1455 (sec 4.4)	
Exposure to outdoor UV		ISO 4892-2 (method A)	
Mechanical performance		Resonance dwell	SAE J1455 (sec 4.9.4.1)
		Random vibration	SAE J1455 (sec 4.9.4.2)
	Mechanical shock	SAE J1455 (sec 4.10.3.4)	

 607 NW 27th Ave Ocala, FL 34475 Ph: 352-629-5020 or 1-800-533-3569 Fax: 352-629-2902 or 1-800-520-3473	TECHNICAL DATA SHEET			PAGE	44 OF 36	
	PRODUCT GROUP	THROTTLE CONTROL	P/N	3045-101-00-CL1, 3045-102-00-CL1	DATE	11/26/2019
	PRODUCT	SENTRY PRESSURE GOVERNOR			REV	1.14
					BY	IMC



Ford F-Series Chassis Remote Throttle SB-143

August 3, 2017

Ford F-Series Chassis Equipped with Fire Pump Driven from Chassis For Emergency Vehicle Applications

IMPORTANT INFORMATION

Dear Valued Class1 Pressure Governor and/or Throttle Customer,

Hale is issuing this notice to advise you of some features that are particular to the Ford F-series chassis used in your emergency vehicle. These features may be different from other medium and heavy duty chassis that you are used to in other emergency vehicles and that could affect the remote (pump/PTO) throttle.

While pumping or operating in split shaft/PTO mode, do not press the accelerator pedal or brake pedal. If the accelerator pedal or brake pedal is pressed while in split shaft/PTO mode, the engine will return to curb idle and control of the remote throttle or governor will be lost. This will cause the pump to be reduced to idle and water pressure will be reduced.

Please note, this functionality is normal and particular to the Ford F-Series chassis. It is not due to any issue with the operation of the pressure governor, the remote throttle or the pump installation.

If the brake pedal or accelerator pedal/throttle is inadvertently pressed while pumping or operating in split shaft/PTO mode, the operator can reactivate the remote throttle by disengaging and reengaging the PTO/pump from the control located in the cab..

Please note all of the above information in your standard operating guidelines and in all training.

 607 NW 27th Ave Ocala, FL 34475 Ph: 352-629-5020 or 1-800-533-3569 Fax: 352-629-2902 or 1-800-520-3473	TECHNICAL DATA SHEET			PAGE	45 OF 36	
	PRODUCT GROUP	THROTTLE CONTROL	P/N	3045-101-00-CL1, 3045-102-00-CL1	DATE	11/26/2019
	PRODUCT	SENTRY PRESSURE GOVERNOR			REV	1.14
					BY	IMC

Ford F-Series Chassis Remote Throttle SB-143

For your reference, there are several enablers and disablers surrounding the Split Shaft PTO operation for the F-Series chassis. Below is an excerpt from the Ford Trucks *Body Builders Layout Book*.

Reprinted from Ford Motor Company Documentation

Split Shaft Mode/ Live Drive Mobile Mode Enable-Disable Conditions (Diesel only)			
Vehicle Conditions to Enable Split Shaft / Mobile (Live Drive)	Vehicle Conditions that Disable Split Shaft/ Live Drive (any one required - See Note-1)	Split Shaft Mode	Live Drive
Parking brake applied.	Parking brake disengaged.	Yes	No
Foot off of service brake	Depressing service brake	See note-2	No
Vehicle in PARK	Vehicle taken out of PARK	See note-2	No
Foot off of accelerator pedal	Accelerator pedal depressed	Yes	No
Vehicle speed is 0 mph (stationary)	Vehicle speed is not 0 mph (stationary)	Yes	No
Engine at a stable base idle speed		Yes	No
Transmission oil Temp above 20° F	Transmission Oil Temperature (TOT) exceeds 240° F.	Yes	Yes
Engine Coolant Temperature (ECT) 20° F minimum	Engine Coolant Temperature (ECT) exceeds 234° F	Yes	Yes
	Catalyst Temperature Limit	Yes	Yes

(1) A "change-of-state" at the "PTO-Request" circuit is required to re-invoke Split Shaft / Live Drive. When a disabler is seen by the PCM the "PTO-Indicator" circuit changes from "ground-source" to "open-circuit", the PTO mode drops out, and the engine speed returns to base idle. To re-initiate Split shaft / Live Drive the operator must turn off the aftermarket PTO switch (removing command voltage to the "PTO-Mode" circuit) and turn it back on again.

(1) Please see Split Shaft PTO in Special Situations.

For complete details regarding the split shaft operation on the Ford F-Series line of trucks please refer to the *Body Builders Layout Book* provided by Ford Trucks or contact your local Ford Truck dealer.

Hale Products strives to provide our customers with the highest performing, most advanced and dependable products to meet the extraordinary demands of the fire service industry. We are