

Weather Pro *Power Awning*

WeatherPro Hardware

8551101.40(X)(X) Basement Hardware

8551102.40(X)(X) Standard Hardware

8551103.40(X)(X) 5th Wheel Basement Hardware

8551104.40(X)(X) 5th Wheel Standard Hardware

FOR

905(XX)(XX.XX)(X)(X)

8(X)5(XX)(XX.XX)(X)(X)

Fabric Roller Tube Assembly

USA

SERVICE OFFICE
Dometic Corporation
2320 Industrial Parkway
Elkhart, IN 46516
574-294-2511

CANADA

Dometic Corporation
46 Zatonski, Unit 3
Brantford, ON N3T 5L8
CANADA
519-720-9578

For Service Center

Assistance Call:

800-544-4881

WARNING

This manual must be read and understood before installation, adjustment, service, or maintenance is performed. This unit must be installed by a qualified service technician. Modification of this product can be extremely hazardous and could result in personal injury or property damage.

AVERTISSEMENT

Lire et comprendre ce manuel avant de procéder à l'installation, à des réglages, de l'entretien ou des réparations. L'installation de cet appareil doit être effectuée par un réparateur qualifié. Toute modification de cet appareil peut être extrêmement dangereuse et entraîner des blessures ou dommages matériels.

INSTALLATION INSTRUCTIONS

MODEL

905(XX)(XX.XX)(X)(X)FRTA
8(X)5(XX)(XX.XX)(X)(X)FRTA
855110(X).40(X)(X)
Hardware

REVISION

Form No. 3309523.011 7/05

(French 3309578.015)

©2005 Dometic Corporation

LaGrange, IN 46761

Important: These instructions must stay with unit. Owner read carefully.

SAFETY INSTRUCTIONS

This manual has safety information and instructions to help users eliminate or reduce the risk of accidents and injuries.

RECOGNIZE SAFETY INFORMATION



This is the safety-alert symbol. When you see this symbol in this manual, be alert to the potential for personal injury.

Follow recommended precautions and safe operating instructions.

UNDERSTAND SIGNAL WORDS

A signal word, **WARNING OR CAUTION** is used with the safety-alert symbol. They give the level of risk for potential injury.

WARNING indicates a potentially hazardous situation which, if not avoided, could result in death or serious injury.

CAUTION indicates a potentially hazardous situation which, if not avoided, may result in minor or moderate injury.

CAUTION used without the safety alert symbol indicates, a potentially hazardous situation which, if not avoided, may result in property damage.

Read and follow all safety information and instructions.

GENERAL INFORMATION

COVERED BY PATENT 5383346, 4941524, D366763,
6095221, 6230783, D414880, 6164883, 6276424,
6230786, D410192, D429894, 6273172 & 6798158
OTHER PATENTS PENDING

REQUIRED PARTS (Packed with each Hardware Assembly)

8551101.40(X)(X) & 8551102.40(X)(X) Hardware

- (2) Top Mounting Bracket Cover (3108404.009(X))
- (2) Bottom Bracket Cover (3109752.000(X))
- (4) #14-10 x 2-3/4" Hex Head Screw (3104499.094)
- (4) #14-10 x 2" Hex Head Screw (3104499.086)
- (2) .25" Split Lock Washer (3101746.000)
- (4) #10-16 x 3/4" Hex Washer Head Self Drilling Screw (310359.013)
- (4) 3/16" x 1" Oscar Rivets (113008)
- (2) #6-20 x .44" Hex Washer Head Self Drilling Screw (310359.012)
- (1) 1/4"- 20 x 3/4" Hex Head Bolt (3104176.205)
- (1) 1/4"-20 x 1.25" SS Screw, Hex Cap (3104176.213)
- (1) 1/4"-20 SS Lock Nut W/Insert (317534.006)
- (2) Spacer (3307943.005(X))
- (1) Spacer (309513.045)

8551103.40(X)(X) & 8551104.40(X)(X) Hardware

- (2) Bottom Bracket Cover (3109752.000(X))
- (4) #14-10 x 1-1/2" Hex Head Screw (3104499.003)
- (4) #14-10 x 2" Hex Head Screw (3104499.086)
- (2) .25" Split Lock Washer (3101746.000)
- (4) #10-16 x 3/4" Hex Washer Head Self Drilling Screw (310359.013)
- (4) 3/16" x 1" Oscar Rivets (113008)
- (2) #6-20 x .44" Hex Washer Head Self Drilling Screw (310359.012)
- (1) 1/4"- 20 x 3/4" Hex Head Bolt (3104176.205)
- (1) 1/4"-20 x 1.25" SS Screw, Hex Cap (3104176.213)
- (1) 1/4"-20 SS Lock Nut W/Insert (317534.006)
- (2) Spacer (3307943.005(X))
- (1) Spacer (309513.045)

When Installing Electronic Control Kit Number 3309424.004 the following connectors, pins, sockets, and wiring will need to be supplied by installer:

- (4) 350766-1 Plug (3 position)
- (6) 350777-1 Plug (2 position)
- (1) 350779-1 Plug (4 position)
- (6) 350689-1 Socket (18-24 gauge)
- (5) 350550-1 Socket (14-20 gauge)
- (2) 640310-1 Socket (10-12 gauge)
- (14) 350547-1 Pin (14-20 gauge)

When Installing Electronic Control Kit Number 3309424.012 the following Wire Harness Kit (3309741.001) will be supplied, but wiring will need to be supplied by installer.

- (2) 3309726.002 Wire Harness, Limit Switch
- (2) 3309726.010 Wire Harness, Patio Motor
- (2) 3309726.028 Wire Harness, Door Motor
- (2) 3309726.036 Wire Harness, Wind Sensor
- (1) 3309726.044 Wire Harness, Patio Remote Switch
- (1) 3309726.051 Wire Harness, Door Remote Switch
- (1) 3309726.067 Wire Harness, 12 VDC Power

Important: Read and understand ALL of the following steps before beginning installation.

Application

The A&E Awning is designed and intended for use on Motorhomes, Travel Trailers, and Fifth Wheels with straight sides.

Important: Structural backing is required where mounting screws/oscar rivets will be installed through side wall for securing top mounting brackets and back channels.

Important: Follow the Minimum distance dimensions requirements from awning rail to door. Mounting height depends on awning type and length. Insure sufficient room is available before starting installation. If a slide out room is under the canopy, contact your Dometic Sales Representative.

Hardware Model	Metal Weather Shield
8551101.40(X)(X)	12"
8551102.40(X)(X)	7"
8551103.40(X)(X)	12"
8551104.40(X)(X)	7"

When the door falls in the center of the awning, add 2" to these distances.

Installation Height: This is the center to center distance of mounting holes in the top mounting bracket and the back channel. See Specification Chart and illustrations on page 3 & 4.

Dometic Corporation reserves the right to modify appearances and specifications without notice.

Specification Chart			
8551101.40(X)(X)	8551102.40(X)(X)	8551103.40(X)(X)	8551104.40(X)(X)
A 66"	69-1/2"	63-3/4"	67-1/4"
B 62-1/64"	65-3/8"	59-13/16"	63-11/64"
C 62-33/64"	65-7/8"	60-37/64"	63-15/16"
D 1/2"	1/2"	3/4"	3/4"
E 64-1/4"	67-3/4"	62"	65-1/2"
F 62"	65-1/2"	62"	65-1/2"
G 1-1/64"	1-5/32"	1-1/64"	1-5/32"
H 1-3/4"	1-3/4"	1-3/4"	1-3/4"
J 5/8"	5/8"	13/32"	13/32"

- A= Overall length of hardware.
- B= Minimum mounting distance center to center on mounting holes.
- C= Maximum mounting distance center to center on mounting holes.
- D= Distance between mounting holes in bracket.
- E= Location of hole for wire harness.
- F= Back channel length.
- G= Distance between bottom of back channel and center of mounting hole.
- H= Distance front channel cover extends past back channel.
- J= Distance from top edge of top bracket and center of the upper mounting hole.

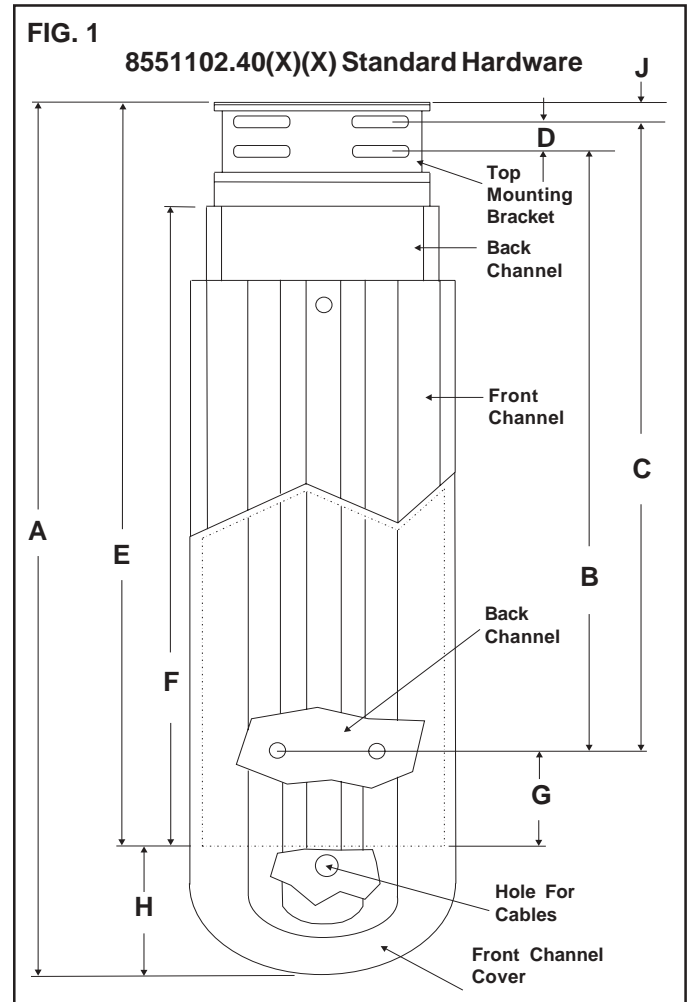

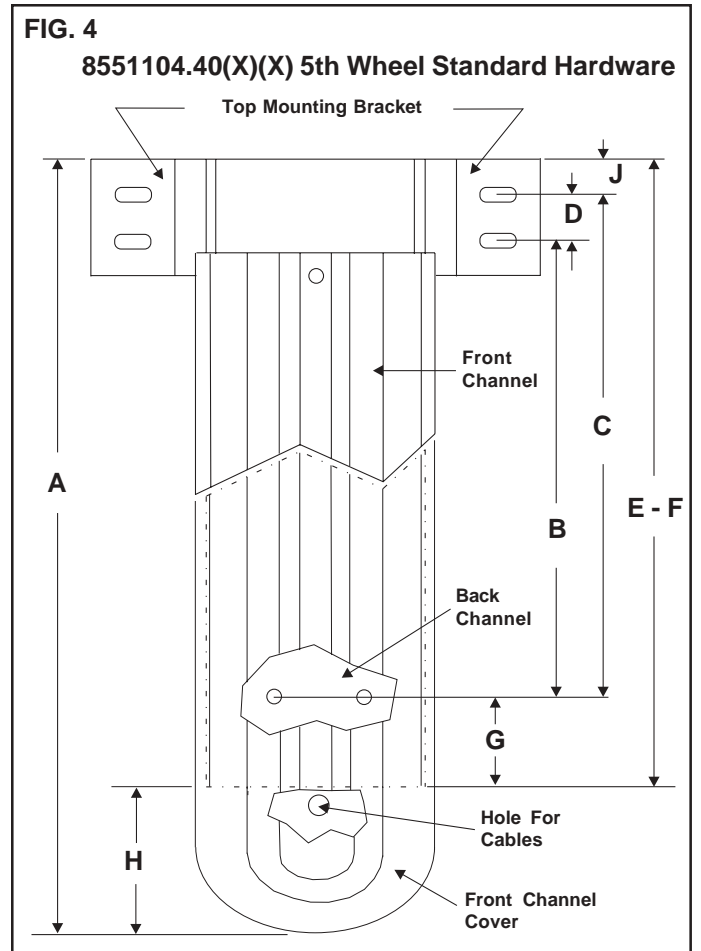
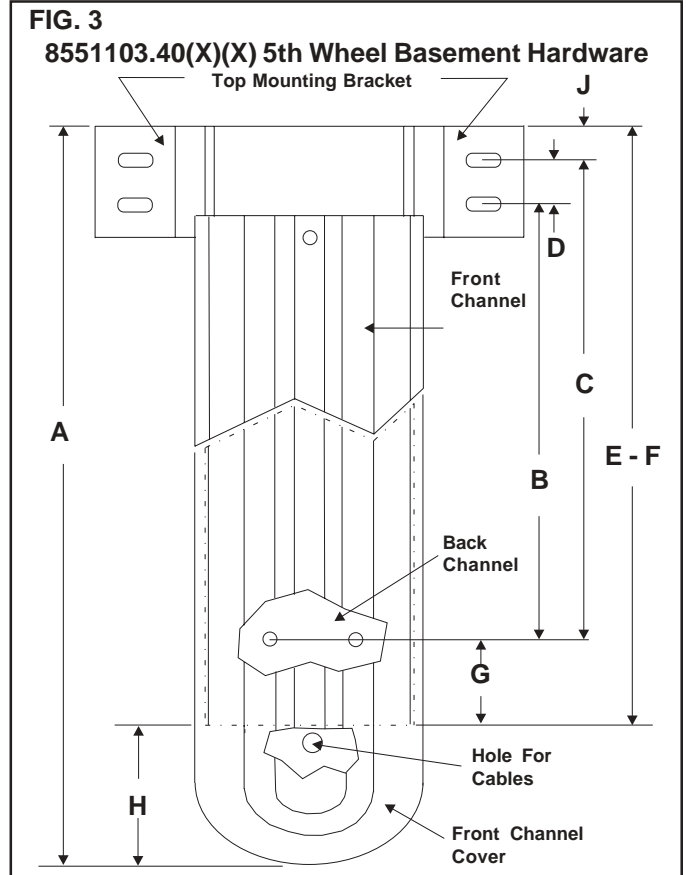
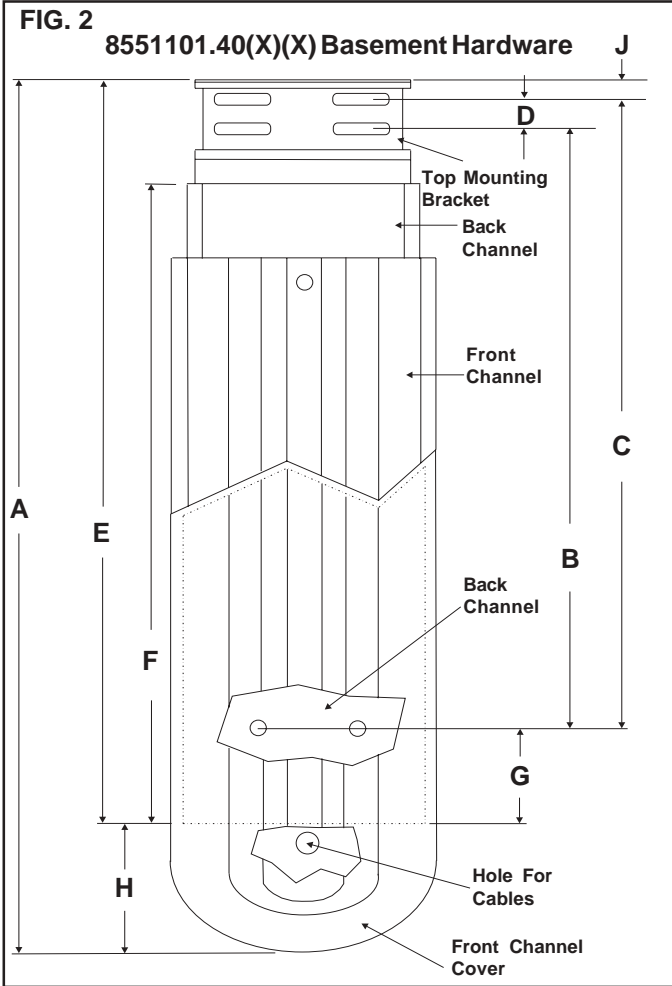

INSTALLATION INSTRUCTIONS

Installation of A&E Awnings will briefly require three people. Use the following procedure to assure a properly installed, and properly functioning awning.

A. Secure FRTA to Hardware

- Carefully lay the fabric roller tube assembly on a clean, well padded "V" trough to prevent fabric and/or roller cover damage. Remove the hardware from the packaging and place the arm pre-wired for the motor on the right side. The left arm has a spring loaded bottom arm and is not pre-wired for the motor.

⚠ WARNING

Personal Injury hazard. Do not remove the cotter pin located on the left side of the FRTA until instructed to do so. The FRTA is pre-wound and under tension. Rapid spin-off will occur if the cotter pin is removed. Failure to follow these instructions could cause serious personal injury or property damage.

⚠ WARNING

Personal injury hazard. Do not remove the nylon ties until instructed to do so. The gas shocks on the hardware arm assemblies are pressurized and will spring open if not controlled. Failure to follow these instructions could cause serious personal injury or property damage.

- Secure each front channel to top casting of the FRTA. See FIG. 5. Slide top nylon ties down arm approximately 24 inches from top of front channel to allow hardware to open far enough to insert top casting into front channel. Do Not remove nylon ties at this time. The gas shocks on arm assemblies are pressurized and will spring open if not controlled.

Note: One hardware arm assembly is pre-wired for awning motor. This arm goes on the right side of the FRTA.

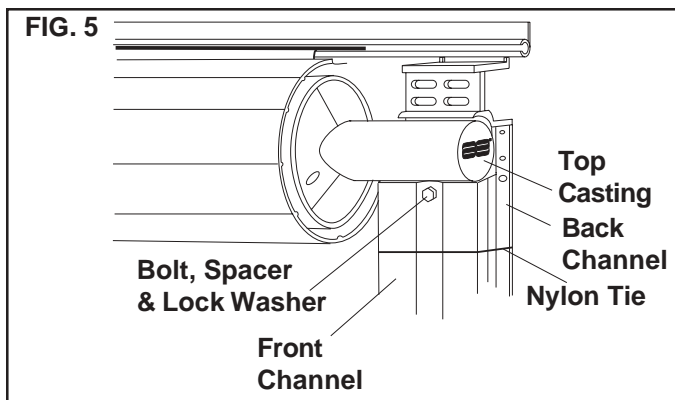

Note: One hardware arm assembly has a spring loaded bottom arm. This arm goes on the left side of FRTA. See FIG. 6.

- Using one (1) 1/4"-20 x 3/4" hex head bolt, one (1) spacer and one (1) 0.25 split lock washer secure the

left side top casting to the left side channel. See FIG. 5. The right side is secured with one (1) 1/4"-20 x 1-1/4" hex head bolt, one (1) spacer and one (1) 0.25 split lock washer.

- Remove cotter pin from left side end cap.

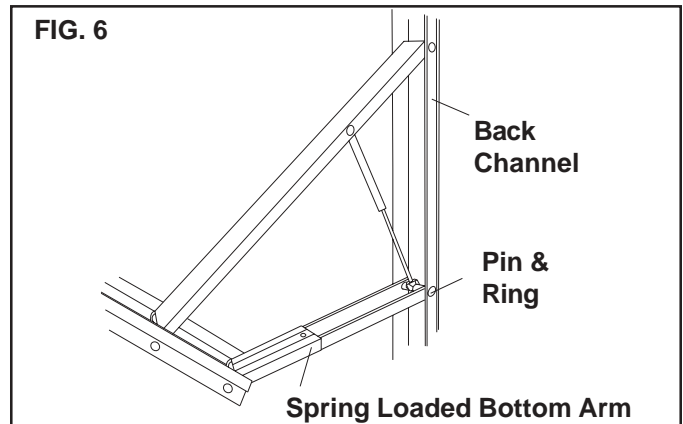

⚠ WARNING

Personal injury hazard. Do not attempt to separate the FRTA from the hardware arm unless the torsion assembly is re-pinned. The FRTA is pre-wound and under tension. Rapid spin-off will occur if separated. Failure to follow these instructions could cause serious personal injury or property damage.

B. Install Fabric in Awning Rail

- Prepare the awning rail to accept the awning fabric.
 - Select the end from which the awning shall be fed, then widen that end with a flat screwdriver and file off any sharp edges. See FIG. 7A.

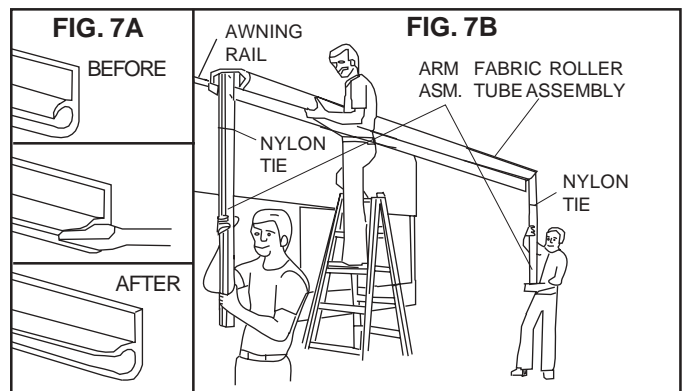

- Unwind fabric one revolution before feeding awning fabric into awning rail. This will allow enough space between side wall and awning hardware to connect wires in Step C-1-c.
- With one person grasping each arm assembly, carefully lift the entire assembly to an upright position.

Important: Keep the two arm assemblies parallel to each other to avoid excessive twisting and possible damage to the assembly.

4. Walk the awning to the end where the awning rail was prepared. A third person is now required to feed the fabric into the awning rail. The other two will walk the entire awning assembly forward and into the desired position. See FIG. 7B.

C. Top Mounting Bracket Installation

1. (8551101 Basement & 8551102 Standard Hardware) Secure Top Mounting Brackets.
 - a. After the complete awning assembly has been threaded into the awning rail, check that its position allows for solid mounting of the top mounting brackets and the back channels. Also insure that the back channels are in the desired location (not restricting use of doors, access doors, windows, etc.).

Important: Structural backing is required where mounting screws will be installed through side wall for securing top mounting brackets.

Note: Awning rails with rain gutters may not allow the FRTA to close all the way. It may be necessary to lower the top bracket position to ensure the FRTA will close properly. See FIG. 8B.

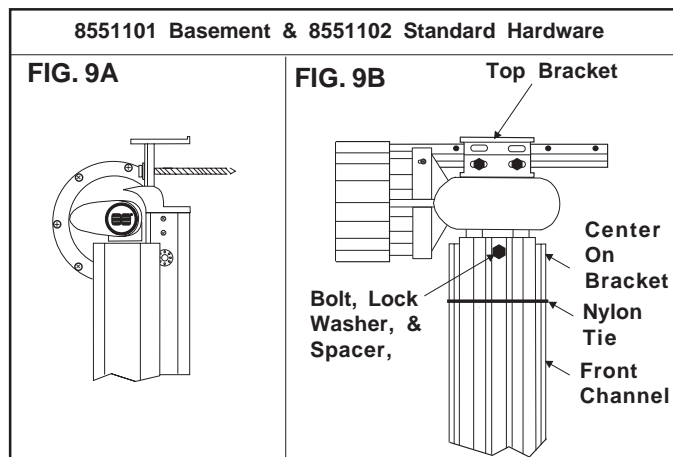
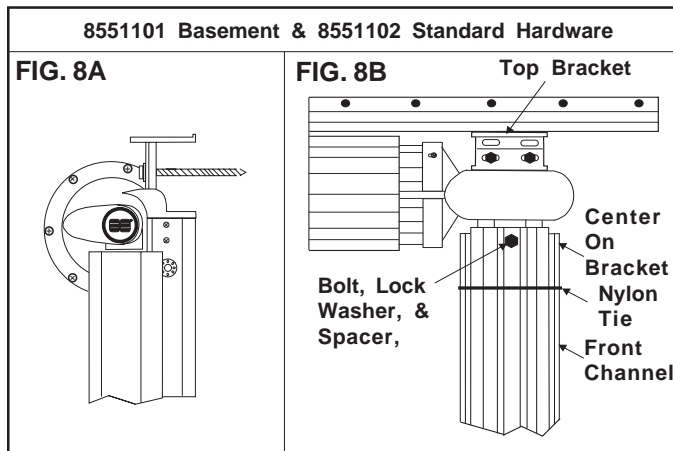

Note: Awning rails with rain gutters may require a spacer kit to prevent the FRTA from closing against the rain gutter, causing fabric damage and/or improper operation. These 3308059.XXX(X) and 3309390.XXX(X) back channel spacer kits can be obtained through Dometic.

- b. Place both top brackets in position over or directly under the awning rail as shown in FIG. 8B & 9B. The motorized arm assembly is always installed on the right side of the awning. Top mounting bracket must be installed parallel with awning rail. Mark the hole position for the top bracket and slide the assembly out of the way. Predrill the two holes using a 3/16" drill bit (use a 7/32" drill bit if in steel). Install top bracket with two (2) #14-10 x 2-3/4" hex head screws. Seal where the screws enter the coach with clear silicon sealer. At this point the arm assembly can support itself. Repeat this procedure on the opposite side.

CAUTION

The arm assemblies must be controlled while the top mounting brackets are being installed. When the weight of the FRTA is no longer supported, the downward force could cause the arm assembly to swing side ways and may damage the side wall if not controlled.

- c. Motor connection
 - Remove nylon ties wrapped around front and back channels. See FIG. 5.

! WARNING

Personal injury hazard. Do not attempt to separate the FRTA from the hardware arm unless the torsion assembly is re-pinned and the arm assemblies are re-tied. The FRTA is pre-wound and under tension. Rapid spin off will occur if separated. The arm assemblies are pressurized and will spring open. Failure to follow these instructions could cause serious personal injury or property damage.

- Grasp the right side front channel and slowly pull it away from the side wall.
- Connect the factory prewired motor wire harness in the front channel to the factory pre-wired motor wire harness in the FRTA. See FIG. 10.

Important: Dielectric grease must be placed on all exposed pins.

- Next, plug the factory prewired wind sensor harness in the front channel into the wind sensor. Make sure it is pushed on all the way.

Important: Once plug has snapped into position, do not pull on plug to remove without depressing the red tab to disengage catch. Damage to the plug and/or the wind sensor could occur if not disconnected properly.

- b. Place both top brackets in position directly under the awning rail as shown in FIG. 11B. The motorized arm assembly is always installed on the right side of the awning.

Note: Awning rails with rain gutters may require a spacer kit to prevent the FRTA from closing against the rain gutter, causing fabric damage and/or improper operation. These 3308059.XXX(X) and 3309390.XXX(X) back channel spacer kits can be obtained through Dometic.

Top bracket must be installed parallel with the awning rail. Make sure arms are located in the correct position and using the outside bracket hole as a guide predrill a 3/16" hole for mounting screw. Drill a 7/32" hole if drilling into steel. Install outside top mounting bracket using one (1) #14-10 x 1-1/2" hex head screw. Seal where the screw enters the side wall with clear silicon sealer. Repeat this procedure for opposite side.

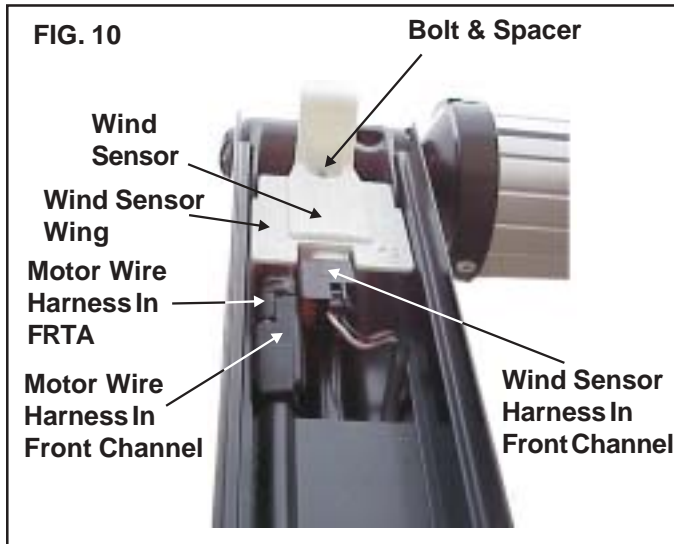

- Place wind sensor over screw protruding from back side of top casting. Tuck any excess wire from the motor harness and wind sensor harness underneath the wing of the sensor as shown. See FIG. 10.
 - Secure the wind sensor with supplied 1/4"-20 lock nut w-insert and 3/16" nylon spacer. Tighten nut until wind sensor seats against back of top casting. Do not over-tighten nut; wind sensor housing could be damaged if nut is over tightened.
2. (8551103 Basement & 8551104 Standard 5th Wheel Hardware) Secure Top Mounting Brackets.
- a. After the complete awning assembly has been threaded into the awning rail, check that its position allows for solid mounting of the top mounting brackets and the back channels. Also insure that the back channels are in the desired location (not restricting use of doors, access doors, windows, etc.).

Important: Structural backing is required where mounting screws will be installed through side wall for securing top mounting brackets.

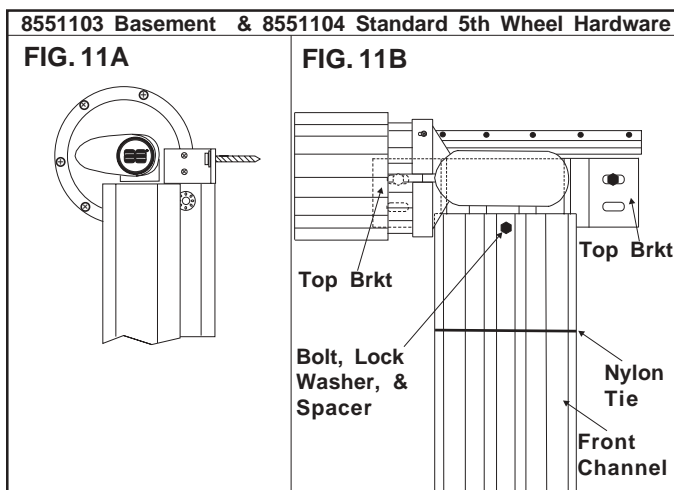

CAUTION

The arm assemblies must be controlled while the top mounting brackets are being installed. When the weight of the FRTA is no longer supported, the downward force could cause the arm assembly to swing side ways and may damage the side wall if not controlled.

- c. To install screws on the inside top mounting brackets it will be necessary to pull the FRTA away from the side wall approximately 12". Remove nylon ties wrapped around the front and back channels. See FIG. 11B. Grasp the front channel and slowly pull it away from the side wall. Again make sure arms are in the correct position and predrill hole as in previous step and install one (1) #14-10 x 1-1/2" hex head screw. Repeat this procedure for opposite side. Seal where screw enters the side wall with clear silicon sealer.

WARNING

Do not attempt to separate the FRTA from the hardware arm unless torsion assembly is re-pinned and the arm assemblies are re-tied. The FRTA is pre-wound and under tension. Rapid spin-off will occur if separated. The arm assemblies are pressurized and will spring open. Failure to follow these instructions could cause serious personal injury or property damage.

- d. Motor connection
- Connect the factory prewired motor wire harness in the front channel to the factory pre-wired motor wire harness in the FRTA. See FIG. 10.

Important: Dielectric grease must be placed on all exposed pins.

- Next, plug the factory prewired wind sensor harness in the front channel into the wind sensor. Make sure it is pushed on all the way.

Important: Once plug has snapped into position, do not pull on plug to remove without depressing the red tab to disengage catch. Damage to the plug and/or the wind sensor could occur if not disconnected properly.

- Place wind sensor over screw protruding from back side of top casting. Tuck any excess wire from the motor harness and wind sensor harness underneath the wing of the sensor as shown. See FIG. 10.
- Secure the wind sensor with supplied 1/4"-20 lock nut w/insert. Tighten nut until wind sensor seats against back of top casting. Do not over-tighten nut; wind sensor housing could be damaged if nut is over-tightened.

D. Electronic Control Kit, Awning Motor, Wind Sensor, and Remote Switch Installation.

Important: Electronic Control is also pre-wired for installing an A & E Oasis Elite awning. Unless an A & E Oasis Elite awning is being installed at the same time only connectors designated for WeatherPro will be used.

Important: The Electronic Control & Remote Key FOB are programmed as a matched set. They must remain together.

- First, decide on a location for the Electronic Control. Recommended locations for the Electronic Control are compartments outside the living quarters such as one of the basement storage compartments. The Electronic Control must be installed at a location where it will not be close to steel framing or directly exposed to weather or extreme temperatures.

Important: Make sure channel is in proper position and drill a 1-1/4" hole through side wall for harness. See FIG. 1, 2, 3 & 4.

- Connect Electronic Control to Awning Motor. See FIG. 14.
 - The installer will provide a wire harness using the proper plugs and pins or the supplied 3309726.010 Patio Motor Wire Harness, depending on the kit being installed. Connect one end of the harness to the two position cap extending from the bottom of the right side

hardware arm. Route opposite end of harness through 1-1/4" hole and connect it to the Electronic Control connector marked "**Patio Motor**". See FIG. 14. To avoid voltage drop, follow wire length guide listed in next paragraph.

Wire Length	Wire Size
10' & Under	14 Gauge
11' to 30'	12 Gauge
Over 30'	10 Gauge

Important: When routing harness, take precaution against wires rubbing on sharp edges and use a grommet (supplier installed) when going through walls. Harness should be routed so that when bottom bracket is installed it will cover hole where wire goes through wall. Seal any holes with clear silicon sealer. See FIG. 1, 2, 3 & 4.

- Connect Electronic Control To Wind Sensor. See FIG. 14.
 - The installer will provide a wire harness using the proper plugs and sockets or the supplied 3309726.036 Wind Sensor Wire Harness, depending on the kit being installed. Connect one end of the harness to the three position cap extending from bottom of the right side hardware arm. Route opposite end of harness through 1-1/4" hole and connect it to the Electronic Control connector marked "**Wind Sensor**".
- Connect Electronic Control To The Remote Switch. See FIG. 14.
 - Install the remote switch at a convenient location such as the door area.
 - The remote switch should not be in direct exposure to weather or extreme temperatures.
 - Cut hole in structure where switch is to be installed. Place decal on bezel and pop remote switch into bezel opening.
 - Route three (3) wires (installer supplied) from the Electronic Control to the remote switch. These wires should be brown, yellow and green 16 gauge wires. Install 1/4" insulated terminals on the remote switch end of wires. Connect wires to switch. See FIG. 14 for wire locations. Secure bezel with appropriate fasteners (not supplied). The Electronic Control end of wire will require a three position plug and pins (installer supplied) or supplied 3309726.044 Patio Switch Wire Harness, depending on the kit being installed. Plug this end of the harness into the Electronic Control connector marked "**Patio Switch**".

E. Connect Electronic Control To The 12 VDC Power Supply And Ignition Interlock

- Connect the Electronic Control To the 12 VDC Power Supply. See FIG. 14 for wire positions.

- a. Run two (2) wires (installer supplied) from the Electronic Control to the 12 VDC supply. It is recommended that these wires be (Red positive + and Black negative -) 12 gauge wires. This should be on a separate 15 amp circuit. The Electronic Control end of the 12 VDC supply wires will require a four position connector and sockets (installer supplied) or supplied 3309726.067 12 VDC Power Wire Harness, depending on the kit being installed.

Important: To ensure proper operation, the Electronic Control must have a minimum of 12.5 VDC at the Electronic Control during awning operation. It may be necessary to increase the wire size if voltage is below 12.5 VDC.

3. Connect Ignition Interlock Wire. See FIG. 14 for wire position.
 - a. When installed correctly the interlock connection prevents the awning from being extended when the vehicle ignition is "ON".
 - b. Run a 16 gauge wire (installer supplied) from the Ignition Isolator (+12 VDC) of vehicle to the Electronic Control. The Electronic Control end of wire will require a socket (installer supplied) or a proper size wire nut to connect it to the supplied 3309726.067 12 VDC Power Wire Harness, depending on the kit being installed. Plug this harness into the Electronic Control connector marked "**Power 12 VDC**".

Important: The awning is now operational. Do not move vehicle until steps F and G are completed.

F. Back Channel And Bottom Bracket Installation

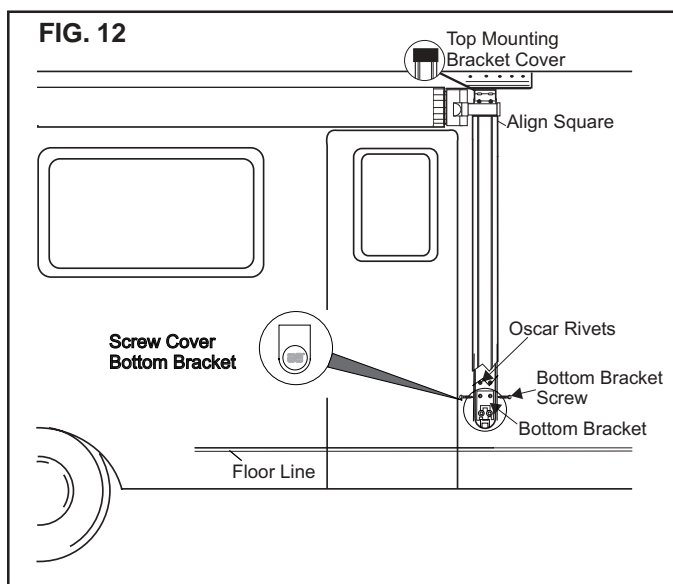

Important: Structural backing (metal) is required where oscar rivets will be installed through side wall for securing back channels.

1. Open awning as required to secure back channel and install bottom bracket.
2. Remove bottom bracket from inside back channel if installed.
3. Align the back channel so it is square with the vehicle and the FRTA. A door or window frame can be used to measure from. See FIG. 12.
4. Drill two (2) 3/16" holes through the outside wall using the holes in the bottom of back channel as a guide. See FIG. 1, 2, 3 & 4.
5. Secure back channel to wall with two (2) 3/16" x 1" Oscar rivets provided. See FIG. 12.

Important: Structural backing (metal) is required where oscar rivets will be installed through side wall for securing back channel.

6. Seal where the oscar rivets enter the vehicle with clear silicon sealer.
7. Slide bottom brackets back into position. While holding bottom bracket in position drive two (2) #10-16 x 3/4" self drilling screws through hole in back channel and into bracket. See FIG. 12.

G. Initial Awning Adjustment

1. Turn on the 12 VDC power supply and cycle the awning four or five times to check fabric alignment and to make sure the hardware is nesting properly. If there is a misalignment, adjust the arm by loosening the upper mounting bolts and move the bracket accordingly. Cycle the awning again to check the alignment. See User's Guide for opening and closing instructions.
2. When satisfied with the alignment, secure fabric roller cover by driving a # 6-20 x .44" Tek screw through the rail and into the fabric rope. See FIG. 13 for screw location. Repeat on opposite side. Snap top and bottom screw covers in position. Top screw covers are only used on 8551101 & 8551102 hardware. See FIG. 12. The installation is now complete and ready for use.

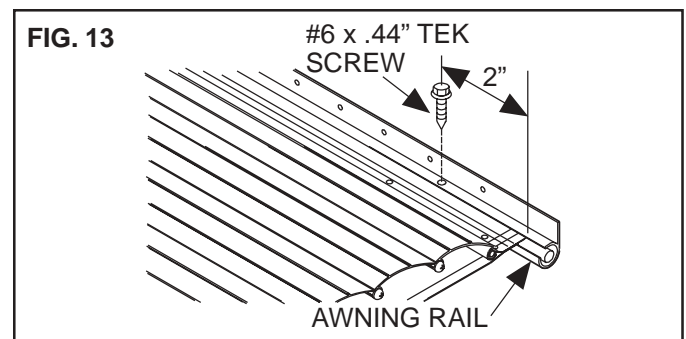

H. Close and Secure Awning

1. If awning will not be used after installation, close and secure. See User's Guide for closing and securing instructions.

FIG. 14

3309424.004 & 3309424.012 Control Kit Wiring

