

TOSHIBA

Digital Satellite System

RECEIVER OPERATION MANUAL

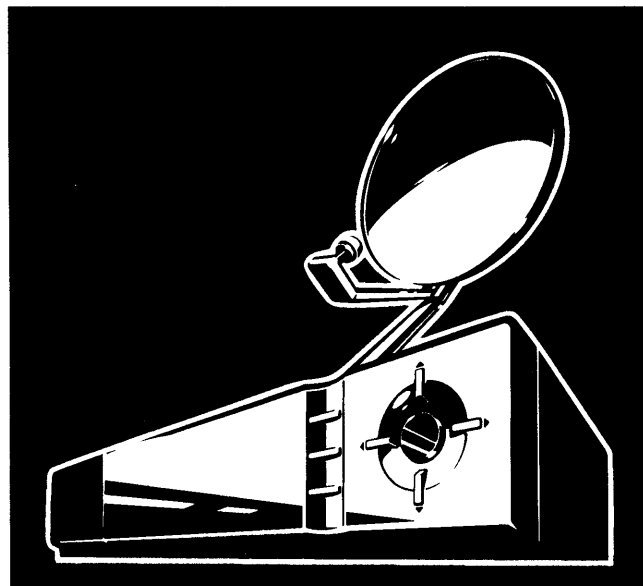

TSR-101

SAFETY INFORMATION

WARNING

To reduce risk of fire or shock hazard, do not expose this receiver to rain or moisture.

WARNING

RISK OF ELECTRIC SHOCK
DO NOT OPEN



This symbol indicates "dangerous voltage" inside the product that presents a risk of electric shock or personal injury.



This symbol indicates important instructions accompanying the product.

TO REDUCE THE RISK OF ELECTRIC SHOCK, DO NOT REMOVE COVER (OR BACK). NO USER SERVICEABLE PARTS INSIDE. REFER SERVICING TO QUALIFIED SERVICE PERSONNEL.

Cautions

Do not stack electronic components or other objects on top of the DSS® Receiver. The slots on top of the receiver must be left uncovered to allow proper airflow to the unit. Blocking the airflow to the unit could impair performance or damage your receiver and other components.

Do not stack the DSS® receiver on top of a "hot component" such as an audio power amplifier.

FCC Regulations state that unauthorized changes or modifications to this equipment may void the user's authority to operate it.

Note to Cable TV Installer:

This reminder is provided to call your attention to Article 820-40 of the National Electrical Code (Section 54 of the Canadian Electrical Code, Part 1) which provides guidelines for proper grounding and, in particular, specifies that the cable ground shall be connected to the grounding system of the building as close to the point of cable entry as practical.

Note to Satellite Dish Installer:

This reminder is provided to call your attention to Article 810 and in particular article 810-15 of the National Electrical Code which covers proper installation and grounding of television receiving equipment as well as to article 820-40 of the National Electrical Code which specifies that the satellite dish cable ground shall be connected to the grounding system of the building as close to the point of cable entry as practical.

IMPORTANT NOTICE:

This device incorporates an anticopy process technology that is protected by U.S. patents and other intellectual property rights. The anticopy process is licensed for non-commercial, home use only. Reverse engineering or disassembly is prohibited.

DSS® is a registered trademark of DIRECTV, Inc., a unit of GM Hughes Electronics Corp.

StarSight-Licensed: The manufacture and sale of the television schedule feature of this product was licensed under one or more of the following patents of StarSight Telecast, Inc.; U.S. Patent Nos. 4,706,121; 4,977,455; 5,151,789; and 5,353,121.

Table of Contents

Introduction 3-6

- DSS® System Summary 4
 - The On-Screen Navigation Method 4
 - Using the Program Guides 5
 - Using the On-Screen Menu System 5
- Installing Batteries In the Remote Control 6
- Unpacking the Box 6

Program Guides 7-12

- What is a Program Guide? 7
 - Using the GUIDE Button 7
 - Changing Channels with the Number Keys (0-9) 7
 - Scrolling Channel By Channel 7
 - Scrolling Page By Page 8
 - Tuning to a Program 8
 - Selecting A Program Guide from the Main Menu 8
 - Types of Program Guides 9
- Sorting the Grid and Info Guides 11
- Exiting A Program Guide 12

The Menu System 13-14

- Using the Menu System 13
- Menu Descriptions 14

Lists & Limits 15-20

- Controlling The System 15
 - Especially for Parents 15
 - An Overview 16
 - Setting the Rating Limit 16
 - Setting Up Spending Limits 17
- Creating Favorite Channel Lists 17
 - Add or Delete All Channels 18
 - Naming A Channel List 19
- Parent Approved Channel List 19
- Selecting a Channel List to Use 19
- Locking the System 20
 - Unlocking the System 20
 - Session Unlock 20

Introduction

Program Guides

The Menu System

Lists & Limits

More Features

Connections

Reference

Table of Contents

Introduction

Program Guides

The Menu System

Lists & Limits

More Features

Connections

Reference

More Features	21-28
Pay-Per-View Programs	21
Purchasing and Viewing	21
Tuning to a PPV Program	21
Using the Program Guide for PPV Programs	22
Using the Attractions Guide	22
Using the Purchases Menu	23
Reviewing and Canceling an Upcoming Purchase	23
Timer Feature	24
Using the Surf Feature	24
The Mailbox	24
How to Tell When You Have Mail	25
Checking Your Mail	25
Alternate Audio Programs	25
Picture Size	26
System Test	26
New Access Card Setup	26
Using On-Line Help	27
Auto Help	27
Help Buttons	27
Menu Help	27
Connections	29-36
Things to Know Before Connecting Components	29
Connecting Your Satellite Receiver to Your TV	30
Interactive Setup	36
Disabling Interactive Setup	36
Reference	37-53
Parts of the DSS® System	37
World View	37
Home View	38
Controls and Buttons	39
Front Panel Controls	39
Back Panel	40
Remote Control Buttons	41
Programming the Remote Control Using Access Codes	42
Using the 3-Digit Code Method	42
Using the Search Method	43
Remote Codes	44
Glossary	45
Troubleshooting	47
Limited Warranty	48
FCC Registration Information	52
Index	53

Congratulations! We would like to congratulate you on purchasing a Toshiba brand Digital Satellite System. DSS® will prove to be the best investment in your family's entertainment with over 200 channels of superior digital video and audio now available.

Features Galore. Your Toshiba brand DSS® is packed full of features that add to the pleasure in owning a Digital Satellite System. The TSR-101 you have purchased comes equipped with a fully backlit universal remote control that will operate your other Home Theater products such as a TV, VCR and stereo. Some of the other features of your TSR-101 include:

Direct Tuning which is a StarSight® feature that allows you to easily tune to a desired channel from the Program Guide.

Parental Lock to block out unwanted channels and set viewing rating limits.

Reserve A Program which will allow you to order pay-per-view programs in advance.

S-Video Output for improved video output to TV or VCR for superior viewing.

Programming. Once your Toshiba brand DSS® is completely installed, you must call one or both of the programmers if your dealer has not already done so.

Before you start dialing, they will ask for your Access Card number which can be found in the *Options* menu. Select *System Test* and wait for the Access Card number to be displayed. They will also ask for the serial and model number of your unit which can be found on the back of your receiver.

DirecTV, call 1-800-347-3288

USSB, call 1-800-204-USSB (1-800-204-8772)

Instruction Manual Overview. This manual is arranged in sections. Each section is devoted to a different topic. We encourage you to read the entire manual. If you have additional questions, please call our toll-free assistance line at **1-888-TOSH-DSS** (867-4377).

Introduction. This section will familiarize you with your DSS®. You will learn to navigate through the system with the use of your remote control, and Program Guides and On-Screen Menu System.

Program Guides. This section is devoted to explaining the different on-screen guides for your DSS®.

The Menu System. This section will familiarize you with each menu and give you a brief description.

Lists & Limits. Here you will learn to set rating limits, spending limits for pay-per-view (PPV), create favorite channel lists and establish parent approved channel lists.

More Features. This section addresses purchasing and canceling an upcoming PPV program, Timer Features, the Surf Feature, Mailbox functions, Alternate Audio programs, Picture Size, System Test, New Access Card Setup and On-Line Help.

Connections. Read this section very carefully. Here you will learn how to make various connections in the home in order to optimize your DSS® viewing.

Reference. Finally you will find the glossary of terms used throughout this manual as well as basic information that will help you and your family enjoy your new Toshiba brand DSS®.

Once again, if you have any questions relating to your Toshiba brand DSS®, please don't hesitate to contact us at our toll-free number, 1-888-TOSH-DSS. Thank you again for your support.

Introduction

DSS® System Summary

If you know how to watch television, then you already have the basic skills needed to use your DSS® system.

Some of the differences between regular television viewing and satellite TV are as follows:

- **On-screen Program Guide** like a TV listing in the newspaper. It is designed to help you select regular programs and pay-per-view events. You can also sort the Guide to list only specific types of programs. You can select Sports, for example, and your guide will show current and upcoming sports programs only.
- **On-screen Menu System** which allows you to customize your system. You can set up your system, build channel lists, preview coming attractions, set spending limits, and receive mail from your program providers.

The On-Screen Navigation Method

Point and Select is the method you use for navigating through the menu system and program guides. Once you know how to Point and Select, you can explore the menus to learn more about how your DSS® system works.

1. Point

You point by pressing the arrow keys on the remote or front panel. Pressing the arrow keys moves the on-screen highlight to different items in the Program Guides and the menu screens. Pressing an arrow once moves the highlight one space in the direction of the arrow.

For example, to point down (that is, to move the highlight toward the bottom of the screen), press the down arrow. To point right, press the right arrow.

2. Select

Once you have pointed to an item on the screen, select it by pressing the MENU/SELECT button on the remote or front panel. Selecting an item tells the menu system to make the change you have indicated.

For example, the instructions in the User's Manual might tell you to "Point to the *Help* button and press MENU/SELECT."

Once you understand the Point and Select method, you can use any part of the DSS® system, beginning with the Program Guides.

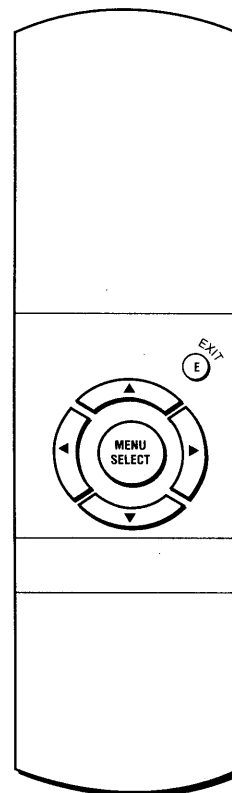

Exiting A Screen

Pressing the EXIT button on the remote takes you out of the menu system and back to the program you were watching.

Using the Program Guides

Pressing the GUIDE button on the remote control brings up the Program Guide, which looks similar to a TV listing in a newspaper. Use the arrows, the channel buttons, or the digits on the remote to highlight a channel, and then:

- Press DISPLAY to see program details.
- Press MENU/SELECT to view the program.

Note: You can only view programs for those channels to which you have subscribed.

Program Guide					Normal +12 hrs.	Mon 12/23/95 12:49 am	
12/23	6:00am	6:30am	7:00am	7:30am			
USA 101	Turtleman	Scooby-Doo	Scarey Island	Pet Central			
ESPN 102	Reboot	Animanlacs		Clarissa Tells All			
CNBC 103	Austin City Limits						
HBO 104	Clarissa Tells All		Animanlacs				
CNN 105	Reboot	Scarey Island	Austin City Limits				
MTV 106	Austin City Limits		Animanlacs				
HNN 107	Reboot	Scarey Island	Austin City Limits				
					Movies	Sports Other All Sort	

Using the On-Screen Menu System

Press MENU/SELECT to bring up the Main Menu, and then select one of the sub-menus. The following is a brief description of what each of those menus does:

Program Guide

Shows the on-screen programming schedules.

Mailbox

Use to read mail messages sent by your program provider(s).

Purchases

Use to review or cancel upcoming purchases, and to review past purchases.

Timers

Allows you to schedule the satellite system to tune to a specific channel at a specific time.

Lists & Limits

Allows you to set rating and spending limits, and to create favorite channel lists.

Options

Allows you to run the system test or to install a new access card.

Dish Pointing

Use to find your dish pointing coordinates, and to access the on-screen signal strength meter.

Assistance

Shows you information about using the system and setting the system to your personal preferences.

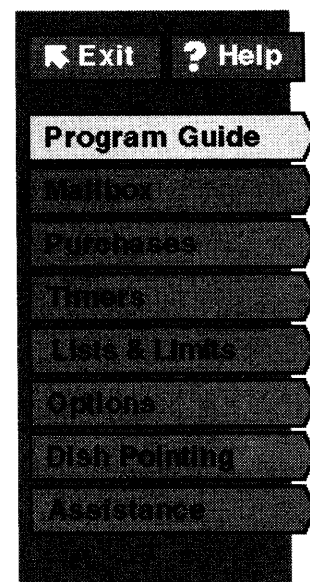

Introduction

Unpacking the Box

The following items come with your DSS® receiver:

- Receiver (access card inserted)
- Telephone Line Cord
- Remote Control
- Audio/Video Cables
- Coaxial (RF) Cable

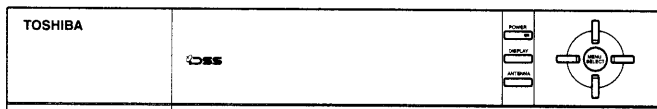

Receiver

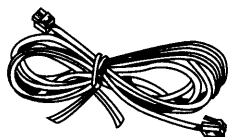

Telephone Line Cord

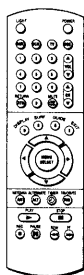

Remote Control

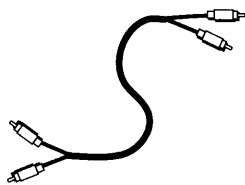

Audio/Video Cables

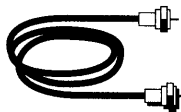

Coaxial (RF) Cable

Installing Batteries In the Remote Control

Follow these steps whenever you need to install or change the batteries in the remote control.

1. Remove the cover of the battery compartment.
2. Place batteries as shown inside the battery compartment, matching the + and - end of each battery.
3. Replace the cover.

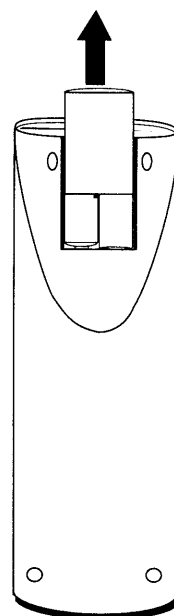

Program Guides

What is a Program Guide?

A program guide is an on-screen programming schedule. There are several types of guides, each presenting the schedule in a different format.

Using the GUIDE Button

With the remote in DSS® mode, you can access the program guides by using the GUIDE button on the remote, or by selecting *Program Guide* from the Main menu.

Each press of the GUIDE button takes you to an alternate type of program guide:

- Press GUIDE once to see the seven-channel Grid Guide.
- Press GUIDE again to see the five-channel Info Guide which contains program information.



To switch the order in which the Grid Guide and the Info Guide appear, select *Preferences* from the *Assistance* menu, and then use the arrow keys to set the *Default Guide* option.

Changing Channels with the Number Keys (0-9)

You can point quickly to any channel in the Program Guide by entering the channel number with the number keys (0-9). For example, to point to channel 128, press the numbers 1-2-8 on the remote. To point to Channel 102, press 1-0-2.

Scrolling Channel By Channel

The programs that you see on the TV screen make up one section—or page—of the total Program Guide. You can scroll to other sections using the arrows:

- Point to other times with the left and right arrows: 
- Point to other channels with the up and down arrows: 

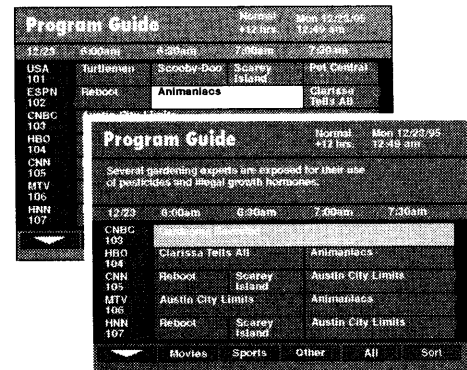

Program Guides

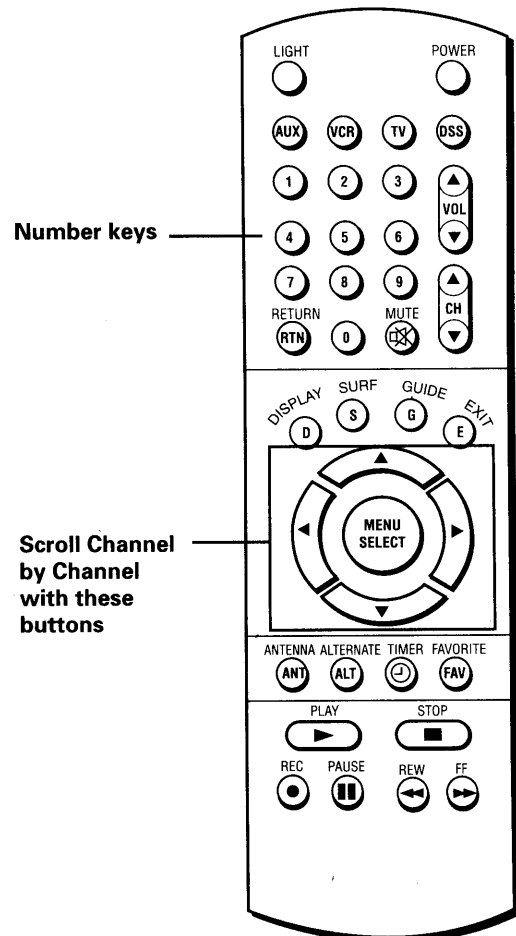

Scrolling Page By Page

If you want to scroll up or down through the Program Guide more quickly, press the Channel Up/Down buttons on the remote control. The highlight scrolls a page at a time. This is called "paging."

Tuning to a Program

- To tune to a program listed in the guide, point to the program and press MENU/SELECT.
- To see information about a program in the guide, press DISPLAY. Then, you can select *View Channel* to tune to that channel.

If you select a future program, you are given program details. If you choose a pay-per-view event, a second screen allows you to buy the program, find out more information, or return to the guide.

Selecting A Program Guide from the Main Menu

When you access the program guides through the Main menu, you have more available options:

1. Press MENU/SELECT to bring up the Main menu.
2. Point to *Program Guide* and press MENU/SELECT.

The Program Guides menu screen appears.

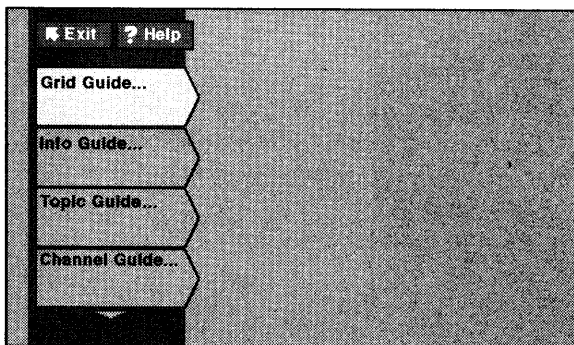

This is the Program Guides menu. Use the arrow to scroll down to see the Attractions Guide option.

If you select a future program, you are given program details. If you choose a pay-per-view event, a second screen allows you to purchase the program, find out more information, or return to the Guide.

Types of Program Guides

There are five types of program guides: the Grid Guide, the Info Guide, the Topic Guide, the Channel Guide, and the Attractions Guide.

The Grid Guide

Shows the schedule in a time-and-channel format, similar to a TV schedule listed in a newspaper.

Program Guide		Normal	Mon 12/23/95
		+12 hrs.	12:49 am
12/23	6:00am	6:30am	7:00am
USA 101	Turtleman	Scooby-Doo	Scarey Island
ESPN 102	Reboot	Animaniacs	Clarissa Tells All
CNBC 103	Austin City Limits		
HBO 104	Clarissa Tells All	Animaniacs	
CNN 105	Reboot	Scarey Island	Austin City Limits
MTV 106	Austin City Limits		Animaniacs
HNN 107	Reboot	Scarey Island	Austin City Limits
<input type="button" value="▼"/> <input type="button" value="Movies"/> <input type="button" value="Sports"/> <input type="button" value="Other"/> <input type="button" value="All"/> <input type="button" value="Sort"/>			

A straight line indicates that the program ends at this time; the straight line at the beginning of the listing indicates that the program starts at that time.

A squiggly line indicates that the current program continues; if the squiggly line is at the beginning of the listing, the program is in progress.

The seven-channel Grid Guide.

The Info Guide

Shows you five channels and includes a brief description of the selected program.

Program Guide		Normal	Mon 12/23/95
		+12 hrs.	12:49 am
12/23	6:00am	6:30am	7:00am
Several gardening experts are exposed for their use of pesticides and illegal growth hormones.			
CNBC 103	Gardening Revealed		
HBO 104	Clarissa Tells All	Animaniacs	
CNN 105	Reboot	Scarey Island	Austin City Limits
MTV 106	Austin City Limits		Animaniacs
HNN 107	Reboot	Scarey Island	Austin City Limits
<input type="button" value="▼"/> <input type="button" value="Movies"/> <input type="button" value="Sports"/> <input type="button" value="Other"/> <input type="button" value="All"/> <input type="button" value="Sort"/>			

The five-channel Info Guide gives you a brief program description.

By default, the Grid Guide appears when you press the GUIDE button on the remote. Go to the Preferences menu (located within the Assistance Menu) to change the default guide from the Grid Guide to the Info Guide.

Program Guides

The Topic Guide

This guide lets you sort the programming schedule to show certain topics, such as "movies" or "sports."

Program Guides

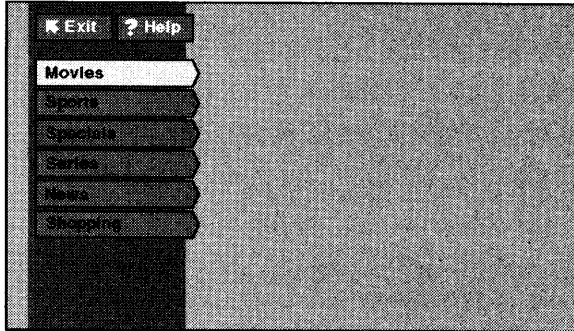

The Topic guide.

The Channel Guide

Displays the programming schedule for the selected channel.

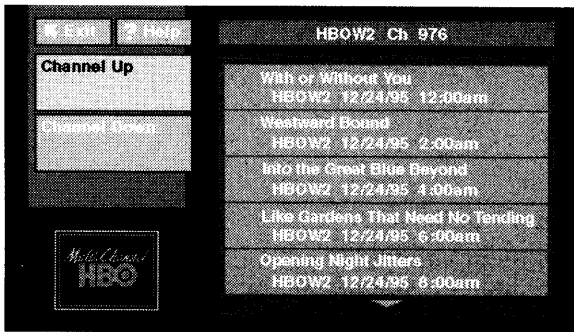

The Channel guide.

The Attractions Guide

Displays coming attractions and special events information.

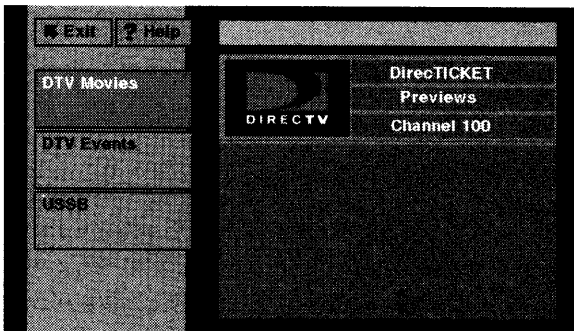

The Attractions guide.

See the section on purchasing pay-per-view programs for more information on the Attractions guide.

Sorting the Grid and Info Guides

There are six on-screen choices—called “buttons”— at the bottom of the Grid Guide and the Info Guide: down arrow, Movies, Sports, Other, All, and Sort.

Program Guide					Normal +12 hrs.	Mon 12/23/95 12:49 am
12/23	6:00am	6:30am	7:00am	7:30am		
USA 101	Turtleman	Scooby-Doo	Scarey Island	Pet Central		
ESPN 102	Reboot	Animanlacs		Clarissa Tells All		
CNBC 103	Austin City Limits					
HBO 104	Clarissa Tells All		Animaniacs			
CNN 105	Reboot	Scarey Island	Austin City Limits			
MTV 106	Austin City Limits		Animaniacs			
HNN 107	Reboot	Scarey Island	Austin City Limits			
		Movies	Sports	Other	All	Sort

The Sorting buttons are at the bottom of the screen.



The arrow button allows you to scroll down through other channels in the guide. Point to the down arrow, and then press MENU/SELECT to scroll down through the program guide.

Using the Sorting Buttons

The remaining buttons at the bottom of the guide are called “sorting buttons.” These buttons allow you to simplify the guide to show specific types of information such as movies, or sports.

Movies

The Movies button lists movies only.

After selecting Movies, point to the *Theme* button that appears and press MENU/SELECT to sort the guide to list specific types of movies, such as comedies or thrillers.

TIP

You don't have to use the on-screen Down Arrow button to scroll through the Program Guide. You can use the Arrow Buttons on the remote.

Sports

The Sports button lists sporting events only.

After selecting Sports, point to the *Theme* button that appears and press MENU/SELECT to sort the guide to highlight specific types of sports, such as basketball or soccer.

Other

Allows you choose from a list of sorting topics.

Once you have selected a sorting topic from the list, your guide will be simplified to show only that type of program.

After selecting a topic, a *Themes* button may appear in the place of the *Other* button.

All

Resets the guide to show all available channels and listings.

Sort

Takes you to the guide filter screen.

Using the Themes Button

After you select one of the sorting buttons, the name of that button changes into the *Themes* button. Use the *Themes* button to further sort the Grid or Info Guide to show subtopics ("themes"). For example, you could simplify the guide to show "baseball" under the Sports sorting button, or "comedies" under Movies.

Exiting A Program Guide

There are two ways to exit a Program Guide:

- Point to a channel and press MENU/SELECT.
- Press EXIT on the remote.

The Menu System

Using the Menu System

To bring up the Main Menu, press MENU/SELECT on the remote or front panel.

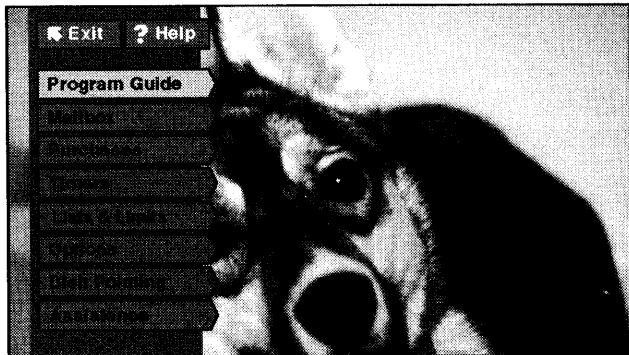

The Main Menu.

To use the menu system, you need to know the point and select method. Use the arrows on the remote to point to an item on the screen, and then press MENU/SELECT to select it.

Exit and Help

There are Exit and Help buttons at the top of most screens. Point to *Exit* and press MENU/SELECT to leave that screen. Point to *Help* and press MENU/SELECT to see more information about that screen.

Exiting a Screen

There are two ways to exit a menu:

- Point to *Exit* and press MENU/SELECT.
- Press the EXIT button on the remote control to go from the menu system to satellite TV viewing.

Using Help

All menus have a Help button which gives you helpful information explaining one aspect of that menu.

Context-Sensitive Help

Most of the screens contain information to help you to decide what to do next. If you are not sure what button to press, look for the context-sensitive help (usually at the bottom of the screen).

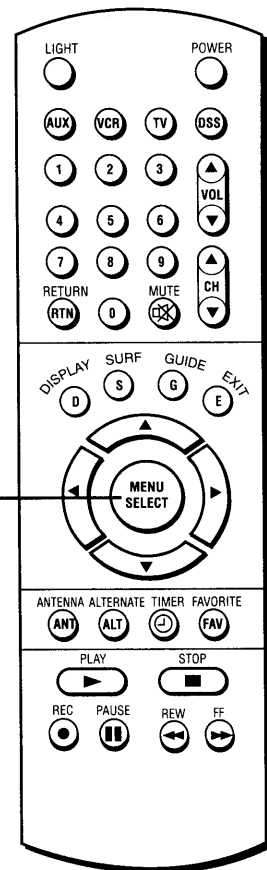

MENU/SELECT button

The Menu System

Main Menu Won't Appear?

If the Main Menu doesn't appear when you press MENU/SELECT, the remote might not be in DSS® mode. Try pressing the DSS button on the remote, and then MENU/SELECT.

Menu Descriptions

This section briefly describes each of the available Main Menu options. Detailed information about each menu is included in the sections of the manual which describe each menu.

Program Guide

Shows the on-screen programming schedules.

Mailbox

Use to read mail messages sent by your program provider(s).

Purchases

Use to review or cancel upcoming purchases, and to review past purchases.

Timers

Allows you to schedule the satellite system to tune to a specific channel at a specific time.

Lists & Limits

Allows you to set rating and spending limits, and to create favorite channel lists.

Options

Allows you to run the system test or to install a new access card.

Dish Pointing

Use to find your dish pointing coordinates, and to access the on-screen signal strength meter.

Assistance

Shows you information about using the system and setting the system to your personal preferences.

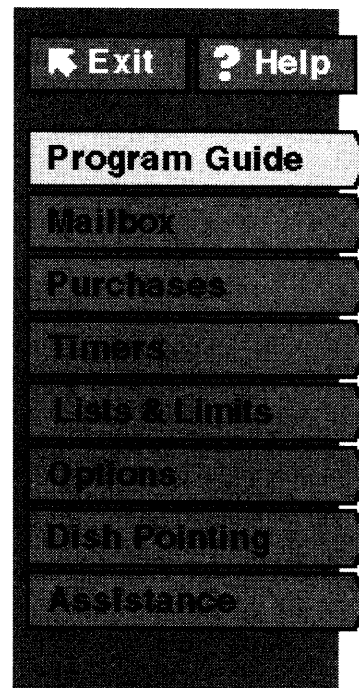

Explore the System

The best way to learn about your new satellite receiver is to use it, so don't be afraid to explore the menu system. The context-sensitive help at the bottom of the screen provides instructions for getting through any particular menu or control panel.

Remember, press EXIT at any time to leave the menu system and return to regular satellite TV viewing.

Don't Forget about the EXIT Button

Press the EXIT button on the remote to remove the on-screen menus and return to satellite TV viewing.

Lists & Limits

Controlling The System

The Lists & Limits feature puts you in control of your DSS® viewing by letting you create channel lists and set ratings and spending limits which can be password protected.

Especially for Parents

You can set up a parent approved channel list so that selected channels cannot be viewed when the system is locked, unless the system password is entered.

In addition to activating the ratings, spending, and channel limits, the system lock feature keeps anyone from changing any of the limits without first entering a four-digit password.

An Overview

When you select *Lists & Limits* from the Main Menu, the first screen you see is the Rating Limit screen. By moving down through the other options, you can set per-event spending limits, create favorite channels lists, and also lock the system by assigning a password.

Setting the Rating Limit

The Rating Limit menu enables you to set a maximum viewing limit for rated movies (based on the MPAA ratings system), as long as the program provider has transmitted the proper code.

- Note that the ratings limit cannot be enforced if a program has not been rated, if rating information for that program is not transmitted by the program provider, or if the system has not been locked.
1. Point to *Rating Limit* and press MENU/SELECT.

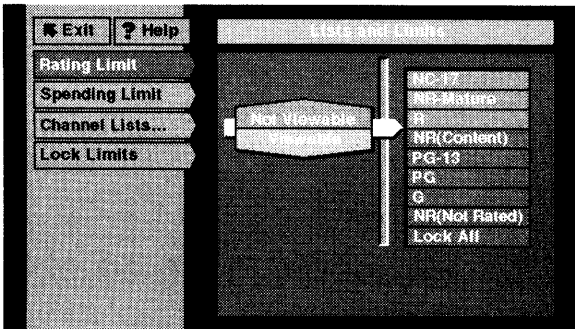

Use the arrow keys to move the selector up and down.

2. Use the up and down arrows to move the rating selector to the highest rating you want to be able to view; then press the left arrow to set the rating. (In the preceding illustration, movies that are rated up to and including an "R" rating can be viewed.)

After the rating limit is set *and* the system is locked, you must enter the system password to watch programs with a rating higher than your limit.

You need to lock the system in order for rating limits and channel lists to go into effect. See "Locking the System" for details

Setting Up Spending Limits

Use the *Spending Limit* option to indicate a per-event spending limit for pay-per-view programs.

1. Point to *Spending Limit*, and press MENU/SELECT.

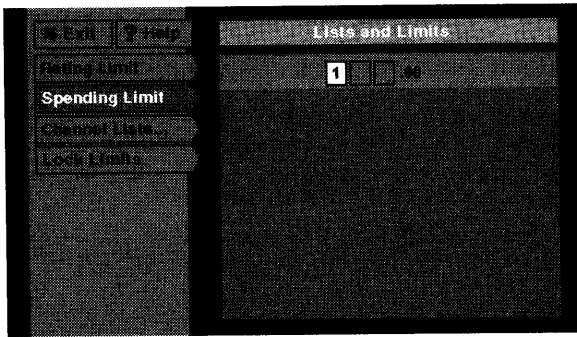

Set a per-event spending limit.

2. Use the arrow keys to enter a single-event spending limit.
After a spending limit is set *and* the system is locked, you must enter the system password to purchase a pay-per-view program that costs more than your spending limit allows.

Creating Favorite Channel Lists

You can create as many as four different channel lists that can be easily accessed by using the FAV button on the remote control.

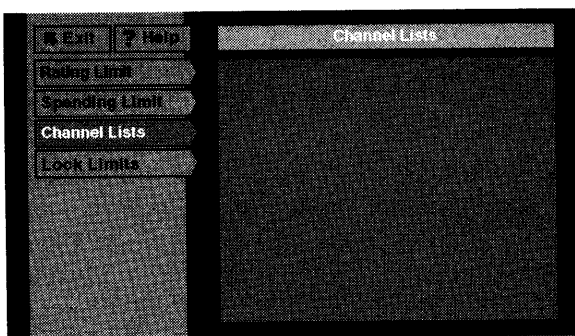

Select the Channel Lists option to create or edit a favorite channels list.

Lists & Limits

1. Point to *Channel Lists* and press MENU/SELECT.

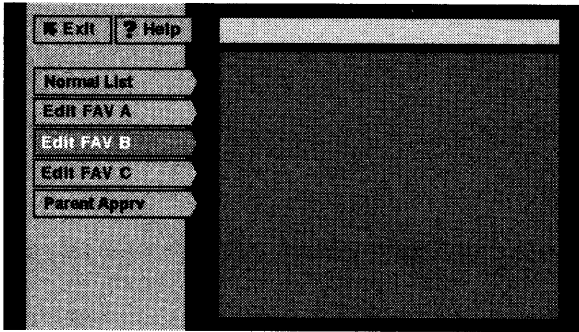

Select a Favorite channel list to edit.

2. Point to a channel list option and press MENU/SELECT.

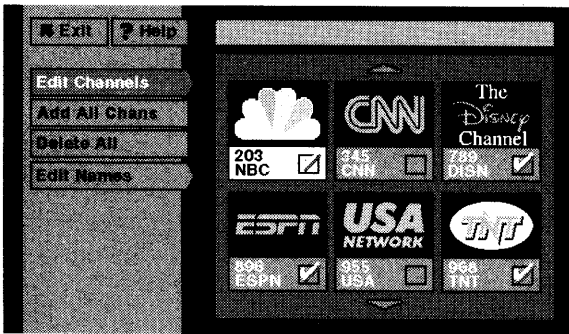

Channels containing a checkmark are included in the channel list .

3. Use the arrow keys to point to a channel, and press MENU/SELECT to remove (or replace) the check mark.

After you have set up the channel lists and locked the system, you will need to enter the system password before you can modify the existing channel lists.

Add or Delete All Channels

You might be able to save time when creating a channel list by using the *Add All Chans* option or the *Delete All* option to either add all channels or delete all channels before removing or adding individual channels.

Naming A Channel List

You can also assign a different name to each of the favorite channel lists to personalize those lists even further.

To name or edit the name of a channel list:

1. Select one of the Favorite channel lists (FAV A, FAV B, or FAV C).

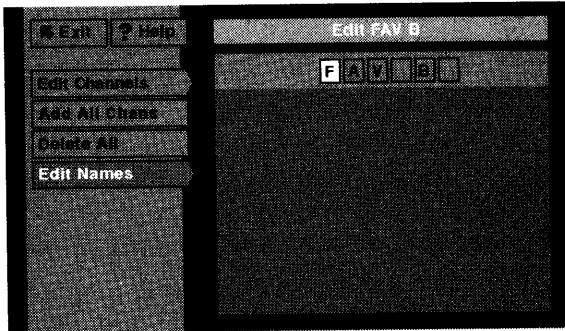

Enter a name to personalize the favorite list.

2. Point to *Edit Names* and press MENU/SELECT.
3. Use the arrows and the MENU/SELECT button to enter a name (up to 6 characters).

Parent Approved Channel List

The *Parent Apprv* channel list enables you to limit access to channels by creating a list of acceptable channels, and then locking the system.

When the system is locked, the *Parent Apprv* list overrides all other channel lists, and requires that you enter the four-digit system password to view an unapproved channel.

Note that when you enter the system password to view an unapproved channel, all spending, ratings, and channel limits remain unlocked until you turn off the receiver (see "Locking the System" for more information).

Selecting a Channel List to Use

When you turn on the satellite receiver, the unit defaults to the "Normal" channel list. You can easily change the channel list by pressing the FAV button on the remote to scroll through the available channel lists. The active channel list is indicated in the channel banner at the top of the screen (which appears when you change channels or press DISPLAY on the remote).

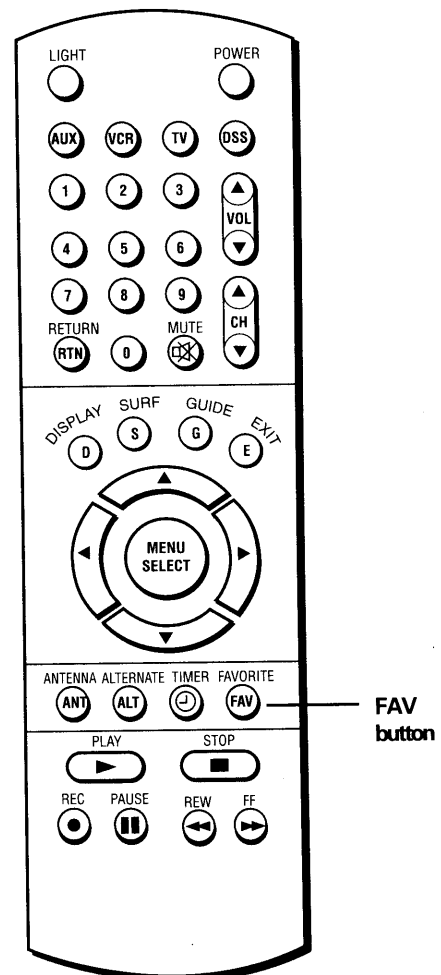

Lists & Limits

Locking the System

You can lock the system in order to put into effect the ratings, spending, and channel limits you have set up. In addition, when you lock the system, no one can modify any of these settings without first entering the four-digit system password.

1. Point to *Lock Limits* and press MENU/SELECT.

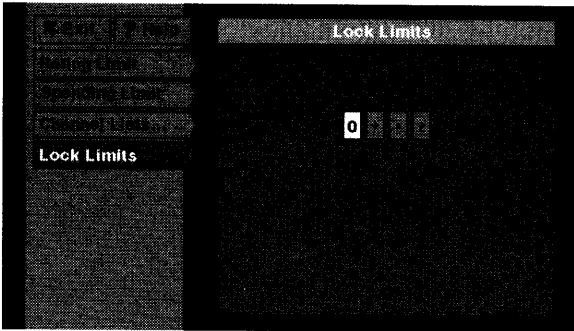

Enter a four-digit system password to lock the system.

2. Use the arrows or the digit keys to enter a four-digit system password.
3. Enter the password a second time to confirm it.

After the system has been locked, you must enter the correct password in order to access the *Lists & Limits* menu, so **Don't Forget Your Password!** If you do forget your password, contact your program provider's authorization center.

Unlocking the System

When the system is unlocked, the spending and ratings limits, that you have set are no longer in effect.

1. Point to *Unlock Limits* and press MENU/SELECT.
2. Point to *Yes* and press MENU/SELECT to confirm that you want to unlock the system.

Session Unlock (Temporary Unlock)

If your system is locked and you attempt to access a channel or program that is blocked by one or more limits, you are asked to enter the four-digit system password to override the system lock. If you enter the password to override the rating or spending limit, all limits are unlocked until you turn off the receiver. When you turn on the receiver again, the system will be locked, and the normal channel list will be selected.

Forget Your System Password?

You need to contact your program provider's authorization center to reset your system if you forget your system password.

More Features

Pay-Per-View Programs

A pay-per-view program (PPV) is a program that you purchase—like a movie ticket—on an event-by-event basis. For instance, you might be able to preview a movie, and then after previewing it, you can purchase the movie.

Purchasing and Viewing

There are several ways to purchase PPV movies and events:

- Tune to a PPV program by using the channel buttons on the remote to scan through the channel lists.
- Select a PPV program from the Program Guide.
- Select a coming attraction from the Attractions menu.

Tuning to a PPV Program

When you use the channel buttons or digits on the remote to tune to a Pay-Per-View channel, you need to press the DISPLAY button to bring up the Program Details screen in order to purchase a program.

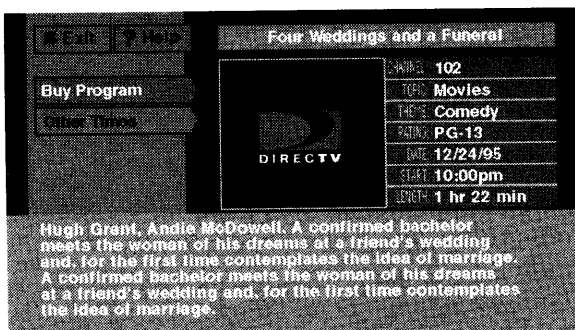

Program Details screen.

Follow the on-screen instructions to purchase the selected program.

You may need to enter your four-digit system password to order a PPV program if it costs more than the spending limit you set up in the Lists & Limits menu.

Using the Program Guide for PPV Programs

If you highlight a PPV program in the Program Guide and then press DISPLAY on the remote control, you see a program details screen similar to the following:

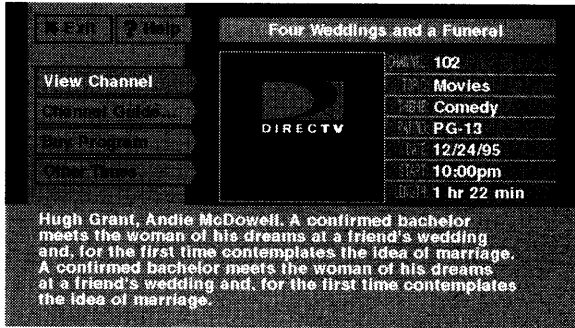

Use the Program Guide to get to the PPV Program Details screen.

- Select *View Channel* to go to that channel and view a program preview (if a preview is available).
- Select *Channel Guide* to go to the channel guide.
- Select *Buy Program* to purchase the program.
- Select *Other Times* to see additional show times.

Using the Attractions Guide

Your program providers may offer future programming events not currently listed in your Program Guide. These events are called "coming attractions," and can be previewed and purchased through the Attractions Guide.

Use Point and Select to go to the *Attractions Guide* (located within the Program Guide menu).

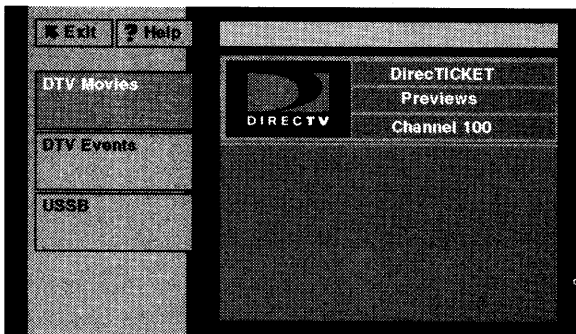

The Attractions Guide is accessed through the Program Guide menu.

Buy and Record Option

Your program provider may offer PPV programs that are coded so that you cannot record them. When these programs are offered, an additional option (*Buy and Record*) appears in the program details screen. Selecting *Buy and Record* allows you to record the program; selecting *Buy Program* allows you only to watch the program.

You need to connect your phone line to your satellite receiver to be able to order PPV programs by using the on-screen menus.

Using the Purchases Menu

The Purchases menu allows you to review upcoming and past purchases.

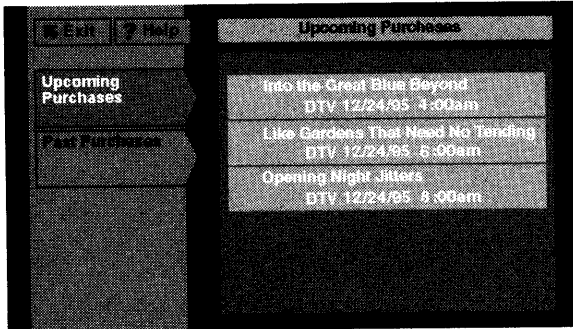

The Purchases menu shows you upcoming or past purchases.

The list of purchases may be longer than one screen; use the down arrow keys to see more items. The display also shows the title, channel, date, time, and cost of each program.

- Note that the Past Purchases list might be modified after each billing cycle and still show purchases for which you have already paid.

Reviewing and Canceling an Upcoming Purchase

Use Point and Select to choose an upcoming purchase and review the program description. From the Purchase Edit screen, you can also cancel an upcoming purchase.

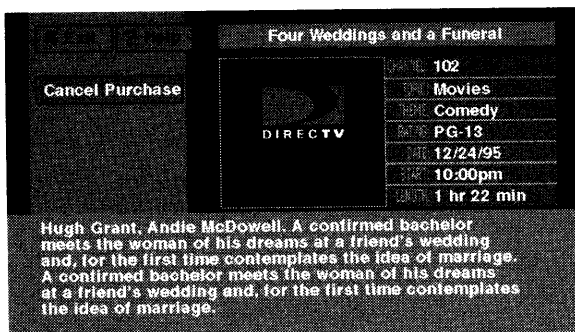

The Purchase Edit screen lets you cancel an upcoming purchase.

Timer Feature

The Timer feature allows you to preset your system to automatically tune to a particular channel at a predetermined time

To use the Timer feature, select *Timers* from the main menu to bring up the Timers screen. Select a Timer (1, 2, 3, or 4) and then use the arrow keys to complete the on-screen sentence. When the sentence is complete, select *Run Timer*.

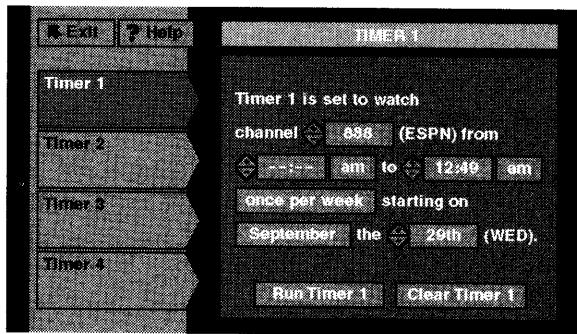

Complete the sentence to set up the selected timer.

Using the Surf Feature

Press the SURF button on the remote to bring up the current channel list in channel logo format. Then use point and select to choose a channel from the logo list.



Use Surf to see a logo-based channel list.

The Mailbox

The mailbox shows you messages that are sent—or “mailed”—from your program providers. For example, you may receive a message calling your attention to a new service.

How to Tell When You Have Mail

There are two ways to tell if you have mail, depending on whether the satellite receiver is turned on or off.

- If the satellite receiver is turned on, a mail icon appears in the upper right corner of the channel marker.
- If the satellite receiver is turned off, the power light on the front panel of the receiver flashes.

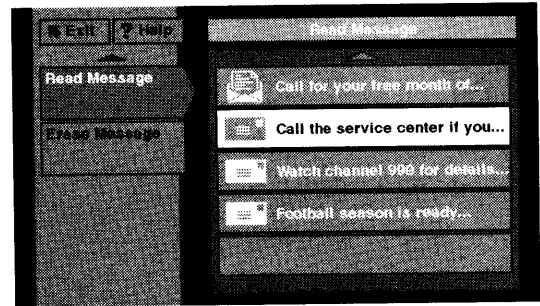

The mailbox screen

Checking Your Mail

Select Mailbox on the Main menu to view your mail.

1. Point to a message and press MENU/SELECT. The message is opened for you to read.
2. Press MENU/SELECT again to close the letter.

After you read a message and want to erase it, point to *Erase* and press MENU/SELECT. When you exit the display screen, messages not erased are saved in memory.

Alternate Audio Programs

Alternate Audio allows you to select different audio programs (when available) to be played with the video. For example, audio broadcast in a second language may be available for certain programs.

ALT (Alternate) Remote Button

Temporary audio selections are made by pressing ALT on the remote. Continue pressing the button to scroll through all available audio types. Once selected, the chosen audio remains selected until changed or until the satellite receiver is turned off.

Alternate Audio Display Screen

When you select Alternate Audio from the *Preferences* menu (located within the *Assistance* menu), the Alternate Audio display screen comes up.

Point to an audio language, and press MENU/SELECT. A check mark next to a language option means you have selected that language. The satellite system will then automatically set the audio program to the selected audio program type when that type is available.

Is your POWER Light Flashing?

Don't worry, your receiver's not broken. It means that you have mail.

Picture Size

The Picture Size display screen allows you to choose between a standard TV screen and a Cinema option. A standard TV screen has an aspect ratio of 4:3; the Cinema option has an aspect ratio of 16:9. To change the picture size, select *Preferences* from the *Assistance* menu, and then you can change the picture size.

System Test

The System Test display screen is accessed through the *Options* menu, and allows you to initiate diagnostic procedures on the satellite system. You should use this feature to get your Access Card number, or when your receiver doesn't seem to be working correctly. There are four separate tests: signal, tuning, phone connection, and access card.

A message screen appears, telling you whether the system passed each test. If your system fails a test, run the system test several times before concluding that there is a problem. Occasional fluctuations in the phone line or satellite signal can give temporary false failure readings.

New Access Card Setup

Periodically, your program provider may issue a replacement access card. The New Access Card function (located in the *Options* menu), allows you to transfer the information from the old card to the new one.

Follow the display screen prompts to initialize your new card. Once you have transferred the information to the new card, your old card becomes invalid.

Because your specific account information and custom settings are stored in the access card, power failures should have no effect on your satellite system.

Regarding Picture Size...

You should only use the Cinema option if you have a wide screen TV; using the Cinema option on a standard TV screen could crop the picture.

Using On-Line Help

On-line Help is available for all of the menus and display screens. The System provides Auto Help, Help buttons, and Menu Help.

Auto Help

Most menus contain a short description of that menu.

Help Buttons

Help buttons appear in many display screens. To see information about the display screen you are using, point to the Help button and press MENU/SELECT.

Point to Exit and press MENU/SELECT to remove the help message from the screen.

Menu Help

Select *About DSS* from the *Assistance* menu to choose from a list of on-line Help topics.

Choose from the following items in the *About DSS* menu to learn more about your satellite system.

Program Guide shows a screen-by-screen overview of the Program Guide features.

Menu System shows a screen-by-screen overview of the DSS® menu system.

Remote Control shows an on-screen display of the remote control. Point to the different remote buttons to see a brief description of the highlighted button.

Front Panel shows an on-screen display of the satellite receiver front panel. Point to the different front panel features to see a brief description of the highlighted feature.

Back Panel shows an on-screen display of the satellite receiver back panel. Point to the different back panel features to see a brief description of the highlighted feature.

Glossary shows a list of common DSS® and TV terms. Point to a glossary item to see a brief description.

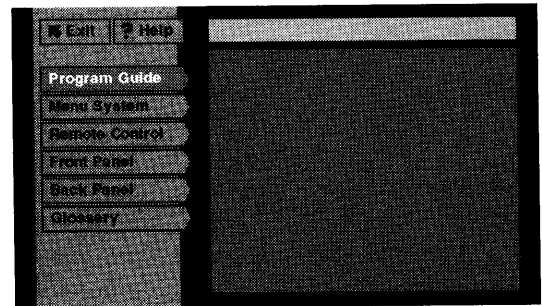

Select *About DSS* to see more information about your system

More Features

Use the *About DSS* menu (within the *Assistance* menu) to learn more about your system.

Connections

Things to Know Before Connecting Components

Protect Your Components from Power Surges

- Connect all components before plugging any power cords into the wall outlet.
- Always turn off the satellite receiver, TV and other components before you connect or disconnect any cables.

Position Cables Correctly to Avoid Audio Hum or Interference

- Insert all cable plugs firmly into their jacks.
- Place the audio/video cables to the sides of the TV's back panel instead of straight down the middle after you connect your components.
- Try not to coil any twin-lead cables and keep them away from the audio/video cables as much as possible.
- Make sure all antennas and cables are properly grounded. Refer to the Important Safeguards sheet packed with your unit.

Protect Your Components from Overheating

- Do not block ventilation holes in any of the components. Arrange the components so that air can circulate freely.
- Do not stack components.
- Allow adequate ventilation when placing your components in a stand.
- Place an amplifier or satellite receiver on the top shelf of the stand so heated air rising from it will not flow around other components.

CAUTION

Do not stack electronic components or other objects on top of the DSS Receiver. The slots on top of the receiver must be left uncovered to allow proper airflow to the unit. Blocking the airflow to the unit could impair performance or damage your receiver and other components.

Do not stack the DSS receiver on top of a "hot component" such as an audio power amplifier.

Connecting Your Satellite Receiver to Your TV

If your satellite system has not been professionally installed, or if you move your system or add a component, refer to these pages to help you connect your system.

Jacks and Cables

S-Video Jack and Cable (S-VHS)

The S-Video jack provides the best picture quality for your satellite system.

This jack is available on many TVs and is used in conjunction with audio cables to connect the satellite receiver to your TV. Remember also to connect the left and right audio cables because the S-Video jack carries only the picture signal, not the sound.



S-Video Jack

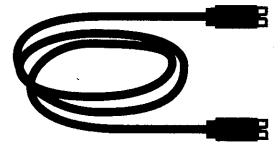

Audio/Video Jacks and Cables (RCA-type)

The audio/video jacks provide very good picture and stereo sound quality, and should be used if your TV has no S-Video jack.

These jacks are used for most audio/video connections between components. The satellite receiver audio/video jacks are color coded (yellow for video, red for right audio, and white for left audio). If your TV has only one input for audio (mono), connect it to the right (red) audio jack on the satellite receiver.



Audio/Video Jack

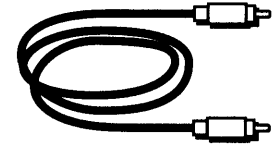

RF Jacks and Coaxial Cables (F-type)

The RF jacks provide good picture and mono sound quality, and are to be used if audio/video connections are not available for your TV.

These jacks are required for antenna or cable-TV connections. The RF jacks on the satellite receiver are labeled IN FROM ANT and OUT TO TV. The coaxial cable supplied with your satellite system is used to connect the RF jacks between the satellite receiver and your TV's antenna input.



RF Jack

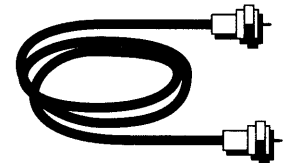

Choosing a Connection

The following pages show four examples of hookups commonly used to connect the satellite receiver with a TV and other components. Refer to your TV and VCR Owner's Manuals for more information on hooking up your specific components.

Connection A

Provides the best possible picture and stereo audio quality.

To use Connection A, you must have:

- TV with S-Video input, plus separate RF and audio/video inputs (jacks).
- VCR with RF and audio/video inputs and outputs
- S-Video, coaxial, and audio/video cables

Connection B

Provides very good picture and stereo audio quality.

To use Connection B, you must have:

- TV with separate RF and audio/video inputs (jacks)
- VCR with RF and audio/video inputs and outputs
- Coaxial and audio/video cables

Connection C

Provides good picture and mono audio quality.

To use Connection C, you must have:

- TV with RF input (jack)
- VCR with RF and audio/video inputs
- Coaxial and audio/video cables

Connection D

Provides good picture and mono audio quality.

To use Connection D, you must have:

- TV with RF input (jack)
- Coaxial cables

CAUTION

Do not stack electronic components or other objects on top of the DSS Receiver. The slots on top of the receiver must be left uncovered to allow proper airflow to the unit. Blocking the airflow to the unit could impair performance or damage your receiver and other components.

Do not stack the DSS receiver on top of a "hot component" such as an audio power amplifier.

Connection A

Best Picture and Sound Quality

To use this connection you must have:

- TV with separate RF, audio/video, and S-Video inputs (jacks)
- VCR with RF and audio/video inputs
- Coaxial, audio/video, and S-Video cables

To connect TV, VCR and antenna or cable box.

1. Connect coaxial cables as shown.
2. Connect audio/video cables as shown.
3. Connect S-Video cable as shown.

To receive DSS® programming:

1. Tune TV to receive the S-Video output from the satellite receiver.
2. Tune satellite receiver to desired channel.

To receive off-air programming (no cable box):

1. Turn off VCR and satellite receiver.
2. Tune TV to desired channel.

To receive off-air programming (with cable box):

1. Turn off VCR and satellite receiver.
2. Tune TV to cable box output channel (usually CH2, CH3, or CH4).
3. Tune cable box to desired channel.

To record DSS® programming:

1. Tune TV to receive S-Video output from satellite receiver.
2. Tune satellite receiver to desired channel.
3. Set your VCR to record on line input.

To view VCR programming:

1. Tune TV to VCR output channel (usually CH3 or CH4).

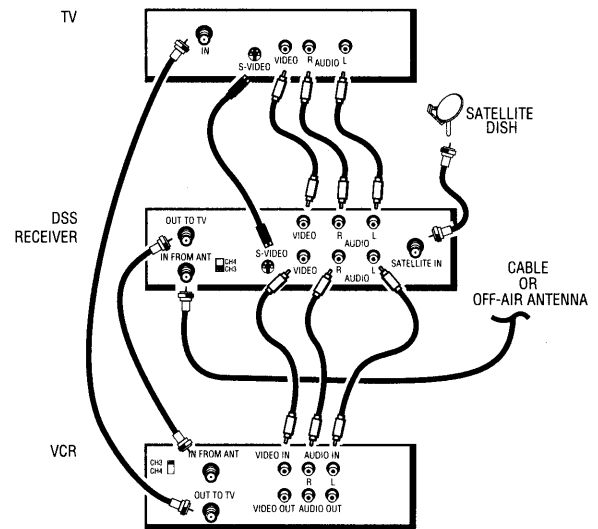

CAUTION

Do not stack electronic components or other objects on top of the DSS Receiver. The slots on top of the receiver must be left uncovered to allow proper airflow to the unit. Blocking the airflow to the unit could impair performance or damage your receiver and other components.

Do not stack the DSS receiver on top of a "hot component" such as an audio power amplifier.

Connection B

Very Good Picture and Sound Quality

To use this connection you must have:

- TV with separate RF and audio/video inputs (jacks)
- VCR with RF and audio/video inputs
- Coaxial and audio/video cables

To connect TV, VCR and antenna or cable box.

1. Connect coaxial cables as shown.
2. Connect audio/video cables as shown.

To receive DSS® programming:

1. Tune TV to receive line output from satellite receiver (often called Input 1).
2. Tune satellite receiver to desired channel.

To receive off-air programming (no cable box):

1. Turn off VCR and satellite receiver.
2. Tune TV to desired channel.

To receive off-air programming (with cable box):

1. Turn off VCR and satellite receiver.
2. Tune TV to cable box output channel (usually CH2, CH3, or CH4).
3. Tune cable box to desired channel.

To record DSS® programming:

1. Tune TV to receive line output from satellite receiver (Input1).
2. Tune satellite receiver to desired channel.
3. Set your VCR to record on line input.

To view VCR programming:

1. Tune TV to VCR output channel (usually CH3 or CH4).

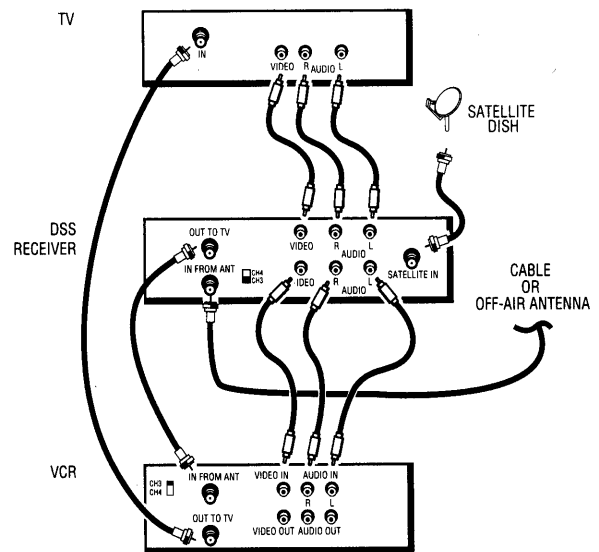

CAUTION

Do not stack electronic components or other objects on top of the DSS Receiver. The slots on top of the receiver must be left uncovered to allow proper airflow to the unit. Blocking the airflow to the unit could impair performance or damage your receiver and other components.

Do not stack the DSS receiver on top of a "hot component" such as an audio power amplifier.

Connection C

Good Picture and Sound Quality

To use this connection you must have:

- TV with RF input (jack)
- VCR with RF and audio/video inputs
- Coaxial and audio/video cables

To connect TV, VCR, and antenna or cable box.

1. Connect coaxial cables and audio/video cables as shown.

To receive DSS® programming:

- Tune TV to channel 3 or 4 (depending on how you set the CH3/CH4 switch on the back of the receiver).

To receive off-air programming (no cable box):

1. Turn off VCR and satellite receiver.
2. Tune TV to desired channel.

To receive cable programming (with cable box):

1. Turn off VCR and satellite receiver.
2. Tune TV to cable box output channel (usually CH2, CH3, or CH4).
3. Tune cable box to desired channel.

To record DSS® programming:

1. Tune TV to the channel on which you receive the DSS® signal.
2. Tune satellite receiver to desired channel.
3. Set VCR to record on line input.

To view VCR programming:

1. Tune TV to VCR output channel (usually CH3 or CH4).
2. Turn satellite receiver off.

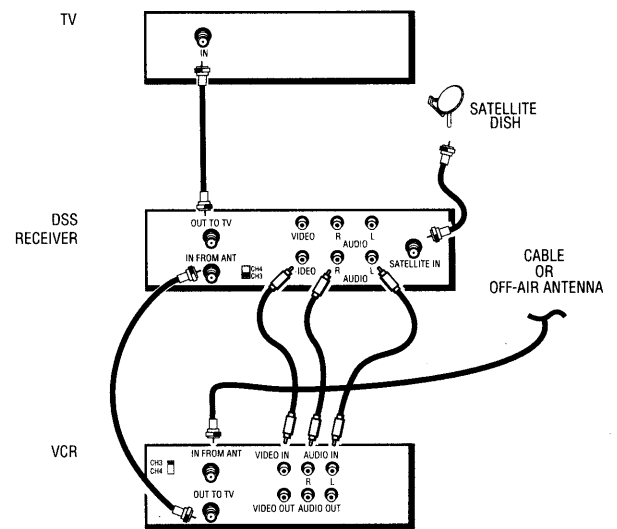

CAUTION

Do not stack electronic components or other objects on top of the DSS Receiver. The slots on top of the receiver must be left uncovered to allow proper airflow to the unit. Blocking the airflow to the unit could impair performance or damage your receiver and other components.

Do not stack the DSS receiver on top of a "hot component" such as an audio power amplifier.

Connection D

Good Picture and Sound Quality)

To use this connection you must have:

- TV with RF input
- Coaxial cables

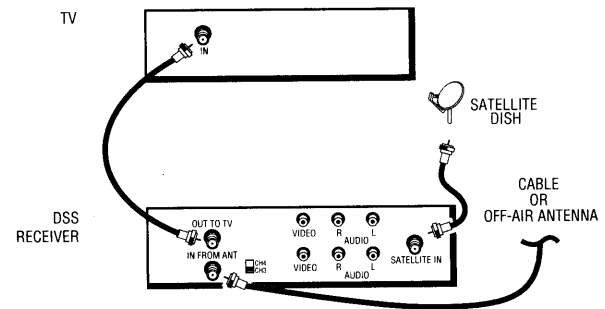

To connect TV and antenna or cable box:

1. Connect coaxial cables as shown.

To receive DSS® programming:

- Tune TV to channel 3 or 4 (depending on how you set the CH3/CH4 switch on the back of the receiver).

To receive off-air programming (no cable box):

1. Turn off satellite receiver.
2. Tune TV to desired channel.

To receive cable programming (with cable box):

1. Turn off satellite receiver.
2. Tune TV to cable box output channel (usually CH2, CH3, or CH4).
3. Tune cable box to desired channel.

CAUTION

Do not stack electronic components or other objects on top of the DSS Receiver. The slots on top of the receiver must be left uncovered to allow proper airflow to the unit. Blocking the airflow to the unit could impair performance or damage your receiver and other components.

Do not stack the DSS receiver on top of a "hot component" such as an audio power amplifier.

Interactive Setup

If you self-installed your satellite dish, you may have already used the interactive setup to find the dish pointing coordinates, acquire and fine-tune the signal, and run a system test.

If you need to run the interactive setup again, go to the *Assistance* menu and select *Setup*.

If you just want to check your dish pointing coordinates, or run the signal strength meter, select *Dish Pointing* from the *Main* menu.

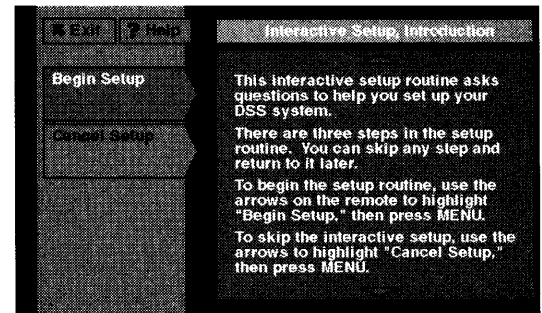

Disabling Interactive Setup

The Interactive Setup menus automatically appear on-screen the first time you plug in your receiver, and when power is restored after a power loss.

The final step of the Interactive Setup allows you to disable the automatic appearance of the Interactive Setup.

To enable it again, select *Setup* from the *Assistance* menu and then follow the Interactive Setup routine until the end, where you can choose to enable the automatic feature.

Reference

Parts of the DSS® System

One way to understand the DSS® system is to look at the different parts of the system—from the studio down to the satellite receiver and remote control in your home.

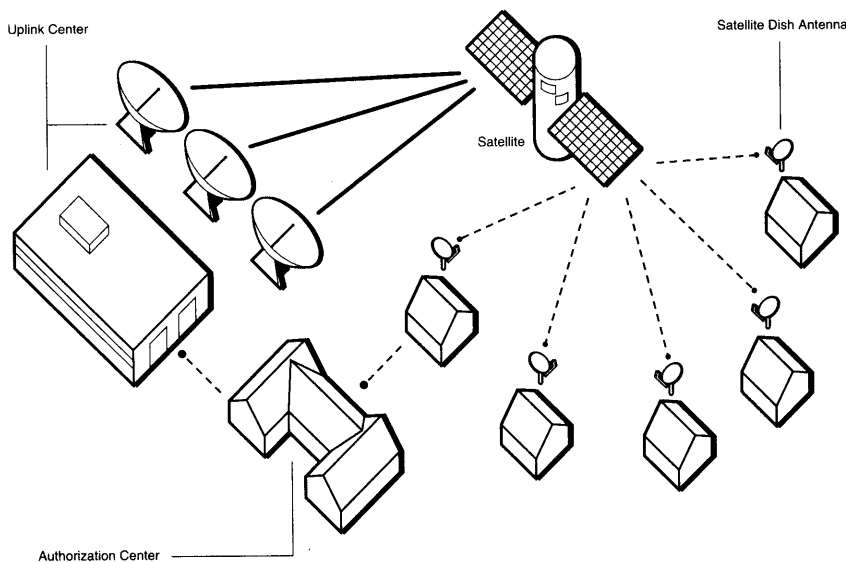

World View

These parts make up the DSS® system “big picture.”

Uplink Center Transmits programming up to the satellite.

Satellite Relays the programming signals back to your satellite dish. The satellite is parked above the equator, in geostationary orbit 22,300 miles above the earth.

Satellite Dish Antenna Receives the satellite signals. Because the satellite is so powerful, the dish can be as small as 18 inches.

Program Provider Authorization Center Processes billing statements. Your DSS® system is linked to the Service Center through the phone jack on the back of your satellite receiver.

Home View

These parts are inside of or attached to your house.

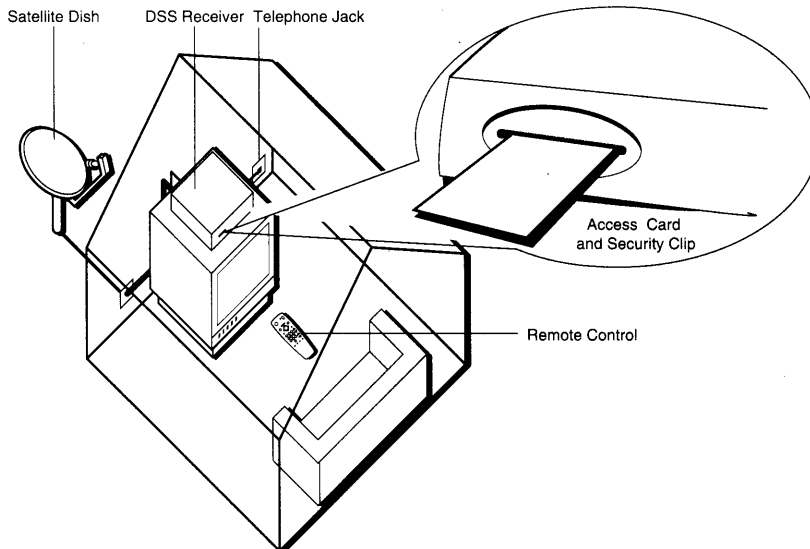

Satellite Dish Picks up the satellite's coded program information and relays it to your satellite receiver. (Your satellite dish may be installed in different locations on or around your house. The satellite dish must, however, be pointed in a southern direction toward the satellite.)

Satellite Receiver Receives the TV program information and sends it to your TV or VCR.

Telephone Jack Connects to the phone jack on the back of the satellite receiver. The satellite receiver uses a toll-free number once a month to update your access card. This update only takes a few seconds and ensures that you will have continuous service. The system automatically hangs up if you pick up the phone when the satellite receiver is calling out.

Television If your television is remote controllable, you can program the remote to change channels and volume.

Remote (included with your DSS® system) Controls the DSS® system as well as most remote controllable TVs, VCRs, and other devices. You need to program the remote to control specific brands of devices you own.

Access Card (installed in satellite receiver) Must be inserted for you to use the DSS® system! Provides system security and authorization of DSS® services. Do not remove the card except when issued a new card as a replacement for the original.

Controls and Buttons

This part of the Reference sections discusses the controls and buttons located on the receiver and the remote control.

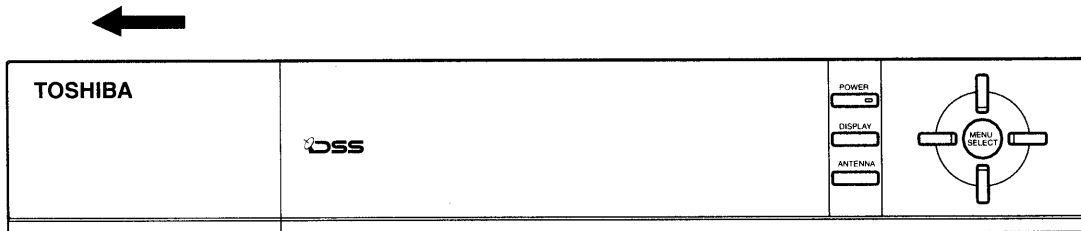

Slide open the door to get to the Access Card.

Front Panel Controls

POWER Turns the satellite receiver's power on or puts the unit into standby mode.

DISPLAY Brings up the on-screen channel marker.

ANTENNA Switches the source of the video signal from DSS® satellite signals to an off-air antenna or cable signal (if you are using the RF output from the satellite receiver).

NAVIGATION ARROWS (up, down, right, left) Press the navigation buttons to move the on-screen highlight up, down, left, or right. Using the arrows to highlight a menu item is also called "pointing."

MENU/SELECT Brings up the Main menu. If you are already in the menu system (or a program guide), press MENU/SELECT to select a highlighted choice.

ACCESS CARD Identifies you to your program providers. The DSS® system requires a valid access card.

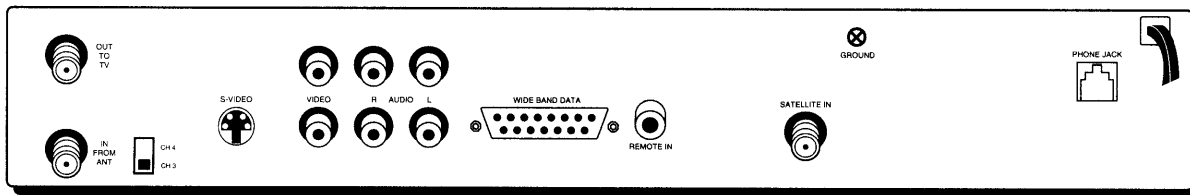

Back Panel

IN FROM ANT Use to connect an off-air antenna or cable TV signal to the DSS® system.

OUT TO TV Use to connect the satellite receiver to your TV. However, if your TV has audio/video jacks, you should use those jacks to get better picture and sound quality.

CH3/CH4 SWITCH If a coaxial cable is used to connect the satellite receiver to your TV, you must set the CH3/CH4 SWITCH. For example, to see the DSS® signal on TV channel 3, set the switch to 3.

S-VIDEO Provides the best picture quality. If your TV has S-VIDEO capability, use this jack along with the audio/video input jacks to connect the satellite receiver to your TV.

VIDEO Provides better picture quality than the OUT TO TV jack. If your TV has audio/video capability, use this jack to connect the satellite receiver to your TV. You must also connect the AUDIO jacks.

AUDIO (R and L) Provide better sound quality than the OUT TO TV jack. If your TV has audio/video capability, use these jacks to connect the satellite receiver to your TV. You must also connect the VIDEO jack.

WIDE BAND DATA PORT Allows you to connect the DSS® system to future services and accessories as they become available. A shielded cable and additional hardware may be required.

REMOTE IN Use in conjunction with remote control signal senders to control the receiver from another room.

SATELLITE IN Use to connect the satellite receiver to the satellite dish.

GROUND Use to ground the satellite receiver.

PHONE JACK Use to connect a phone line to the satellite receiver. The DSS® system uses a phone line connection to periodically call out to program providers.

Remote Control Buttons

- LIGHT** Use to turn remote control backlighting on or off.
- POWER** Turns the device you are controlling on or off.
- AUX** Use to control an auxiliary device (when programmed).
- VCR** Use to control a VCR (when programmed).
- TV** Use to control a TV (when programmed).
- DSS** Turns on the satellite receiver and tells the remote to control DSS® system functions.
- DIGIT KEYS (0 - 9)** Use the digit keys to tune directly to a channel. If you are in the menu system, use the digit keys to enter numbers for the time, date, channel, and passwords.
- VOL UP/DOWN** Adjusts the audio volume.
- RETURN** Moves you back and forth between the last two selected channels.
- MUTE** Turns off the sound. Press again to restore the sound.
- CHAN UP/DOWN** Use to scan up and down through the channels in the current channel list. If you are in the program guide or menu system, use the CHAN UP/DOWN buttons to page up and down a screen at a time.
- DISPLAY** Brings up the on-screen channel marker.
- SURF** Brings up the on-screen logos that correspond to your current channel list. Use the arrows to point to a logo and tune to that channel.
- GUIDE** Brings up the on-screen program guide. Continue to press the GUIDE button to toggle between the Grid and Info Guide options.
- EXIT** Removes the on-screen displays and returns to satellite TV viewing.
- ARROWS** Use the navigation arrows to move the on-screen highlight up, down, left, or right. Using the arrows to highlight a menu item is also called "pointing."
- MENU/SELECT** Brings up the Main menu. If you are already in the menu system (or a program guide), press MENU/SELECT to select a highlighted choice.
- ANT (Antenna)** Lets you switch the source of the video signal from the DSS® satellite signals to an off-air antenna or cable signal (if you are using the RF output from the satellite receiver).
- ALT (Alternate)** Use to step through the available languages or audio types for a program.
- TIMER** Use to access the Timers feature.
- FAV (Favorite)** Toggles through the favorite channel lists.
- VCR Control Buttons** Use when controlling an auxiliary device, such as a VCR.

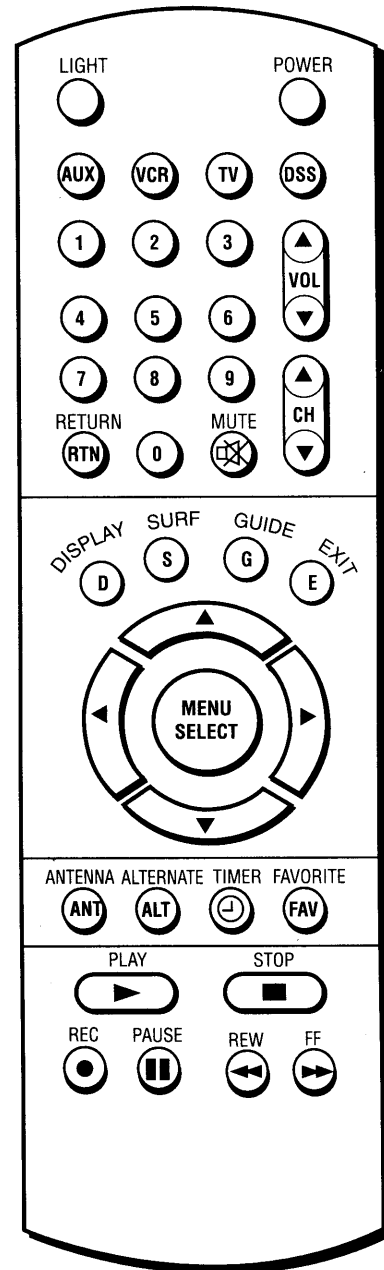

Programming the Remote Control Using Access Codes

The mode selection buttons (AUX, VCR, TV) can control the operation of a TV, VCR, and an auxiliary device (AUX) such as a remote controllable audio component.

The remote mode buttons need to be set to control other manufacturer's devices by the following methods.

Using the 3-Digit Code Method

1. Turn on the device you want to control.
2. Press the matching device button (AUX, TV, or VCR) and the RETURN button simultaneously.

The device button will light to indicate that it is in setting mode. If no new code is entered within 20 seconds, the light automatically turns off. The following steps must be entered with the light on.

3. Point the remote control toward the device and press the **three-digit brand code number** that matches the device (see code lists on the following pages).

If it is the correct code number, the device should turn off. If it fails to turn off the device, press the next three digit code number that is listed in the same brand name until the device turns off.

NOTE: This remote may not operate all models of the brands that are shown.

4. Once the device turns off, press the device button (AUX, TV, or VCR) again to store the correct code.

The lighted device button will blink twice to confirm storage.

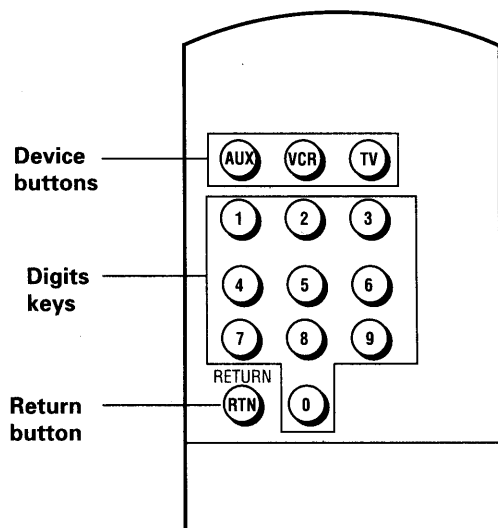

This remote may not operate all models of the brands that are shown. Use the codes shown in this manual.

Using the Search Method

If the previous steps fail to work with your brand, or your brand is not listed in the code lists on the following pages, use the following search method to set up your remote control.

1. Turn on the device you want to control.
2. Press the matching device button (AUX, TV, or VCR) and the RETURN button simultaneously.

The device button will light to indicate that it is in setting mode. If no new code is entered within 20 seconds, the light automatically turns off. The following steps must be entered with the light on.

3. Point the remote control toward the device and press the **CH ▲** button either one step at a time, or keep it pressed. Release the button as soon as it turns off the device.
 - If you go past the matching code, you can return to the matching code by pressing the **CH ▼** button one step at a time until your device turns on.
 - Once the device turns off (or on) confirm that you have found your matching code by pressing the POWER button. This should turn your device on or off.
4. Press the device button (AUX, TV, or VCR) to store the correct code.

The lighted device button will blink twice to confirm storage.

To Identify the 3-digit code number:

1. Press the device button (AUX, TV, or VCR) and the RETURN button on the remote control simultaneously. The device button will light.
2. Press the DISPLAY button and count the number of times the light blinks for each digit.

The 3-digit code is indicated by a 3-second interval of the light being turned off. For example, in the case of the 3-digit code number 012, the device button will blink **ten** times (for a "0"), **once**, and **twice**, with a 3-second interval between blinks.

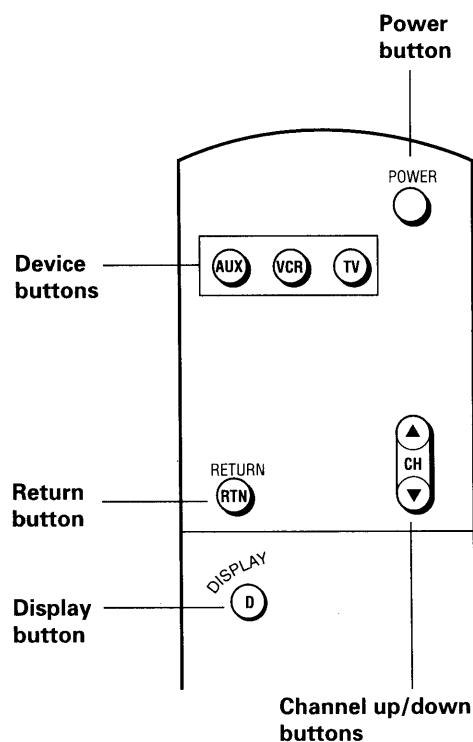

For future reference, write down the code numbers for each device in the space provided:

TV

--	--	--

AUX

--	--	--

VCR

--	--	--

Remote Codes

TV Codes

Admiral 072, 081, 161	JC Penney 001, 024, 030, 065, 101, 137, 143, 156, 160	RCA 001, 024, 056, 065, 137, 144, 156, 160, 161
A Mark 112, 143	JVC 034, 038	Realistic 007, 019, 043
Akai 001	KEC 043	Runco 072
Ampro 157	Kenwood 001	Sampo 001, 137
Amstrad 052	Kloss 059	Samsung 089, 101, 127, 137, 143, 160
Anam 043, 055, 056, 080, 112	KMC 143	Sanyo 007, 057
AOC 001, 112, 137	KTV 001, 043, 143	Scott 028, 043, 048, 137, 143
Candle 001, 137	Lodgenet 072	Sears 007, 015, 028, 030, 057, 094, 137, 143, 160
Cetronic 043	Logik 072	Sharp 014, 019, 028, 081, 137, 143
Citizen 001, 043, 101, 103, 137, 143	Luxman 137	Signature 072
Classic 043	LXI 007, 015, 052, 081, 160, 164	Sony 070, 126, 147, 172
Concerto 137	Magnavox ... 001, 059, 127, 137, 160, 164	Soundesign 028, 043, 137
Contec 039	Marantz 001, 024, 164	Spectricon 112
Coronado 143	Matsui 164	SSS 043, 137
Craig 043	Memorex 007, 072, 137	Sylvania 001, 059, 127, 137, 160, 164
Crown 043, 143	MGA 001, 024, 028, 137	Tandy 081
Curtis Mathes 001, 101, 137, 143	Mitsubishi 001, 024, 028, 137	Tatung 056
CXC 043	MTC 001, 101, 137	Technics 080
Daewoo 043, 055, 103, 127, 137, 143	NAD 015, 025	Techwood 137
Daytron 137, 143	NEC 001, 007, 019, 024, 056, 130, 134	Teknika 001, 024, 028, 043, 072, 101, 103, 137, 143
Dynasty 043	Nikei 043	Telerent 072
Electrohome 024, 143	Onking 043	TMK 137
Emerson 001, 005, 028, 043, 048, 096, 137, 143, 155	Onwa 043	Toshiba 007, 015, 030, 101
Fisher 007, 057	Optonica 019, 081	Totevision 143
Funai 028, 043	Panasonic 034, 080, 056, 164	Vidtech 137
Futuretech 043	Philco 001, 024, 056, 059, 137, 164	Wards 019, 028, 072, 137, 143, 164
GE 001, 034, 056, 130, 137, 144, 155, 157, 160, 161	Philips 001, 005, 038, 059, 070, 093, 137, 143, 160, 164, 172	Yamaha 001, 137
Goldstar 106, 112, 127, 137, 143	Pioneer 001, 025, 137	York 137
Hallmark 137	Portland 137, 143	Yupiteru 043
Hitachi 001, 007, 011, 137, 143	Proton 112, 137, 143, 171	Zenith 072, 095, 103, 157
Infinity 164	Proscan 144	Zonda 112
JBL 164	Quasar 034, 056	
	Radio Shack 019, 043, 127, 137, 143	

Audio Components (AUX)

Adcom 092	Magnavox 027	Realistic 019
Aiwa 071, 203	Marantz 001, 027, 087	Rotel 083
Bose 070	Mcintosh 238	Sansui 027, 111
B & K 096	Mitsubishi 242	Scott 019
Carver 027, 201	NAD 029, 048	Sharp 051, 175
Denon 105, 229	Nakamichi 111, 244	Sherwood 024, 038
Harman Kardon 233	Onkyo 107	Sony 018, 247
JC Penney 102	Panasonic 007, 195	Soundstream 118
Jensen 058	Philips 001, 087	Teac 019, 059
JVC 013	Pioneer 044, 050	Technics 007, 122
Kenwood 145	Quasar 007	Toshiba 112
Lexicon 120, 234	RCA 010	Yamaha 021, 031, 253

VCR Codes

Aiwa	034	Magin	040	Samsung	017, 040, 107, 109
Akai	043, 146	Magnavox	031, 034, 041, 067	Sansui	043, 048
Ampro	072	Marantz	012, 031, 067	Sanyo	001, 010, 014
Anam	031	Marta	101,	Scott	017, 131
Audio Dynamics	012, 023, 043	MEI	031	Sears	001, 008, 009, 010, 013, 014, 017, 031, 101
Broksonic	035	Memorex	001, 010, 014, 031, 034, 053, 072, 101	Sharp	031, 053, 054
Canon	031	MGA	059	Sony	001, 031, 052, 056, 057, 058
Craig	001, 040	Minolta	013	Soundesign	034
Curtis Mathes	031, 041	Mitsubishi	013, 059, 061	STS	013
Deawoo	010, 017	MTC	034, 040	Sylvania	031, 034, 067
DBX	012, 023, 043	Multitech	034	Symphonic	034
Dynatech	034, 053	NEC	012, 023, 043, 048	Tandy	010, 034
Electrohome	059	Nordmende	043	Tatung	043
Emerson	006, 017, 029, 031, 034, 035 101, 131	Optonica	053, 054	Teac	034, 043
Fisher	001, 008, 009, 010	Panasonic	031, 070	Technics	031, 070
Funai	034	Pentax	013, 031	Teknika	031, 034, 101
GE	031, 072, 107, 109, 144, 147	Philco	031, 034, 067	Thomas	034
Go Video	132	Philips	031, 034, 054, 067, 101	TMK	006
Goldstar	012, 013, 101, 123	Pilot	101	Toshiba	008, 013, 017, 047, 059, 082, 131
Harman Kardon	012	Pioneer	013, 021, 048	Totevision	040, 101
Hitachi	013, 026, 034, 043, 047	Pulsar	072	Unitech	040
Instantreplay	031	Quartz	014	Vector Research	012
JCL	031	Quasar	031	Video Concepts	012, 034
JC Penney	012, 013, 031, 040, 101	RCA	013, 031, 034, 040, 041, 107, 109, 144, 147	Videosonic	040
Jensen	043	Realistic	001, 008, 010, 014, 031, 034, 040, 053, 054, 101	Wards	001, 013, 017, 031, 034, 040, 053, 054, 131
JVC	012, 031, 043, 047, 048, 055, 060, 130	Rico	058	Yamaha	012, 034, 043
Kenwood	014, 043, 047, 048	Runco	072	Zenith	034, 048, 056, 058, 072, 080, 101
Lloyd	034	Salora	014		
LXI	001, 009, 013, 014, 017, 034, 101				

Glossary

The following is a list of terms used in this manual. There is also a glossary contained within the *Assistance* menu of your DSS® system.

Access Card

Identifies you to the DSS® service providers and is required for your DSS® system to work. Do not remove the access card except when a new card has been issued to replace the original.

Alternate Audio

Refers to the different audio channels that may be broadcast in conjunction with a video program. A foreign language translation is an example.

Attractions

Previews of special programs broadcast by your program provider.

Reference

Azimuth

Refers to the left-to-right positioning of your DSS® dish. When you enter your zip code (or latitude and longitude), the display screen provides the number corresponding to an azimuth setting for your location.

Elevation

Refers to the up and down positioning of your DSS® dish. When you enter your zip code (or latitude and longitude), the display screen provides the number corresponding to the elevation setting for your location.

Limits

There are three kinds of limits. The Rating Limit allows you to control program viewing of rated programs by ratings level. The Spending Limit controls spending on a cost-per-program basis. The Parent Approved channel list allows you to select which channels can be viewed when the system is locked.

Locks

The means of restricting access to certain features of the DSS® system. The lock is controlled by a 4-digit password. The closed or open lock icon in the channel marker indicates whether your system is locked or unlocked.

Mailbox

Stores incoming electronic messages sent to you by your program providers. The Mailbox is accessed through the on-screen menu system, and can store up to ten messages of forty characters each.

Main Menu

The first list of choices in the DSS® on-screen menu system. Press the MENU/SELECT button on the remote or front panel to bring up the Main menu.

Past Purchases

Detailed list of the programs that you have already purchased and viewed.

Point and Select

The method of using the remote control (or front panel) buttons to navigate to and make choices among the different parts of the on-screen displays.

Program Guides

Lists and updates the programs and services available from your program providers.

Rating Limit

Provides a means of restricting viewing of rated programs, based on program rating information. The operation of this feature depends upon the availability and accuracy of data supplied from and broadcast by the program provider.

Satellite Receiver

Receives, processes, and converts the digitally compressed satellite signals into audio and video.

Signal Meter

An on-screen display that indicates the relative strength of the satellite signal and sounds a test tone to help you lock in on the satellite signal. The signal meter is used when you adjust your satellite dish.

Spending Limit

Provides a means of restricting viewing; based on cost-per-program limit.

System Test

Provides a diagnostics check that can be used to determine that the main components of the DSS® system—signal, tuning, phone, and access card—are connected and working properly.

Upcoming Purchases

Detailed list of the programs you have purchased but have not yet been broadcast.

Troubleshooting

The DSS® System Test allows you to run a basic diagnostics check on your DSS® system. If you are experiencing any trouble with your system, run the system test.

Make sure that

- All connections—jacks, cables, etc. are correctly in place.
- There are batteries in the remote, and that they are working correctly.
- The access card is installed in the receiver.

Running the System Test

Follow these steps to run the diagnostics system test on your system.

1. Turn on your TV and the satellite receiver.
2. Press DSS to put remote in DSS® mode, then press MENU/SELECT to bring up the Main menu.
3. Point to and select *Options*.
4. Point to and select *System Test*. Follow the on-screen directions after the test is completed.

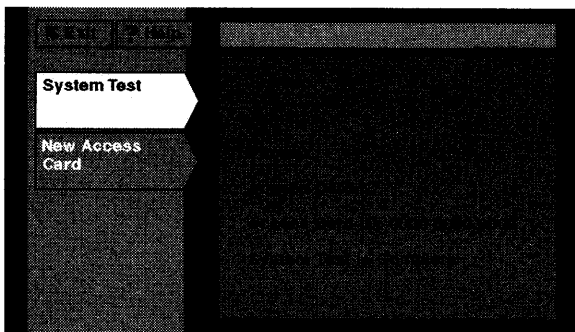

The system test screen.

5. If your system does not pass the system test, check any of these potential trouble areas: cabling, pointing the satellite dish, phone connection, and access card.

LIMITED WARRANTY

TOSHIBA DIGITAL SATELLITE SYSTEM

Toshiba America Consumer Products, Inc. (TACP) makes the following limited warranty. These limited warranties extend to the original consumer purchaser or any person receiving this system as a gift from the original consumer purchaser and no other purchaser or transferee.

LIMITED WARRANTY - ONE (1) YEAR PARTS, NINETY (90) DAYS LABOR

WHAT IS COVERED

Any defect in materials and workmanship. This warranty applies to the DSS® System. The DSS® System includes the satellite receiver, remote control unit, outdoor antenna, LNB converter, access card and included hardware.

WHAT TACP WILL DO

Within 90 days from your purchase:

Exchange the defective portion of the DSS® System with a new or, at TACP's option, refurbished unit, without charge to you.

After 90 days and within 1 year:

Exchange the defective portion of the DSS® System with a new, or at TACP's option, refurbished unit. If the defect is in the satellite receiver, you will be charged a flat fee for the labor portion of the repair. Labor costs for the removal and re-installation of any equipment are your responsibility.

WHAT YOUR WARRANTY DOES NOT COVER

- Any DSS accessory not included in the DSS system.
- Original or subsequent installation.
- Damage caused by acts of God, such as but not limited to lightning or power surge damage.
- Adjustment of customer controls including alignment of the satellite dish.
- Damage from misuse, accident, improper installation, improper maintenance, use in violation of instructions by TACP, or neglect.
- Units or parts which have been lost or discarded by you.
- A unit that has been modified or incorporated into other products or is used for institutional or commercial purposes.
- Batteries for remote control hand units.
- Units purchased, serviced or operated outside the continental USA.
- Loss of programming.
- Shipping damage if the unit was not packed in the manner prescribed by TACP.
- Warranty is void if model / serial number tag is missing, altered, defaced, or rendered illegible.

You should read the Toshiba Digital Satellite Receiver Operation Manual thoroughly before using this product. You should also ensure that your name and address are on file as an owner of this product by completing and mailing the enclosed registration card within ten days after you, or the person who has given you this product as a gift, purchased this product. This is one way to enable TACP to establish the date of purchase of the product, as well as to provide you with better customer service and improved products. Failure to return this card will not affect your rights under this warranty so long as you retain other proof of purchase such as a bill of sale.

How you get service:

- Have the unit's date of purchase, model and serial number ready and call 1-888-TOSH-DSS (1-888-867-4377). The model / serial number information is on the back of the satellite receiver.
- A Customer Service Representative will troubleshoot the problem over the phone.
- If the Customer Service Representative determines that you should receive a replacement receiver, you will be provided with a Return Authorization (RA) number and instructions on returning the defective receiver. No returns will be accepted without an RA number.
- If the Customer Service Representative determines that the antenna / dish, remote control or access card is defective he/she will arrange for its repair or replacement.
- If the Customer Service Representative determines that the installation is the cause of the problem, he/she will refer you to the closest authorized installer for installation service. Installation service is your responsibility.

To receive a replacement receiver before you return yours:

1. Provide your VISA or Mastercard account number and expiration date to your Customer Service Representative. This is for security purposes only and your account will not be charged at this time.
2. Provide a home or business address where TACP can ship the replacement receiver.
3. TACP will send you a replacement receiver via courier, next business day delivery along with detailed instructions on how to return the defective receiver.
4. If TACP receives the defective receiver within 20 days from the date TACP issued the RA, only items not covered by warranty, if any, will be charged to your account. Please refer to "WHAT YOUR WARRANTY DOES NOT COVER" for a list of items not covered by this warranty.

If the defective receiver is not received within 20 days, the suggested retail value of the replacement receiver will be charged to your credit card. This amount will be credited if the defective receiver is subsequently received.

If you do not wish to provide your credit card number:

1. You will need to return the defective receiver before you receive a replacement.
2. Your Customer Service Representative will provide detailed instructions on the correct packaging of the defective receiver and schedule a convenient time for pick-up.
3. TACP will dispatch a courier to an agreed location to pick up the defective receiver.
4. When TACP receives your defective receiver TACP will ship a replacement to the agreed location next business day delivery.

Reference

Check list for returning a defective receiver:

- Keep your Access Card and Accessories.
- Repackage the defective receiver in the original packaging or have it professionally packaged.
- Include a copy of the bill of sale to verify the defective receiver's warranty eligibility.
- Include a brief note describing the problem with the receiver.
- Include your name, address and phone number.

TACP assumes no responsibility for warranty shipments from the consumer to the factory if not shipped in the manner prescribed by TACP

How state law relates to warranty:

ALL WARRANTIES IMPLIED BY STATE LAW, INCLUDING THE IMPLIED WARRANTIES OF MERCHANTABILITY AND FITNESS FOR A PARTICULAR PURPOSE ARE EXPRESSLY LIMITED TO THE DURATION OF THE LIMITED WARRANTIES SET FORTH ABOVE. Some states do not allow limitations on how long an implied warranty lasts, so the above limitation may not apply to you. WITH THE EXCEPTION OF ANY WARRANTIES IMPLIED BY STATE LAW AS HEREBY LIMITED, THE FOREGOING EXPRESS WARRANTY IS EXCLUSIVE AND IN LIEU OF ALL OTHER WARRANTIES, GUARANTEES, AGREEMENTS AND SIMILAR OBLIGATIONS OF MANUFACTURER OR SELLER WITH RESPECT TO THE REPAIR OR REPLACEMENT OR ANY PRODUCT OR PARTS. IN NO EVENT SHALL TACP OR THI BE LIABLE FOR CONSEQUENTIAL OR INCIDENTAL DAMAGES. Some states do not allow the exclusion or limitation of incidental or consequential damages so the above limitation may not apply to you.

No person, agent, distributor, dealer, service station, or company is authorized to change, modify, or extend the terms of these warranties in any manner whatsoever. The time within which an action must be commenced to enforce any obligation of TACP and THI arising under this warranty or under any statute or law of the United States or any state thereof, is hereby limited to one year from the date you discovered the defect. This limitation does not apply to implied warranties arising under state law. Some states do not permit limitation of the time within which you may bring an action beyond the limits provided by state law so the above provision may not apply to you. This warranty gives you specific legal rights and you may also have other rights which vary from state to state.

IF YOUR DSS® RECEIVER IS OUT OF LABOR AND PARTS WARRANTY

After one (1) year you will be charged a flat rate for parts, labor, and return shipping.

1. Call 1-888-TOSH-DSS (1-888-867-4377) for an RA number.
2. Repackage your defective receiver in its original packaging or have it professionally packaged and return it to the address given by the Customer Service Representative.
3. Write the RA number on the outside of the carton. Make sure you insure your shipment in case of theft or damage. TACP will not be responsible for products that are lost, stolen, or damaged in transit to TACP.
4. Shipping charges must be prepaid. We will not accept COD shipments.
5. Include a brief note explaining the problem, your name, address, and phone number.
6. Include a cashier's check or money order for payment in the amount described by the Customer Service Representative.
7. Removal and re-installation of any equipment are your responsibility.
8. TACP will repair only Toshiba brand DSS® systems.

QUESTIONS AND COMMENTS

Call toll free: 1-888-TOSH-DSS (1-888-867-4377) or

send written inquiries to:

Toshiba America Consumer Products
Satellite Service Center - DSS
1010 Johnson Drive
Buffalo Grove, IL 60089

DO NOT SHIP PRODUCTS TO THE ABOVE ADDRESS

FCC Registration Information

Your DSS® equipment is registered with the Federal Communications Commission and is in compliance with parts 15B and 68, FCC Rules and Regulations.

1. Notification to the Local Telephone Company.

On the bottom of this equipment is a label indicating among other information, the FCC Registration number and Ringer Equivalence Number (REN) for the equipment. You must, upon request, provide this information to your telephone company.

The REN is useful to determine the number of devices you may connect to your telephone line and still have all these devices ring when your telephone number is called. In most (but not all) areas, the sum of the RENs of all devices connected to one line should not exceed 5. To be certain of the number of devices you may connect to your line as determined by the REN, you should contact your local telephone company.

Notes: This equipment may not be used on coin service provided by the telephone company.

Party lines are subject to state tariffs, and therefore, you may not be able to use your own telephone equipment if you are on a party line. Check with your local telephone company.

Notice must be given to the telephone company upon permanent disconnection of your DSS® equipment from your line.

2. Rights of the Telephone Company.

Should your equipment cause trouble on your line which may harm the telephone network, the telephone company shall, where practicable, notify you that temporary discontinuance of service may be required. Where prior notice is not practicable and the circumstances warrant such action, the telephone company may temporarily discontinue service immediately. In case of such temporary discontinuance, the telephone company must: (1) promptly notify you of such temporary discontinuance (2) afford you the opportunity to correct the situation and (3) inform you of your right to bring a complaint to the Commission pursuant to procedures set forth in Subpart E of Part 68, FCC Rules and Regulations.

The telephone company may make changes in its communications facilities, equipment, operations of procedures where such action is required in the operation of its business and not inconsistent with FCC Rules and Regulations. If these changes are expected to affect the use or performance of your telephone equipment, the telephone company must give you adequate notice, in writing, to allow you to maintain uninterrupted service.

Radio Interference

This equipment has been type tested and found to comply with the limits for a Class B Digital Device in accordance with the specifications in Part 15 of FCC Rules. These rules are designed to provide reasonable protection against radio and television interference in a residential installation. This equipment generates, uses and can radiate radio frequency energy and, if not installed and used in accordance with the instructions, may cause harmful interference to radio communications. However, there is no guarantee that interference will not occur in a particular installation.

If this equipment does cause interference to radio or television reception (which you can determine by turning the equipment off and on), try to correct the interference by one or more of the following measures.

- Reorient or relocate the receiving antenna (that is, the antenna for radio or television that is "receiving" the interference).
- Change the position of the DSS® satellite receiver with respect to the radio or television equipment that is receiving interference.
- Move the DSS® satellite receiver away from the equipment that is receiving interference.
- Plug the DSS® satellite receiver into a different wall outlet so that the DSS® satellite receiver and the equipment receiving interference are on different branch circuits.

If these measures do not eliminate the interference, please consult your dealer or an experienced radio/television technician for additional suggestions. Also, the Federal Communications Commission has prepared a helpful booklet, "How To Identify and Resolve Radio/TV Interference Problems". This booklet is available from the U.S. Government Printing Office, Washington, D.C. 20402. Please specify stock number 004-000-00345-4 when ordering copies.

Index

A

- Access Card 38
 - new card setup 26
 - number, 26
- Alternate Audio display
 - screen 25
- Alternate audio programs 24-25
- Attractions Guide 10, 22
- Audio/video jacks 30
- Auto Help 27

B

- Back Panel controls 40
 - AUDIO RIGHT AND LEFT 40
 - IN FROM ANT 40
 - OUT TO TV 40
 - PHONE JACK 40
 - S-VIDEO 40
 - SATELLITE IN 40
 - VIDEO 40
 - WIDE BAND DATA port 40
- Batteries
 - installing in the remote 6
- Buy and Record Option 22

C

- Channel Guide 10
- Channel logos, tuning by 24
- Cinema screen 26
- Coming attractions 22

E

- Exiting a menu 13
- Exiting A Program Guide 12
- Exit button (remote) 41

F

- Flashing POWER indicator light 25
- Front Panel controls 39
 - ANTENNA 39
 - DISPLAY 39
 - MENU/SELECT 39
 - POWER 39

G

- Grid Guide 9

H

- Help 13, 27
 - auto-help 27
 - menu help 27
 - on-line 27
- Help Buttons 27

I

- Info Guide 9
- Interactive setup 36

M

- Mailbox 24, 25
 - checking your mail 25
 - deleting mail messages 25
- Main menu 13
- Menu Help 27
- MENU•SELECT button
 - (remote) 4
- Menus
 - Assistance 14
 - Dish Pointing 14
 - exiting from 13
 - Mailbox 14
 - Options 14
 - Program Guide 14
 - Purchases 14
 - Timers 14

O

- On-Line Help 27

P

- Password, system
 - forgetting 20
- Past purchases 23
- Pay-per-view 21
- Picture Size, changing 26
- PPV (pay-per-view) 21
- Program Guide 7
 - All Button 12
 - Arrow button 11
 - Attractions Guide 10
 - Accessing 7
 - Channel guide 10
 - Grid Guide 9
 - Other 12

- scrolling channel by channel 7
- scrolling page by page 8
- selecting a guide 8
 - from the Main Menu 8
- sorting 11
- Sports button 12
- Theme button 12
- Topic Guide 10
- tuning to a channel 8
- types of 9
- Program Provider Authorization
 - Center 37
- Programming the Remote 42
 - to control a TV 42
- Purchases menu 23
- Purchasing a PPV program 21

R

- Receiver 38
- Remote control
 - buttons 41
 - installing batteries 6
 - programming 42
- RF jacks 30

S

- S-Video jack 30
- Satellite 37
- Session unlock 20
- Sorting the Program Guide 11
- Spending limits 17
- SURF button 24
- Surf feature 24
- System controls 15
- System Test 26

T

- Timer feature
 - setting up 24
- Topic Guide 10
- Troubleshooting 47
- Tuning to a PPV program 21

U

- Unlocking the system 20
 - temporarily 20
- Upcoming purchases 23
- Uplink Center 37

TOSHIBA AMERICA CONSUMER PRODUCTS, INC.

BRANCH OFFICE/CHICAGO: 1010 JOHNSON DRIVE, BUFFALO GROVE, ILLINOIS 60089-6900

TECHNICAL SUPPORT: 888-TOSH DSS (888-867-4377)