

DIRECTV® Multi-Room Receiver User Manual

DSR **660**



Congratulations on purchasing this Philips product.
We've included everything you need to get started.

Thank you for making Philips a part of your home!

PHILIPS



Know these
safety symbols



 This "bolt of lightning" indicates uninsulated material within your unit may cause an electrical shock. For the safety of everyone in your household, please do not remove product covering.

 The "exclamation point" calls attention to features for which you should read the enclosed literature closely to prevent operating and maintenance problems.

WARNING: TO PREVENT FIRE OR SHOCK HAZARD, DO NOT EXPOSE THIS EQUIPMENT TO RAIN OR MOISTURE.

CAUTION: To prevent electric shock, match wide blade of plug to wide slot of the outlet and fully insert.

ATTENTION: Pour éviter les choc électriques, introduire la lame la plus large de la fiche dans la borne correspondante de la prise et pousser jusqu'au fond.

For Customer Use

Enter below the Model, Serial and Access Card Number and Receiver ID located on the rear panel of the DIRECTV® Multi-Room Receiver. Retain this information for future reference.

Model No. _____

Serial No. _____

Access Card No. _____

Receiver ID _____

NOTE: This owner's manual may be used with several different models. Not all features (or drawings) discussed in this manual will necessarily match those found with your system. This is normal and does not require you contacting your dealer or requesting service.

DIRECTV programming sold separately. ACTIVATION OF PROGRAMMING MAY BE SUBJECT TO CREDIT APPROVAL AND REQUIRES VALID SERVICE ADDRESS, SOCIAL SECURITY NUMBER AND/OR MAJOR CREDIT CARD. DEPOSIT OR PREPAYMENT MAY BE REQUIRED. Programming subject to change. DIRECTV service not available outside the U.S. DIRECTV programming is sold separately and independently of DIRECTV System hardware. A valid programming subscription is required to operate DIRECTV System hardware. Activate your DIRECTV programming today at 1-800-DIRECTV (1-800-347-3288)

DIRECTV and the Cyclone Design logo, ADVANCED PROGRAM GUIDE and DIRECTV INTERACTIVE are trademarks of DIRECTV, Inc., a unit of Hughes Electronics Corp., and are used with permission.

Philips is a registered trademark of Koninklijke Philips Electronics, NV.

This product includes software developed by the University of California, Berkeley and its contributors.

Copyright (c) 1982, 1986, 1988, 1990, 1993

The Regents of the University of California. All rights reserved.

Redistribution and use in source and binary forms, with or without modification, are permitted provided that the following conditions are met:

1. Redistribution of source code must retain the above copyright notice, this list of conditions and the following disclaimer.
2. Redistribution in binary form must reproduce the above copyright notice, this list of conditions and the following disclaimer in the documentation and/or other materials provided with the distribution.
3. All advertising materials mentioning features or use of this software must display the following acknowledgment: This product includes software developed by the University of California, Berkeley and its contributors.
4. Neither the name of the University nor the names of its contributors may be used to endorse or promote products derived from this software without specific prior written permission.

THIS SOFTWARE IS PROVIDED BY THE REGENTS AND CONTRIBUTORS "AS IS" AND ANY EXPRESS OR IMPLIED WARRANTIES, INCLUDING, BUT NOT LIMITED TO, THE IMPLIED WARRANTIES OF MERCHANTABILITY AND FITNESS FOR A PARTICULAR PURPOSE ARE DISCLAIMED. IN NO EVENT SHALL THE REGENTS OR CONTRIBUTORS BE LIABLE FOR ANY DIRECT, INDIRECT, INCIDENTAL, SPECIAL, EXEMPLARY, OR CONSEQUENTIAL DAMAGES (INCLUDING, BUT NOT LIMITED TO, PROCUREMENT OF SUBSTITUTE GOODS OR SERVICES; LOSS OF USE, DATA, OR PROFITS; OR BUSINESS INTERRUPTION) HOWEVER CAUSED AND ON ANY THEORY OF LIABILITY, WHETHER IN CONTRACT, STRICT LIABILITY, OR TORT (INCLUDING NEGLIGENCE OR OTHERWISE) ARISING IN ANY WAY OUT OF THE USE OF THIS SOFTWARE, EVEN IF ADVISED OF THE POSSIBILITY OF SUCH DAMAGE.

The software included in this product is based in part on the work of the Independent JPEG-Group and on the PNG Reference Library which is copyright © 1998-2001 Glenn Randers-Pehrson, copyright © 1996, 1997 Andreas Dilger, and copyright © 1995, 1996 Guy Eric Schalnat, Group 42, Inc.

For the software in this product no license under Philips IPR is granted, except for the use of the software in combination with this product.



Safety Instructions - Read Before Operating Equipment

WARNING: TO PREVENT FIRE OR SHOCK HAZARD, DO NOT EXPOSE ANY ELECTRICAL EQUIPMENT TO RAIN OR MOISTURE.

1. **Read Instructions** – All the safety and operating instructions should be read before the appliance is operated.
2. **Retain Instructions** – The safety and operating instructions should be retained for future reference.
3. **Heed Warnings** – All warnings on the appliance and in the operating instructions should be adhered to.
4. **Follow Instructions** – All operating and use instructions should be followed.
5. **Attachments** – Do not use attachments not recommended by the manufacturer as they may cause hazards.
6. **Water and Moisture** – Do not use this product near water – for example, near a bath tub, wash bowl, kitchen sink, or laundry tub, in a wet basement, near a swimming pool, etc.
7. **Accessories** – Do not place this product on an unstable cart, stand, tripod, bracket, or table. The product may fall, causing serious injury to a child or adult, and serious damage to the appliance. Use only with a cart, stand, tripod, bracket, or table recommended by the manufacturer or sold with the product. Any mounting of the appliance should follow the manufacturer's instructions, and should use a mounting accessory recommended by the manufacturer.
- 7A  An appliance and cart combination should be moved with care. Quick stops, excessive force, and uneven surfaces may cause the appliance and cart combination to overturn.
8. **Ventilation** – Slots and openings on the cabinet are provided for ventilation and to ensure reliable operation of the product and to protect it from overheating. These openings must not be blocked or covered. The openings should never be blocked by placing the product on a bed, sofa, rug, or other similar surface. This product should not be placed near or over a radiator or heat register. This product should not be placed in a built-in installation such as a bookcase or rack unless proper ventilation is provided or the manufacturer's instructions have been adhered to.
9. **Power Sources** – This product should be operated only from the type of power source indicated on the marking label. If you are not sure of the type of power supply to your home, consult your appliance dealer or local power company.
10. **Grounding or Polarization** – This product is equipped with a polarized alternating-current line plug (a plug having one blade wider than the other). This plug will fit into the power outlet only one way. This is a safety feature. If you are unable to insert the plug fully into the outlet, try reversing the plug. If the plug should still fail to fit, contact your electrician to replace your obsolete outlet. Do not defeat the safety purpose of the polarized plug.
11. **Power Cord Protection** – Route power supply cords so that they are not likely to be walked on or pinched by items placed upon or against them. Pay particular attention to cords at plugs, convenience receptacles, and the point where they exit from the appliance.
12. **Outdoor Antenna Grounding** – If an outside antenna or cable system is connected to the product, be sure the antenna or cable system is grounded to provide protection against voltage surges and built-up static charges.

Section 810 of the National Electrical Code, ANSI/NFPA 70, provides information with regard to proper grounding of the mast and supporting structure, grounding of the lead-in wire to an antenna discharge unit, size of grounding conductors, location of antenna-discharge unit, connection to grounding electrodes, and requirements for the grounding electrode. See Figure A.
13. **Phone Line Use** – Avoid using a telephone (other than a cordless type) during an electrical storm. There may be a remote risk of electric shock from lightning. Do not use the telephone to report a gas leak in the vicinity of the leak.
14. **Lightning** – For added protection for this product during a lightning storm or when it is left unattended and unused for long periods of time, unplug it from the wall outlet and disconnect the antenna or cable system. This will prevent damage to the product from lightning and power line surges.

15. **Power Lines** – An outside antenna system should not be located in the vicinity of overhead power lines or other electric light or power circuits, or where it can fall onto such power lines or circuits. When installing an outside antenna system, extreme care should be taken to keep from touching such power lines or circuits as contact with them might be fatal. Refer to Satellite Dish Antenna Assembly & Alignment Guide.
16. **Overloading** – Do not overload wall outlets and extension cords as this can result in a risk of fire or electric shock.
17. **Object and Liquid Entry** – Never push objects of any kind into this product through openings as they may touch dangerous voltage points or short-out parts that could result in a fire or electric shock. Never spill liquid of any kind on the product.
18. **Servicing** – Do not attempt to service this product yourself, as opening or removing covers may expose you to dangerous voltage or other hazards. Refer all servicing to qualified service personnel.
19. **Damage Requiring Service** – Unplug this product from the wall outlet and refer servicing to qualified service personnel under the following conditions:
 - a. When the power supply cord or plug is damaged.
 - b. If liquid has been spilled, or objects have fallen into the product.
 - c. If the product has been exposed to rain or water.
 - d. If the product does not operate normally when following the operating instructions. Adjust only those controls that are covered by the operating instructions, as an improper adjustment of other controls may result in damage and will often require extensive work by a qualified technician to restore the product to its normal operation.
 - e. If the product has been dropped or the cabinet has been damaged in any way.
 - f. When the product exhibits a distinct change in performance – this indicates a need for service.
20. **Replacement Parts** – When replacement parts are required, be sure the service technician has used replacement parts specified by the manufacturer or which have the same characteristics as the original part. Unauthorized substitutions may result in fire, electric shock or other hazards.
21. **Safety Check** – Upon completion of any service or repairs to this product, ask the service technician to perform safety checks to determine that the product is in proper operating condition.
22. **Carts and Stands** – The appliance should be used only with a cart or stand recommended by the manufacturer.
23. **Heat** – The product should be situated away from heat sources such as radiators, heat registers, stoves, or other products that produce heat.

Operating Temperature: 40 to 110°F
Storage Temperature: 15 to 155°F

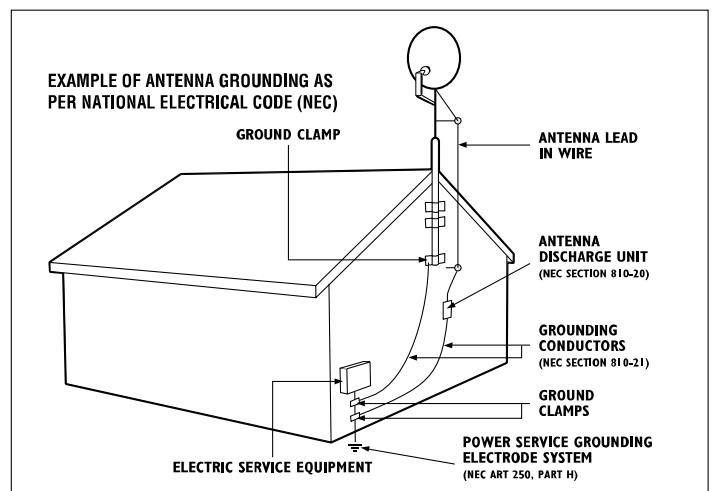

Figure A

Safety Instructions (cont'd), General Information

This device incorporates an anticopy process technology that is protected by U.S. patents and other intellectual property rights. The anticopy process is licensed for non-commercial, home use only. Reverse engineering or disassembly is prohibited.

NOTE TO CATV SYSTEM INSTALLER

Article 820-40 of the NEC (National Electrical Code) provides guidelines for proper grounding and, in particular, specifies that the cable ground shall be connected to the grounding system of the building, as close to the point cable entry as practical.

WARNING

This device complies with Part 15 of the FCC Rules.

Operation is subject to the following two conditions:

- (1) This device may not cause harmful interference, and
- (2) This device must accept any interference received, including interference that may cause undesired operation.

FCC Regulations and Information

This equipment has been tested and found to comply with the limits for a Class B digital device, pursuant to Part 15 of the FCC Rules. These limits are designed to provide reasonable protection against harmful interference in a residential installation. This equipment generates, uses and can radiate radio frequency energy and, if not installed and used in accordance with the instructions, may cause harmful interference to radio communications.

However, there is no guarantee that interference will not occur in a particular installation. If this equipment does cause harmful interference to radio or television reception (which you can determine by turning the equipment off and on), you are encouraged to try to correct the interference by one or more of the following measures:

Reorient or relocate the receiving satellite dish antenna.

Increase the separation between the equipment and receiver.

Connect the equipment into an outlet on a circuit different from that to which the receiver is connected.

Consult the dealer or an experienced radio/TV technician for help.

In order to comply with FCC part 15 requirements, the product must be installed by a DIRECTV authorized professional installer with a cable of type RG6 or RG59 at the TV2 output.

The output TV2 of this device is intended to be attached to a receiver that is not used to receive over-the-air broadcast signals. Connection of this device in any other fashion may cause harmful interference to radio communications and is in violation of the FCC Rules, Part 15.

IMPORTANT

Any changes or modifications to the equipment by the user not expressly approved by the warranty or manufacturer could void the user's authority to operate the equipment.

Domestic use U. S. A – For units used at 120V, use only the power supply cord which is supplied with the product.

ANALOG DEVICE WARNINGS

Federal Communication Commission (FCC) Part 68 and Administrative Council for Terminal Attachments (ACTA)

This device complies with Part 68 of the FCC rules and the requirements adopted by the ACTA. A label on the bottom panel of this equipment contains, among other information, a product identifier in the format US:AAAEQ##TXXXX. If requested, this number must be provided to the telephone company. The REN is used to determine the number of devices that may be connected to a telephone line. Excessive RENs on the telephone line may result in the devices not ringing in response to an incoming call. In most, but not all areas, the sum of RENs should not exceed five (5.0). To be certain of the number of devices that may be connected to a line, as determined by the total RENs, contact the local telephone company. The REN for this product is part of the product identifier that has the format US:AAAEQ##TXXXX. The digits represented by ## are the REN without a decimal point. For the DSR 660, 01 means a REN of 0.1. Note: RENs are associated with loop-start and ground-start ports. Do not use for E & M or digital ports.

This equipment uses the following USOC jack: RJ-11C. No modular plug is provided with this equipment.

A plug and jack used to connect the DSR 660 to the premises wiring and telephone network must comply with the applicable FCC Part 68 rules and requirements adopted by ACTA. A compliant telephone cord is provided with this product. It is designed to be connected to a compatible modular jack that is also compliant. See installation instruction for details.

If the DSR 660 causes harm to the telephone network, the telephone company will notify you in advance that temporary discontinuance of service may be required. But if advance notice isn't practical, the telephone company will notify the customer as soon as possible. Also, you will be advised of your right to file a complaint with the FCC if you believe it is necessary. The telephone company may make changes in its facilities, equipment, operations or procedures that could affect the operation of the equipment. If this happens the telephone company will provide advance notice in order for you to make necessary modifications to maintain uninterrupted service. If the equipment is causing harm to the telephone network, the telephone company may request that you disconnect the equipment until the problem is resolved.

This equipment is of a type that is not intended to be repaired by the user.

This equipment cannot be used on public coin phone service provided by the telephone company. Connection to party line service is subject to state tariffs. Contact the state public utility commission, public service commission or corporation commission for information.

If your home has specially wired alarm equipment connected to the telephone line, ensure the installation of this DSR 660 does not disable your alarm equipment. If you have questions about what will disable alarm equipment, consult your telephone company or a qualified installer.

We recommend the installation of an AC surge arrester in the AC outlet to which this equipment is connected. Telephone companies report that electrical surges, typically lightning transients, are very destructive to customer terminal equipment connected to AC power sources.

For repair or warranty information, please call: 1-800-531-5000.

Contents

Package Contents	6	Main Menu	
Front and Rear Panels	7	Using the Main Menu	26
Access Card	8	Preferences	27-28
Connections		Preferred Language	27
Antenna and Phone	9	Screen Format	27
Video for TV1	10	Banner Duration	28
Video for TV2	11	Set Favorite Channels	28
Basic configuration	12	Translucency	28
Preparing your Remote Control	13	Parental Controls	29-30
Remote Control Use	13-17	Lock the System	29
Setup Wizard	18	Channel Locks	29
Watching TV	19	Lock Status	29
Enhanced User Features		Set Spending Limit	29
EZ Search PPV	20	Set Rating Limit	30
SmartSurf	20	Replace Access Card	30
Favorite Channels	21	Purchases	31
Program Guide		Setup	32-34
DIRECTV ADVANCED PROGRAM GUIDE™		Output channel TV2	33
.....	22-23	System Upgrades	34
Reminders	23	Messages	35
PPV (Pay Per View)	23	Caller ID	35
Guide Menu	24-25	Troubleshooting	36-37
		Limited Warranty	38

Package Contents



DIRECTV® Multi-Room Receiver



TV1 black Infrared (IR) Universal Remote Control with two AA Batteries

TV2 black Infrared (IR) Universal Remote Control with two AA Batteries



User Manual

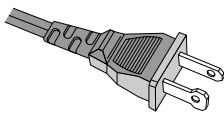

Power Supply Cord



RJ-11 Telephone Cord



TV2 Remote Control Attachment

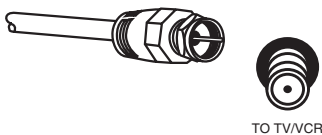

RF Coaxial Cable

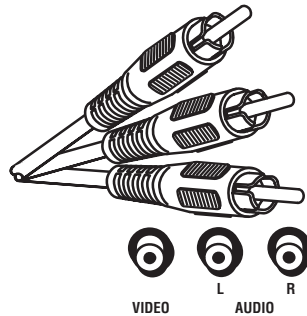

RCA Type Audio/Video Connecting Cable



Access Card

Front and Rear Panels

Front Panel*



TV1 Power indicator
Lights when the TV1 Receiver is on.

TV2 Power indicator
Lights when the TV2 Receiver is on.

OK/MENU button
Confirms a selection in the menus or Program Guide/displays the Main Menu.

Note: On the remote control, Menu and OK are accessed through two distinct keys.

INFO button
Switches between program information in the banner and the program details screen.

*The front panel buttons control TV1 only. To control TV2, use the TV2 remote control.

POWER button
Press to turn the TV1 Receiver on or press to place the TV1 Receiver in Standby.
(For TV2, this function is accessible from the remote control.)

Arrow buttons (◀▶▶▶)
Use to navigate through the Guide and menus.
While watching Satellite programming, use the ▲▼ arrows to channel up or down.

Rear Panel

SAT IN 2
Connect the coaxial cable from the satellite dish antenna. Details on page 9.

Receiver ID Number and Serial Number

RF Output to TV2

AC power input
Connect the supplied power cord here.

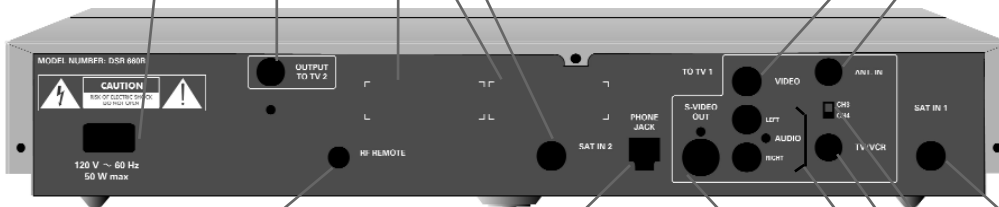

RF Remote Receiver
Connect RF remote control receiver (optional)

Phone jack
Connect the supplied phone cord here and to a wall phone jack in your home.

Video Output (TV1)

Antenna Input
Connect to an off-air antenna or analog cable system.

SAT IN 1
Connect the coaxial cable from the Satellite Dish antenna here. Details are on page 9.

Channel 3/4 switch
Details on page 10.

TV1/VCR RF Output

Left/Right Audio Output (TV1)

S-Video Output (TV1)

Access Card

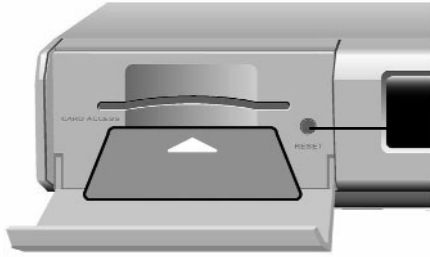

RESET button

Use to reset the receiver.

The access card provided with your system includes information about your purchase authorization and other data. To watch channels, your viewing access card needs to be inserted in the slot on the front of your DIRECTV® Multi-Room Receiver.

The access card needs to be inserted during system setup and generally does not need to be removed. Each access card has a unique number. Be sure to record this number in the space provided on the second page of this manual in the “For Customer Use” section for future reference.

1. Hold the card with the arrow facing upwards and pointing toward the slot in the DIRECTV Receiver front panel.
2. Gently push the card into the slot until it meets the stop. Do not use undue force when inserting. The end will be visible outside of the slot.
3. Keep your access card permanently inserted in your DIRECTV Receiver.

If you have to reinsert the card, you should have the arrow facing forward into the box and the gold chip facing down.



Caution

- YOUR ACCESS CARD IS FRAGILE.
- ALWAYS INSERT CORRECTLY AND CAREFULLY.
- DO NOT BEND.
- DO NOT REMOVE AND RE-INSERT UNNECESSARILY.
- NEVER SUBMERGE IN LIQUID OR APPLY CLEANING FLUIDS.

Connections



Caution

Do not connect your receiver to the AC output before all other equipment is connected.

Antenna and Phone

Unplug all equipment from the AC output before making connections.

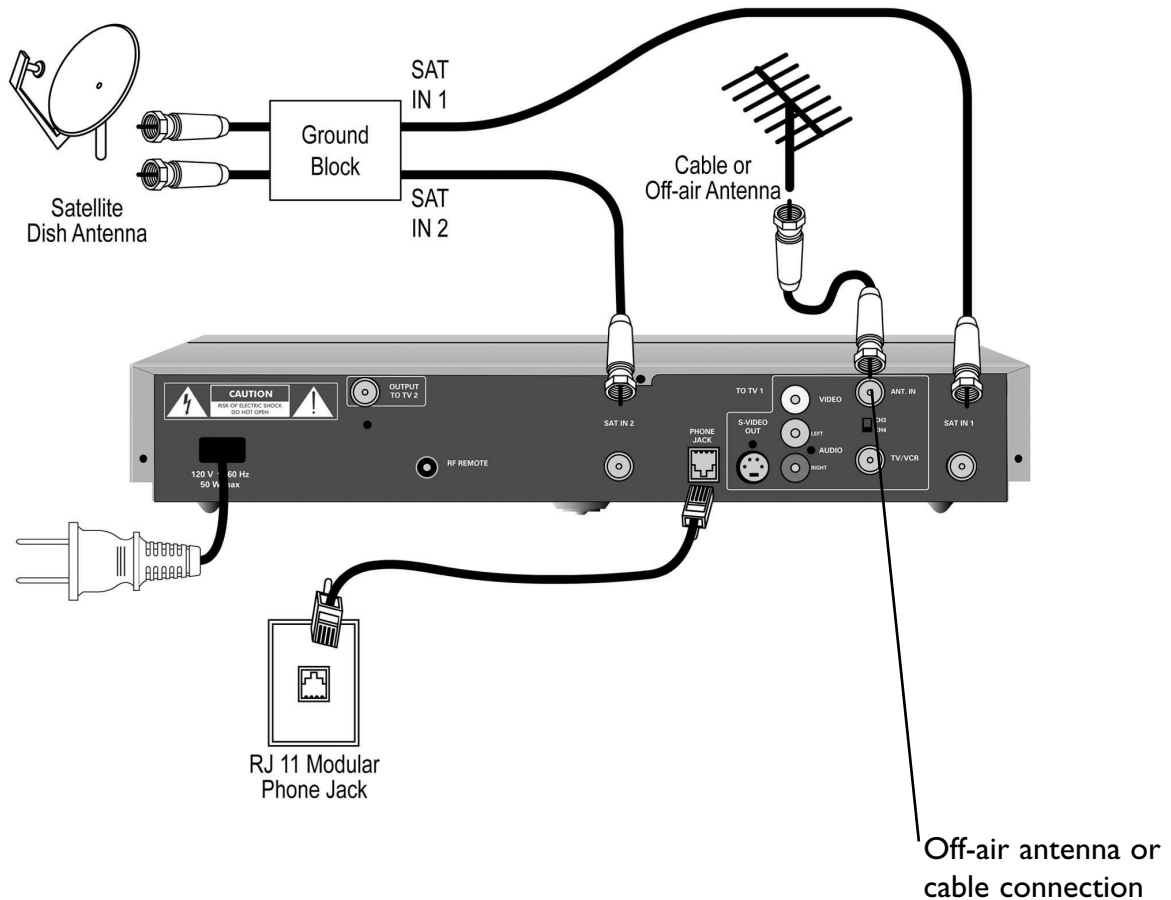

1. Connect two RF coaxial cables from the satellite dish to the SAT IN 1 and SAT IN 2 F-connectors.
2. If you have cable (CATV) or an off-air antenna, connect its RF coaxial cable to the ANTENNA IN jack.
3. Using the telephone cord (supplied), connect one end of it to a phone jack in your home. Connect the other end to the PHONE JACK input on the rear of the DIRECTV® Multi-Room Receiver. To enjoy uninterrupted programming and to order pay per view programs, the Receiver must be continuously connected to a land-based phone line.
4. Connect one end of the AC power cord (supplied) to the Receiver's AC IN jack.

Connections (cont'd)

Video for TV1

Unplug all equipment from the AC outlet before making connections.

There are several options for connecting the video and audio outputs of your DIRECTV® Multi-Room Receiver, depending on the type of equipment you want to connect and the quality of signal you want to achieve. The following chart summarizes your options for video connections. Select either A, B, or C and refer to the illustration and steps below to connect.

Option	Video Signal Quality	Video Output
A	Very Good	S-VIDEO OUT
B	Good	VIDEO
C	Standard	TV/VCR

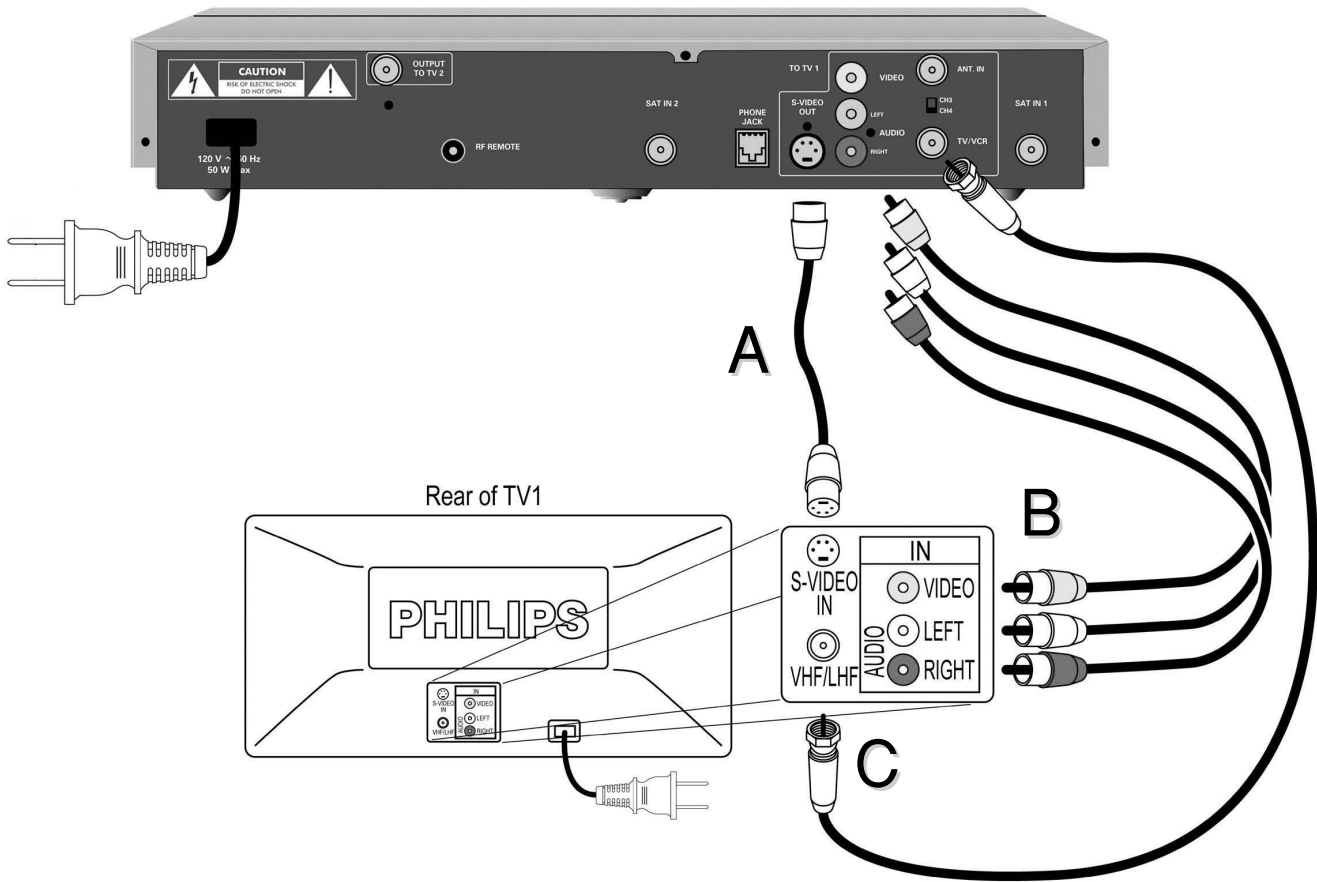

Note: The TV rear jack panel shown above has jacks for all possible connections. Your TV's rear jack panel may differ.

- A.** Using a S-VIDEO cable, connect one end to the S-VIDEO OUT jack on the Receiver to the S-VIDEO IN on the TV. Select the proper input on your TV.
- B.** Using the RCA type connector (supplied), connect one end to the VIDEO jack (yellow) on the Receiver to the VIDEO IN on the TV. Select the proper input on your TV.
- C.** Using the RF coaxial cable (supplied), connect one end to the TV/VCR jack on the Receiver to the RF IN jack on the TV. Turn the TV on and select channel 3 or 4, whichever is not used or least used in your area. Set the CHANNEL switch on the back of the Receiver to the same channel.

Connections (cont'd)

Video for TV2

Unplug all equipment from the AC output before making connections.
The following chart shows the recommended basic installation.

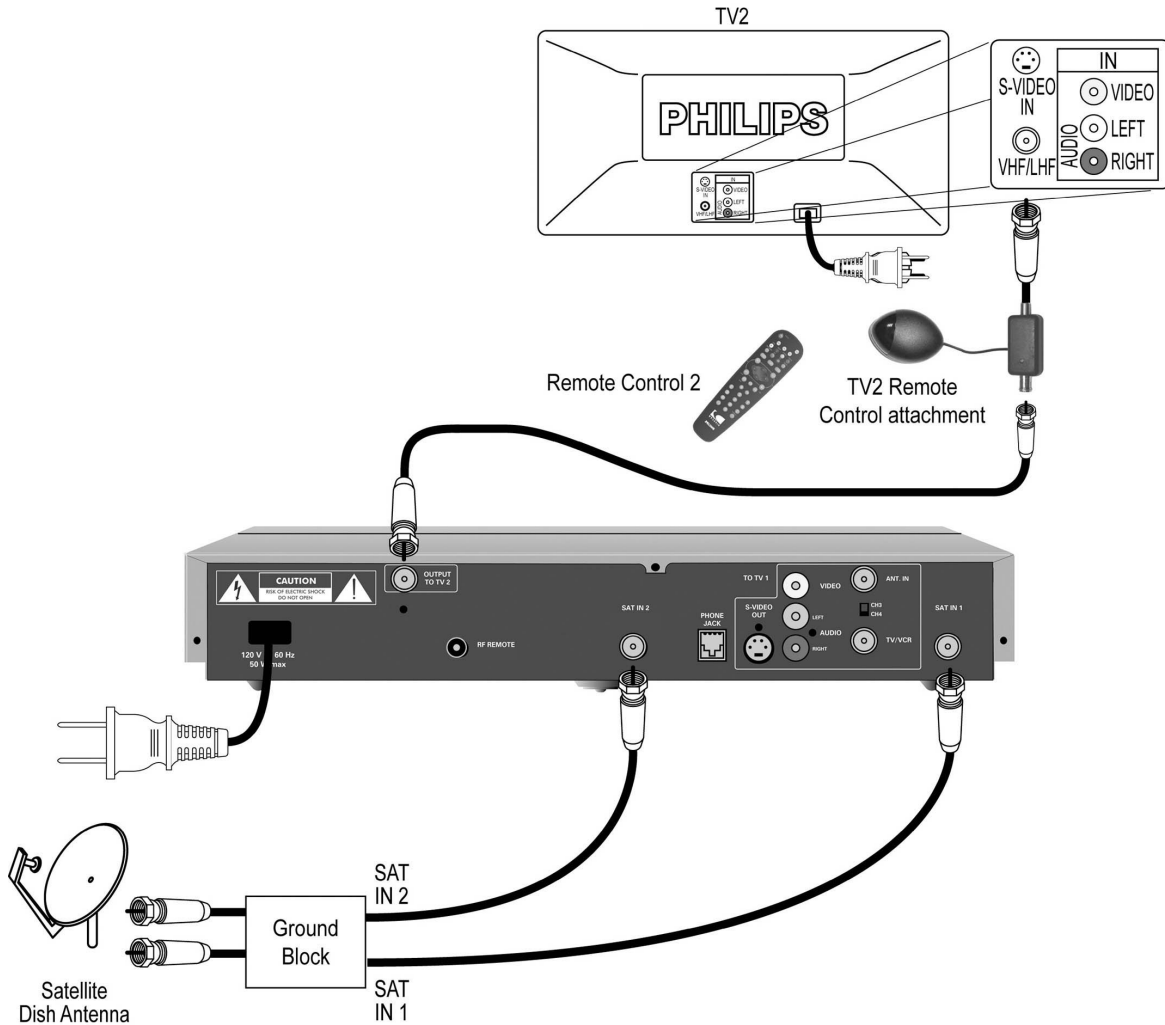

Notes:

This illustration shows standard configuration. For more information about other installation options, please call 1-800-531-5000.



Caution

Always connect the Multi Room Receiver exactly as indicated in this manual.

The "OUTPUT TO TV2" jack on the Multi Room Receiver must always be connected to the TV2 Remote Control Attachment. The TV2 Remote Control Attachment is then connected to antenna input jack on TV2.

NEVER CONNECT THE MULTI ROOM RECEIVER DIRECTLY TO TV2. IT MUST ONLY BE DIRECTLY CONNECTED TO THE TV2 REMOTE CONTROL ATTACHMENT. FAILURE TO PROPERLY CONNECT THIS PRODUCT COULD DAMAGE YOUR TV SET.

Connections (cont'd)

Basic configuration

Unplug all equipment from the AC output before making connections.

There are several options for integrating your DIRECTV® Multi-Room Receiver in your setup. The following chart shows the recommended basic installation.

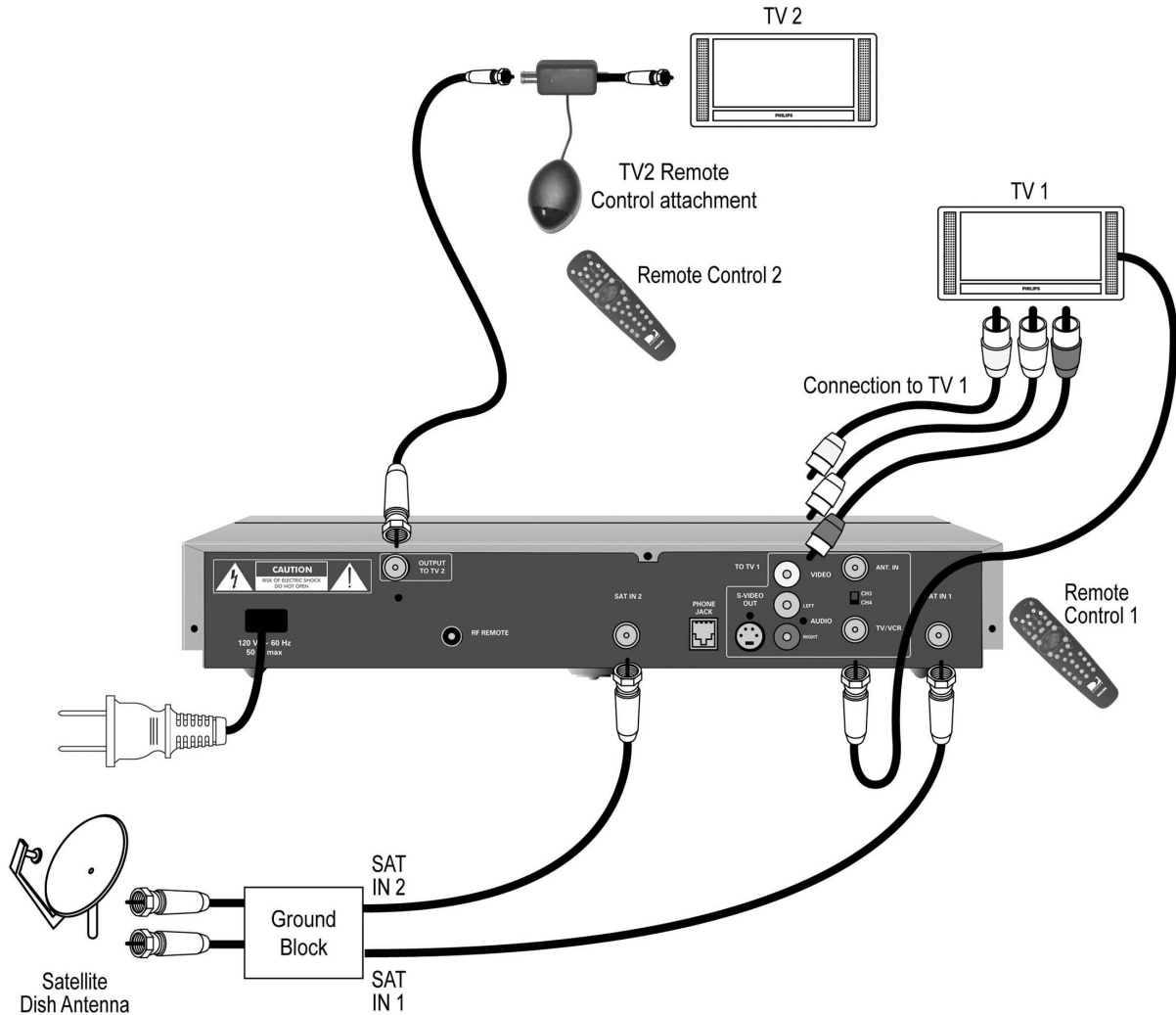

Notes:

This illustration shows standard configuration. For more information about other installation options, please call 1-800-531-5000.



Caution

Always connect the DIRECTV® Multi Room Receiver exactly as indicated in this manual. The “OUTPUT TO TV2” jack on the Multi Room Receiver must always be connected to the TV2 Remote Control Attachment. The TV2 Remote Control Attachment is then connected to antenna input jack on TV2.

Remote Control

Preparing Your Remote Control

Battery Installation

1. Remove the battery compartment cover. Insert the two batteries (type/AA) supplied.
2. Position them in the battery compartment, as shown in the diagram.
3. Replace the cover.

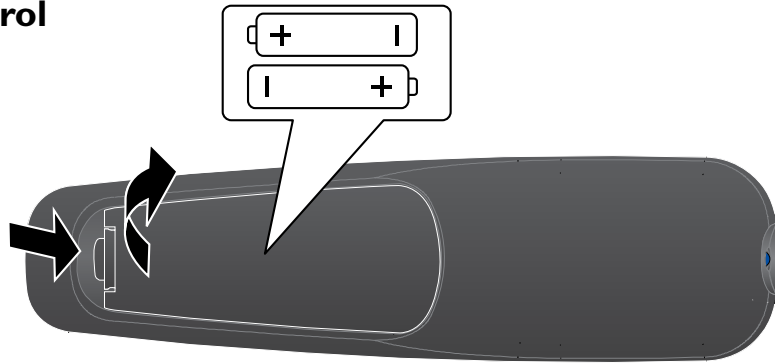

Satellite Functions

SAT

Press SAT to control the DIRECTV® Multi-Room Receiver. LED will blink when other buttons are pressed while in satellite mode.

PPV

Use the EZ Search PPV function to view list of PPV programs and events for purchasing.

SOURCE

Inactive key

MENU

Displays the Main Menu.

EXIT

Returns to video and cancels the transaction.

INFO

Displays program or channel information.



Navigates through the Guide and menus.

0-9

Lets you enter numeric values or channel numbers.

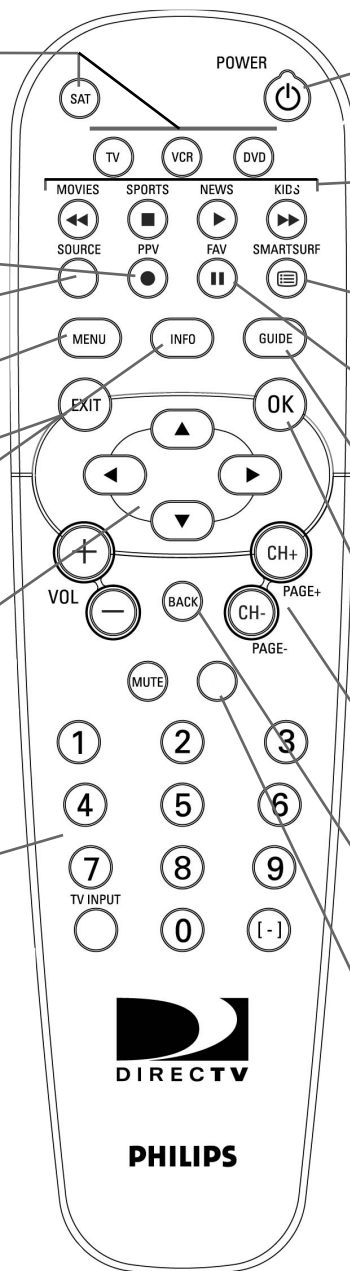

POWER

Switches the DIRECTV® Receiver between active and standby modes.

MOVIES, SPORTS, NEWS, KIDS

Predefined SmartSurf buttons (refer to page 20).

SmartSurf

Displays categories you can use for Guide and channel surfing.

FAVORITES

Allows you to select one of four custom lists to view or edit.

GUIDE

Switches between the "DIRECTV ADVANCED PROGRAM GUIDE™" and the "Guide Menu".

OK

Confirms a selection.

CHANNEL

Displays the next or previous channel. While in the guide or menu, allows you to page up and down.

BACK

While in the menu or guide, returns you to the previous screen. While watching TV, pressing BACK will jump you to the previous channel.

Inactive key

Remote Control (cont'd)

Programming the Universal Remote control

Your remote control **may** already operate your TV, VCR or DVD player. If the remote control does not properly operate your TV, VCR or DVD player, follow the steps below. These instructions guide you through setting the remote control to operate your TV. For VCR and DVD player, follow the same steps, but press the VCR or DVD button at step 3.

1. Point the remote control at your TV and press the TV button. Then, press the POWER button. If your TV turns on or off, try the other TV function buttons (see page 16). If the other functions work, the remote is ready to operate the TV without any more steps. If your TV does not turn on or off, or if the other buttons do not work, go to step 2.
2. Find the brand and code number(s) of your TV on page 15.
3. Press the TV button.
4. Press and hold the number 1 and number 3 buttons simultaneously for 3 seconds. The LED will blink twice and remain on.
5. Enter the 4-digit code from step 2 within one minute. The LED will blink after each button press. Note: If the 4-digit code is not entered within one minute, the LED will turn off and the remote control will return to the previously programmed code.
6. After a valid 4-digit code has been entered, the LED will turn off and blink twice to confirm the new 4-digit code has been programmed. The LED will then turn off.
7. If an invalid 4-digit code has been entered, the LED will turn off.
8. Press the POWER button. If the remote control operates your TV, you're finished.
9. If the remote control doesn't operate your TV and if there is more than 1 code for your TV brand, repeat steps 2-8.
10. For future reference, list the 4 digit code numbers you program into your remote:
TV code: ___ ___ ___ ___
VCR code: ___ ___ ___ ___
DVD code: ___ ___ ___ ___
11. If you cannot find a code that operates your TV, if the remote still does not operate your TV, follow the Automatic Search steps below.

Automatic Search

To automatically program your remote control to operate your TV, VCR or DVD player, follow the steps below. For a VCR and DVD player, follow the same steps but substitute that component for the TV.

1. Turn on your TV. Stand close to your TV (within 5 to 10 feet) and point your remote control towards the remote sensor on your TV. Press the TV button. Press and hold the number 1 and the number 3 buttons simultaneously for 3 seconds. The TV LED will blink twice and remain on.
2. Press the POWER button. The LED will turn off. If the POWER button is not pressed within 1 minute, the remote will return to the previously programmed code. The automatic search will begin after the POWER button has been released.
3. Each time a code is transmitted, the LED will blink. This process could take several minutes.
4. When the correct code is found, the TV should turn off. Immediately press the POWER button. The LED will blink twice, then turn off. If all codes have been tried and the TV has not turned on or off the LED will stay on briefly, then turn off.

Note: To stop the search process at any time, press any button other than the POWER button. The LED will give a long blink and turn off. There is no guarantee that the remote control will work with your TV, VCR or DVD player.

Remote Control (cont'd)

TV Codes

AOC.....0046, 00570490, 0204, 0309, 0066, 0046, 0181	Midland0044, 0066, 0074, 0078, 0162, 0774	Sansui.....0490
Admiral0120, 0490	Envision0057	Minutz0048	Sanyo0181
Aiko0119	Fisher0181	Mitsubishi0177, 0205, 0046, 0120	Scimitsu0046
Alkai0057	Fujitsu0206, 0710	Motorola.....0120	Scotch0205
Alaron0206	Funai0207, 0198, 0206	Multitech.....0207	Scott0263, 0046, 0205, 0206, 0207
Ambassador0204	Futurtech0207	NAD0183, 0193, 0205	Sears0181, 0083, 0183, 0074, 0081,
America Action0207	GE0048, 0074, 0078, 0205, 0478,	NEC0057, 0046, 00830198, 0205, 0206, 0774
Ampro07780120, 0162, 0309, 0774	NTC0119	Semivox.....0207
Anam0207	Gibraltar.....0044, 0046, 0057	Nikko.....0205, 0057, 0119	Semp0183
Audiovox0119, 0207, 0478	GoldStar0205, 0046, 0057, 0083	Onwa0207	Sharp0120, 0192, 0066
Baysonic0207	Gradiente0083, 0080	Optimus0277, 0193, 0181	Shogun.....0046
Belcor0046	Grunpy0206, 0207	Optonica0120, 0192	Signature.....0043
Bell & Howell0043, 0181	Hallmark0205	Orion0490, 0206, 0263	Sony0207
Bradford0207	Harley Davidson0206	Panasonic.....0078, 0277	Soundesign0205, 0206, 0207
Brockwood.....0046	Harman/Kardon0081	Penney0074, 0087, 0057, 0048, 0162,	Squareview0198
Broksonic0263, 0490	Harvard02070205, 0078, 0066, 0046, 0083, 0183, 0774	Starlite0207
CXC0207	Hitachi0172, 0178, 0083, 0043	Philco0172, 0046, 0057, 0081, 0490	Supreme0027
Candle0057, 0083	Infinity0081	Philips0081	Sylvania.....0081, 0057
Carnivale.....0057	Inteq0044	Pilot0046, 0057, 0066	Symphonic0198
Carver0081	JBL0081	Pioneer0193	TMK0083, 0204, 0205
Celebrity.....0027	JCB0027	Portland0046, 0066, 0119	Tandy0120
Cineral0478, 0119	JVC0080	Prism0078, 0277	Technics0078, 0277
Citizen.....0083, 0057, 0066, 0087, 0119	KEC0207	Proscan0074, 0774	Technol Ace0206
Concerto0083	KTV0207, 0057, 0066	Proton0205	Techwood0078, 0083
Contec0207	Kenwood0057, 0046	Pulsar0044, 0046	Teknika0043, 0081, 0206, 0207,
Craig0207	LG0083	Quasar0078, 0277, 01920046, 0066, 0119, 0083, 0087, 0177
Crosley0081	LXI0181, 0074, 0081, 0183, 0205, 0774	RCA0074, 0162, 0046, 0078, 0117,	Telefunken0083
Crown0066, 0207	Logik00430120, 0774	Toshiba0183, 0087, 0181
Curtis Mathes0087, 0057, 0043,	Luxman0083	Radio Shack0192, 0207, 0057, 0205,	Television0066
.....0066, 0074, 0078, 0081, 0083, 0120,	MGA0177, 0046, 0057, 02050066, 0181, 0046, 0074, 0083, 0774	Vector Research0057
0172, 0181, 0193, 0478, 0774	MTC0087, 0057, 0046, 0083	Realistic0192, 0207, 0181, 0057, 0066,	Victor0080
Daewoo0119, 0046, 0478, 0066	Magnavox0081, 0057, 02060205, 0046, 0083	Vidikron0081
Daytron0046	Majestic0043	Runco0044, 0057	Vidtech0046, 0205
Denon0172	Marantz0081, 0057	SSS0046, 0207	Wards0081, 0192, 0205, 0043,
Dumont0044, 0046	Matsushita0277	Sampo0057, 00660046, 0048, 0057, 0083, 0206
Dwin0747, 0801	Megatron0172, 0205	Samsung0087, 0046, 0205, 0057, 0083	White Westinghouse0490
Electroband0027	Memorex0205, 0043, 0083, 0177,	Samsux0066	Yamaha0046, 0057
Emerson0263, 0207, 0205, 0206,0181, 0277, 0490	Sansei0478	Zenith.....0044, 0043, 0119, 0490

VCR Codes

Admiral0075, 0236	Funai0027	Minolta0069	Samsung.....0072, 0267
Adventura.....0027	GE0062, 0087, 0075, 0267, 0787	Mitsubishi0070, 0075, 0094	Sanky0066, 0075
Aiko0305	Garrard0027	Motorola0062, 0075	Sansui0068, 0027, 0094, 0236, 0298
Aiwa0334, 0027, 0064	Go Video0553	Multitech.....0027, 0099	Sanyo0074, 0073, 0131, 0267
Alkai0133, 0068	GoldStar0064, 0065	NEC0065, 0068, 0094, 0131	Scott0211, 0148, 0070, 0072
America Action0305	Gradiente0027	Nikko0064	Sears0064, 0069, 0027, 0062, 0073,
American High0062	HI-Q0074	Noblex02670074, 0131
Asha0267	Harley Davidson0027	Olympus0062	Semp0072
Audiovox0064	Harman/Kardon0065, 0108	Optimus0189, 0075, 0064, 0131	Sharp0075
Beaumarck0267	Headquarter0073	Orion0029, 0211, 0236	Shintom0099
Bell & Howell0131	Hitachi0069, 0027, 0068	Panasonic.....0062, 0189, 0252, 0643	Shogun.....0267
Broksonic0148, 0211, 0029, 0236	Hughes Network Systems.....0069	Penney0062, 0267, 0064, 0069, 0065	Singer0099
CCE0099, 0305	JVC0094, 0068	Pentax0069	Sony0060, 0059, 0027, 0062
Calix0064	Jensen0068	Philco0062, 0236	Sylvania0062, 0108, 0027, 0070
Canon0062	KEC0064, 0305	Philips0108, 0062, 0645	Symphonic0027
Capehart.....0047	KLH0099	Pilot0064	TMK0267
Carver0108	Kenwood0068, 0094, 0065	Pioneer0094	Tatung0068
Cineral0305	Kodak0062, 0064	Portland0047	Teac0027, 0068
Citizen0305, 0064	LXI0064	Profitronic0267	Technics0062, 0189
Colt0099	Lloyd's0027	Proscan0087, 0787	Teknika0027, 0062, 0064
Craig0064, 0099, 0074, 0267, 0298	Logik0099	Protec0099	Thomas0027
Curtis Mathes0062, 0068, 0087, 0189,	MEL0062	Pulsar0066	Tivo0645
.....0787	MGA0070, 0267	Quarter0073	Toshiba0072, 0070
Cybernex0267	MGN Technology0267	Quartz0073	Totevision0064, 0267
Daewoo0305, 0588, 0047, 0072	MTC0027, 0267	Quasar0062, 0189	Unitech0267
Daytron0047	Magnasonic.....0305	RCA0087, 0176, 0069, 0062, 0075,	Vector0072
Denon0069	Magnavox.....0062, 0108, 0027, 0066, 01760133, 0267, 0787	Vector Research0065
Dynatech0027	Magnin0267	Radio Shack0027	Video Concepts0072
Electrohome0064	Marantz0108, 0062	Radix0064	Videosonic0267
Electrohome0064	Marta0064	Randex0064	Wards.....0062, 0087, 0027, 0074, 0267,
Emerex0059	Matsushita0062, 0189	Realistic0027, 0131, 0074, 0075,0069, 0075, 0099, 0108, 0176, 0787
Emerson0211, 0029, 0236, 0305, 0148,	Memorex0131, 0074, 0027, 0064,0064, 0062, 0073	White Westinghouse0305, 0236
.....0588, 0027, 0064, 00700075, 0062, 0073, 0267, 0334, 0066,	ReplayTV0641, 0643	XR-10000099, 0027, 0062
Fisher0074, 01310189, 0236	Runco0066	Yamaha0065
Fuji0060, 0062		STS0069	Zenith.....0066, 0027, 0060, 0236

DVD Codes

Aiwa0668	Hitachi0600, 0691	Oritron0678	Sharp0657
Apex0699	Hiteker0699	Panasonic0517, 0704, 0659	Sherwood0660
Arcam0759	JVC0650, 0585	Pelican Accessories0758	Sony0560
B & K0682, 0689	Kenwood0764, 0709, 0561	Philips0566, 0530	Technics0517
Denon0517, 0661	Konka0746, 0738, 0747, 0748	Pioneer0598, 0552, 0659	Techwood.....0719
Fisher0697	Magnavox.....0530, 0702	Princeton0701	Theta Digital0598
GE0549	Marantz0566	Proscan0549, 0598, 0731	Toshiba0530
Go Video.....0742	Mitsubishi0548	RCA0549, 0598, 0731	Yamaha0517, 0572
Gradiente0678	Onkyo0654, 0530	Saitek0758	Zenith.....0618, 0530
Harman/Kardon0609, 0729	Optimus0598	Samsung0600	

Remote Control (cont'd)

TV Functions

Once programmed (refer to page I4), your DIRECTV® Remote Control should control certain functions of your TV. Be sure to press the TV button before operating your TV.

TV

Press to put the remote control in TV mode. LED will blink when other buttons are pressed while in TV mode.

POWER

Press to turn TV on or off.

VOL +/-

Increases and decreases volume.

MUTE

Switches audio on and off.

0-9

Allows direct number entry for tuning to a channel.

TV INPUT

Switch through TV inputs (if applicable).

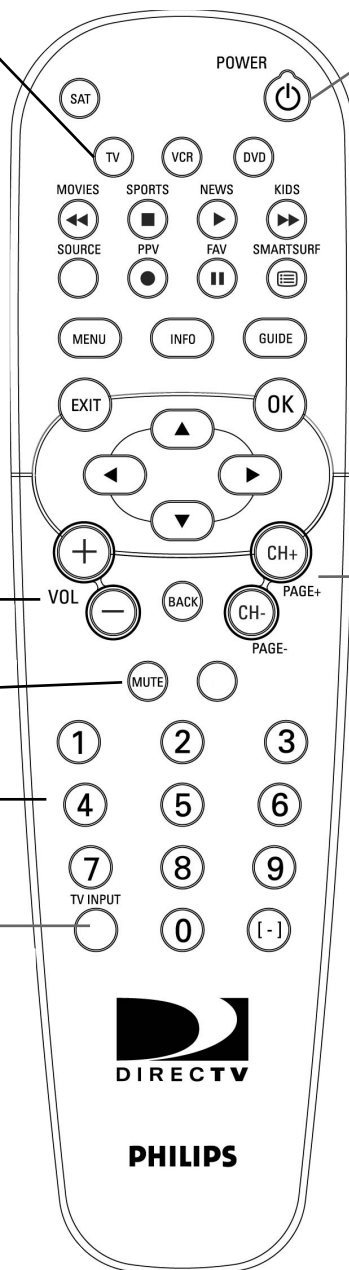

CH+/CH-

Change channel up or down

Note: All features on your TV may not be supported by this remote.

Remote Control (cont'd)

VCR/DVD Functions

Once programmed (refer to page 14), your DIRECTV® Remote Control should control certain functions of your VCR or DVD. Be sure to press the VCR or DVD button before operating each unit.

VCR

Press to put the remote control in VCR mode. LED will blink when other buttons are pressed while in VCR mode.

REWIND

VCR - When tape playback is stopped, press to rewind at high speed. During tape playback, press to rewind the tape while the picture stays on the screen.

DVD - Press and release to select previous chapter. Press and hold to scan backwards.

STOP

Press to stop the tape or disc.

RECORD (VCR only)

Press once to start a recording.

0-9

Allows direct number entry for tuning to a channel or chapter.

POWER

Press to turn VCR or DVD player on or off.

DVD

Press to put the remote control in DVD mode. LED will blink when other buttons are pressed while in DVD mode.

FF

VCR - When tape playback is stopped, press to advance the tape at high speed. During tape playback, press to advance the tape while the picture stays on the screen.

DVD - Press and release to select next chapter. Press and hold to scan forward.

PLAY

Press to play a tape or disc.

PAUSE

Press to pause a tape or disc.

CH+/CH- (VCR only)

Change channel up or down

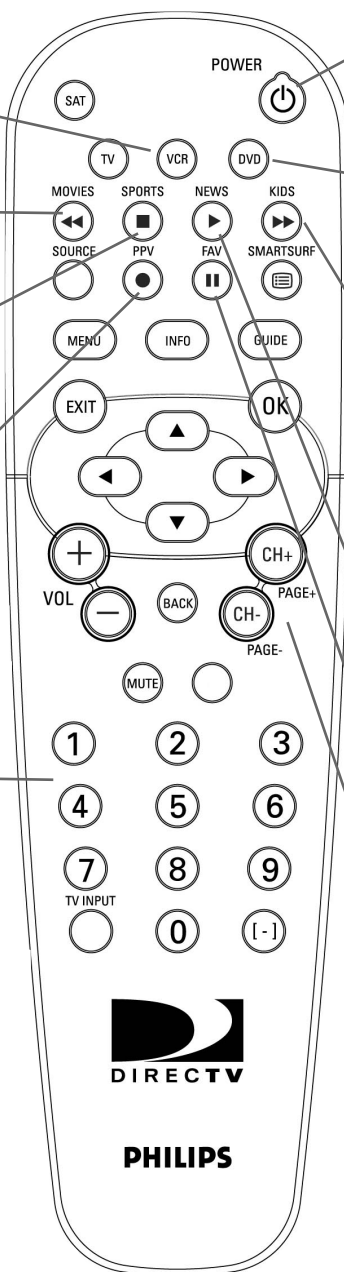

Note: All features on your VCR or DVD player may not be supported by this remote.

Setup Wizard

If your equipment has been professionally installed, skip this first time setup section and go to page 19.

After the DIRECTV® Multi-Room Receiver has been connected to your components, it is time to turn the DIRECTV Receiver on.

1. Connect your receiver to the AC output.
2. The Select preferred language menu appears.
3. Use the ▲▼ buttons to select your preferred language of the on screen menus and guide and press OK.
4. When the Welcome screen displays, press the OK button on the remote control to start the Setup Wizard. The Setup Wizard is a first time setup that automatically steps you through the installation process. This screen will **ONLY** appear the very first time your DIRECTV Receiver is turned on.
 - a. Enter the ZIP code.
Note: The ZIP code is critical to point your dish accurately (refer to page 32).
 - b. Configure the dish (refer to page 32).
 - c. Point the dish (refer to page 32).
 - d. Test the System (refer to page 33).
5. After you have installed your DIRECTV System, you should contact DIRECTV to order DIRECTV® programming at 1-800-531-5000.

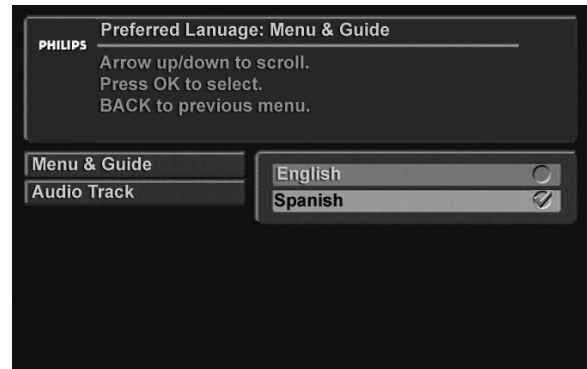

Important note

Some of the menu and/or option screens, such as Setup, Parental Controls, Editing a favorite list, or Messages, cannot be accessed simultaneously from TV1 and TV2. If you try and access one while it is being used at the other TV, a warning will be displayed.

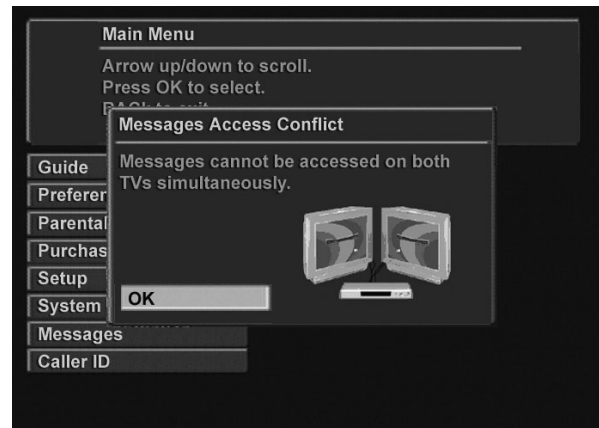

Messages Access Conflict screen

Watching TV

The Info Banner shows information on the currently tuned program such as the rating, title, start and end time, program description, and channel number. It also displays the current time and date and indicates if any special features are currently enabled, such as Favorite Channels (page 21) or SmartSurf (page 20). It is only reflective of the TV being watched.

All Day Ticket (Pay Per View)	Letterbox format
Alternate Audio Track	System Locked
Closed Captioning	System Temporarily Unlocked
New Incoming Messages	Pay Per View

Channel Number & Name

Start/End Time & Date

Channel Icon

Program Name & Description

On Screen Display (OSD) message space indicates error messages or status or song ID information (when you select a channel that contains audio only).

Rating

Current Time & Date

Current Alternate Audio Track

- The alternate audio icon indicates an alternate audio track is available. To change audio tracks, press the ◀ or ▶ button on the remote.

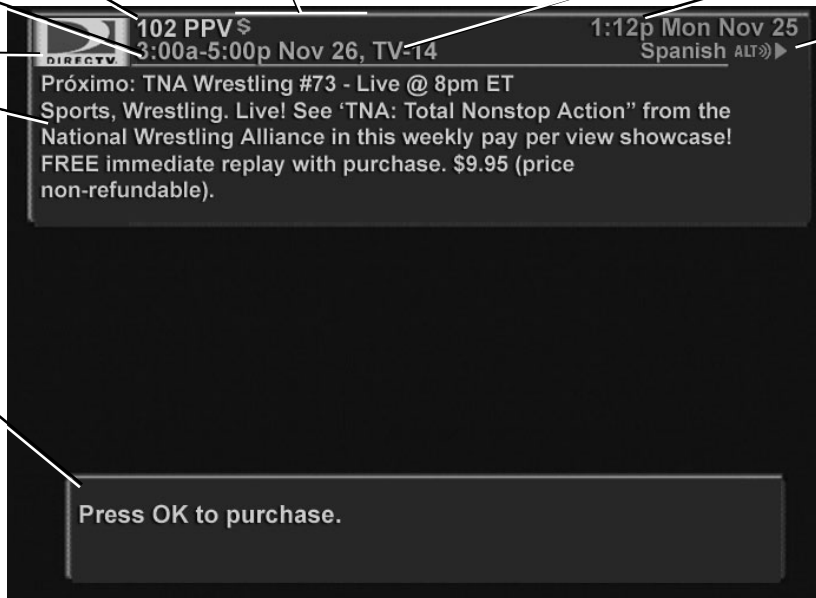

Watching TV

To do this....

Do this....

Display the banner

Press INFO button on the remote.

View program details

1. Press INFO to display the banner.
2. Press INFO again to display program details.

View other channels with the Browse Banner

- You can see or “browse” what is on other channels without tuning away from the currently viewed program with the Browse Banner.
1. While watching a program, press the INFO button on the remote to display the banner.
 2. While the banner is displayed, press the ▲▼ buttons to see what is showing on other channels.
 3. Press OK to switch to the new channel displayed in the Banner or exit to remove the banner.

Note: When Favorite Channels (page 21) or SmartSurf (page 20) is in use, the Browse Banner will only show programs from those lists.

Enhanced User Features

EZ Search Pay Per View (PPV)

Philips offers a unique feature for searching pay per views. By pressing the PPV button on the remote, a listing of all pay per view programs starting within a chosen time period will be displayed alphabetically.

1. Press the PPV button on the remote.
2. Use the ▲▼ to select a time period to search in (Note: The full 3.5 day search takes about 10 seconds and cannot be interrupted) and press OK.
3. Use the ▲▼ to select a pay per view program and press OK. View details about your selected pay per view program, purchase it or display other showings of your selection.

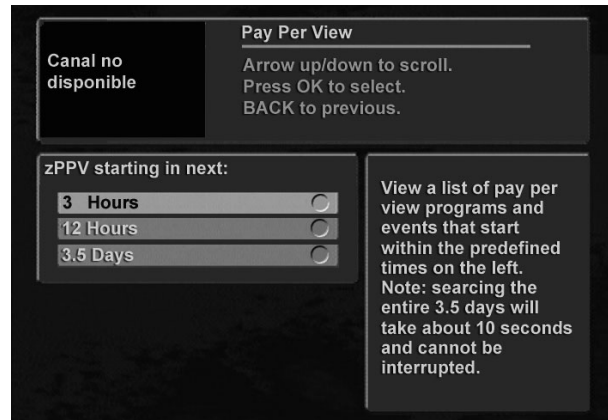

Select time period for pay per view search

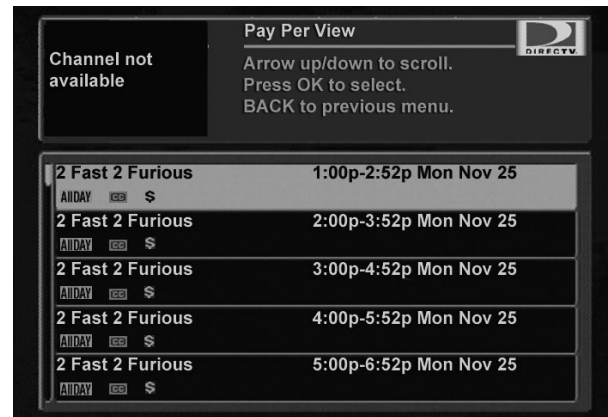

List of pay per views starting within chosen time period

SmartSurf™

SmartSurf Choosing SmartSurf is an easy way to highlight the programs whose categories or themes match your choice in the guide. Also, when changing channels, you will go only to the channels containing programs that have the selected category. When SmartSurf is active, the SmartSurf icon displays in the lower right-hand corner of the banner.

There are four pre-defined SmartSurf categories. Refer to the buttons on the remote.

Pre-defined Smartsurf icons:



Movies Sports News Kids

To select specific SmartSurf category:

1. Press SmartSurf on the remote control. You have a choice to clear an existing setting (if active already), cancel, or continue with setting the SmartSurf.
2. Press the ▲▼ buttons to highlight the desired category or subcategory. The presence of subcategories is indicated by an arrow to the right of the category. To view the subcategories, press the ► button.
3. Press OK to select the category or subcategory.

Note: To turn off SmartSurf, press any of the SmartSurf keys, select "Clear SmartSurf", and press OK. When the POWER button is pressed and the receiver goes into standby, SmartSurf is automatically turned off.

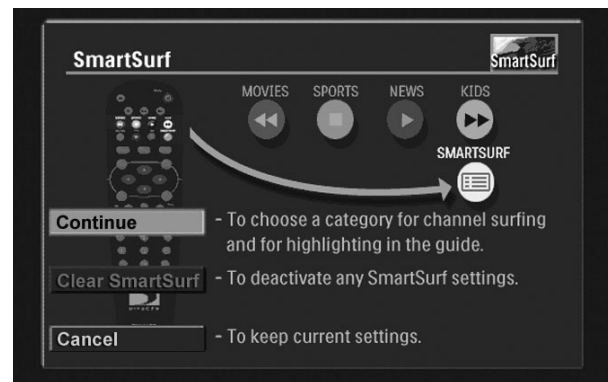

SmartSurf options

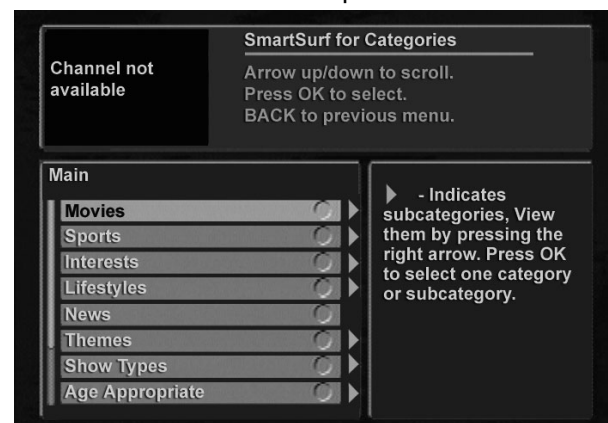

List of categories for SmartSurf

Enhanced User Features (cont'd)

Favorite Channels



Favorite Channels is an easy way to customize the listing of channels. Once Favorites is configured, the Favorites icon displays in the banner and programs displayed in the Program Guide are only those in the selected list. **When using the CH+ and CH- buttons, you are limited to channels in the Favorites list;** however, you can access any channel by entering its number directly on the remote control. Favorites lists are shared between both TVs. You can save up to four different favorite channel lists. This way, members of a household can each set their own favorite channel list.

To access Favorite Channels:

1. Press FAV (FAVORITES) on the remote.

Or from the Main menu:

1. Press MENU.
2. Use the ▼ button to select “Preferences” and press OK.
3. Use the ▼ button to select “Set Favorite Channels” and press OK.

Then, to select or edit a Favorite channel list:

1. Press the ▲▼ buttons to highlight the desired list, and press OK. Or, to turn off any previously selected Favorites list, highlight “All Channels”, and press OK.
2. Then, use the ▲▼ buttons to highlight “Select” to activate your Favorite list and press OK. Or, to edit the name or customize a Favorite channel list, select “Select and Edit” and press OK.

Note: You cannot edit the same Favorite list simultaneously from both TVs. If a given list is being viewed on the other TV and you make an attempt to edit it from the other, a conflict message is displayed.

Select & Edit: Change List Name:

1. Select “Change List Name” and press OK.
2. Use the ◀▶▲▼ buttons to scroll through the alphabet. When the letter you want is selected, press OK. Repeat until you have spelled the list name.
3. When finished, select “Done” on the on-screen keyboard and press OK.

Select & Edit: Customize Favorites:

1. Select “Customize Favorites” and press OK.
2. You can manually select/deselect channels by highlighting a channel and pressing OK. Use the ▲▼ buttons to navigate through the list, or use the PAGE +/- buttons to scroll the list up or down by a complete page.

“Select All” selects all channels in the list. You can then manually deselect any channel.

“Deselect All” deselects all the channels in the list. You can then manually select any channel.

3. When customization is complete, select “Save Changes” and press OK. Press BACK to return to the previous menu without saving your changes.

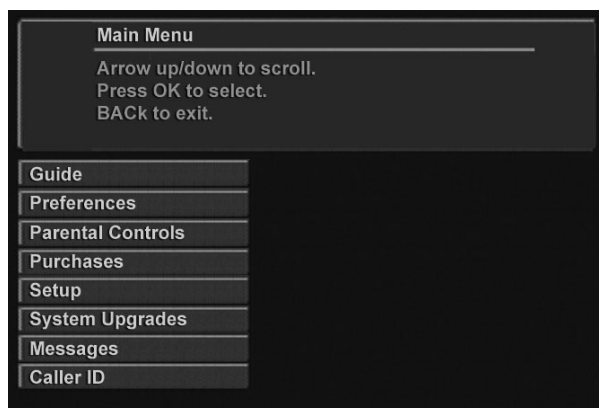

To access Favorites from the Main Menu, press MENU and select “Preferences”

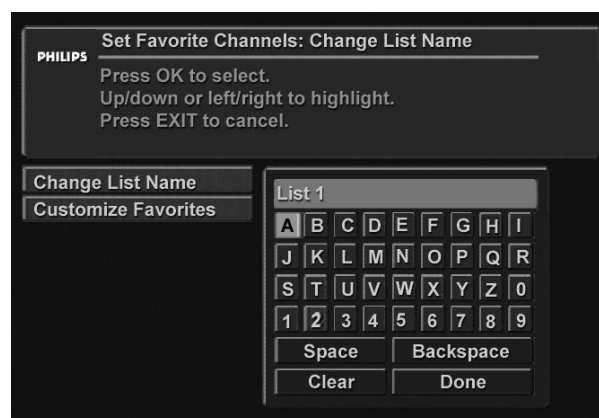

Select “Set Favorite Channels” in the “Preferences” menu

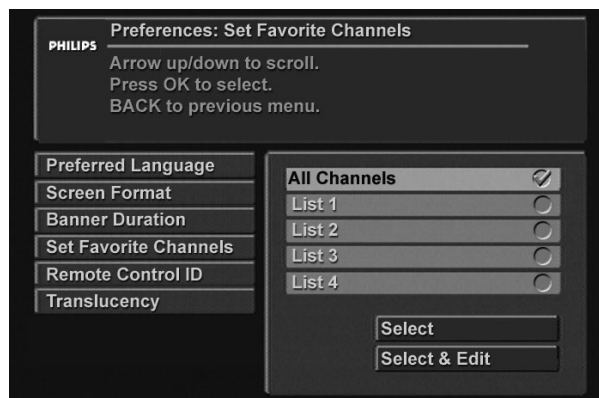

Change List Name

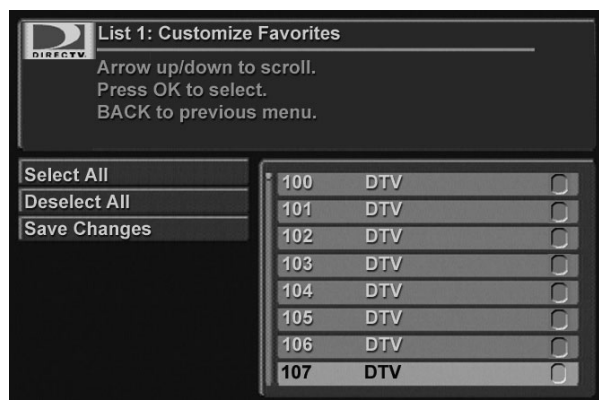

Customize Favorites

DIRECTV ADVANCED PROGRAM GUIDE™

DIRECTV ADVANCED PROGRAM GUIDE

The DIRECTV ADVANCED PROGRAM GUIDE offers complete TV listings for up to 3 1/2 days plus access to much more. The Guide lists programs according to their time slot and channel. With it, you can tune to a program, be notified when a program is about to start, order pay per view programs, search through listings by the type of program you're looking for, and set reminders for future viewing.

The **Channel Scroll Bar** shows the position of the channel relative to the total number of channels.

The **Channel List** shows the channels available.

Arrows indicate that the program extends beyond the time slot shown.

The **Clock** indicates that a Reminder for the program has been set for future viewing. If a Reminder is set, it will always display in the Guide cell. You will get notification before the program starts so that you can tune to it.

The **Program List** shows all the programs airing in a given time slot. If program names are too long to fit into a guide cell, they may be shortened. When a program is selected, its full name appears in the banner.

The **Banner** in the guide shows information on the highlighted program such as the rating, title, start and end time, program description, and channel number. It also displays the current time and date and indicates if any special features are currently enabled, such as Favorite Channels (page 21) or SmartSurf (page 20).



Using the Guide

To do this....	Do this....
Display the Guide	Press the GUIDE button on the remote control or select "Guide" from the Main Menu.
Scroll through the Program List	Press the ▲▼ buttons. You can use the PAGE+/- buttons to scroll a full page at a time.
Scroll to another time slot	Press the ◀▶ buttons. Program information displays in the banner.
Choose a program to view	Press the arrow buttons until the program you want to view is highlighted in the Guide. If the program is in the current time slot, pressing OK tunes to the selected channel and displays the information for the program in the banner. If the program is in a future time slot, you are given the option to set a Reminder (refer to page 23). If the selected future program is pay per view, you are also given the option to purchase the program.
View program details	You can toggle between the guide and program details by pressing the INFO button on the remote.

DIRECTV ADVANCED PROGRAM GUIDE™ (cont'd)

Using the Guide (cont'd)

To do this....

Do this....

Set a Reminder for future viewing



You can set up your viewing schedule ahead of time, so that you will be automatically notified of the shows you want to see. In the Guide, Reminders display as a clock to the right of the program title. Reminders must be set for each TV respectively. If you wish to record a program using your VCR, set the VCR's timer recording also. Refer to your VCR's owner's manual for timer recording instructions. The DIRECTV® Multi-Room Receiver will turn on at the correct time and tune to the channel if a Reminder is set.

To set a Reminder for a non-pay per view program

1. Highlight a future program in the guide and press OK. In the Reminder screen, choose whether you want to select this program once, daily, weekly, or Monday-Friday. Remember, you are actually setting the Reminder by the time slot, so if the program moves to a different time slot, you will need to reset the Reminder.
2. Press OK.

If the program is in the same time slot as another Reminder, the system will prompt you that a conflict exists.

To set a Reminder for a pay per view program

1. When a future pay per view is purchased, you are given the option to set a Reminder in the purchase details screen. If you set the Reminder for a purchased pay per view, you will be charged when the event airs.

To cancel a Reminder for a program

1. Highlight the program in the guide and press OK.
2. Choose "Once" if you want to cancel a Reminder program for one time slot only, or "Always" if a program has been set as a Reminder more than once, for example, a program that airs every day. Then, press OK.

PPV (Pay Per View)

Pay per view programs include special programming, movies, and sporting programs and are indicated by a "\$" in the banner. In the Guide, you can preview currently airing PPV programs, purchase current and future PPV programs, and cancel a purchase. From the Main Menu, you can view the purchase history, cancel purchases, and restrict this feature by setting rating and spending limits. PPV programs are available on both TVs.

To purchase a PPV program:

1. Highlight the program in the Guide and press OK.
2. Select "Buy" and press OK. The price will display on the button. If you have locked your DIRECTV Receiver and the rating or spending limit is exceeded, you must enter your access code to temporarily unlock the receiver (refer to page 29) before you can purchase it.
3. Select "Showings" to see a list of alternate show times. Press the ▲▼ buttons to move to the next selectable showing (if available), then press the OK button to select it.
4. Press OK to confirm your purchase.

Note: To order PPV, the DIRECTV Receiver must be continuously connected to a land-based phone line.

Guide Menu

Guide Menu

The bottom of the Guide screen (refer to page 22) contains three buttons that can be accessed by pressing the GUIDE button on the remote control when the Guide is already displayed.

- Use the ◀▶ buttons to highlight a button and press OK to view its list of options.
- To close the list of options and select another Guide Menu button, press BACK.
- To return to the Guide press BACK again or GUIDE.
- To exit to watch TV, press Exit.

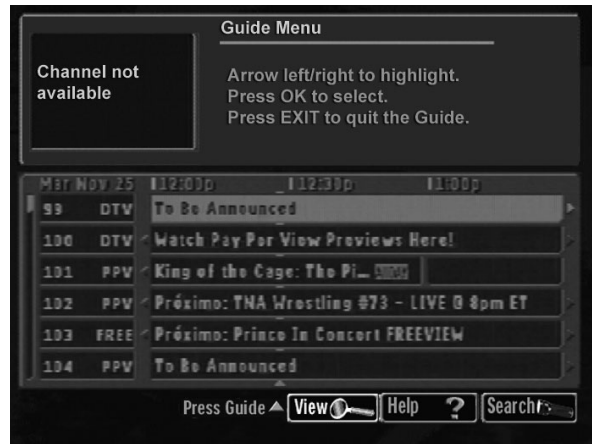

Access the Guide Menu by pressing the GUIDE button while in the Guide

Guide Menu:View

Selecting “View” displays “Go To Time, Pay Per View, Reminder List and Time Reminder.” Use the ▲▼ buttons to select from the View options. Press OK or ▶ to select an option.

- Jump to specific time slot in guide
- EZ Search Pay Per View (see page 20)
- List of Reminders set (see page 23)
- Set a Reminder by specific date, time and duration

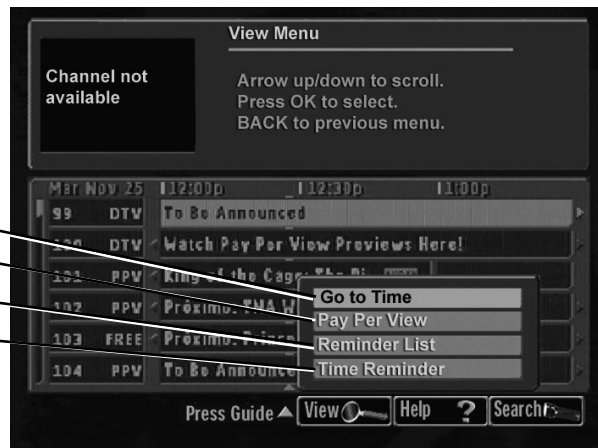

“View” menu options

Guide Menu: Search

Selecting “Search” allows you to search programs based on Category, Title, Actor and Director. Use the ▲▼ buttons to select from the Search options, and press OK or ▶ to select a search option.

- Category
- Title, Actor, Director

Guide Menu: Help

Displays help information on screen. Use the ▲▼ arrows to select a topic and press OK. Press the PAGE+/- to scroll through help information.

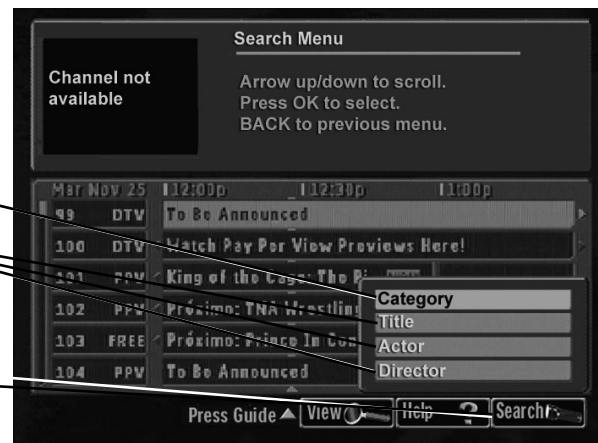

“Search” menu options. “Help” menu available by selecting “Help” and pressing OK

Guide Menu (cont'd)

Guide Menu: Search: Category

A category search allows you to choose from a predefined list of categories and subcategories. The ► arrow indicates the category has subcategories.

1. Use the ▲▼ buttons to highlight a category or the ► arrow to view a list of subcategories.
2. Press OK to select one category or subcategory to search.

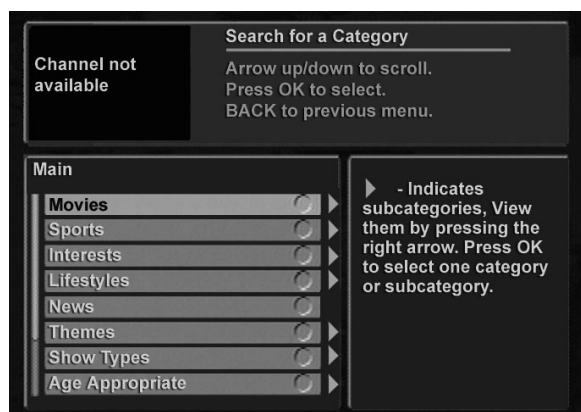

Choose a category to search

Guide Menu: Search: Title/Actor/Director

To search for a specific title, actor or director:

1. Use the ◀▶▲▼ buttons to scroll through the alphabet. Highlight the letter you want, and press OK. Repeat until you have spelled part or all of the title, actor or director's name.
2. When finished, highlight "Done" on the on-screen keyboard and press OK.

Note: Ignore punctuation and accents. For example, enter JOHN'S as JOHNS and DAY-TO-DAY as DAYTODAY. When entering a full name, enter FIRST <space> LAST.



Enter the name of the title, actor or director with the on-screen keyboard

Guide Menu: Search Results

Once your search is completed you will see a list of results on the screen. Use the ▲▼ buttons to highlight a program and press INFO to view the program details or OK to view a list of program showing times.

In addition to the icons on page 19, the list of program showing times includes additional icons to reflect the available alternate audio tracks.

ENG	English	ITA	Italian
ESP	Spanish	JPN	Japanese
FRA	French	KOR	Korean
DEU	German	CHN	Chinese

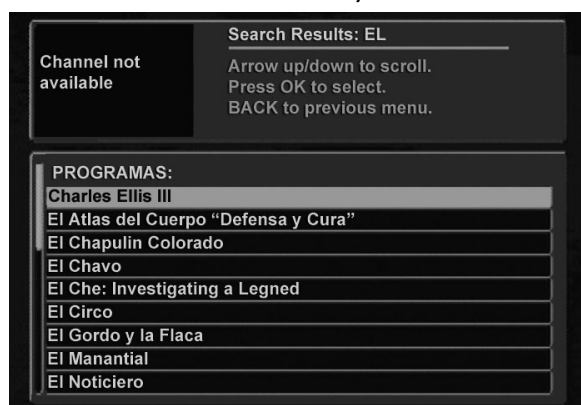

"Search Results" screen

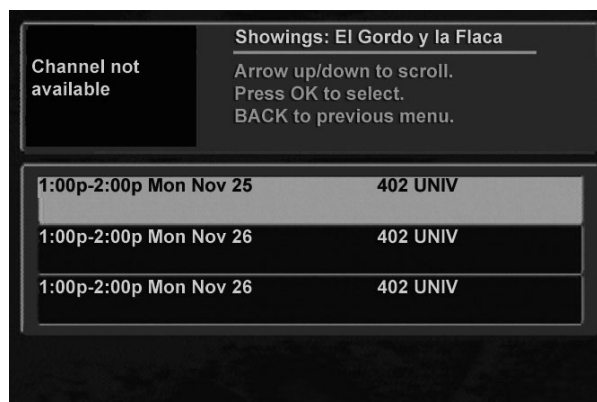

"Showings" screen

Main Menu

Using the Main Menu

The Main Menu lets you customize the features of your DIRECTV® Multi-Room Receiver.

To access the Main Menu from the Guide or TV:

Press the MENU button on the remote control.

To exit the menu:

Press the MENU button or EXIT.

To navigate through the menus:

Use the ▲▼ buttons to highlight an option. Then press OK or ► to confirm the selection and display a sub-menu. Selecting items in a sub-menu displays options in which you can change or review settings.

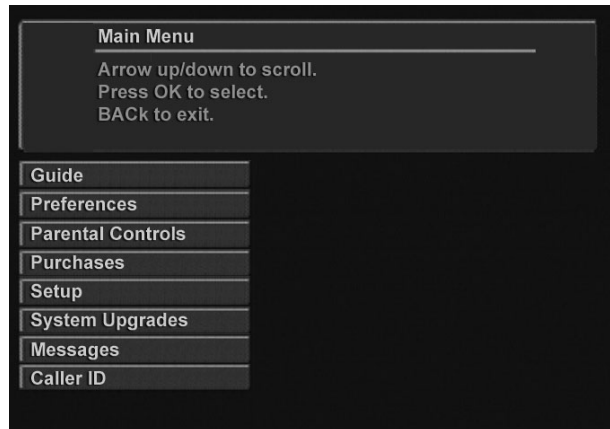

Press MENU button to view Main Menu

Main Menu (cont'd)

Main Menu: Preferences

The Preferences option in the Main Menu lets you change the “Preferred Language”, screen format, or banner duration, set or edit the favorite channels list, set the OSD translucency and access the Channel Output TV2 menu. To change your preferences, select “Preferences” in the Main Menu and press OK. In the sub-menus that display, use the ▲▼ buttons to highlight your selection. Press BACK to return to the Main Menu.

Preferences: Preferred Language

Many programs are broadcast with program information and audio tracks in various languages. You can choose the preferred language for the text displayed on both TVs in Menu and Guide and the audio tracks of programs for each TV respectively in Audio Track.

Notes: Not all programs offer multiple languages. If the selected program is not available in the language you prefer, it defaults to English.

To choose a language:

1. Press MENU. The Guide option will be highlighted. Press ▼ to select “Preferences” and press OK.
2. Select “Preferred Language” and press OK.
3. Use the ▲▼ buttons to choose either “Menu & Guide” or “Audio Track” and press OK. The currently selected language has a checkmark to its right.
4. Use the ▲▼ buttons to choose a language from the list. Press OK.

If desired, repeat steps 3-4 to change the other option.

Note: To change the language of the “Menu & Guide” menu, the DIRECTV® Multi-Room Receiver needs resetting. If you confirm the change as prompted, a viewing interruption will occur as notified on screen.

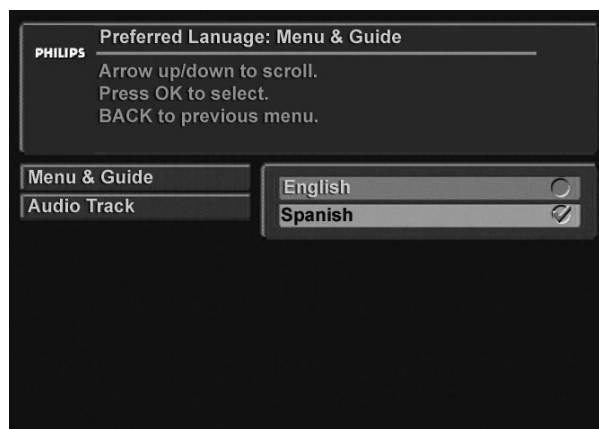

Select preferred language of text in the Menus and Guide in the “Menu & Guide” menu



Select preferred language of every program in the “Audio Track” menu

Preferences: Screen Format

To select a screen format:

1. Press MENU.
2. Press ▼ to select “Preferences” and press OK.
3. Press ▼ to select the “Screen Format” and press OK.
4. Use the ▲▼ buttons to choose from the options.
5. Once you have made your selection, press OK.

Note: Most standard TVs are 4:3 and that is the recommended setting. If you have a widescreen TV, select 16:9.

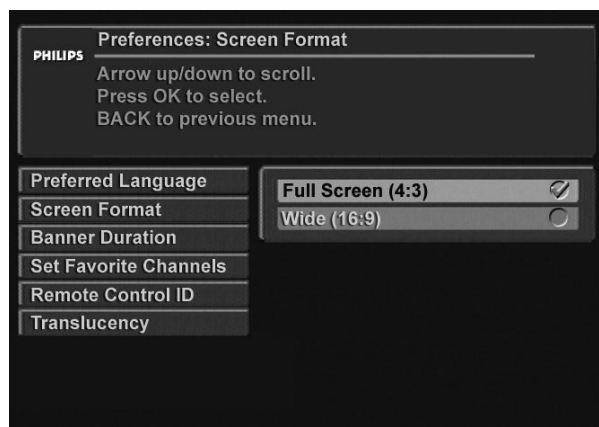

“Screen Format” menu

Main Menu (cont'd)

Preferences: Banner Duration

Banner durations define how long the banner remains on the screen after you press INFO. Options are 5, 10, 15, or 20 seconds. The default value is 10 seconds.

To select the banner duration:

1. Press MENU.
2. Press ▼ to select “Preferences” and press OK.
3. Press ▼ to select “Banner Duration” and press OK.
4. Use the ▲▼ buttons to choose from the options.
5. Once you have made your selection, press OK.

Preferences: Set Favorite Channels

Refer to Enhanced User Features section, page 21.

Preferences: translucency

You can adjust the background translucency to make it easier for you to read the text displayed on the screen.

To set the background translucency:

1. Press MENU.
2. Press ▼ to select “Preferences” and press OK.
3. Press ▼ to select “Translucency” and press OK.
4. Select one of the four translucency levels and press OK.

Preferences: Remote Control ID

You can control the DIRECTV® Multi-Room Receiver and the TV2 remote control attachment independently by assigning a separate ID number to each remote control.

To change the ID number of the remote control:

1. Press MENU.
2. Press ▼ to select “Preferences” and press OK.
3. Press ▼ to select “Remote Control ID” and press OK.
4. The only option available is the alternate ID. Select and press OK.
5. Press and hold down the SAT and MUTE buttons on the remote until the SAT light stays on.
6. To set the ID number to 1, enter “111” or to set the ID to 0, enter “000”. The SAT button will blink twice to confirm the entry.
7. Point the remote at the Receiver and press OK to complete the process.

Note: It is important at the end of the procedure to point the remote at the DIRECTV Receiver and press OK. Otherwise, the remote control will change its ID but the Receiver will not and communication will be lost between the two.



“Banner Duration” menu options

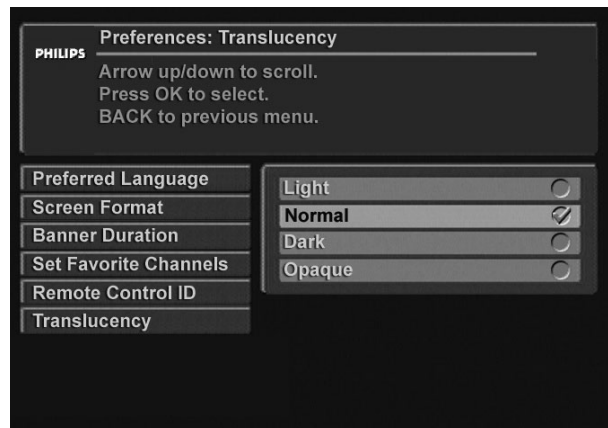

“Translucency” menu options

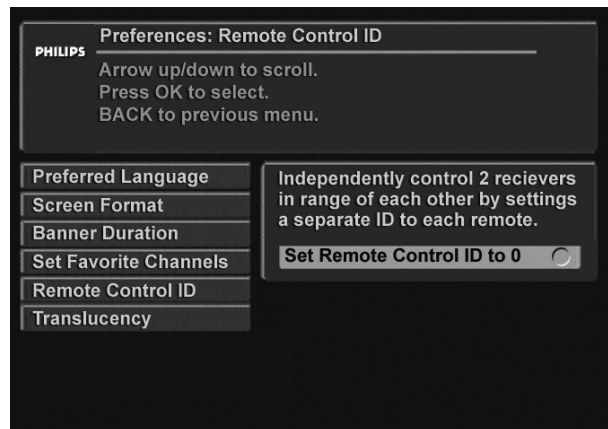

“Remote Control ID” screen

Main Menu (cont'd)

Main Menu: Parental Controls

If you want to control what channels and programs are being watched or how much is being spent on each pay per view purchase, Parental Controls allows you to do this with channel locks, spending limits, and rating limits. Parental Controls are protected by a 4-digit numeric password that you set.

To access this feature:

1. Press MENU.
2. Press ▼ to select "Parental Controls" and press OK.
3. Use the ▲▼ buttons to choose from the options and press OK.

Parental Controls: Lock The System (Lock/Unlock the DIRECTV® Multi-Room Receiver)

Once any Parental Control setting has been configured, the DIRECTV Receiver must be locked in order for those changes to take effect. Your DIRECTV Receiver can be locked or unlocked. When it is locked, the system will prompt you to enter the password whenever you want to change settings in the following menus: "Channel Locks", "Set Rating Limits", or "Set Spending Limits". TV1 and TV2 share this setting. The lock icon in the banner indicates a locked system.

To lock or unlock the system:

1. Choose "Lock The System" (if the system is not locked) or "Unlock The System" (if the system is locked) from the "Parental Controls" menu.
2. When the system prompts you for a password, enter it using the numeric buttons on the remote control. If locking the system, you will need to confirm it before it takes effect. If you have forgotten or lost your password, contact your service provider.

Parental Controls: Channel Locks

 Locking channels prevents a viewer from accessing these channels by requiring a password. Additionally, the system prompts the viewer to choose to lock TV1 or both TVs. You must lock the DIRECTV Receiver to enforce the locks (see above).

To set Channel Locks:

1. Choose "Channel Locks" from the "Parental Controls" menu and press OK.
2. To lock /unlock all channels, use the ▲▼ buttons to select "Lock All", or "Unlock All" and press OK.
3. To manually lock/unlock individual channels, press ►. Then, use the ▲▼ buttons to select a channel and press OK to toggle between lock and unlock.
4. Use the PAGE +/- buttons to scroll the channel list by a full page.
5. To store your new settings, select "Save Changes" using the ▲▼ buttons and press OK.

Parental Controls: Lock Status

The Lock Status feature is used to view the system status, i.e. Locked or Temporarily Unlocked.

To view the receiver Lock Status:

1. Choose "Lock Status" from the "Parental Controls" menu and press OK. Status of both TV1 and TV2 are displayed.



"Parental Controls" menu



"Channel Locks" menu

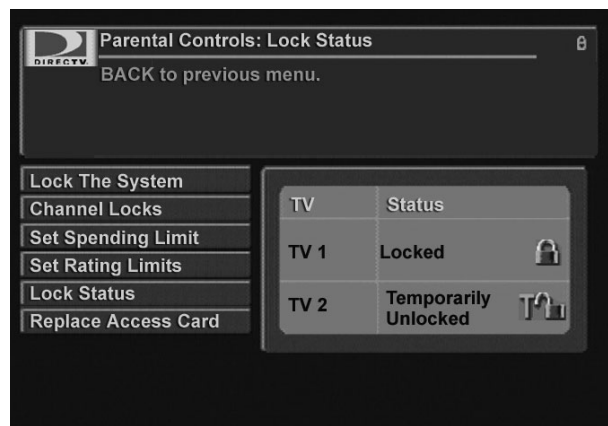

"Lock Status" menu

Main Menu (cont'd)

Parental Controls: Set Spending Limit

You can set a per purchase spending limit on pay per view programs. It is not a cumulative limit. You must lock the DIRECTV® Multi-Room Receiver to enforce this setting (refer to page 29).

To set the Spending Limit:

1. Choose "Set Spending Limit" from the "Parental Controls" menu and press OK. The current purchase limit displays.
2. Enter the spending limit using the numeric buttons on the remote. Or, use the ◀▶ buttons to move from one digit to another; then use the ▲▼ buttons to set the value for each digit.

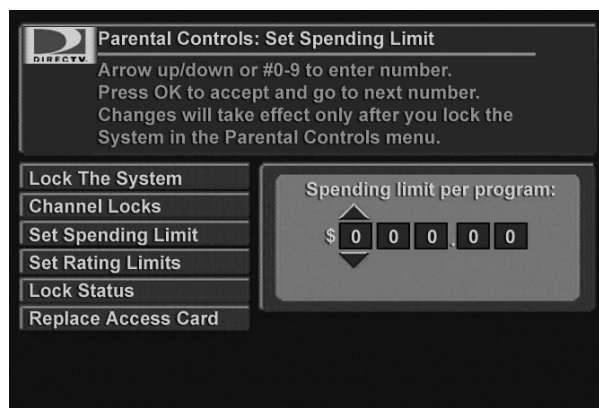

"Set Spending Limit" menu

Parental Controls: Set Rating Limit

You can restrict viewing by setting the rating limits to certain levels. Ratings help you determine programming content, similar to the way films are rated. For example, a rating of "G" is a program suitable for general audiences, while a rating of "R" might be suitable for adults only. You must lock the system to enforce these settings. To view a locked program, you must first enter a password.

To set the Rating Limits:

1. Choose "Set Rating Limits" from "Parental Controls" menu and press OK.
2. There are three rating systems to set: Children-TV, Entire Audience-TV, and MPAA-Movies. You can lock or unlock all ratings in each system. When you lock a particular rating, all ratings exceeding the locked rating are automatically locked as well. For example, if you lock "R", "NC-17" and "X" will be automatically locked. Press ▲▼ to select the desired limit and press OK to lock or unlock it. The Children-TV and Entire Audience-TV options contain sublevel ratings that can further identify the programming content.

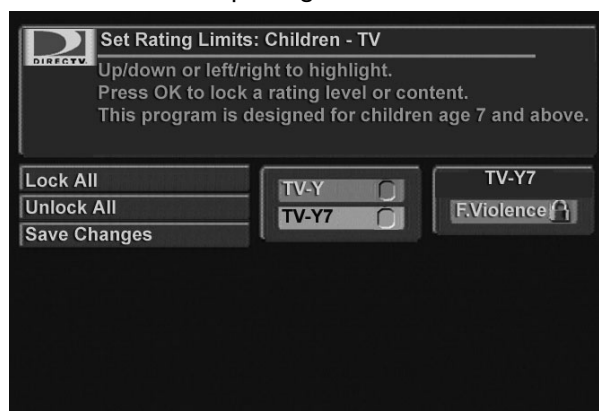

"Children-TV" rating system

Parental Controls: Replace Access Card

Use this menu to replace your current card with a new one, sent by your service provider. Be sure to follow the on-screen instructions. For information on inserting access cards, see page 8.

Note: This menu is available only on TV1.

To replace your access card:

1. Press MENU.
2. Use the ▲▼ buttons on the remote control to highlight "Parental Controls". Press OK.
3. Choose "Replace Access Card", then press OK. Be sure the current access card is inserted in the DIRECTV Multi-Room Receiver. "Copying OLD access card information" will appear on the screen.
4. When prompted, remove the old card, insert the new card, then press OK.
5. When this process is completed, press OK to return to the previous menu.
6. Discard the old card since it no longer works.

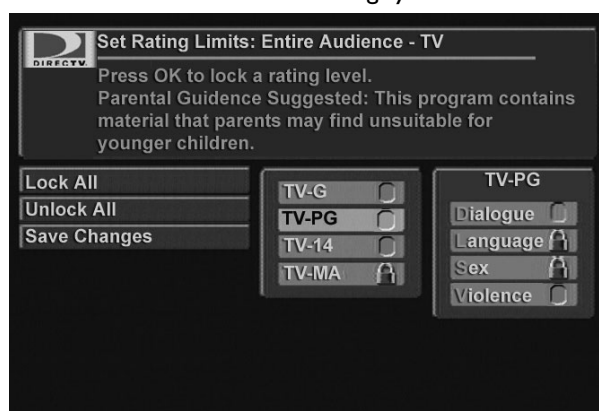

"Entire Audience" rating system

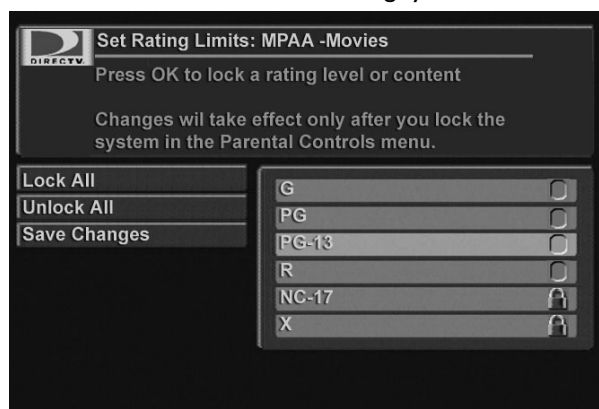

"MPAA-Movies" rating system

Main Menu (cont'd)

Main Menu: Purchases

Purchases: Past Purchases

The Past Purchases menu displays a summary of your past pay per view purchases. It includes the program name and channel number, program date, start and end time, price, and whether the program was viewed or cancelled. Information for all past purchases is stored on the access card and displayed with the most recent purchase first.

To view past purchases:

1. Press MENU.
2. Choose "Purchases" from the main menu and press OK.
3. Use the ▲▼ buttons to choose "Past Purchases" and press OK.
4. A list of past purchases displays indicating whether they were viewed or cancelled. You can scroll through the list using the ▲▼ buttons or using the PAGE+/- buttons to scroll by a full page.

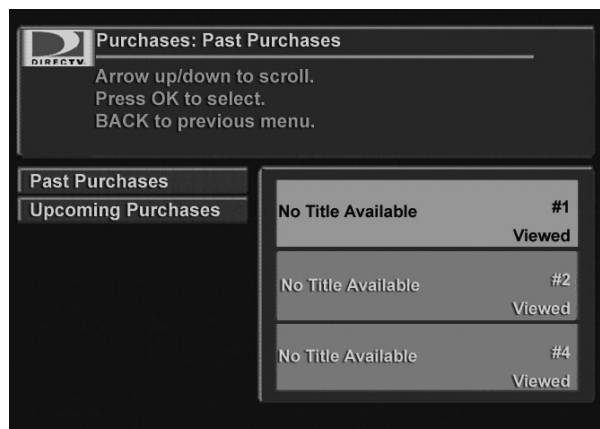

"Past Purchases" menu

Purchases: Upcoming Purchases

The Upcoming Purchases menu displays all future pay per view programs that you have purchased but not cancelled. You may cancel any pay per view program you have not yet watched that was purchased through the DIRECTV® Multi-Room Receiver from either TV.

Note: You cannot cancel a PPV purchase if you have already tuned to the program.

To cancel purchases:

1. Press MENU.
2. Choose "Purchases" from the main menu and press OK.
3. Choose "Upcoming Purchases" and press OK.
4. A list displays of upcoming purchases that were ordered but not viewed. You can scroll through the list using the ▲▼ buttons or using the PAGE+/- buttons to scroll by a full page.
5. To delete a pending purchase, highlight it and press OK. A checkmark will appear.
6. Select "Save Changes" and press OK to cancel all checked programs from the upcoming purchases list.
7. You can verify the purchase was cancelled by checking in the "Past Purchases" menu.

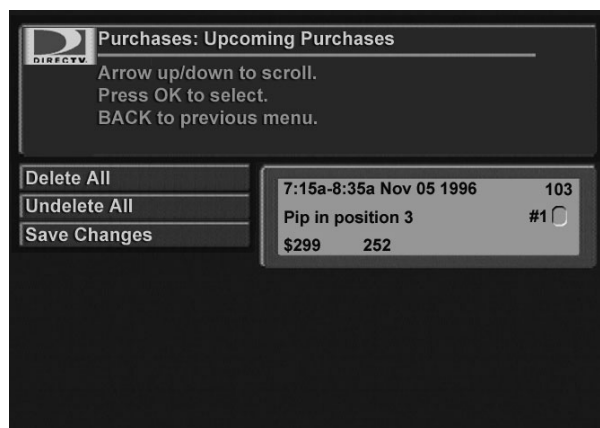

"Upcoming Purchases" menu

Main Menu (cont'd)

Main Menu: Setup

Use this menu to run through the setup process (professional installation is highly recommended). Configure each setting within “Enter ZIP Code” and “Dish Configuration.” Use “Point Dish” and “System Test” to confirm your setup.

To view Setup options:

1. Press MENU.
2. Select “Setup” and press OK.
3. Use the ▲▼ buttons to select one of the “Setup” menu options.

Setup: Enter ZIP Code

Use this function to correctly position the satellite antenna.

To enter your ZIP code:

1. At the “Setup” menu, select “Enter ZIP Code” and press OK.
2. Enter the ZIP code using the numeric buttons on the remote, or use the ▲▼ buttons to select each digit in the ZIP code field. Press the ► button to move to the next field.

Helpful Hint

- Your ZIP code is critical to the installation process.

Setup: Dish Type

Use this function to identify your type of satellite antenna dish.

To select your dish type:

1. At the “Setup” menu, select “Dish Type” and press OK.
2. Use the ▲▼ buttons to select “Manual Selection” if you know the type of dish you have. Otherwise, contact your installer or select “Auto Selection” and press OK.
3. Use the ▲▼ buttons to manually select your dish type and press OK.

Setup: Point Dish

This function is accessible from TV1 or TV2. It is used to manually point the dish and correctly align it with the satellite(s). You may want to have a helper to read the on-screen displays for you during this procedure. Signal strength readings change approximately 2 seconds after each adjustment is made.

Note: Single-dish installations often show higher signal strength than those receiving from two or three satellites. The onscreen display will help you to align your dish based on your ZIP code.

To point your dish:

1. At the Setup menu, select “Point Dish” and press OK.
2. A signal strength meter displays. Adjust the dish until the meter stabilizes at a reading of at least 60. The range is 0 to 100. Audible tones will help you. The tones get faster as the signal strength increases until becoming continuous. If you have problems, refer to the troubleshooting section of this manual (page 35).

Note: The audible tone corresponds to the signal strength of the TV where the action is performed.

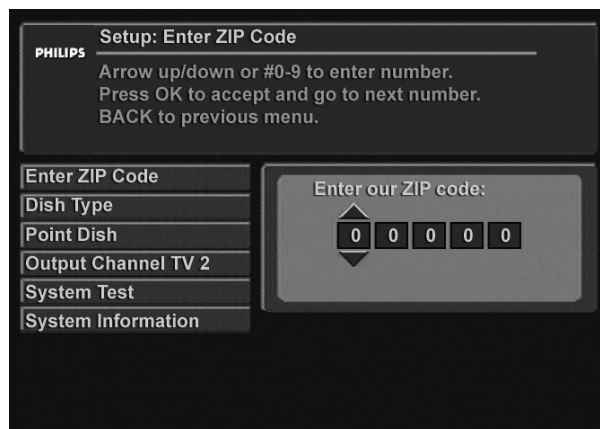

“Enter ZIP Code” menu

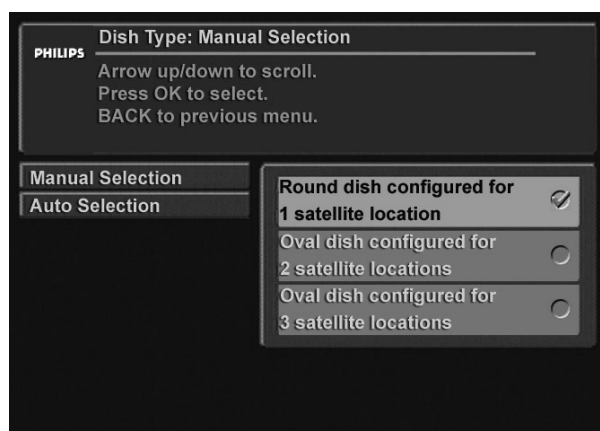

“Manual Selection” menu options

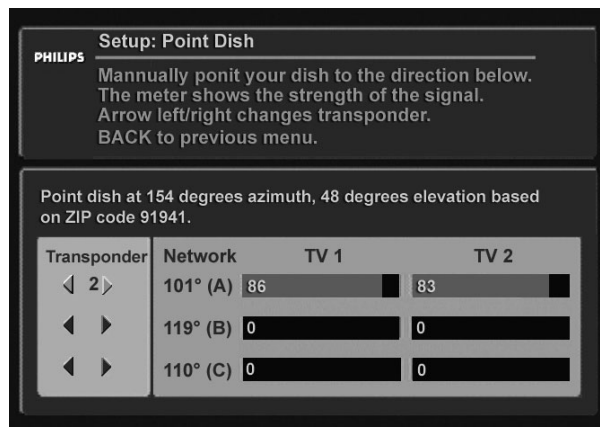

Note: Use the ▲ or ▼ buttons to switch between satellites. Use the ◀ or ▶ buttons to switch between transponders for the selected satellite.

Main Menu (cont'd)

Setup: Output Channel TV2

This menu is used to set the output signal sent to TV2.

1. Press MENU.
2. Press ▼ to select “Setup” and press OK.
3. Press ▼ to select “Output Channel TV2” and press OK.

To enable remote control attachment to TV2:

4. Select “TV2 Remote Attachment” and press OK.
5. Use the ▲▼ buttons to choose “Enable Remote Attachment” or “Disable Remote Attachment” and press OK to confirm and exit the screen.

Note: Enabling remote control attachment will send voltage to your TV2 remote control attachment. If there is no remote control attachment, serious damage may occur to your TV set.

To set the TV2 modulator frequency type:

4. Select “Frequency Type” and press OK.
5. Use the ▲▼ buttons to choose between Terrestrial off-air reception or Cable (CATV) reception. Press OK to confirm and exit the screen.

To set the TV2 modulator frequency:

6. Select “Modulator Frequency” and press OK.
7. Use the ▲▼ buttons to choose a frequency and press OK to confirm and exit the screen.

Note: The modulator frequency should not be modified from TV2. It is preferable to modify it from TV1.

To save the changes:

8. Use the “Save changes” button to access the “Change Confirmation” screen and press “Confirm” in order for the settings to take effect or “Cancel” to cancel the changes.

Note: If you lose video on TV2, check the “Modulator Frequency” screen on TV1 to make sure your modulator frequency and modulator frequency type match your TV2 setup.

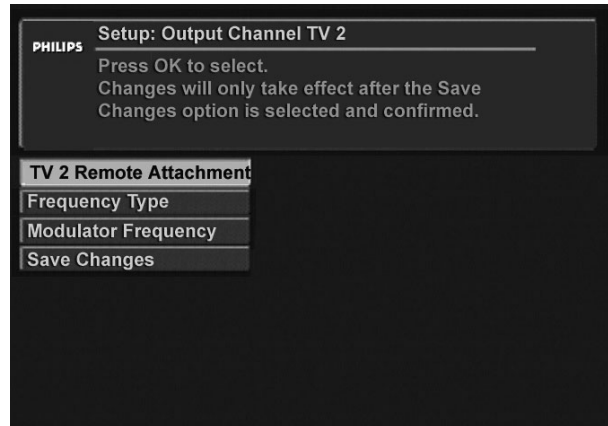

“Output Channel TV2” menu

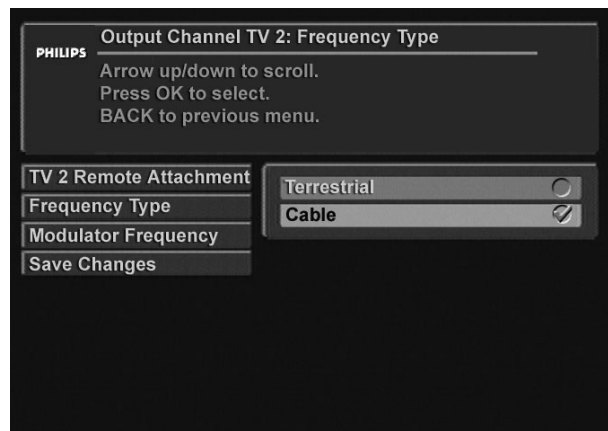

“Frequency Type” menu option

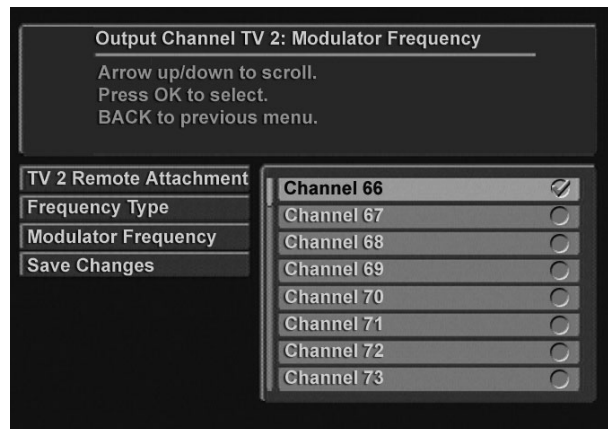

“Modulator Frequency” menu options

Main Menu (cont'd)

Setup: System Test

This option performs a test of the system. This information is useful in troubleshooting if you need to contact customer service.

To run a system test:

1. At the Setup menu, select "System Test" and press OK.
2. To launch a test, press the Run button. A message "Test in progress, Please Wait . . ." may appear. After a few seconds, the test results will display. Press Cancel to cancel a test while in progress.

Note: TV2 displays no test results for the Access Card Status and Phone Line Connection.

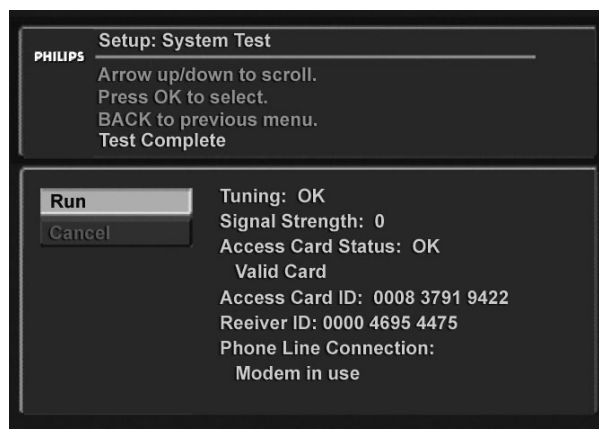

"System Test" menu

Setup: System Information

This option shows information about your hardware and software that will be useful in troubleshooting if you need to contact customer service.

To view system information:

1. At the Setup menu, select "System Information" and press OK.
2. Use the PAGE +/- buttons to scroll the information.



"System Information" menu

Main Menu: System Upgrades

Your DIRECTV® Multi-Room Receiver is able to receive upgrades or modifications to some of its features and functions. These modifications will occur automatically, usually at times when the DIRECTV Receiver is not likely to be in use. If your DIRECTV Receiver is on when an upgrade or modification is sent, reception may be interrupted for a minute or two. Reception should return to normal after the modification is complete. Your DIRECTV Receiver must be plugged in to receive an upgrade. Do not unplug your DIRECTV Receiver while an upgrade is in progress. Consult the System Upgrades menu to find a schedule of upgrades or modifications planned by DIRECTV.

To view past or future upgrades:

1. Press MENU.
2. Select "System Upgrades" in the Main Menu and press OK.
3. Use the ▲▼ buttons to select "Past Upgrades" or "Future Upgrades" and press OK.

Main Menu (cont'd)

Main Menu: Messages



When you receive a new message, the New Incoming Messages icon appears in the banner. You can view and delete messages from either TV. Each message includes the date and time it was sent. When new messages are received, the oldest message is automatically deleted if the maximum amount of messages (30) is exceeded. The banner on the Message screen indicates how many messages you have.

To view messages:

1. Press MENU.
2. Use the ▲▼ buttons to choose “Messages” and press OK.
3. Use the ▲▼ buttons to select and view a message.
4. When a message is displayed, press OK to delete a message (the torn envelope icon indicates a deleted message).
5. When you press BACK or EXIT, all deleted messages are removed permanently and will not display the next time you view messages.

Note: Once a message is read from either TV, it will be displayed as read on both TVs.

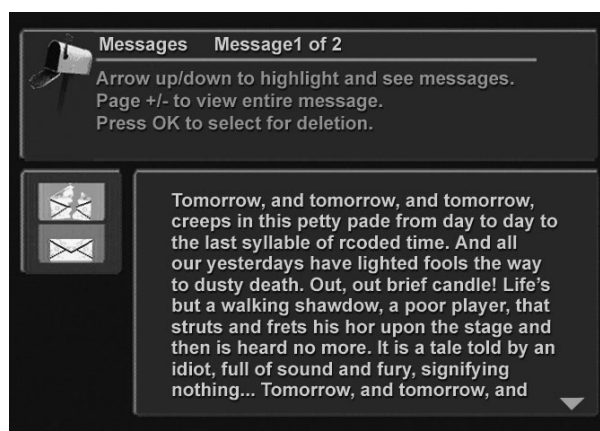

“Messages” menu

Main Menu: Caller ID

This option is used to display caller information when a phone call comes in. It can only be set up from TV1.

To enable or disable Caller ID:

1. Press the MENU button.
2. Use the ▲▼ buttons to select “Caller ID” and press OK. The Caller ID menu appears.

The following message is displayed:

“You must have a phone line connected to your receiver and be subscribed to Caller ID service from your phone service provider.”

3. Use the ▲▼ buttons to select “Enable/Disable” and press OK. The “Caller ID: Enable/Disable” menu appears.
4. Use the ▲▼ buttons to choose to display the Caller number either on TV1 or TV2, or both TV1 and TV2, or none.
5. Press OK to select the highlighted option and close the selection box.

To view Caller ID history:

At the Caller ID screen, use the ▲▼ buttons to select “Call History” and press OK. The history information will be displayed.

Note: Setup and viewing of call history are only accessible from TV1. Caller ID display is available on both TVs.

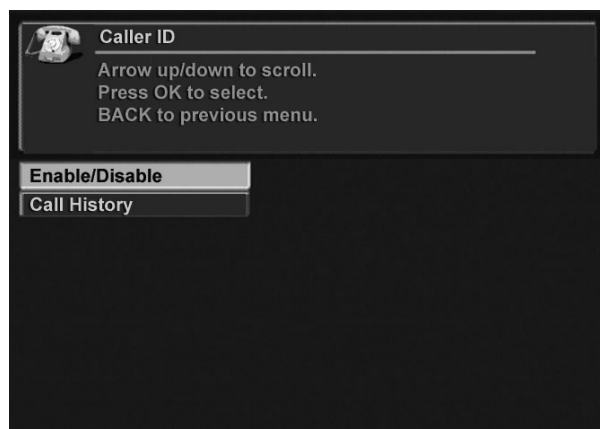

“Caller ID” “Caller ID” options

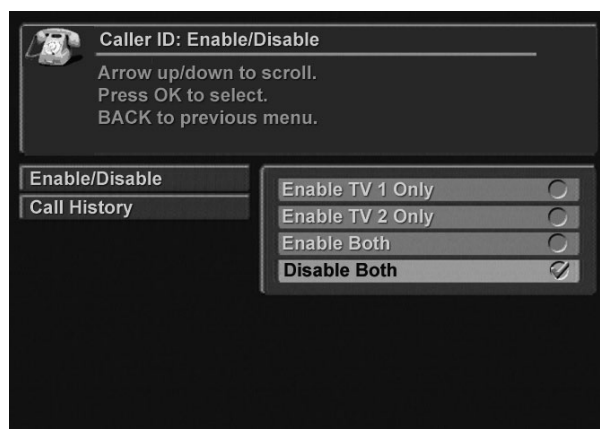

“Caller ID” options

Troubleshooting

Where To Find Help

General help is available by highlighting the "HELP" button in the Guide menu and pressing OK.

Receiver not working properly	Press the Reset button.
No picture / poor picture	<ol style="list-style-type: none"> 1. Press the POWER button on the front panel of the DIRECTV® Multi-Room Receiver if the power indicator LED is not on. 2. Make sure TV power is on. 3. Check TV connection from the DIRECTV Receiver. <ol style="list-style-type: none"> a. If using RF output, tune TV to channel 3 or 4 to match the channel switch on the rear panel of the DIRECTV Receiver. b. If using composite, S-Video, or component outputs, select the proper input on your TV. 4. Make sure the SAT IN coaxial cable is properly connected to the antenna's LNB or multi-switch. Check the cable for kinks. 5. Check the satellite antenna's signal strength (see page 33). To ensure a quality picture, make sure the output signal is coming directly from the DIRECTV Receiver and not through your VCR. 6. Turn DIRECTV Receiver off, unplug, wait 10 to 15 seconds, and plug back in. <p>Note: Adverse weather conditions may affect picture quality.</p>
No sound	<ol style="list-style-type: none"> 1. Make sure that the TV volume is not set to mute. 2. Check audio connections from the DIRECTV Receiver to TV, ensuring you select the proper inputs on your TV. 3. Check if the problem exists on other channels. If so, turn DIRECTV Receiver off, unplug, wait 10 to 15 seconds, and plug back in.
Remote does not work	<ol style="list-style-type: none"> 1. Make sure the batteries are inserted correctly (see page 13) and are not dead. 2. Be sure you are within operating range of the DIRECTV Receiver. 3. Make sure no objects obstruct the line of sight between the remote and the DIRECTV Receiver. 4. Press the SAT button on the remote. 5. If remote control ID was changed so the DIRECTV Receiver and the remote no longer communicate, change the ID number back to the previous ID number (see page 28).
Ordering or cancelling pay per view	<ol style="list-style-type: none"> 1. Cannot order - <ol style="list-style-type: none"> a. It may be too late to purchase the program. Check for other show times. b. Check phone cord connection on rear panel of the DIRECTV Receiver and at the wall jack. Keep phone cord connected. 2. Cannot cancel - you cannot cancel pay per view orders that you've watched or tuned to, or ones not ordered through your DIRECTV Receiver.
Parental Controls	<ul style="list-style-type: none"> • The system must be locked before your Parental Controls settings will take effect (see page 30). • The system must be unlocked before you can make changes to the Parental Controls settings.
Favorites / SmartSurf	Cannot disable – press the POWER button to go into standby and press the POWER again to bring DIRECTV Receiver out of standby.
Audio track incorrect	<ol style="list-style-type: none"> 1. Check the default language settings (see page 27). 2. The program provider may not provide audio in all the languages listed in the “Preferred Language” menu.
Cannot access channel(s)	<ol style="list-style-type: none"> 1. Check that you are subscribing to the station to which you want to tune to. 2. Be sure the system is not locked as indicated by a lock icon in the banner. 3. Make sure SmartSurf and/or Favorites is not turned on. See “Favorites/SmartSurf” above for instructions to cancel either feature.
Caller ID not working	<ol style="list-style-type: none"> 1. Phone line must be directly connected to the phone wall jack. 2. Make sure there are no other devices in the phone connection, such as caller ID boxes.

Troubleshooting TV2

This section is specific to TV2.

No picture	<ol style="list-style-type: none">1. Make sure TV2 power is on. The TV2 power indicator on the front panel of the receiver should be on.2. Check TV2 connections.3. Check the DIRECTV® Multi-Room Receiver output settings:<ol style="list-style-type: none">a. check the selected frequency type (i.e. Terrestrial or Cable) is correct (see page29).b. check the modulator frequency is set on the appropriate channel (see page29).
No sound	<ol style="list-style-type: none">1. Make sure that the TV2 volume is not set to mute.2. Check TV2 connections.
Remote does not work	<ol style="list-style-type: none">1. Make sure the batteries are inserted correctly (see page 13) and are not dead.2. Be sure you are within operating range of the TV2 remote control attachment.3. Make sure no objects obstruct the line of sight between the remote and the TV2 remote control attachment.4. The TV2 remote control attachment LED is off:<ol style="list-style-type: none">a. check the TV2 remote control attachment connections.b. check TV2 remote control attachment is enabled.5. The TV2 remote control attachment LED is on:<ol style="list-style-type: none">a. check you are using the TV2 remote control.b. if the remote control ID was changed so the DIRECTV Receiver and the remote no longer communicate, change the ID number back to the previous ID number (see page 28).

Limited Warranty

Digital Satellite Receiver

90 Days Free Exchange / 91 Days-One Year Nominal Fee Exchange
This product must be carried in for repair.

WHO IS COVERED?

You must have proof of purchase to receive warranty service. A sales receipt or other document showing that you purchased the product is considered proof of purchase.

WHAT IS COVERED?

Warranty coverage begins the day you buy your product. For 90 days from the date of purchase, the Digital Satellite Receiver will be replaced with a new, repaired, renewed, or comparable product (whichever is deemed necessary) if it becomes defective or inoperative. This exchange is done at no charge to you.

From 91 days to one year from the date of purchase, you must pay a nominal fee for a new or renewed product. This exchange offer ends one year after the date of purchase.

All products, including replacement products, are covered only for the original warranty period. When the warranty on the original product expires, the warranty on the replacement product also expires.

WHAT IS EXCLUDED?

Your warranty does not cover:

- labor charges for installation or setup of the product.
- installation, performance of, or repair of audio/video cabling, telephone line, or accessory attachments used in accessory ports outside of the product.
- product replacement because of misuse, accident, lightning damage, unauthorized repair, or other cause not within the control of DIRECTV.
- incidental or consequential damages resulting from the product. (Some states do not allow the exclusion of incidental or consequential damages, so the above exclusion may not apply to you.)
- reception transmission problems caused by signal conditions, telephone line, or cable or antenna systems outside the unit.
- a product that requires modification or adaptation to enable it to operate in any country other than the country for which it was designed, manufactured, approved and/or authorized, or repair of products damaged by these modifications.
- a product used for commercial or institutional purposes.
- DIRECTV service is separate and distinct from this product (hardware) warranty.

WHERE IS EXCHANGE AVAILABLE?

You may exchange the product in all countries where the product is officially distributed by Philips. In countries where Philips does not distribute the product, the local Philips service organization will attempt to provide a replacement product (although there may be a delay if the appropriate product is not readily available).

MAKE SURE YOU KEEP...

Please keep your sales receipt or other document showing proof of purchase. Attach it to this owner's manual and keep both nearby. Also keep the original box and packing material in case you need to return your product.

BEFORE REQUESTING EXCHANGE...

Please check your owner's manual before requesting exchange. Adjustments of the controls discussed there may save you a call.

TO EXCHANGE YOUR PRODUCT...

An exchange will be managed by DIRECTV. If you believe you need to exchange your Digital Satellite Receiver, contact DIRECTV at 1-800-531-5000. A representative will go through a diagnostic checklist with you. If it is determined that the product needs to be exchanged, you will receive a return authorization number. The representative will give you complete shipping details.

TO GET OUT-OF-WARRANTY EXCHANGE...

To exchange your product after the warranty expires, contact DIRECTV at 1-800-531-5000 to determine the cost of out-of-warranty exchange for your product.

All implied warranties, including implied warranties of merchantability and fitness for a particular purpose, are limited in duration to the duration of this express warranty. Some states do not allow limitations on how long an implied warranty lasts, so the above limitation may not apply to you.

This warranty gives you specific legal rights. You may have other rights which vary from state/province to state/province.

Philips, P. O. Box 520890, Miami, FL 33152 (402) 536-4171

EL6471E002 / 8-02