

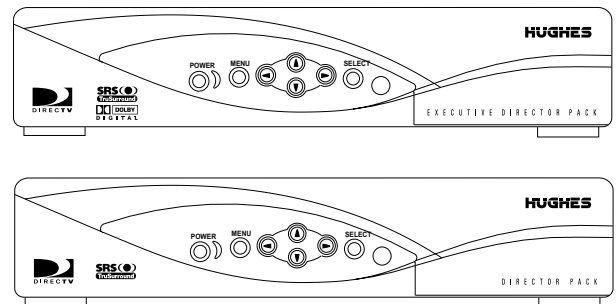

HUGHES

DIRECTV® Receiver

Owner's Manual



*Models HAH-SA
HBH-SA
SD-HBH*

HUGHES WARRANTY REGISTRATION

You may REGISTER ONLINE at: www.hns-usa.com/warranty

or complete the registration form on the back of this manual.

Copyright 2001, 2002, 2003 Hughes Network Systems, Inc., a wholly owned subsidiary of Hughes Electronics Corporation. All rights reserved. This publication and its contents are proprietary to Hughes Network Systems, Inc., a wholly owned subsidiary of Hughes Electronics Corporation. No part of this publication may be reproduced in any form or by any means without the written permission of Hughes Network Systems, Inc., 11717 Exploration Lane, Germantown, Maryland 20876.

Hughes Network Systems, Inc. has made every effort to ensure the correctness and completeness of the material in this document. Hughes Network Systems, Inc. shall not be liable for errors contained herein. The information in this document is subject to change without notice. Hughes Network Systems, Inc. makes no warranty of any kind with regard to this material, including, but not limited to, the implied warranties of merchantability and fitness for a particular purpose. Covered by one or more of the following U.S. Patents: 6,075,526; 5,828,419; 5,751,372; 5,694,176; and 5,635,989. This product is subject to one or more U.S. or foreign patents pending.

Software contained in the HAH-SA, HBH-SA and SD-HBH receivers and referenced in this manual is copyright© 1995-2003 by Hughes Network Systems, Inc., a wholly owned subsidiary of Hughes Electronics Corporation. Some features are patent pending. WatchWizard, PreSelect, TurboTune, and OneLine Guide are trademarks of Hughes Network Systems. "NFL," the NFL Shield, and "NFL SUNDAY TICKET" are registered trademarks of the National Football League and its affiliates. "NHL," the NHL Shield, and "NHL CENTER ICE" are registered trademarks of the National Hockey League. "MLB," "MLB EXTRA INNINGS," "Major League Baseball," and the Major League Baseball silhouetted batter logo are service marks of Major League Baseball Properties, Inc. Major League Baseball trademarks and copyright are used with permission of Major League Baseball Properties, Inc. All other trademarks and service marks are the property of their respective owners.

Disclaimer – Every effort has been made to ensure the correctness and completeness of the material in this document. No company shall be liable for errors contained herein. The information in this document is subject to change without notice, No warranty of any kind is made with regard to this material, including, but not limited to, the implied warranties of merchantability and fitness for a particular purpose.

Trademarks – DIRECTV and the Cyclone Design logo, DIRECTV INTERACTIVE, TOTAL CHOICE and DIRECTV HOME SERVICES are trademarks of DIRECTV, Inc., a unit of Hughes Electronics Corp. FREEVIEW is a registered trademark of Hughes Electronics Corporation. All trademarks, marks, names, or product names referenced in this publication are the property of their respective owners, and Hughes Network Systems neither endorses nor otherwise sponsors any such products or services referred to herein.

Dolby Laboratories Information – Manufactured under license from Dolby Laboratories. "Dolby," "Pro Logic," and the double-D symbol are trademarks of Dolby Laboratories.

Macrovision® Information – Macrovision is a registered trademark of Macrovision Corporation. This device incorporates an anticopy process technology that is protected by U.S. patents 4,631,603; 4,577,216; 4,819,098; and other intellectual property rights. The anticopy process is licensed for noncommercial, home use only. Reverse engineering or disassembly is prohibited.

StarSight® Information – StarSight® features licensed under one or more of the following patents: 4,706,121; 5,151,789; 5,353,121; 5,353,277; 5,479,266; 5,479,268; and 5,532,754. Use rights reserved.

TruSurround™ Information – TruSurround™ and the  symbol are trademarks of SRS Labs, Inc. TruSurround technology is incorporated under license from SRS Labs, Inc.

WINK® Information – WINK® and the  symbol are registered trademarks of WINK Communications, Inc.

ENERGYSTAR® Information – ENERGYSTAR® and the ENERGYSTAR certification mark are registered US marks.

Note on recording programming – Most television programs and films are copyrighted. This means that someone has legal rights governing the reproduction and distribution of this material. In certain circumstances, copyright law may apply to private in-home taping of copyrighted materials. In most cases, it is permissible to record for your personal use, as long as you do not sell the material. You must act responsibly in this area—check into the matter if you are unsure.

Some pay per view programs may be licensed from producers as "view-only" programs. These are copyrighted programs, and may not be copied or reproduced for any purpose without the express written permission of the copyright owner.

DIRECTV® Programming – ACTIVATION OF PROGRAMMING MAY BE SUBJECT TO CREDIT CARD APPROVAL AND REQUIRES VALID SERVICE ADDRESS, SOCIAL SECURITY NUMBER, AND/OR MAJOR CREDIT CARD. Deposit or prepayment may be required. Programming subject to change. You must be physically located in the United States (U.S.) to receive DIRECTV service. DIRECTV services are not available outside the United States. DIRECTV programming is sold separately and independently of DIRECTV System hardware. A valid programming subscription is required to operate DIRECTV System hardware. Activate your DIRECTV programming today at 1-800-DIRECTV (1-800-347-3288).

DIRECTV System hardware and installation – To arrange for professional installation of your DIRECTV System, ask questions, or resolve problems related to your DIRECTV System, contact your dealer. If you need more information, please contact our technical support line at 1-800-274-8995.

Spanish language owner's manual – A Spanish language version of this manual is available upon request. To obtain a copy, contact the Customer Care Center at 1-800-274-8995. You may also download a copy of the manual from www.hns.com on the internet.

Manual del propietario en idioma español – Contamos con una versión de este manual en idioma español, que está a su disposición. Para obtener una copia, llame al Centro de Atención al Cliente al 1-800-274-8995. También puede descargar una copia del manual en Internet en www.hns.com.

Please record the following information for warranty

System Model #: _____ (if applicable)

Receiver Model #: _____

Receiver Serial #: _____

Access Card #: _____

Receiver Serial #: _____

Receiver ID #: _____

Important Safety Instructions

For your safety and protection, read this entire Owner's Manual before you attempt to install or use your satellite system. In particular, read this safety section carefully. Keep this safety information where you can refer to it if necessary.

Heed Cautions—All cautions on the product and in the operating instructions should be adhered to.

Follow Instructions—All operating and use instructions should be followed.

THESE CAUTIONS AND SYMBOLS APPEAR ON THE BACK OF THE RECEIVER

WARNING or CAUTION

Double insulated systems are protected by additional board clearances and creepage, so that the unit will not be a safety hazard to the end-user.

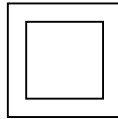

IMPORTANT SAFETY INSTRUCTIONS

1. Read these instructions.
2. Keep these instructions.
3. Heed all warnings.
4. Follow all instructions.
5. Do not use this apparatus near water.
6. Clean only with dry cloth.
7. Do not block any ventilation openings. Install in accordance with the manufacturer's instructions.
8. Do not install near any heat sources such as radiators, heat registers, stoves, or other apparatus (including amplifiers) that produce heat.
9. Do not defeat the safety purpose of the polarized or grounding-type plug. A polarized plug has two blades with one wider than the other. A grounding type plug has two blades and a third grounding prong. The wide blade or the third prong is provided for your safety. If the provided plug does not fit into your outlet, consult an electrician for replacement of the obsolete outlet.
10. Protect the power cord from being walked on or pinched particularly at plugs, convenience receptacles, and the point where they exit from the apparatus.
11. Only use attachments/accessories specified by the manufacturer.
12. Unplug this apparatus during lightning storms or when unused for long periods of time.
13. Refer all servicing to qualified service personnel. Servicing is required when the apparatus has been damaged in any way, such as power-supply cord or plug is damaged, liquid has been spilled or objects have fallen into the apparatus, the apparatus has been exposed to rain or moisture, does not operate normally, or has been dropped.

INSTALLATION

Polarization – This DIRECTV® Receiver is equipped with a plug that will fit into the power outlet only one way. Do not modify the plug defeating this feature. If the plug does not fit, contact your electrician to replace your outlet. To prevent electric shock, do not use this plug with an extension cord or outlet unless you can fully insert the blades without blade exposure

Power Sources – Operate this DIRECTV Receiver only from the type of power source indicated on the marking label. If you are not sure of the type of power supply to your home, consult your dealer or local power company.

Power-Cord Protection – Protect the power cord from being walked on or pinched particularly at plugs, convenience receptacles, and the point where they exit from the apparatus.

Overloading – Do not overload wall outlets, extension cords, or integral convenience receptacles as this can result in a risk of fire or electrical shock.

Ventilation – Slots and openings in the cabinet are provided for ventilation to ensure reliable operation of the product and to protect it from overheating. Do not block any ventilation openings. Install in accordance with the manufacturer's instructions.

The openings should never be blocked by placing the product on a bed, sofa, rug, or similar surface. This product should not be placed in a built-in installation such as a bookcase or rack unless proper ventilation is provided and the manufacturer's instructions have been adhered to.

For electrical safety, power line operated equipment or accessories connected to this unit should bear the UL listing mark and should not be modified so as to defeat the safety features. This will help avoid any potential hazard from electrical shock or fire. If in doubt, contact qualified service personnel.

Heat–Do not install near any heat sources such as radiators, heat registers, stoves, or other apparatus (including amplifiers) that produce heat.

Accessories – To avoid personal injury or damage to the DIRECTV Receiver, do not place the DIRECTV Receiver on any unstable cart, stand, table, or bracket. Any mounting of the product should follow the manufacturer's instructions.

Attachments – Do not use attachments unless recommended by DIRECTV as they may cause hazards.

Satellite Dish Antenna Grounding – The outdoor satellite dish antenna used to receive satellite signals and the cable used to connect the satellite dish antenna to the indoor receiving unit are required to comply with local installation codes and the appropriate sections of the National Electric Code (NEC) and in particular Article 810-15, which covers proper installation and grounding of television receiving equipment, as well as to Article 820-33, which specifies that the satellite dish antenna cable ground shall be connected to the grounding system of the building as close to the point of cable entry as practical. These codes require proper grounding of the metal structure of the outdoor satellite dish antenna and grounding of the connecting cable at a point where it enters the house (or other building). If you are having a professional installer perform the installation, the installer must observe installation codes. This manual contains instructions on how to make the installation in compliance with the NEC. If additional local installation codes apply, contact local inspection authorities.

Example of Antenna Grounding according to the National Electrical Code instructions contained in "Radio and Television Equipment".

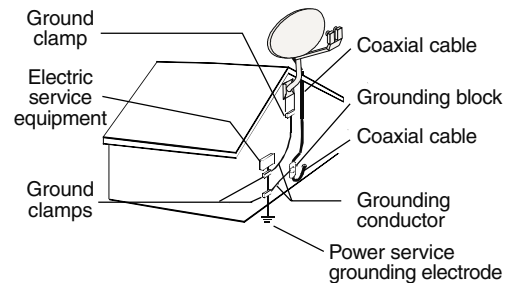

Note: The DIRECTV Receiver must be grounded through the satellite/local antenna cable before plugging into the telephone jack, and it must remain grounded thereafter.

Water and Moisture – WARNING! To reduce the risk of fire or electric shock, do not expose this product to rain or moisture.

Lightning – For added protection for this product during a lightning storm, or when it is left unattended and unused for long periods of time, unplug it from the wall outlet, disconnect the antenna and cable system, and disconnect it from the telephone line. This will prevent damage to the product due to lightning and power-line surges.

Television Antenna Information – Installing an outdoor antenna can be hazardous and should be left to a professional antenna installer. Do not locate the outside antenna system in the vicinity of overhead power lines or other electric light or power circuits, or where it can fall into such power lines or circuits. When installing an outside antenna system, take extreme care to keep from touching such power lines or circuits, as contact with them might be fatal. If an outside antenna is connected to the DIRECTV Receiver, be sure the antenna system is grounded so as to provide some protection against voltage surges and built-up static charges. This DIRECTV Receiver is equipped with a plug that will fit into the power outlet only one way. Do not modify the plug defeating this feature. If the plug does not fit, contact your electrician to replace your outlet. To prevent electric shock, do not use this plug with an extension cord or outlet unless you can fully insert the blades without blade exposure. Section 810 of the NEC, NFPA No. 70 1987, provides information with respect to proper grounding of the mast and supporting structure, grounding of the lead-in wire to an antenna discharge unit, size of the grounding conductors, location of antenna discharge unit, connection to grounding electrodes, and requirements for the grounding electrode.

Power Lines – Extreme care must be taken when installing and adjusting or maintaining the outdoor antenna and connecting cable, especially in the vicinity of overhead power lines, electric lights, or power circuits. When installing the outdoor antenna or cable, extreme care should be taken to keep from touching or approaching such power lines or circuits, as contact with them might be fatal.

Cleaning – Unplug this receiver from the wall outlet before cleaning. Do not use liquid or aerosol cleaners. Use only a damp cloth for cleaning.

Object and Liquid Entry – Never push objects of any kind into this DIRECTV Receiver through openings as they may touch dangerous voltages or "short out" parts that could result in a fire or electric shock. Never spill liquid of any kind on the receiver. No objects filled with liquids, such as vases, shall be placed on the apparatus.

SERVICE

Servicing—Do not attempt to service this DIRECTV® Receiver yourself as opening or removing covers may expose you to dangerous voltage or other hazards. There are no user serviceable parts inside. Refer all servicing to qualified service personnel.

Conditions Requiring Service—Unplug the DIRECTV Receiver from the wall outlet and refer servicing to qualified personnel under the following conditions:

- When the power supply cord or plug has been damaged.
- If liquid has been spilled on, or objects have fallen into, the DIRECTV Receiver or it has been exposed to water.
- If the DIRECTV Receiver does not operate normally by following the operating instructions. Adjust only those controls that are covered by the operating instructions. Other adjustments may result in damage and will often require extensive work by a qualified technician to restore the DIRECTV Receiver to its normal operation.
- If the DIRECTV Receiver has been dropped or the cabinet has been damaged.
- When the DIRECTV Receiver exhibits a distinct change in performance.

Replacement Parts—When replacement parts are required, have the technician verify that the replacements being used have the same safety characteristics as the original parts. Use of replacement parts specified by the manufacturer can prevent fire, electric shock, or other hazards.

Safety Check—Upon completion of any service or repairs to this DIRECTV Receiver, ask the service technician to perform safety checks recommended by the manufacturer to determine that the DIRECTV Receiver is in safe operating condition.

Multi-satellite capability—Multi-satellite capable if used with a DIRECTV Multi-Satellite Dish Antenna, not included.

Automatic upgrades—Your DIRECTV Receiver is able to receive upgrades or modifications to some of its features and functions. These modifications will occur automatically, usually at times when the receiver would likely be turned off. If your receiver is on when an upgrade or modification is sent, you may experience a disruption in reception for a minute or two. Your reception should return to normal after the modification is complete. Your receiver must be plugged in to receive any upgrades. Do not unplug your receiver while an upgrade is in progress. Please consult the Upgrade menu to find a schedule of upgrades or modifications planned by DIRECTV.

Local channel availability—With this receiver (HAH-SA, HBH-SA, SD-HBH) and the proper satellite dish antenna, you may be able to subscribe to local channels from DIRECTV in certain areas. Additional equipment may be required in some markets. Check with your retailer or visit DIRECTV.com for information on availability of local channels from DIRECTV in your area.

Federal Communications Commission (FCC) Regulatory Information

Declaration of Conformity—Standards to which Conformity is declared: FCC Part 15

This device complies with Part 15 of the FCC Rules. Operation is subject to the following two conditions: (1) this device may not cause harmful interference, and (2) this device must accept any interference received, including interference that may cause undesired operation.

- Responsible Party's Name: Hughes Network Systems, Inc.
Address: 11717 Exploration Lane, Germantown, MD 20876
Telephone: 1-800-274-8995
- Trade Name: Hughes
- Type of Equipment: Satellite Receiver
- Model Numbers: HAH-SA, HBH-SA, SD-HBH, HRMC-11, HRMC-12, HRMC-13

Federal Communications Commission (FCC)—This equipment complies with both Part 15 and Part 68 of the FCC rules

Part 15 Compliance—This equipment has been tested and found to comply with the limits for a Class B digital device, pursuant to Part 15 of the FCC rules. These limits are designed to provide reasonable protection against harmful interference in a residential installation. This equipment generates, uses, and can radiate radio frequency energy and, if not installed and used in accordance with the instructions, may cause harmful interference to radio communications.

However there is no guarantee that interference will not occur in a particular installation. If this equipment does cause harmful interference to radio or television reception, which can be determined by removing and applying power to the equipment, the user is encouraged to try to correct the interference by one or more of the following measures:

- Reorient or relocate the receiving satellite dish antenna.
- Increase the separation between the equipment and the DIRECTV® Receiver.
- Connect the equipment into an outlet on a circuit different from that to which the DIRECTV Receiver is connected.
- Consult the dealer or an experienced radio/TV technician for help.

The user may find the following booklet, prepared by the Federal Communications Commission, helpful: "How to Identify and Resolve Radio and TV Interference Problems." This booklet is available from the U.S. Government Printing Office, Washington, DC.

To meet FCC requirement, only peripherals (computer input/output devices, terminals, printers, etc.) certified to comply with Class B limits may be attached to this device. Operation with noncertified peripherals is likely to result in interference to radio and TV reception.

To meet FCC requirements, shielded cables are required to connect the device to a personal computer, peripheral, or other Class B certified device.

Part 68 Compliance—This equipment complies with Part 68 of the FCC rules and requirements adopted by the ACTA. On the rear panel of this equipment is a label that contains, among other information, a product identifier in the format US:5L4DT00B3003670. If requested, this information must be provided to the Telephone Company.

A plug and jack used to connect this equipment to the premises wiring and telephone network must comply with the applicable FCC Part 68 rules and requirements adopted by the ACTA. A compliant telephone cord and modular plug is provided with this product. It is designed to be connected to a compatible modular jack that is also compliant. See installation instructions for details.

The REN is used to determine the number of devices that may be connected to a telephone line. Excessive RENs on the telephone line may result in the devices not ringing in response to an incoming call. In most, but not all areas, the sum of RENs should not exceed five (5.0). To be certain of the number of devices that may be connected to the line, as determined by the total RENs, contact the local Telephone Company. For products approved after July 23, 2001, the REN for this product is part of the product identifier that has the format US:5L4DT00B3003670. The digits represented by the ## are the REN without the decimal point (e.g., 03 is a REN of 0.3). For earlier products, the REN is separately shown on the label.

If the DIRECTV Receiver (Model Numbers: HAH-SA, HBH-SA, SD-HBH) causes harm to the telephone network, the Telephone Company will notify you in advance that temporary discontinuance of service may be required. But if advance notice isn't practical, the Telephone Company will notify the customer as soon as possible. Also, you will be advised of your right to file a complaint with the FCC if you believe it is necessary.

The Telephone Company may make changes in its facilities, equipment, operations, or procedures that could affect the operation of the equipment. If this happens, the Telephone Company will provide advance notice in order for you to make the necessary modifications to maintain uninterrupted service.

If trouble is experienced with the DIRECTV Receiver (Model Numbers: HAH-SA, HBH-SA, SD-HBH) equipment, for repair or warranty information, please contact

Hughes Customer Care Center
Germantown, MD 20876
Telephone Number: 1-800-274-8995
<http://www.hns.com>
email: hughestv@hns.com

If the equipment is causing harm to the telephone network, the Telephone Company may request that you disconnect the equipment until the problem is resolved.

Hughes Network Systems must make any necessary repairs to the modem portion of this equipment in order to maintain valid FCC registration. Do not attempt to repair or service your modem. Return it to Hughes Network Systems.

No repairs can be made by customers. All repairs must be done by Hughes Network Systems Authorized Service Centers (ASCs). This equipment cannot be used on public coin service provided by the Telephone Company. Connection to Party Line Service is subject to state tariffs. Contact the state public utility commission, public service commission or corporate commission for information.

Getting Started	1	Listing unviewed purchases	25
Setup overview	1	Adjusting audio settings	25
Attach the satellite antenna cable	2	Setting default and alternate audio	25
Connect your TV	3	Using TruSurround	26
Determine antenna angles	4	Using Dolby Digital audio	26
Testing your system	5	Adjusting video settings	26
To perform the Transponder test:	5	Using WatchWizard™	27
Using the Channels search	28	Using the Program Director	28
Adding system components	7	Scheduling or editing an event	29
Connecting additional system components	7	Adjusting system settings	30
Connecting a terrestrial antenna/CATV	7	Set output channel.	30
Connecting a VCR	7	Input key enable/disable	30
Connect the VCR Control Cable.	8	Select menu language	30
Test the VCR (Record/Stop)	8	Caller ID enable/disable	30
Connecting a home entertainment system.	9	Restore factory default settings.	30
Using the remote control	11	Viewing Mail	31
Remote control functions	13	Using Caller ID.	31
Programming the remote control.	14	Setting favorites and filters	33
Code Entry.	14	Using favorite channel lists.	33
Code Scanning.	15	Creating a channel list.	33
Changing the Remote ID.	15	Renaming a channel list:	34
Installing remote control batteries.	15	Creating an Auto Set list.	34
Using program guides	17	Adding and removing channels	34
Selecting a program guide style	17	Finding new channels	35
Grid guide	17	Filtering the program guide	35
Logo guide.	18	Using Theme Filters	35
Program guide and menu features	19	Selecting guide times	36
Using the OneLine™ Guide	20	Using access controls	37
Using TurboTune™	20	Locking & unlocking the system	37
Setting TurboTune channels	20	How to lock the system.	37
Renaming TurboTune groups	21	Unlocking the system	37
Using DIRECTV INTERACTIVE™		Setting ratings limits	37
<i>powered by Wink Communications®</i>	21	Setting spending and time limits.	38
Setting guide preferences	22	Questions & Answers	39
Using the menus	23	Manufacturers device control codes	41
Onscreen menu icons	24		
Purchasing pay per view (PPV) events	24		
Cancelling purchases.	24		
Reviewing past purchases	24		

You may connect a second DIRECTV Receiver to the unused LNB output. These instructions also apply to an additional receiver.

This chapter explains how to:

- Connect the DIRECTV® Satellite Dish Antenna to your DIRECTV Receiver (*this page*).
- Connect your DIRECTV Receiver to your TV (*see page 3*).
- Find antenna azimuth and elevation settings for your location (*see page 4*).
- Test the DIRECTV System operation (*see page 5*).

How to use this manual

This manual uses these typographical conventions to help clarify instructions:

Text Example	Description
Click Cancel .	On-screen command buttons that execute an action.
Highlight the <i>Messages</i> button.	Selections or other option buttons within a menu pane.
Press the INFO button. Connect a pair of A/V cables to the AUDIO IN jack.	Remote control buttons, or receiver front panel. Names of equipment cable connections on equipment.
Highlight the Options tab.	Menu tab names.
Display the MAIN MENU .	Menu and pane names, names of pop-up and sub-menu panes.

Setup overview

At this point, you should have:

- Mounted the DIRECTV Satellite Antenna and pointed it in the general direction of the satellite.
- Grounded the antenna as described in your antenna installation instructions.
- Attached RG-6 coaxial cable(s) to the antenna LNB connector(s).
- Routed the other end of the antenna cable to the back of your DIRECTV Receiver.
- Placed the DIRECTV Receiver accessible to a telephone modular jack.
- Inserted the access card into your DIRECTV Receiver.

Ensure that you have completed these procedures, then continue to the next page to begin installing the DIRECTV Receiver.

Attach the satellite antenna cable

You can configure your system several ways, depending on what additional components (such as a VCR, DVD player, or A/V receiver) you select. For now, however, use the simplest configuration to check your antenna and cabling.

- Ensure that the DIRECTV® Receiver is **not** plugged into an electrical outlet.
- Attach the RG-6 coaxial antenna cable to the **SATELLITE IN** connector on the back of the DIRECTV Receiver. Refer to the appropriate figure below.

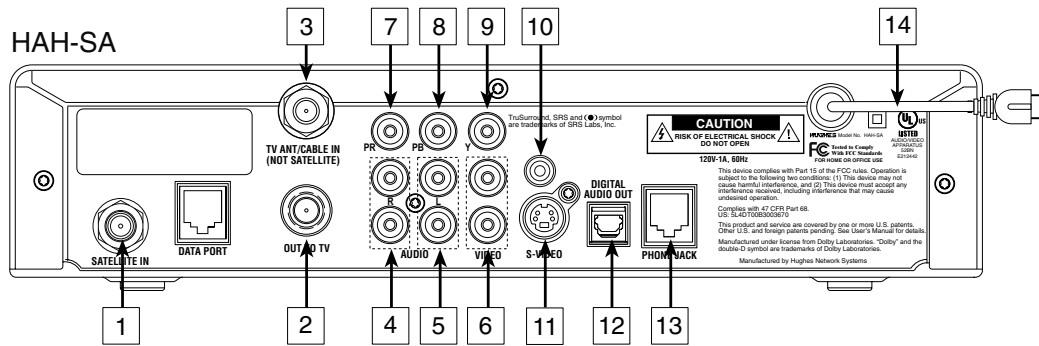

Table 1: Rear panel connections - DIRECTV Receiver model HAH-SA

1	SATELLITE IN connector	8	Pb component output jack
2	OUT TO TV connector	9	Y component output jack
3	TV ANTENNA/CABLE IN connector	10	VCR CONTROL cable jack
4	AUDIO OUTPUT (R) jacks	11	S-VIDEO jack
5	AUDIO OUTPUT (L) jacks	12	DIGITAL AUDIO OUTPUT optical jack
6	VIDEO OUTPUT jacks	13	TELEPHONE JACK
7	Pr component output jack	14	AC POWER CORD

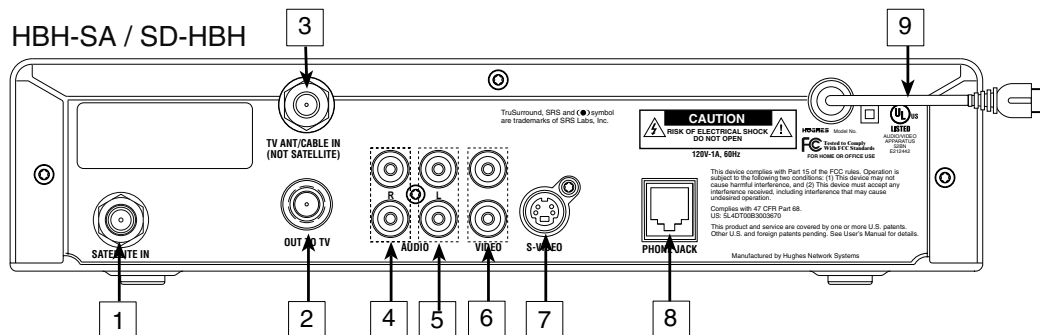

Table 2: Rear panel connections - DIRECTV Receiver model HBH-SA/SD-HBH

1	SATELLITE IN connector	6	VIDEO OUTPUT jacks
2	OUT TO TV connector	7	S-VIDEO jack
3	TV ANTENNA/CABLE IN connector	8	TELEPHONE jack
4	AUDIO OUTPUT (R) jack	9	AC POWER CORD
5	AUDIO OUTPUT (L) jack		

Connect your TV Depending on your TV, you can connect it to the receiver in one of four ways:

- Component (Y,Pb,Pr,-*HAH-SA only*) video cable (*best picture quality*) or
- S-Video cable (*excellent picture quality*) or
- Video cable (*very good picture quality*) or
- Coaxial cable (*good picture quality*)

You will also want to use a pair of audio cables (L/R) to provide stereo sound. If your TV does not have standard A/V jacks, you will hear monophonic audio. This is acceptable for the procedures described in the next section.

To connect your TV to the DIRECTV® Receiver:

1. Select the appropriate connection:

If your TV has component video jacks –

- Use a component video cable (not supplied) or supplied A/V cable to connect the DIRECTV Receiver's Y, PB, and PR output to the corresponding TV input jacks.
- Use supplied A/V cable to connect the DIRECTV Receiver's AUDIO (L/R) jacks to the TV's AUDIO IN jacks.

If your TV has an S-Video jack –

- Use an S-Video cable (not supplied) to connect the DIRECTV Receiver's S-VIDEO jack to the TV's S-VIDEO input jack.
- Use supplied A/V cable to connect the DIRECTV Receiver's AUDIO (L/R) jacks to the TV's AUDIO IN jacks.

If your TV has RCA-type A/V connectors –

- Use the supplied A/V cable to connect the DIRECTV Receiver's AUDIO and VIDEO jacks to the TV's A/V IN jacks.
- If your TV has only one AUDIO IN jack, connect the receiver's AUDIO L jack to the TV AUDIO IN jack.

If your TV only has an RF (coaxial) connector –

- Connect the DIRECTV Receiver's OUT TO TV connector to the TV's VHF/UHF IN or RF IN jack.

2. Connect one end of the telephone line cord provided into the DIRECTV Receiver's PHONE JACK.
3. Connect the other end into a modular telephone outlet.
4. Plug the TV into an electrical outlet.
5. Plug the DIRECTV Receiver power cord into an electrical outlet. If the front panel Power indicator does not illuminate, press the POWER button.

The data port (HAH-SA only) is used for diagnostic and aftermarket service. Professional installations using the data port must utilize a good quality shielded cable to ensure FCC compliance.

Determine antenna angles

This section explains how to determine the proper antenna position, expressed in degrees of *azimuth* (horizontal) and *elevation* (vertical). Use the receiver front panel controls shown below to complete this procedure.

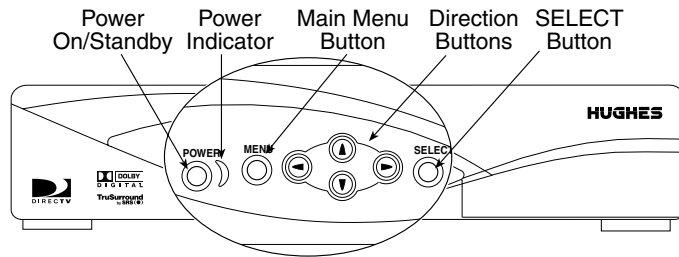

1. Press the front panel MENU button to display the **MAIN MENU** below.
2. Use the ▼ button to highlight the **System Setup** tab.

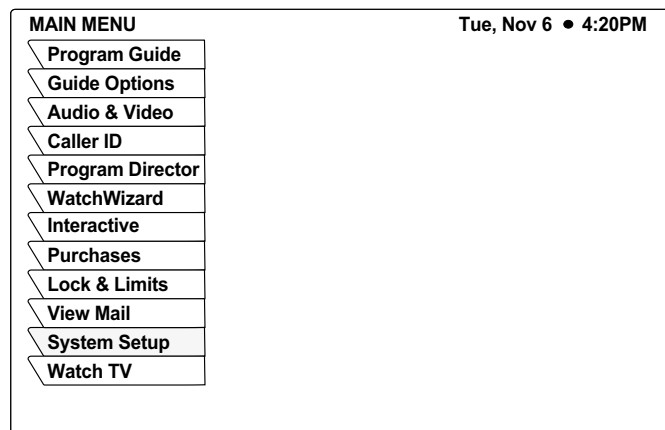

“Tilt angle” also appears if you have selected an Oval Antenna from the Dish Type menu.

3. Press the front panel SELECT button.
4. The **INSTALL** menu helps you to determine the correct antenna position using your 5-digit ZIP code. Enter your ZIP code and press **OK**.

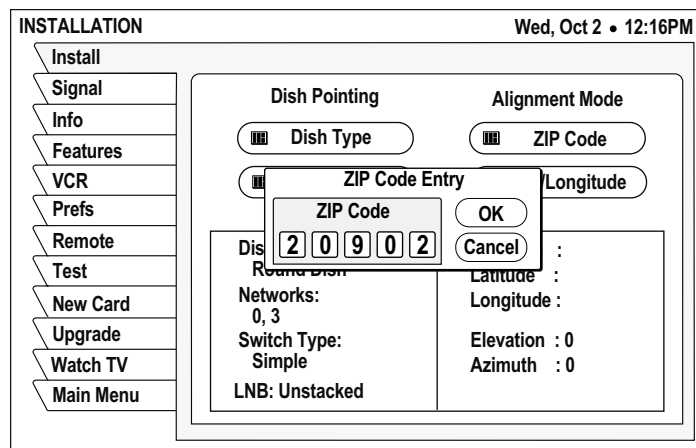

The correct azimuth and elevation angles will appear with onscreen instructions for using these values to properly align your dish antenna.

5. Highlight and SELECT the **Autoconfig** menu button to automatically set your receiver to work with these antenna values.

Testing your system

When you have aligned your dish antenna to the azimuth and elevation angles shown on the **Install** pane, highlight the **Signal** tab. Signal quality is indicated by a scale at the bottom of the pane and with an audible indication. The frequency and tempo of the tone increase with signal strength.

To perform the Transponder test:

Use this procedure to test the signal strength from the satellite transponder:

1. Select the **System Setup** tab from the **MAIN MENU**
2. Highlight the **Signal** tab to display the **SIGNAL STRENGTH** menu pane.
3. Highlight the **Test** menu button as shown in the figure below.

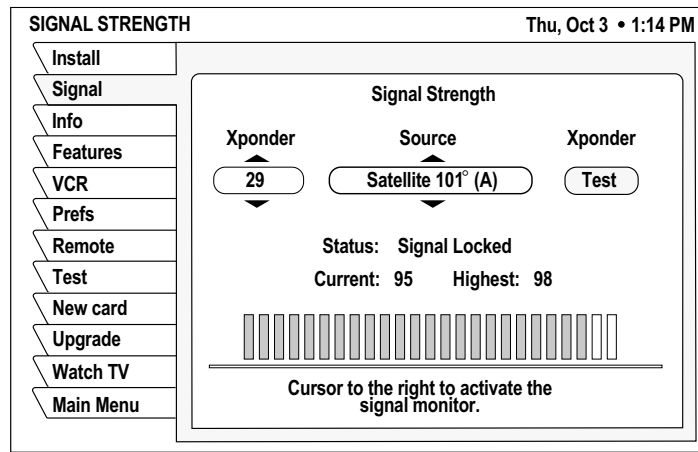

4. Press SELECT to display the Transponder Test menu (see figure below).
5. Press SELECT to begin the test on the highlighted selection.

Note: *Xponder* and *Source* selections displayed may vary from those shown.

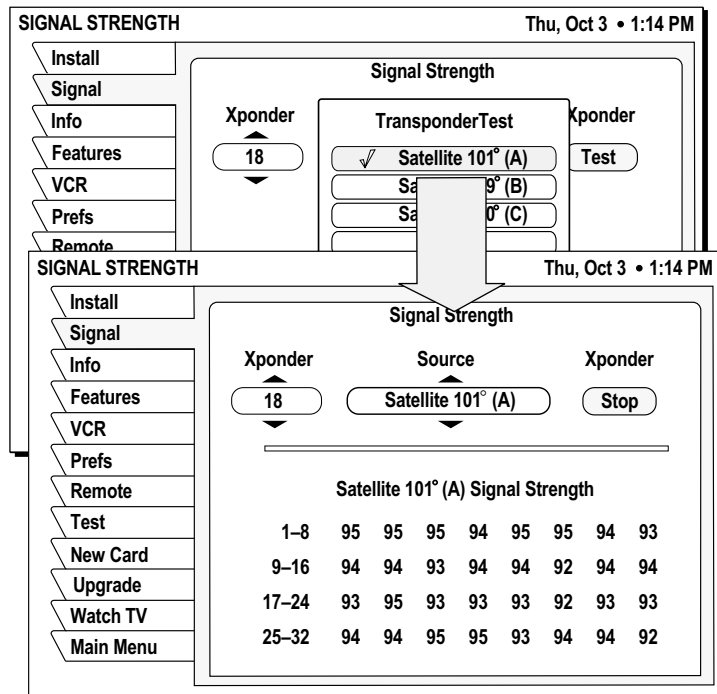

An occasional "0" indication may be considered normal.

Results should generally resemble those in the figure, but the actual values will vary somewhat from those shown in the figure depending on your geographic location and specific installation. However, if your results are *very* different from these examples (i.e, rows of zeros or single-digit numbers) or you receive no signal indication:

- Highlight the **Install** tab on the **INSTALLATION** menu. Verify your settings.
- Re-enter your ZIP code if necessary to verify you have used the correct antenna pointing parameters for your location.
- Check your cable connections.
- Ensure the DIRECTV® Receiver is connected to a modular telephone jack.

Once you have successfully obtained a signal and your test results resemble those shown in the figures, call DIRECTV (or your subscription service provider) to activate service if you have not already done so.

You can configure your DIRECTV® Receiver several ways depending on the additional audio/video components you want to use.

This chapter explains how to:

- Connect a terrestrial (broadcast) TV antenna (*this page*).
- Connect and set-up a VCR (*see page 8*).
- Integrate a DIRECTV Receiver into your audio or A/V system (*see page 9*).

Connecting additional system components

At this point, you should have:

- Verified that your system is operating properly.
- Connected your DIRECTV Receiver to your TV.
- Unplugged all components from electrical outlets.

Connecting a terrestrial antenna/CATV

You can connect a terrestrial (broadcast) TV antenna or CATV to your DIRECTV Receiver by connecting it to the DIRECTV Receiver's TV ANT/CABLE IN jack (see figures on page 2). The remote control INPUT button allows you to switch between DIRECTV® programming and input from the terrestrial antenna or CATV.

Connecting a VCR

Follow these instructions to connect your TV and VCR to the DIRECTV® Receiver. Connect the satellite antenna RG-6 coaxial cable to the DIRECTV Receiver's SATELLITE IN jack (see figures on page 2).

1. Depending on your VCR, select the appropriate connection to the DIRECTV Receiver:

If your VCR has A/V connectors –

- Connect the DIRECTV Receiver's AUDIO and VIDEO jacks to the VCR's A/V IN jacks.
- If your VCR has only one AUDIO IN jack, connect the receiver's lower (mono) AUDIO L jack to the VCR's AUDIO IN jack.

If your VCR only has an RF (coaxial) connector–

- Connect the DIRECTV Receiver's OUT TO TV connector to the VCR's VHF/UHF IN or RF IN jack.

2. Depending on your TV and VCR, select the appropriate method to the connect the VCR to the TV:

If your TV and VCR have A/V connectors –

- Connect the DIRECTV Receiver's AUDIO and VIDEO jacks to the corresponding A/V IN jacks on your TV.

If your TV or VCR only has an RF (coaxial) jack –

- Connect the VCR's VHF/UHF OUT jack to the TV's VHF/UHF IN jack.

3. Plug the TV, VCR, and DIRECTV Receiver power cords into an electrical outlet.

Connect the VCR Control Cable (Model HAH-SA only) The DIRECTV® Receiver can control your VCR for unattended recording, using the VCR Control Cable provided.

1. Plug the VCR control cable into the rear panel VCR CONTROL jack.
2. Temporarily position the other end over the VCR's remote control sensor (normally a small dark plastic window on the VCR front panel).

The remote control sensor may be labeled or identified in your VCR manual. If it is not identified, scan the front of the VCR with your VCR remote control:

3. Hold the VCR remote control about ½-inch (1.3 cm) from the front left side.
4. Slowly move the remote control to the right as shown in the figure.
5. Repeatedly press the VCR remote control's power key on and off.

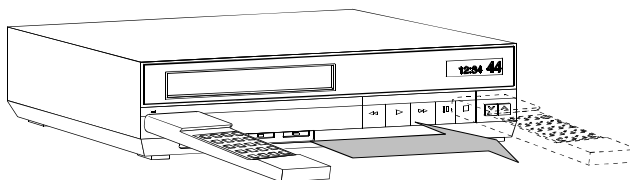

Scanning for the VCR remote control sensor

6. When your VCR responds to your pressing the remote control power, note the position. Temporarily tape the IR emitter to the position you marked until you verify that it works properly.

Test the VCR (Record/Stop) This Record/Stop test verifies the specified brand and code controls your VCR.

1. Turn the VCR power on.
2. Insert a recordable videotape into the VCR.
3. Using the satellite receiver front panel buttons, (*don't* use the remote control) SELECT the **VCR** tab from the **SYSTEM SETUP** menu.
4. Highlight and SELECT your VCR brand as shown below.

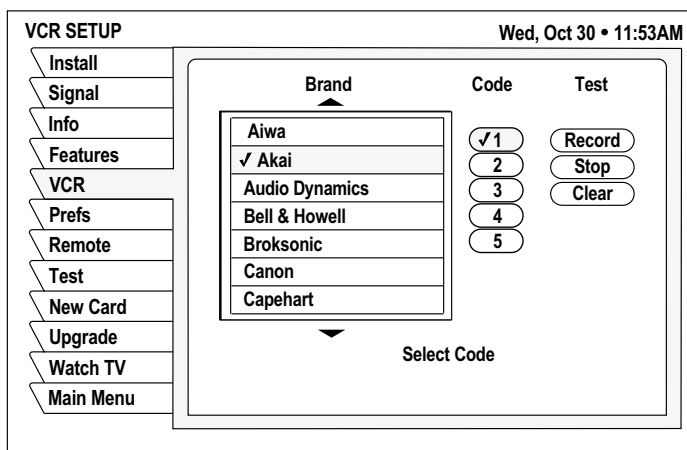

5. SELECT the highlighted Code menu button.
6. SELECT the **Record** menu button under the Test column.
7. Verify the VCR is recording.
8. SELECT the **Stop** menu button.

If either command does not function, try other codes listed for your VCR brand. If you are unsuccessful after trying *all* available codes, recheck your VCR Control Cable connections and IR emitter placement.

9. Remove the temporary mounting tape. Attach the emitter permanently using the peel-and-stick backing. This will not interfere with normal VCR operation.

Connecting a home entertainment system

You can integrate the DIRECTV® Receiver into your entertainment system to take advantage of enhanced audio and video capability. Follow these instructions to connect your DIRECTV Receiver.

*The A/V receiver **must** be turned on in order to send the video and video signal to your TV.*

- To connect the DIRECTV Receiver to your audio system, use A/V cables to connect the satellite receiver to the audio receiver's AUDIO IN jacks.
 - Dolby Digital - With the HAH-SA satellite receiver, you can enjoy programs that contain a Dolby Digital sound track. We recommend that you listen in surround sound for maximum enjoyment of these programs. You can connect the stereo outputs of the HAH-SA to a receiver that contains a Dolby Surround Pro Logic decoder. This will provide you with three audio channels in the front and a mono surround channel.
 - To take full advantage of Dolby Digital programming, connect the HAH-SA digital audio output to an external *5.1-channel* Dolby Digital decoder or receiver. This provides you with three front channels, two independent surround channels, and an LFE (or subwoofer) channel.
1. Connect the satellite antenna RG-6 coaxial cable to the DIRECTV Receiver's SATELLITE IN jack.
 2. Connect the DIRECTV Receiver's A/V jacks to the VCR and A/V receiver's A/V jacks.
 3. *AUX, optical connection, and digital output connections* – If your audio receiver has optical digital connectors, connect the appropriate type of cable to the DIRECTV Receiver's DIGITAL AUDIO OUT for two-channel digital stereo. If your A/V receiver is also capable of decoding Dolby Digital, use this connection in order to listen in full 5.1-channel surround sound. Refer to page 25 for additional audio information.
 4. Connect the VCR's A/V OUT jacks to a pair of the A/V receiver's A/V IN jacks.
 5. Connect the A/V receiver's MONITOR OUT jack to the TV's VIDEO IN jack.
 6. Plug the components into an electrical outlet.

Note: If you have connected a VCR to your entertainment system in a way that routes the satellite receiver's signal to your VCR before it reaches the TV, you may see a distorted picture if you try to record (or view in some instances) a copy-protected program. A *Can't Tape* symbol in the screen banner identifies these programs.

This chapter explains how to:

- Use the HRMC-11, HRMC-12, and HRMC-13 remote control functions. (see page 13)
- Program the remote to work with other system components. (see page 14)
- Install and replace the remote control batteries. (see page 15)

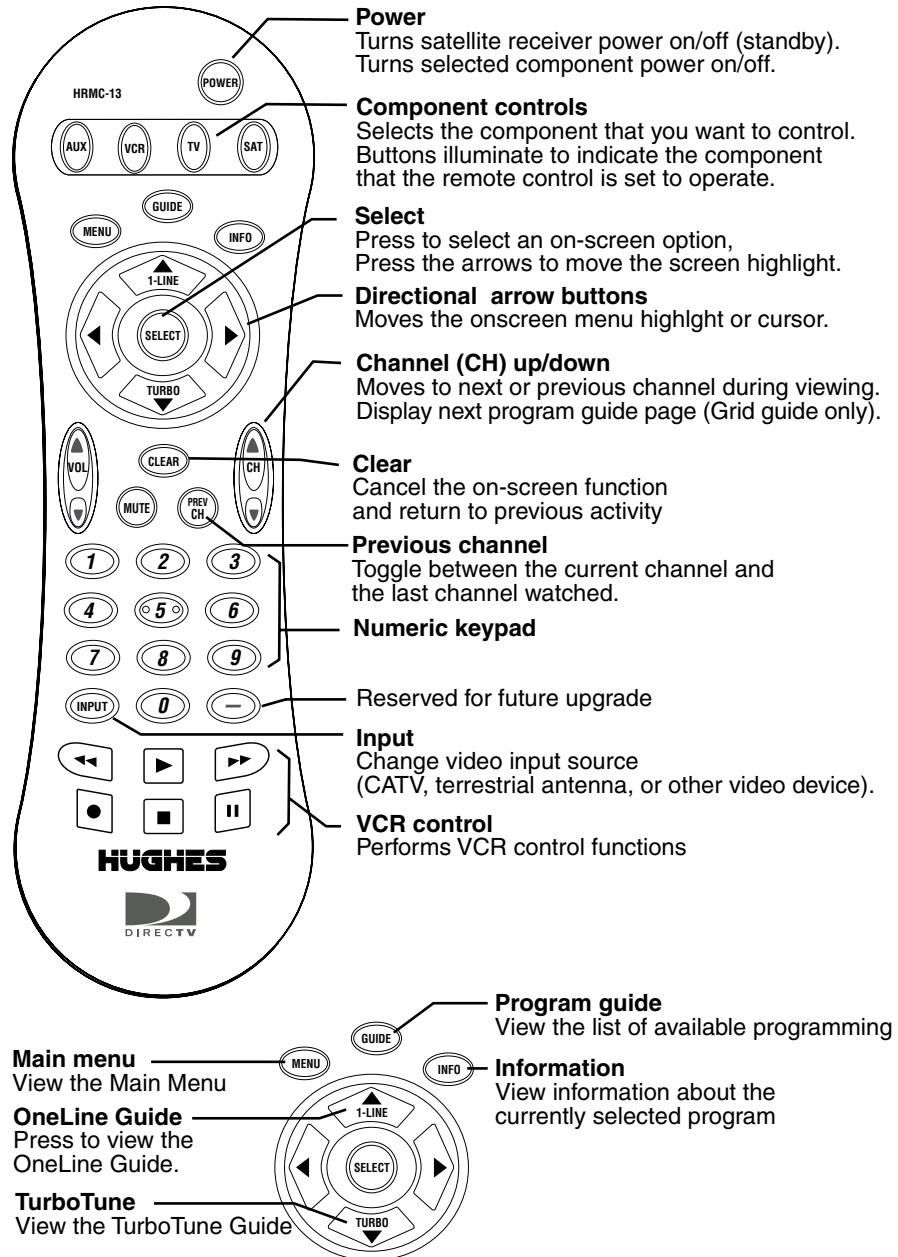

HRMC-13 Remote Control Function Quick Reference

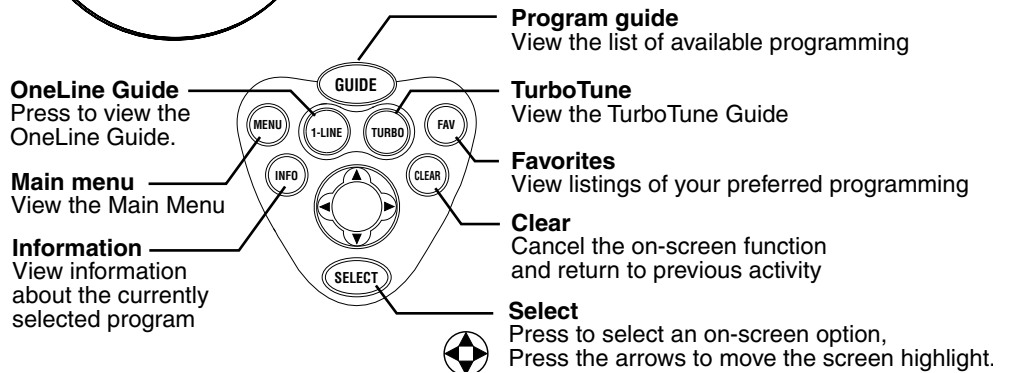
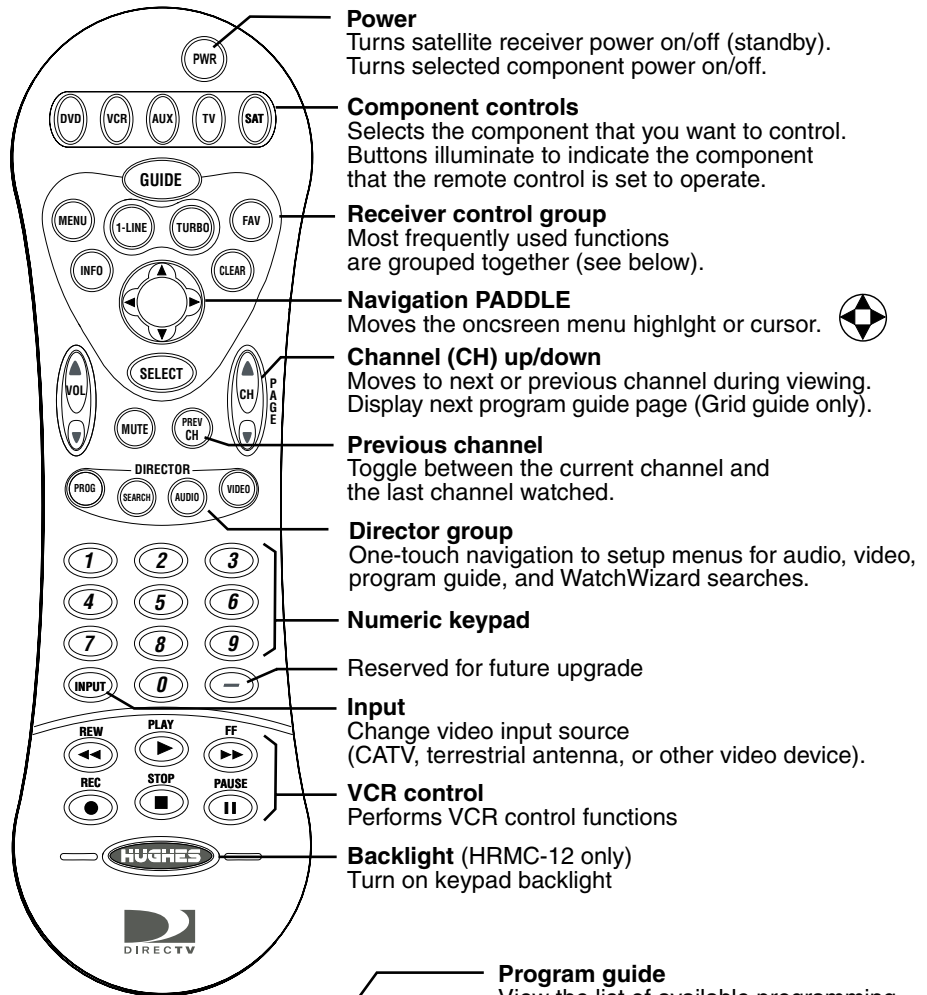

HRMC-11 and HRMC-12 Remote Control Function Quick Reference

The DIRECTV® Receiver front panel buttons provide the basic controls needed to access major DIRECTV System features. However, using the remote control simplifies accessing the basic system functions, enhances your system's capabilities, and provides convenient shortcuts to extended features. Additionally, most remote control buttons can also control other home entertainment system components.

Remote control functions

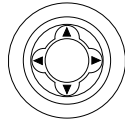

Use the directional paddle or directional arrow buttons to move up, down, left, or right through the on-screen displays. This  icon appears throughout this manual to instruct you to use the paddle or directional arrow buttons to navigate through on-screen menus and guides.

Pressing the paddle or directional arrow buttons left or right while watching a program displays the *Alternate Audio* selection popup menu.



Press the SELECT button to activate or choose a highlighted menu option.



Press the GUIDE button to display the current program guide. Press it a second time (while a program title is highlighted) to display the **Category Filter** menu.



Press the INFO button to display a brief description about the program you are viewing. For more details, press it again to display the *Information Banner*. The INFO button provides scheduling information (and pay per view purchase information) about the program highlighted in the program guide.

See Chapter 4 – *Using program guides*, on page 17 for more information.



Use the CHANNEL (CH) button to move up or down to the next available channel or scroll through a page of program guide selections



Press the CLEAR button to exit from any on-screen guide, remove banners, or cancel an action.

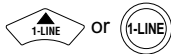

Press the 1-LINE button to display the OneLine™ guide. When the OneLine is onscreen, pressing the 1-LINE button again adds another line to the guide, up to four lines (applies to HRMC-11 and HRMC-12 only). When the OneLine guide appears, press the  paddle or directional arrow buttons up or down to step to the next higher- or lower-numbered channel.

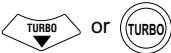

Press the TURBO button to display the TurboTune™ menu guide (HRMC-11 and HRMC-12 only).



The INPUT button allows you to select programming from additional program sources such as a DVD player, VCRs, or a terrestrial TV antenna signal. Repeatedly press INPUT to cycle through each available input source in your system.



Press the SAT component select button to control the DIRECTV® Receiver. The other component select buttons indicate the devices they control. You can program the AUX button to control another digital device such as an audio CD player.



The DIRECTOR buttons provide convenient shortcuts to the Program Director, WatchWizard™, audio, and video adjustment menus (HRMC-11 and HRMC-12 only).

Programming the remote control

You can operate your TV, VCR, SAT, AUX device, or DVD (HRMC-11 and HRMC-12 only) devices using your remote control. Use the *Code Entry* or *Code Scanning* method to program the remote control. Using the Code entry method may be quicker, but you'll need to know the correct manufacturer's control codes for each component you want to operate. Code scanning may be more time-consuming, but you don't need to know manufacturer's control codes.

1. Keep your remote control aimed at the device you want to control during this process. The remote control will send out the "power" command for the device being programmed.
2. Press and hold the device key (for example, TV)
3. Press press the MUTE key for two seconds.
4. Release both keys.

The device key should light and remain lit. If it doesn't remain lit, repeat steps 1 through 4 above.

5. Choose one of the programming methods described below:

Code Entry Use the **REMOTE** pane under the **System Setup** menu tab to program your HRMC-11, HRMC-12, or HRMC-13 remote control to operate your TV, VCR, SAT, AUX device, or DVD (HRMC-11 and HRMC-12 only). The AUX menu button can be used to control a CATV box or other type of device. Use the menu buttons to choose the desired type of device and display a brand name menu list from which you can select the manufacturer of your device.

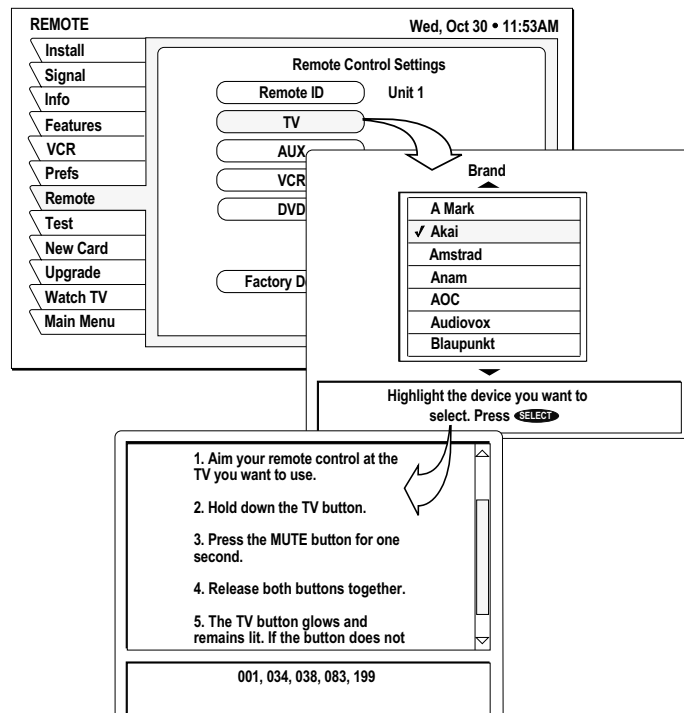

Device codes appear in the menu pane for the brand selected. Step-by-step onscreen help guides you through the procedure. Appendix B – *Manufacturers device control codes*, on page 41 also provides a complete list of device codes.

Code Scanning



To use the Code Scanning method:

1. Repeatedly tap the top part of the CHANNEL (CH) button.
2. Continue to step through the codes until the component turns off, indicating you have found the correct component code. If you accidentally pass a code that responds or realize you may not have been aiming the remote control at the component, tap the lower part of the CHANNEL (CH) button to step backward through the codes.
3. Press the remote control POWER button to verify the proper code by turning the device on and off.
4. Press the device button (in this example, TV) again to lock in the code.

Changing the Remote ID

If you are using multiple satellite receivers in the same room, you may want to change the remote control ID to avoid interference or “cross talk.” The remote control ID can be a number from “001” to “008”.

If you change remote IDs, set your remote control to that ID number *first*. Use this procedure to set the remote control to use a different remote ID:

1. From the **MAIN MENU**, highlight the **System Setup** menu tab. Press **SELECT**.
2. Highlight **Remote** menu tab to access Remote Control Settings.
3. Highlight the **Remote ID** menu button.
4. Press and hold the remote control **SAT** button.
5. Press and release the **MUTE** button.
6. Release the **SAT** button. It should remain lit. If it does not, repeat steps 4-6.
7. Enter desired number (001 to 008).
8. Press the **SAT** button to lock in the code.
9. Point the remote control at the receiver. Press **SELECT**.

The number to the right of the highlighted **Remote ID** menu button will change to the new code. Check that the ID has been successfully set by testing the remote control to see that it controls that satellite receiver.

Installing remote control batteries

To install or replace the remote control batteries:

1. Locate the battery compartment on the back of the remote control.
2. Remove the battery compartment cover.
3. Insert two “AAA” size batteries as shown, observing the correct polarity.
4. Replace the battery compartment cover.

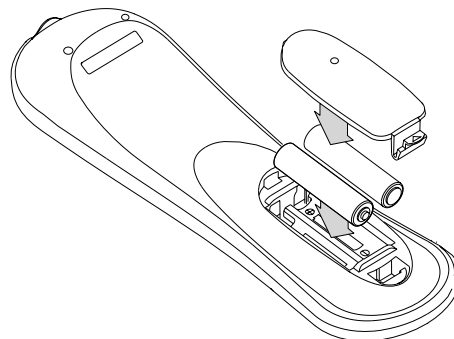

This chapter describes:

- The different program guide styles (*this page*).
- Common program guide and menu features (*see page 19*).
- How to use the OneLine™ Guide (*see page 20*).
- How to set-up and use the TurboTune™ Guide (*see page 20*).
- Using DIRECTV INTERACTIVE™ (*see page 21*)
- Setting program guide preferences (*see page 22*)

Selecting a program guide style

Personalize the program guide to show program listings that interest you. You determine how your choices appear on-screen by your guide selection. Available guide styles are:

- **Grid** with Picture-in-Guide and description, or description only
- **Logo** with Picture-in-Guide and description, or description only

To select a guide style:

1. Press the remote control GUIDE button twice to display the **GUIDE OPTIONS** menu.
2. Highlight the **Options** menu tab.
3. Use the  paddle or directional arrow buttons to highlight the **Guide Style** menu button.
4. Press the SELECT button on the remote control toggle between *Grid* and *Logo* guide styles.
5. Press the CLEAR button on the remote control to return to the program you were viewing.

Cells with arrows indicate the program started at an earlier time or continues later than can be shown in the selected time period..

Grid guide

- Easy to see what programs are available at a particular time.
- Browse up or down one channel at a time with the  paddle or directional arrow buttons when the highlight is in the grid.
- Shows up to 3 days (*SD-HBH Model*) 7 days (*HBH-SA model*) or 14 days (*HAH-SA model*) of current and upcoming programming,

Press the remote control GUIDE button while the program guide appears on-screen to display the Guide Options menu.

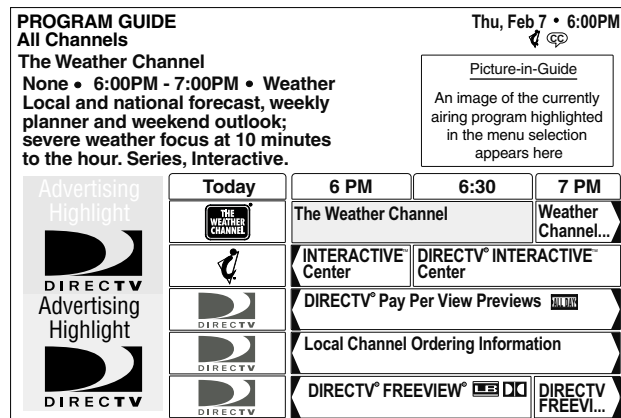

If program information cannot entirely fit in the space provided, an ellipsis (...) indicates that a portion of the title is not shown.

Press the remote control INFO button to view complete program information.

- Use the remote control CHANNEL(CH) button to scroll through a full page of guide entries at a time.
- Active ad highlights provide “one-click” access to products and services. Move the highlight to the right to show future programming. Press the remote control INFO key for a full description of the highlighted program.
- Move the highlight into the Channel Tag column (left side of guide) to temporarily view the current program on that channel in the Picture-in-Guide window. Optional *Picture-in-Guide* feature displays video of the current program in the upper right corner of the screen.

You can view video (if the Picture-in-Guide is turned off) when using guides and menus by increasing *Translucency* using the **VIDEO ADJUSTMENT** menu.

Logo guide

- Select your favorite channels, rather than selecting specific programs. Only current programming can be selected from the Logo Guide.
- The current program title and a description appears above the logo grid as you highlight each channel.
- Video of the current program appears in the Picture-in-Guide window as you highlight each channel.

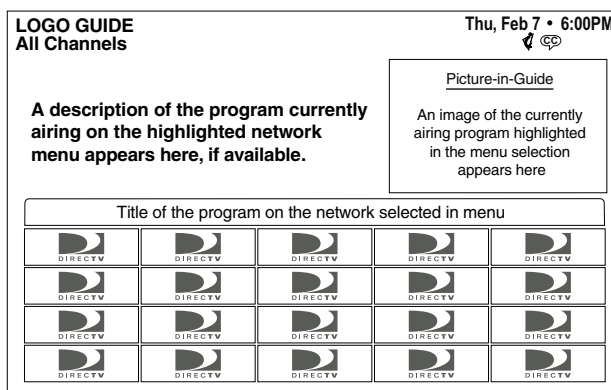

Logo guide with Picture-In-Guide active

Program guide and menu features

The on-screen guides and menus provide a logical and convenient way to access system features and settings. Every guide and menu contain these elements:

- The guide or menu title
- The day of the week, date, and time appear in the upper right corner
- Menu pane selection tabs

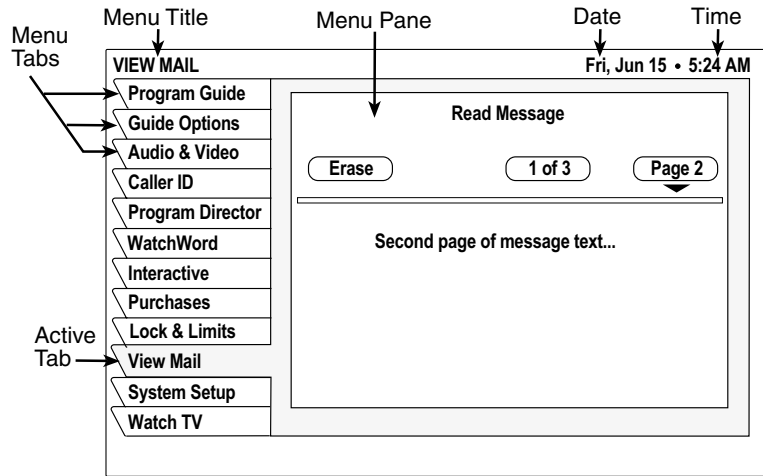

Use the paddle or directional arrow buttons to move the highlight from tabs into menu panes.

- Below the date and time, small icons indicating the status of the system or details about the currently highlighted program title may appear. These icons also appear in the *Channel Banner* as shown below.

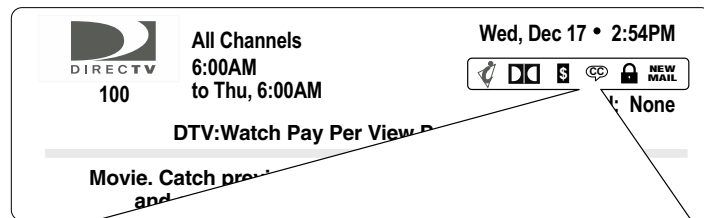

Icon	\$				NEW MAIL			CAN'T TAPE	ALT. AUDIO	DATA SVCS.	ALL DAY	LB
Meaning	Pay per view	Interactive programming available	Dolby Digital audio available	Closed caption available	Unread mail	Limits enforced	Limits override	Taping not allowed	Other audio available	Data available	All Day Ticket	Letter Box format

The Channel Banner appears at the top of the screen when you tune to a channel or press the INFO button on the remote control while viewing video. You can select a *Short* or *Full* banner using the **PREFERENCES** menu from the **System Setup** tab. The short/full banner feature only affects banners displayed when changing channels.

Press the remote control INFO button to display a Full banner at any time.

Banners disappear from the screen after a few seconds, but you can remove them from the screen instantly by pressing the CLEAR button on the remote control.

Using the OneLine™ Guide

The OneLine™ Guide appears across the bottom of your screen when you press the 1-LINE button while watching TV. You will see the channel call sign and number, titles, and program start and end times as shown below.

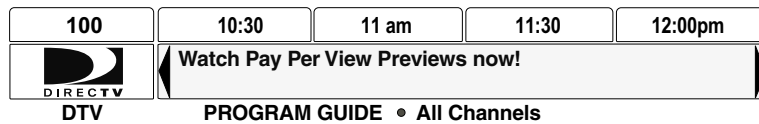

- Pressing the 1-LINE button while the OneLine guide is on-screen adds an additional line to the guide (up to four lines).
- Use the paddle or directional arrow buttons to scroll to the right to see upcoming program titles.
- Display current or future program information in the Channel Banner by pressing the remote control INFO button.
- Use the paddle or directional arrow buttons to move up or down while using the OneLine Guide to see the next or previous available channel. Press SELECT to tune to the channel.
- You can also enter a channel number using the numeric keypad to display the OneLine Guide for that channel. OneLine Guide content varies according to **FAV LIST** menu selections and other filters.
- Press the CLEAR button on the remote control to instantly remove the guide.

Using TurboTune™

The TurboTune™ feature is a quick access guide to 27 of your favorite channels. Three groups of nine of your favorite channels are available as *Turbo 1*, *Turbo 2*, and *Turbo 3*.

1. Press the TURBO button on the remote control to show the TurboTune grid shown in the figure below.
2. Use the paddle or directional arrow buttons to highlight an unused position (*Add Channel*) of the TurboTune grid.
3. Press SELECT to add the channel you are watching to the TurboTune menu.

Press the TURBO button to cycle through Turbo1, Turbo 2, and Turbo 3 program groups when the TurboTune guide is on-screen.

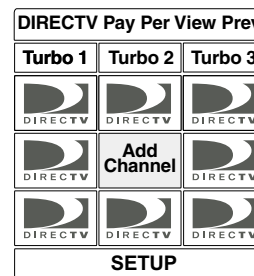

Setting TurboTune channels:

1. SELECT **Guide Options** from the **MAIN MENU**, then use the **Set Turbo** menu tab or press the TURBO button on the remote control then SELECT the **Setup** pane below the TurboTune Menu.
2. Highlight an unassigned channel box (*Add Channel*) and press SELECT.

- Choose the desired channel in the setup box shown below using the  paddle, directional arrow buttons, or the CHANNEL(CH) button.

You can also use the numeric remote control buttons to enter specific channel number.

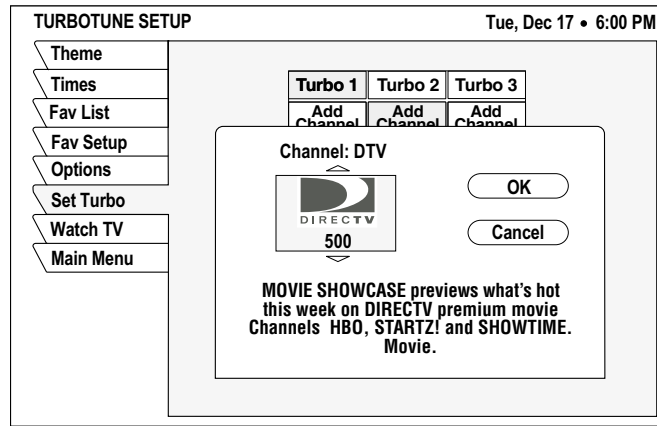

Renaming TurboTune groups: Each nine-channel group can be renamed as anything you choose, using up to 10 letters, numbers, spaces, and punctuation. From the TurboTune grid:

- Highlight the grid name (*Turbo 1*, *Turbo 2*, or *Turbo 3*) shown above.
- Press **SELECT**.
- Use the on-screen keyboard to enter the new name.
- Highlight and **SELECT** the **OK** menu button.

Use the **Cancel** or **Clear** menu buttons to redo the entry or cancel the change.

Using DIRECTV INTERACTIVE™ powered by Wink Communications®

Select the **DIRECTV INTERACTIVE Center** menu bar, then follow the simple directions provided on the subsequent screens.

DIRECTV INTERACTIVE™ powered by Wink Communications® is a free, easy-to-use service that allows you to interact with the television shows and advertisements. When the blinking  symbol appears on your screen, you know that the program you're watching has been enhanced with DIRECTV INTERACTIVE Service. Press the **SELECT** button on your remote control to access interactive features.

You can use your remote control to access up-to-the-minute sports scores, news and weather, get program trivia, respond to offers during commercials, and purchase products, all while watching TV.

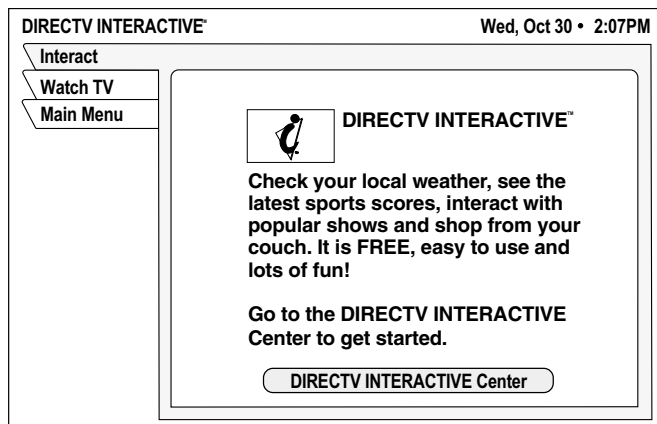

Setting guide preferences

The **GUIDE OPTIONS** menu shown below allows you to customize the appearance and behavior on-screen guides. To set guide preferences:

1. Highlight and **SELECT** the **Guide Options** tab from the **MAIN MENU**, or press the remote control **GUIDE** button twice while watching a program.
2. Highlight the **Options** tab
3. Highlight and **SELECT** the menu button for the setting you wish to modify.

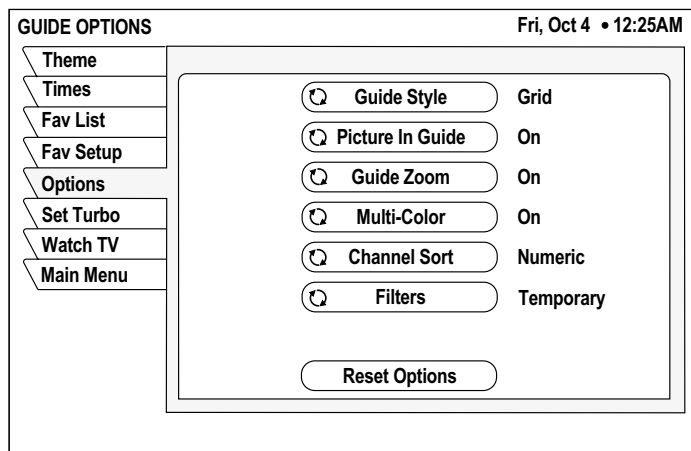



This chapter describes:

- How to find the menus you need to perform common tasks (*this page*).
- How to purchase pay per view events (*see page 24*).
- Using the Program Director (*see page 28*).
- How to set and modify preferences (*see page 25*).

The table below lists the **MAIN MENU** tabs, their submenus, and what they do.

Main Menu tab	Screens (see page)	If you want to:
Program Guide	Program Guide	<ul style="list-style-type: none"> • View, and modify the program guide.
Guide Options	Theme (<i>page 35</i>) Times (<i>page 36</i>) Favorites List (<i>page 33</i>) Favorites Setup (<i>page 33</i>) Set Options (<i>page 25</i>) Set Turbo (<i>page 20</i>)	<ul style="list-style-type: none"> • Filter the program guide. • Change the period of time shown in the program guide • Select a specific channel list (Fav. A, Fav. B, Fav. C, Family, and New Channels) to be an active program guide. • Create/Edit a channel list (Fav. A, Fav. B, Fav. C, Family, and New Channels) that contains selected channels. • Guide Options: <ul style="list-style-type: none"> – Guide style (grid or Logo) – Picture in guide, zoom (on or off) – Multi-Color guide (on or off) – Channel Sort (numeric or alpha) – Filters, (temporary or persistent) – Reset options to the default selections • Set and edit TurboTune channels
Audio & Video	Audio Adjustment (<i>page 25</i>) Video Adjustment (<i>page 26</i>)	<ul style="list-style-type: none"> • Set Default Audio language and Alternate Audio language • Set left/right audio balance • Select 4:3 or 16:9 screen ratio • Center menus on your monitor (up/down and right/left) • Color scheme, color balance, and on-screen display translucency
Caller ID*	Caller ID (<i>page 31</i>)	<ul style="list-style-type: none"> • See the names and telephone numbers of recent callers
Program Director	Schedule (<i>page 28</i>)	<ul style="list-style-type: none"> • Automatically tune to programs for viewing or taping
WatchWizard	Setup (<i>page 27</i>) Results (<i>page 27</i>)	<ul style="list-style-type: none"> • Search for programming using specific words and other criteria • Display search results
Interactive	DIRECTV INTERACTIVE™ (<i>page 21</i>)	<ul style="list-style-type: none"> • Access interactive programming features
Purchases	Upcoming & Past Purchases (<i>page 24</i>)	<ul style="list-style-type: none"> • View a list of scheduled pay per view event • Display recently purchased pay per view events
Lock & Limits	Lock (<i>page 37</i>) Fav Setup (<i>page 33</i>) Rating (<i>page 37</i>) Limits (<i>page 38</i>)	<ul style="list-style-type: none"> • Lock and unlock the system • Set viewing times and maximum viewing hours • Set maximum program rating allowed for viewing • Create a program listing containing only selected channels • Filter programming content in the program guide
View Mail	Mail (<i>page 31</i>)	<ul style="list-style-type: none"> • Read messages from DIRECTV
System Setup	Install (<i>page 2</i>) Signal (<i>page 5</i>) VCR (<i>page 8</i>) Prefs (<i>page 30</i>) New Card Upgrade Features	<ul style="list-style-type: none"> • Determine proper antenna azimuth and elevation setting • Test signal reception • Setup VCR for unattended recording • Prepare a new access card • Display upgrade status and history • Adjusting user-selectable system settings • Display current receiver feature

Onscreen menu icons These icons appear in onscreen menus and are used throughout this manual:

-  **Toggle or Step** – Press SELECT to toggle (switch) a setting from “ON” to “OFF” or step through the available choices each time you press SELECT.
-  **List of Options** – Menu button will display a list of choices in a pop-up menu when you press SELECT.
-  **Series of Boxes** – Multiple screens will appear in a series requesting you to enter numbers and/or letters for the particular feature when you press SELECT.

Purchasing pay per view (PPV) events

If you are not authorized for purchases using your DIRECTV® Receiver, contact DIRECTV for assistance.

To purchase a pay per view event:

1. Highlight and SELECT the PPV event you wish to purchase.
2. Press SELECT to display the **PROGRAM INFORMATION** screen below.
3. SELECT the **Buy** menu button.
4. Press SELECT again to confirm your purchase. You can also cancel the purchase at this time if you change your mind.

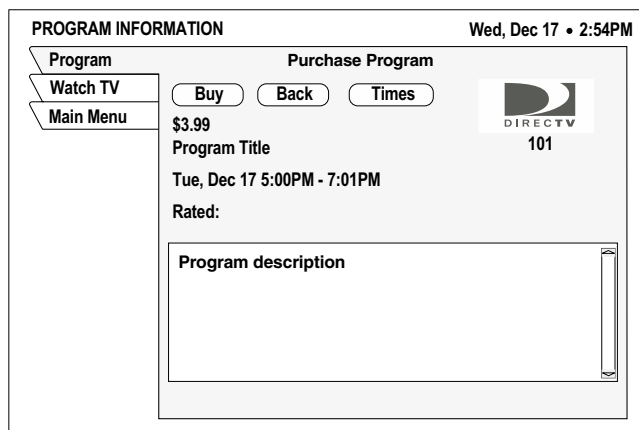

Cancelling purchases You can usually cancel unviewed purchases, however *some* events cannot be cancelled. If the **Cancel Purchase** button appears, you can clear the purchase. If this button is unavailable, part of the event has probably already been viewed, and you must accept the purchase.

To cancel a Pay Per View event:

1. Highlight the event you want to cancel.
2. SELECT **Cancel** on the **Purchase Confirmation** panel.

SELECT the **Purchases** menu tab to display lists of recently viewed and advance purchased pay per view events. You can choose **UPCOMING PURCHASES** and **PAST PURCHASES**. The event channel, title, start date and time, and cost is shown for each purchase.

Reviewing past purchases The **PAST PURCHASES** pane shows recent pay per view events charged to your account. You cannot remove listed events. The list does **not** show:

- events purchased, but later canceled.
- purchased, cancelable events to which the DIRECTV Receiver never tuned.
- events ordered by calling DIRECTV.

Listing unviewed purchases

The **UPCOMING PURCHASES** pane displays PPV events you have purchased but not yet viewed. Events ordered by calling DIRECTV do **not** appear on this list. For additional information about a specific event, highlight the event and press the INFO key.

Adjusting audio settings

Press the AUDIO button on your remote control or highlight and SELECT the **Audio & Video** tab from the **MAIN MENU**.

From the **AUDIO ADJUSTMENT** menu pane, you can:

- select default audio and alternate audio
- enable TruSurround® audio processing
- enable and configure Dolby Digital output (*Model HAH-SA only*)
- adjust audio left/right balance

Setting default and alternate audio

Your DIRECTV® Receiver supports alternate audio services. This **ALT. AUDIO** icon appears below the date and time in the Information Banner or program guide to indicate alternate audio is available for a particular program.

You will hear the **Default Audio** language all the time if that language is being transmitted and an alternate language has not been activated. If your selected default language is not being transmitted for a program, you will hear the language in which the program is broadcast.

If the **ALT. AUDIO** icon appears below the date and time in the Information Banner or program guide, pressing the navigation  paddle or directional arrow buttons left or right (while you are viewing a program) presents you with an alternate available language option based your **Alternate Audio** menu selection. Press SELECT to listen to program in the alternate language on the currently airing channel. Audio will revert to your selected **Default Audio** language when you change the channel.

*Occasionally, an audio track may be offered that is not being broadcast, in which case the audio will not change or you will not hear any audio. Change channels to restore the audio track to the one specified on the **AUDIO ADJUSTMENT** menu.*

To set up your default and alternate audio languages:

1. Press the remote control AUDIO button to access these services.
2. Highlight the **Default Audio** (to set your preferred primary language) menu button or the **Alternate Audio** menu button (to select your secondary language preference).
3. Highlight the desired language for the default or alternate language and press SELECT.

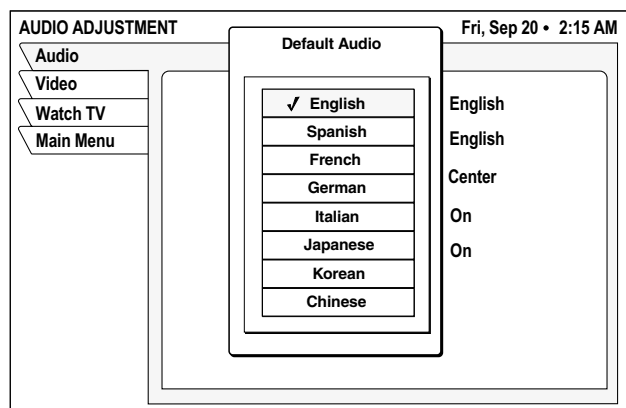

Using TruSurround

TruSurround technology lets you take advantage of any multichannel format without having to add extra speakers or equipment. Using two speakers, TruSurround “virtually” places the individual audio channels where they are supposed to be, as though you had speakers all around you. To enable TruSurround, set the SRS TruSurround menu button “On”.

Note: TruSurround and Dolby Digital are mutually exclusive features. TruSurround is unavailable when the receiver is decoding a Dolby Digital (AC-3) audio track.

Using Dolby Digital audio

(*Model HAH-SA only*) If you want the receiver to automatically decode Dolby Digital (AC-3) audio when available in selected programming, set the **Dolby Digital** menu button “On.” If your A/V receiver is Dolby Digital-capable, set the **Digital Output** menu button to “Dolby Digital.” Highlight and SELECT the **Dolby Digital Options** menu button.

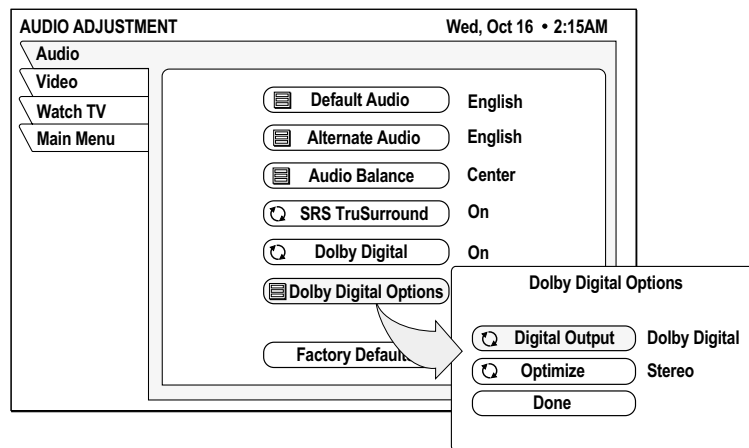

Set the **Digital Output** menu button for “Dolby Digital” as shown in the figure.

If your A/V receiver cannot decode Dolby Digital audio, use the “PCM” (two-channel) setting. Use the **Optimize** “Mono” setting if you connect the satellite receiver to your TV using coaxial cable without A/V (left/right audio) cables.

Adjusting video settings

Press the AUDIO button on your remote control or highlight and SELECT the **Audio & Video** tab from the **MAIN MENU**.

From the **VIDEO ADJUSTMENT** menu pane, you can:

- change the screen aspect ratio - 4:3 or 16:9
- center the on-screen menu
- select a different menu color scheme - *Indigo, Ice, Sky, Forest, or Merlot*
- adjust the amount of menu translucency - from Solid to 100% Translucent
- adjust image brightness, contrast, and saturation
- enable or disable black level filtering

Using WatchWizard™

WatchWizard™ allows you to search for programs using criteria such as rating, showtime, language, and category. You can search for a specific word used in program titles or descriptions.

WatchWizard can perform up to eight separate searches using any combination of criteria and text.

To access WatchWizard, press the **SEARCH** button on the remote control or **SELECT** the **WatchWizard** tab from the **MAIN MENU**. Define your searches using the **WATCHWIZARD SETUP** pane shown on page 27

Highlight and **SELECT** one of the eight search buttons..

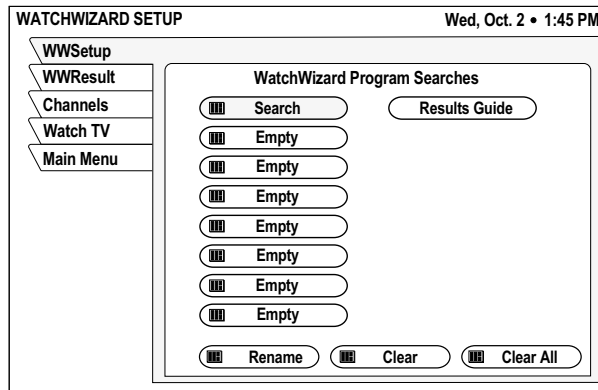

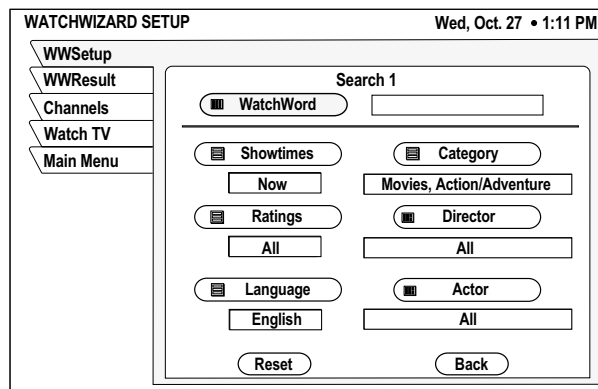

A search menu appears where you can enter your search criteria as shown below. Narrow your search results by combining criteria and text entries.



Highlight the **WWRResult** to see a list of programs matching your search criteria. **SELECT** the **Results Guide** menu button to view the search results as a guide. Pressing the **SEARCH** button on the remote control when any program guide is onscreen automatically highlights programs matching your search results. Pressing the **SEARCH** button again highlights the next result based on program starting time.

Use the on-screen keyboard to enter text (see figure on page 28). Press **SELECT** to enter the letter. Select **OK** when you are finished entering the desired text.

You can highlight and **SELECT** the toggle icon  on the default button board to change it to a standard keyboard layout if you desire. Highlight the desired letter using the  paddle or directional arrow buttons.

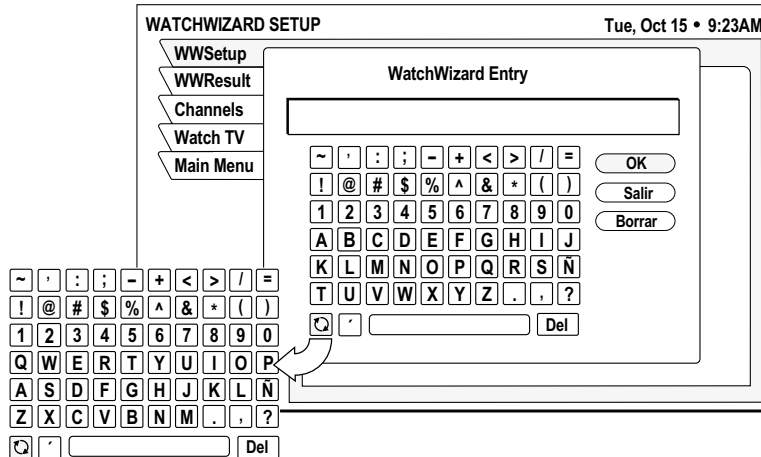

Using the Channels search You can also search for DIRECTV® channels showing a specific type of programming by using the category-based channel search.

Using the Program Director

You can program up to 32 events in advance for viewing or unattended recording by selecting **Program Director** from the **MAIN MENU**. The **PROGRAM DIRECTOR** menu allows you to automatically tune to a program at a specific date and time, or tune to a program on a repeating basis. You can:

- schedule programs for viewing (✓)
- schedule programs for taping () (*Model HAH-SA only*)
- specify programs to record by title (*Model HAH-SA only*)
- select **Cancel** from the menu if you decide not to schedule anything.

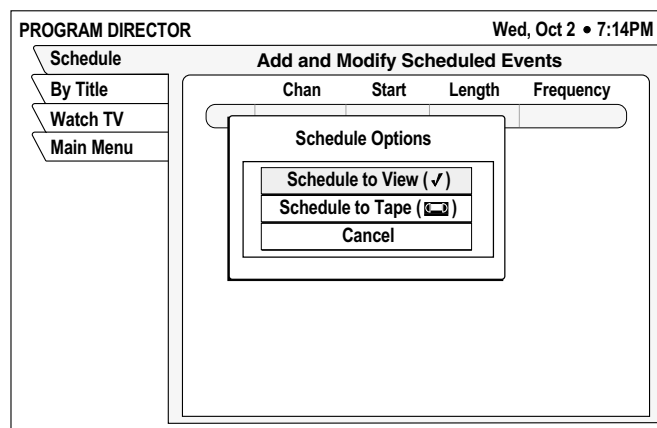

Scheduling or editing an event

There are three ways to schedule a program:

From the program guide:

1. Highlight an upcoming program in the program guide and press **SELECT**. A ✓ will appear next to your selection. Press **SELECT** again to cycle through the next available option (⏏ if available).
2. If you choose a scheduling option, the DIRECTV® Receiver will turn on (if necessary) and tune to the specified channel at the chosen date and time.
3. If you chose **Schedule to Tape** and you have set up your VCR (see page 8), the DIRECTV Receiver will record the event. For unattended recording:
 - Attach the VCR Control Cable and set up your VCR.
 - Set your VCR for the correct DIRECTV Receiver output: RF (channel 3/4) or A/V (phono or S-Video).
 - Insert a blank videotape and leave the VCR turned on.

You can schedule events up to eleven months in advance.

From the PROGRAM DIRECTOR menu Schedule tab:

1. Highlight an empty slot and press **SELECT**.
2. **SELECT** **Schedule to View** or **Schedule to Tape** from the **Schedule Options** menu.
3. Choose the desired channel from the channel selection pane. **SELECT OK**.
4. Use the ⏏ paddle or directional arrow buttons to specify AM or PM (or N for noon, or M for midnight if you specified 12:00).
5. Use the same procedure to set the program *Duration* in hours and minutes.
6. Use the ⏏ paddle or directional arrow buttons to advance to the *Frequency* column.
7. Specify when, or how often, the event occurs: *Today, Tomorrow, Every Mon, Every Tue, Every Wed, Every Thu, Every Fri, Every Sat, Every Sun, Everyday, Mon-Fri*, or *"/* (specify a date).
8. After setting the Frequency, use the paddle ⏏ or directional arrow buttons to advance.
9. Review your settings and choose **OK**, or choose **Cancel** to delete the edits.

If you specify a date, use the month/day format. The year is set automatically.

To record a program by entering a title:

1. Highlight the **By Title** tab under the **PROGRAM DIRECTOR** menu.
2. Highlight and **SELECT** one of the program selection menu buttons.
3. Use the on-screen keyboard to enter the name of the program you want to record.
4. **SELECT** the **OK** menu button when you are finished.

The receiver will tune to the next and subsequent broadcasts of the specified program and automatically record it.

The **Schedule** pane displays up to eight events at a time. If more than eight events are already scheduled, use the ⏏ paddle or directional arrow buttons to scroll down to view the additional events. Small arrows at the top or bottom of the list indicate that there are additional events.

To cancel a program scheduled for viewing or taping:

Find the upcoming program in the program guide you wish to cancel and press **SELECT** until the check mark (✓) or videotape icon (⏏) disappears. If the program is currently airing, you must delete the event from the **Schedule** menu pane accessed from the **PROGRAM DIRECTOR**.

Adjusting system settings

Select the **System** tab from the **MAIN MENU** to access the system functions described in this section. Use the **PREFERENCES** menu pane (shown in the figure below) to change the appearance of the on-screen menus and select how your DIRECTV® Receiver operates with other devices. The **PREFERENCES** pane also allows you to:

- Set the receiver output channel to channel 3 or 4
- Enable or disable the INPUT button on your remote control.
- Select English or Spanish language menus.
- Specify your time zone.
- Enable or disable daylight saving time
- Select full or short channel banner style
- Enable or disable Caller ID

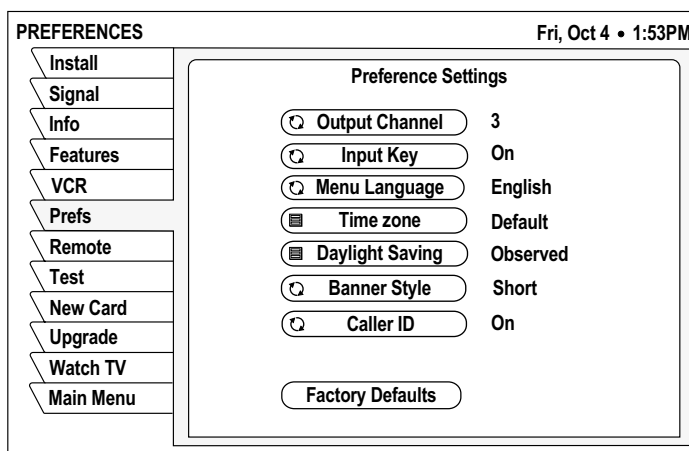

Set output channel Use the *Output Channel* menu button to toggle between channels 3 and 4, whichever is unused in your area.

Input key enable/disable The *Input Key* menu button allows you to turn the remote control INPUT button on and off.

Select menu language The *Menu Language* button allows you to display on-screen menus in English (default) or Spanish.

Caller ID enable/disable Use the *Caller ID* menu button to turn the Caller ID feature on and off. Incoming calls will not be displayed on-screen when the Caller ID feature is *disabled*.

Note: You must subscribe to Caller ID service from your telephone company to use this feature.

Restore factory default settings SELECT the *Factory Defaults* menu button to restore the **PREFERENCES** options to the original factory settings.

Antenna, Signal, and Test functions are described Chapter 1 – *Getting Started*.

Viewing Mail

DIRECTV uses the **MAIL** feature to send you important information, inform you of special events, and tell you about special offers. When you receive a new message, a *New Mail* icon appears at the top of all menus until you read the message. Highlight and **SELECT** the **View Mail** tab from the **MAIN MENU**.

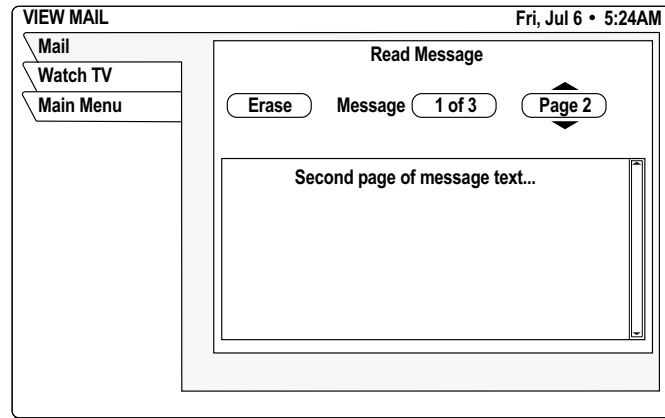

Message – **SELECT** the **Messages** button. Use the  paddle or directional arrow buttons to navigate through messages.

Page – Use the CHANNEL(CH) button to cycle through a multi-page message when the cursor is in the **Message** area.

Erase – Permanently remove a message. Messages are automatically deleted as they become outdated or if space is needed for newer incoming messages.

Using Caller ID

**You must subscribe to Caller ID from your local telephone company to use this feature.*

Your DIRECTV® Receiver shows you CID information when you receive an incoming call. The caller's name and telephone number appears in a banner across the lower portion of your screen while you're watching TV.

The **Call History** pane shows you the name, time, and telephone number of recent calls on your TV as shown in the figure below. To display the **Call History** pane, highlight and **SELECT** the **Caller ID** tab from the **MAIN MENU**.

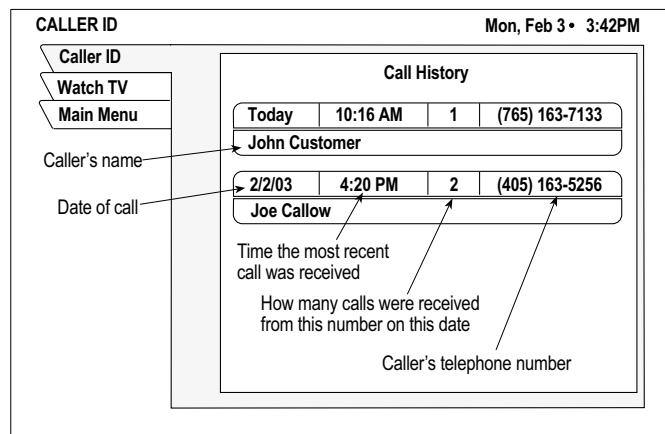

You can also highlight and **SELECT** a recent call from the **Call History** pane to dial the number shown on the screen.

This chapter explains:

- How to create a channel list (*this page*).
- Renaming a channel list (*see page 34*).
- Using *Auto Set*, *Add All*, and *Del All* functions (*see page 34*).
- How to filter the program guide (*see page 35*).
- How to change guide times (*see page 36*).

Using favorite channel lists

Channel Lists are provided to help you organize the hundreds of available channels into groupings suitable for your household. Each list can contain as many or as few channels as you wish. You can customize these groups several ways. For example, *Fav. A* could be Dad's favorite channels, *Fav. B* could be Mom's favorites, *Fav. C* could be the kids' channels, and *Family* could be all channels that Mom and Dad have deemed appropriate for the entire family.

Creating a channel list

1. Press the remote control MENU button.
2. Select the **Guide Options** or **Lock & Limits** from the **MAIN MENU**.
3. Use the  paddle or directional arrow buttons to highlight the **Fav Setup** tab.
4. Press SELECT to open the **FAVORITE LIST SETUP** pane shown below.

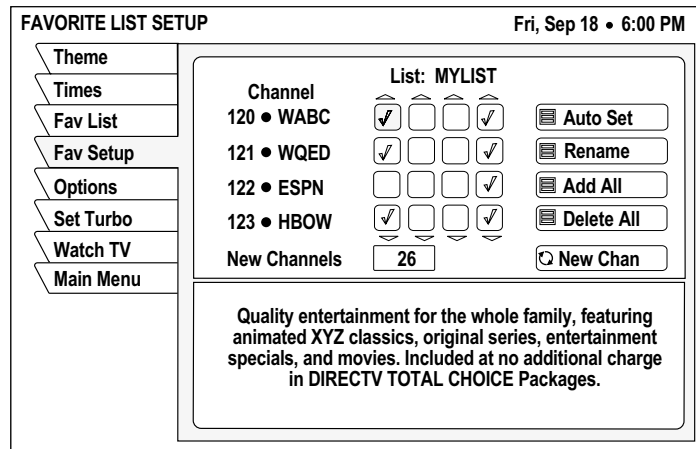

The four columns of small boxes on the right hand side of the pane are the *Tag Boxes*. The first three columns are the *Fav.A*, *Fav.B*, and *Fav.C* channel lists. The farthest right hand column is the *Family* list.

Note: If the *Family* list has not had channels added to it, no channels can be viewed without first unlocking the receiver. To avoid this inconvenience, create the *Family* list before locking the receiver. See Chapter 7 – *Using access controls*, on page 37 for additional details about controlling system access.

5. Use the  paddle or directional arrow buttons to highlight the tag box that corresponds to the channel number and list that you wish to create or change.
6. Press SELECT to add or remove the check mark, which indicates that the channel in that row is included in the list shown at the top of the column.

7. Scroll up or down to view channels and descriptions. Press **SELECT** to add channels to your list.
8. When you have added all of the channels you want to your list, use the  paddle or directional arrow buttons to highlight and **SELECT** the **Watch TV** tab to resume viewing.

Once you have created your lists, use the remote control **FAV** button to cycle through them quickly and easily. Each press cycles to next channel list. You can also select a list by highlighting the **Fav List** tab from the **Guide Options** menu..

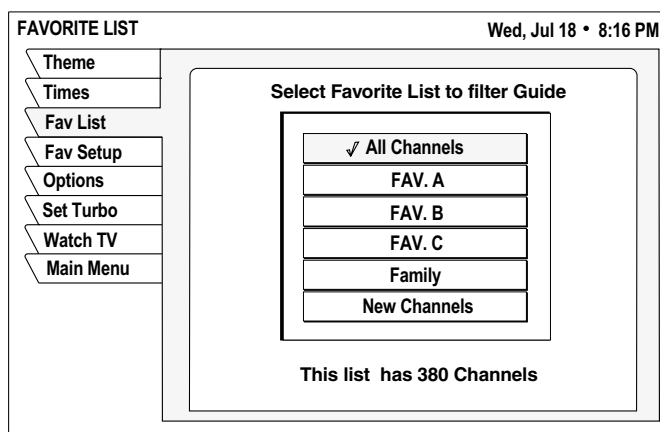

Renaming a channel list:

1. Highlight the **Rename** button and press **SELECT**.
A **Rename List** menu appears. You can rename the first three lists. You cannot rename the *All* and *Family* lists.
2. Highlight the list you wish to rename and press **SELECT**. A keyboard panel appears.
3. Highlight the desired letter using the  paddle or directional arrow buttons and press **SELECT**.
4. When finished, Select **OK**.

Creating an Auto Set list

1. **SELECT** the **Auto Set** button.
2. Highlight and **SELECT** a channel list to be programmed.
Once selected, the **Auto Set Progress** status panel appears. It may take several minutes for the receiver to scan through all of the channels and determine which ones you are authorized to receive. The results of this scan will be stored in the designated channel list.

Note: *Auto Set* may exclude some channels such as the Music Choice channels or include some pay per view channels. This does not mean that the receiver is faulty. These channels were excluded or included due to the DIRECTV® Receiver's analysis process. You can manually edit the lists to correct these oversights.

Adding and removing channels

Selecting the **Del All** menu button clears all channels from the list you have chosen. **Add All** has the opposite effect, creating a list of all the channels available on the DIRECTV® network.

To add or delete individual channels from your favorites lists, move the highlight to List boxes for the particular channel you wish to add or remove and

press **SELECT**. A checkmark (✓) appears in the box if the channel has been selected or the checkmark disappears to indicate the channel is not selected.

Finding new channels Occasionally, new channels are added to the available programming selections. The number of channels that have been added since you created your channel list appear in the *New Channels* window on the **FAVORITE LIST SETUP** pane. These channels appear in their own guide when you select *New Channels* in the **FAVORITE LIST** menu pane.

Filtering the program guide

Press the remote control **GUIDE** button while a program guide is onscreen or select the **GUIDE OPTIONS** tab from the **MAIN MENU** to display the **CATEGORY FILTER** menu. The menu provides filtering tools and ways to access other guide styles. By combining each of these filter options, you can quickly narrow down channels to those that match your viewing interests.

Using Theme Filters The **CATEGORY FILTER** menu allows you to filter the guide by program category groups.

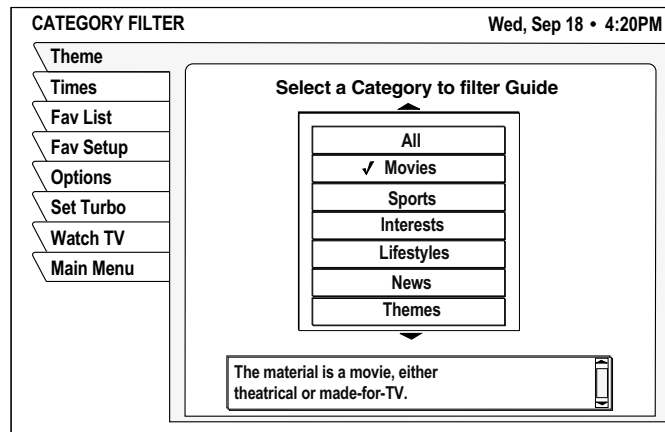

After choosing a category (other than *All*), the menu is replaced by the *Subcategory* menu panel. This menu allows you to further refine a chosen theme. In addition to *All*, you can select popular categories that can be quickly selected using the remote control **GUIDE** button.

For example, if you select the *Movies* category, you can then refine your selection using a subcategory such as *Action/Adventure*, *Animation*, *Biography*, *Comedy*, and others as shown in the figure on page 36.

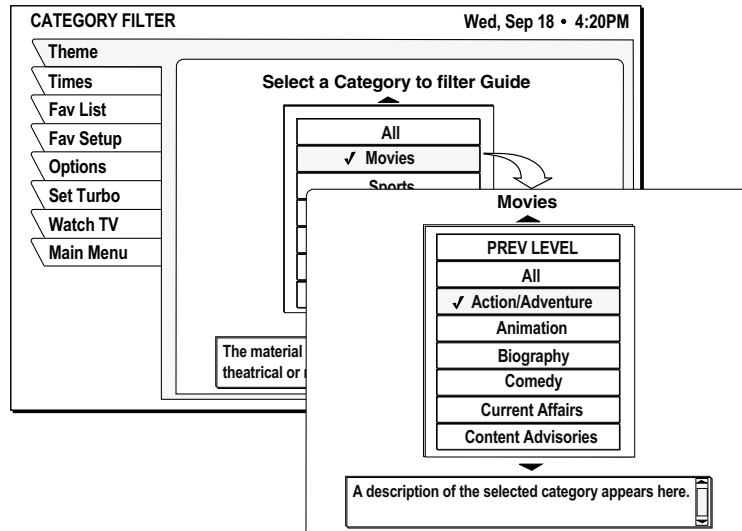

After selecting a subcategory, the guide will be further filtered to show only those channels offering programs of the selected category and subcategory. In this example, the guide would display channels featuring Action/Adventure movies.

Selecting guide times Highlight the **Times** menu tab. The **GUIDE TIMES** menu shown below provides easy access to future programming information. Simply select the day you want the guide to begin. Use the *AM/PM* menu button to select the proper time. The program guide showing the selected time will appear onscreen.

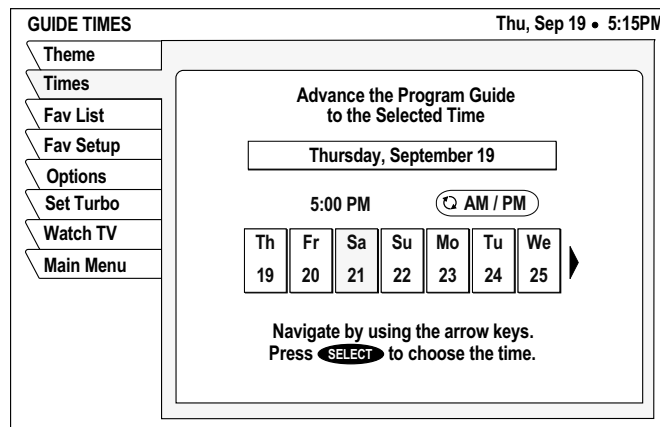

This chapter explains:

- How to lock and unlock the system.
- How to set maximum rating, spending, and time limits.

Locks & Limits provides settings to help you control the viewing restrictions of DIRECTV® programming. When accompanied by the channel lists, these limits provide a great degree of control. The DIRECTV® Receiver must be locked for the TV Timer, Rating and Spending limits to be enforced.

Locking & unlocking the system

When you first receive your satellite system, it will be unlocked; (i.e., no limits or restrictions are in effect). You must lock the system to enforce the limits (spending, ratings, TV timer, and “Family” favorite list).

Note: Once the DIRECTV Receiver is locked, only existing *Family* list channels will be accessible. If the *Family* list does not contain any channels, no channels can be viewed without first unlocking the receiver. To avoid this, verify the contents of the *Family* list before locking the receiver.

How to lock the system

When you SELECT the **Lock** button, the **LOCK SYSTEM** pop-up panel appears.

Press **Cancel** to clear the locking process.

1. Enter a four-digit passcode using the remote control then SELECT **OK**.
2. Enter the code again to confirm, then SELECT **OK**.

If you forget your four-digit code, you must call DIRECTV.

Once you select **OK**, the satellite receiver is locked. You must enter the passcode to unlock it. A lock symbol icon appears at the top of every menu screen to remind you that the system is locked.

Unlocking the system

To remove the lock and its restrictions:

1. Highlight the **Locks & Limits** tab from the **MAIN MENU**.
2. SELECT the **Unlock** menu button.
3. Enter the same code you entered to lock the system.

The button used to lock the system is also used to **unlock** the system.

Once the system is unlocked, **all limits and restrictions are removed!** Choose **Cancel** to keep the lock in effect.

Setting ratings limits

Program ratings help you determine if a program’s content is appropriate for a

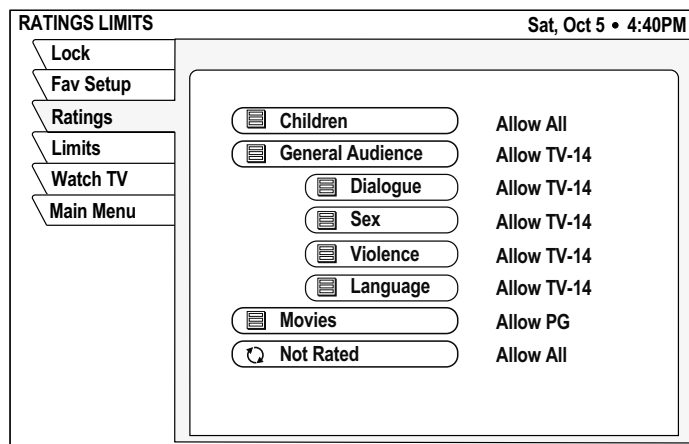

particular audience. To select the maximum ratings limits allowed to be viewed, highlight the **Ratings** tab, then **SELECT** the type programming you wish to restrict. For example, if you select the *Violence* menu button, a ratings pop-up submenu appears as shown in the figure below.

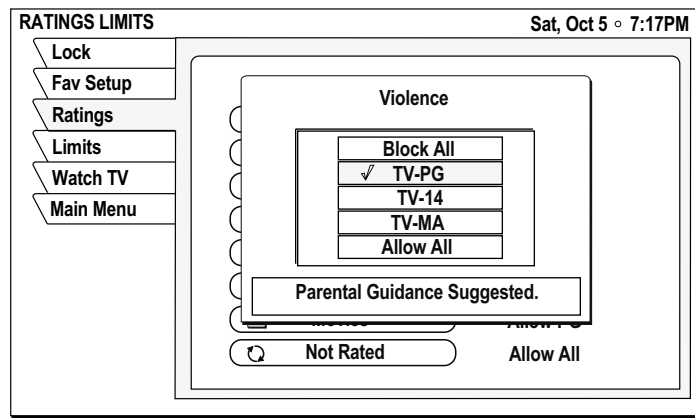

Highlight and **SELECT** the highest rating for violent program content you wish to allow. You may choose to *Block All* or *Allow All* instead of setting a specific limit.

Setting spending and time limits

Highlight the **Limits** tab to set the maximum spending limit. You can set the maximum purchase price on a per-event basis. To change the displayed limit:

1. Highlight the *Max Spending* button.
2. Press **SELECT** to display the **SPENDING LIMIT** pop-up panel.

Use this menu to set the specific hours and/or maximum hours the satellite receiver can be used for viewing.

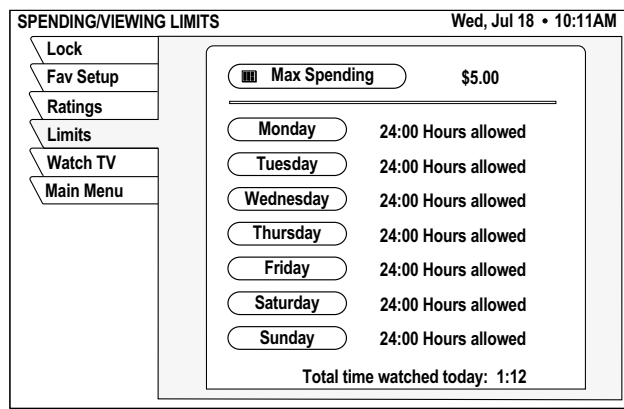

1. Use the number buttons on the remote control to set the limit or use the paddle to increase or decrease each digit.
2. Use the paddle to highlight the digit that you want to change.
3. Highlight *OK* and press **SELECT** to confirm the entered amount.

Questions? Did we forget to tell you something? We have compiled some of the most common questions and their answers here. We hope they help!

Q *I had a signal but now I am getting a message “Searching for satellite signal. To access related utilities, press SELECT.” What happened?*

A Rain clouds and snow can affect the satellite signal reception. This loss of signal is temporary. Also check for new growth on trees and bushes that could be blocking the signal. One other possibility is that the wind or someone has moved the satellite dish antenna.

Q *Why can't I control my TV?*

A Before you can control your TV, VCR, or any other device besides your satellite receiver, you must program your remote control to match your different devices. See Chapter 3 – *Using the remote control* in this manual for specific instructions. If you have already successfully programmed your remote control, try pressing the appropriate device key to put your remote in the proper mode. Then try controlling that device. Also, make sure that the batteries in the remote control are good.

Q *My satellite receiver does not respond when I press keys. What's wrong?*

A Most likely, if the front panel keys work but the remote control doesn't work, try pressing the SAT button before trying to control the digital satellite receiver. If that doesn't work, press the SAT and MUTE buttons together and try again. If that doesn't work, or if the front panel buttons don't work either, unplug your digital satellite receiver for 30 seconds, then plug it back in. Your satellite receiver is a computing device. It is susceptible to erratic changes in power and/or signal, just as any other computer, and these sudden changes can cause it to become “confused.”

Q *Some channels look good, while others freeze or indicate that no signal is available. What's wrong?*

A The most common causes for this behavior relate to an improperly grounded satellite cable. Check the cable between your digital satellite receiver and the satellite dish antenna. Confirm that RG-6 (not RG-59) cable is used and does not exceed 100 feet in length. Longer cable runs require amplification. This special amplifier is available from your dealer.

Q *I'm getting a message to call some extension. Why?*

A There are many different reasons for this. If you want to watch the channel that is displaying the message, call DIRECTV at 1-800-531-5000.

Q *Why don't I have an on-screen offer to purchase pay per view programs?*

A There are three possibilities; your digital satellite receiver must be connected to a phone line and it is not, or DIRECTV doesn't realize that your phone line is connected or has disabled your ability to make on-screen purchases. Call DIRECTV at 1-800-531-5000 for assistance.

Q Can I receive my local TV programs through my digital satellite receiver?

A There are three ways to receive local programming:

- If you are in an area where local programming is available via satellite and have the proper satellite dish antenna, contact DIRECTV to arrange for the necessary subscription package.
- Install a traditional antenna (i.e., roof mounted, attic mounted, rabbit ears).
- Arrange for basic or “lifeline” cable TV service from your local cable company.

If you select item 1 above, your local programming appears in the program guide like any other channel. For options 2 or 3, connect the local signal to the IN FROM ANTENNA jack on the back of your digital satellite receiver. Use the INPUT key to switch between DIRECTV® programming and local programming provided on the OUT TO TV connector.

Q I don't see Caller ID information appear on screen when I receive a telephone call. What could be wrong?

A There are several possible reasons. First, check that the satellite receiver is connected to an active telephone jack. Verify that the Caller ID feature is turned on (refer to page 30). Confirm that you subscribe to Caller ID service from your telephone company. Also check that your antenna is properly grounded as shown on page iv, as this can affect how the Caller ID feature works.

Q If I have questions about my satellite system or need to have it serviced, who should I call?

A For issues regarding your equipment, contact Hughes Consumer Care Center directly at 1-800-274-8995, or if you prefer, call your dealer first. They are most familiar with your installation and needs. Also, they are likely to be local to you.

If you need assistance with your subscription, such as adding channels, contact DIRECTV at 1-800-531-5000.

Q I think I set an event to record on my VCR, but when I played the tape back nothing was there. What could be wrong?

A There are several possible reasons for this. First, check that the VCR was programmed correctly and left turned on and the input matches the output from your digital satellite receiver. Confirm that you were authorized to tape the chosen program.

Q Why do I need to connect the satellite receiver to a telephone line?

A The telephone connection is used by the satellite receiver report purchase activity to DIRECTV.

Q I picked up my telephone and it was making a hissing and squealing sound. Why?

A Your digital satellite receiver was reporting any pay per view activity that may have occurred. This rarely happens and only lasts for a minute or so.

Q What if my question isn't listed here?

A Call your dealer or Hughes Consumer Care Center at 1-800-274-8995. We will do our very best to answer your questions.

Manufacturers device control codes



Use these codes to program your remote control to operate your components.

Table 3: VCR brands and remote control codes

BRAND	CODE NUMBER	BRAND	CODE NUMBER	BRAND	CODE NUMBER
Admiral	025 053	Garrard	034	Motorola	031 053
Adventura	034	GE	031 040 053 063 072 107 109 126 144 147 151 156	MTC	034 040
Aiko	117	GO Video	040 132 136	Multitech	024 034
Aiwa	034 101	Goldstar/LG	001 101 012 114 123	NEC	012 023 039 043 048
Akai	016 043 046 124 125 146	Harley Davidson	034	Nikko	101
American Action	117	Harman Kardon	012 045	Noblex	040
American High	031	Harwood	024	Nordmende	043
Ampro	072	Hitachi	001 026 034 063 137 150 156	Olympus	031
Anam	031	Hughes	001	Optimus	053 101
Asha	040	HQ	034	Optonica	053 054
Audio Dynamics	012 023 039 043	Instantreplay	031	Orion	025
Audiovox	101	JCL	031	Panasonic	031 066 070 133 160 161
Beaumark	040	JCPenney	001 012 031 040 066 101 156	Pentax	001 031 063 156
Broksonic	025 035 037 044 129 152	Jensen	043	Philco	025 031 034 067
Calix	101	JVC	048 050 043 130 060 012 031 150 055 158	Philips	031 034 054 067 071 101
Canon	028 031	KEC	101 117	Pilot	101
Capehart	108	Kenwood	014 023 034 047 048	Pioneer	001 021 048
CCE	024 117	KLH	024	Portland	108
Cineral	117	Kodak	031 101	Profitronic	040
Citizen	101 117	Lloyd	034	Protec	024
Colt	024	Logik	024	Quartz	002 014
Craig	003 024 101 040 135	LXI	034 003 009 017 101	Quasar	031 066 070 133 160 161
Curtis Mathes	031 041 156	Magin	040	Radio Shack	034 123
Cybernex	040	Magnasonic	117	Radix	101
Daewoo	005 007 010 065 108 110 112 116 117 119	Magnavox	067 031 034 041 064 068 154 160	Randex	101
Daytron	108	Marantz	012 023 031 067 069	RCA	001 031 034 040 041 053 107 109 140 144 147 151 156
DBX	012 023 039 043	Marta	101	Realistic	003 008 010 014 031 034 040 053 054 101
Dimensia	156	Matsui	027 030	Rico	058 078
Dynatech	034 053	Matsushita	031	Salora	014
Electrohome	059 101	MEI	031	Samsung	032 040 102 104 107 109 112 113 115 120 122 125 159
Electroponic	101	Memorex	003 010 014 025 031 034 040 053 072 101 102 134 139	Sanky	053
Emerson	006 017 025 027 029 031 034 035 036 037 044 046 101 117 129 131 138 152 153 157	MGA	045 046 059	Sansui	022 025 034 043 048 135
Fisher	003 008 009 010	MGN Technology	040	Sanyo	003 010 007 014 040 102 134
Fuji	031	Minolta	001 156	Scott	017 037 044 112 129 131 159
Funai	034	Mitsubishi	001 045 046 053 059 061 162		

Table 3: VCR brands and remote control codes

BRAND	CODE NUMBER	BRAND	CODE NUMBER	BRAND	CODE NUMBER
Sears	001 003 008 009 010 014 017 031 034 081 101	Tatung	023 039 043	Video Concepts	012 034 046
Sharp	031 054 053 143	Teac	023 034 039 043	Videosonic	040
Shintom	024	Technics	031 070	Wards	001 003 017 024 031 034 040 053 054 131
Shogun	040	Teknica	031 019 034 101	Westinghouse	024 025
Signature	034	Thomas	034	XR-1000	024 031 034
Singer	024	TMK	040	Yamaha	012 034 039 043
Sony	003 031 032 034 052 056 057 058 155	Toshiba	001 008 042 047 059 082 112 131	Zenith	025 034 048 056 058 072 080 101
Soundesign	034	Tatung	023 039 043		
STS	001	Teac	023 034 039 043		
Sylvania	031 034 059 067	Totevision	040 101		
Symphonic	034	Unitech	040		
Tandy	010 034	Vector	012		

Table 4: Television brands and remote control codes

BRAND	CODE NUMBER	BRAND	CODE NUMBER	BRAND	CODE NUMBER
Admiral	072 081 096 160 161	Classic	043	Goldstar/LG	004 106 110 112 119 127 143 193
Aiko	103	Concerto	004	Gradiente	004 038 106
Akai	070 146	Contec	043 050 051	Grunpy	028 043
Alaron	028	Coronado	143	Hall Mark	004
A Mark	112 143	Craig	043 054 191	Harley Davidson	028
America Action	043	Crosley	164	Harvard	043
Amstrad	052	Crown	043 143	Hitachi	004 007 009 010 011 012 023 072 075 143 158
Anam	043 054 056 080 112	Curtis	004 011 070 072 081 101 120 143 164	Harman	164
AOC	004 058 070 112	CXC	043	Infinity	164
Audiovox	043 076 103 120	Daewoo	004 016 043 044 076 103 114 120 127 128 136 143 192	Inteq	073
Baysonic	043	Daytron	004 143	JBL	164
Bell&Howell	072	Denon	011	JCB	001
Blaupunkt	088	Dumont	004 073	JCPenney	004 008 009 024 030 065 070 101 143 156 160
Bradford	043	Dynasty	043	Jensen	013
Brooksonic	096	Dynatech	062	JVC	001 034 038 083 199 208
Cairn	206	Electroband	001	KEC	043
Candle	002 003 004 070	Electrohome	024 076 120 143	Kenwood	001 070
Capehart	058	Emerson	004 005 028 043 047 048 050 051 070 076 096 120 143 151 153 154 155 191	Kloss	002 059
Carver	164	Fisher	007 057	KMC	143
CCE	001 004 024	Fujitsu	028 198 210 211	KTV	043 070 143 154
Celebrity	001	Funai	028 043 052	Lodgenet	072
Cetronic	043	Futuretech	043	Loewe	209 211
Cineral	103 120	GE	004 008 009 034 056 070 073 074 081 120 130 145 155 160 165 161 167	Logik	072
Citizen	002 003 004 043 070 101 103 143	Gibraltar	004 073	Luxman	004

Table 4: Television brands and remote control codes

BRAND	CODE NUMBER	BRAND	CODE NUMBER	BRAND	CODE NUMBER
LXI	007 015 052 081 160 164	Philips	164 093 038 005 059 127 070 003 004 213	SSS	004 043
Magnavox	003 004 022 059 060 061 063 064 070 094 127 160 164	Pioneer	025 070 004 018 023 190	Starlight	043
Majestic	072	Portland	004 143 065 103	Supre Macy	002
Marantz	070 164	Prism	034	Supreme	001
Matsui	164	Proscan	160 161 167 145 065	Sylvania	003 044 059 060 063 064 070 127 160 164
Matsushita	080	Proton	004 058 112 143 171 173	Symphonics	194 052
Megatron	-	Quasar	034 056 080 164	Tandy	081
Memorex	004 007 028 072 096	Radio Shack	004 019 043 127 143	Tatung	056 062
Metz	088	RCA	160 161 156 165 065 070 004 023 024 056 074 081 152 167 145	Technics	034 080
MGA	004 024 024 028 042 070	Realistic	007 019 043 047	Technol Ace	028
Midland	073	Runco	073 130	Techwood	004
Minerva	088	Sampo	004 070 058 207	Teknika	002 003 004 024 028 043 072 101 103 143 164
Minutz	008	Samsung	101 004 050 089 105 160 127 143 133 215	Telerent	072
Mitsubishi	004 024 028 040 042 081 146 214	Sansei	120	Tera	173
Motorola	081	Sansui	096	TMK	004
MTC	070 004 062 101	Sanyo	007 020 053 057 082	TNCI	073
Multitech	043	Scotch	004	Toshiba	015 030 007 040 062 101
NAD	015 025	Scott	004 028 043 048 143	Universal	008 009
NEC	004 016 019 024 040 056 070 130 134	Sears	004 007 015 028 030 052 057 082 094 143 160 164 167	Video Concepts	146
Nikei	043	Seleco	200	Vidikron	164
Nikko	103	Semivox	043	Vidtech	004
NTC	103	Semp	015	Wards	004 008 009 019 028 060 061 063 064 072 074 143 164 165
Onking	043	Sharp	004 014 019 022 028 081 143	Westinghouse	120 076
Onwa	043	Siemens	088	Yamaha	004 070
Optimus	080	Signature	072	York	004
Optonica	019 081	Sony	001 079 126	Yupiteru	043
Orion	028 096 201 202 203 204 205	Soundesign	003 004 028 043	Zenith	011 072 073 095 096 103
Panasonic	034 056 080 164 212	Spectricon	112	Zonda	112
Philco	003 004 024 056 059 060 063 064 070 164	Squareview	052		

Table 5: AUX audio brands and remote control codes

AUX	CODE NUMBER	AUX	CODE NUMBER	AUX	CODE NUMBER
Adcom	146 149 227 244	Bose	064 137 219	GE	123 216
AMC	083 084	B & K	150 152	Harmon	073 195 248 249
Arcam	100	Carver	013 098 107 126 129 160 163 220 245 249	Haitai	119
Audio File	093 098	Clarion	151 169	Hitachi	088
Audio Technica	221	Denon	101 133 191 202 208 246 247	JCPenney	109 154 178
Aiwa	111 114 117 156 170 199 203 219 231 241 254	Englightened Audio	078 153	Jensen	099
Akal	181 233	Fisher	107 129 157 163 176	Jerrold	141
Anam	180	Fosgate	228 248	JVC	112 198 252

Table 5: AUX audio brands and remote control codes

AUX	CODE NUMBER	AUX	CODE NUMBER	AUX	CODE NUMBER
Kenwood	096 104 119 125 148 151 163 171 173 242	Niles	236	Scott	180 190
Krell	223	Onkyo	094 115 116 209 211 255	Sharp	096 125 151 161 169 182 193
Lexicon	215 250	Optimus	121 125 140 181	Sherwood	089 127
Luxman	066 120 205 229	Panasonic	131 144 187 200	Sony	097 117 147 183 188 192 200 237 238 253
LXI	123 177	Parasound	085 086 090	Soundstrea	197
Magnavox	126 162 185 186 224 228	Philips	126 136 186 197	Starcom	141
Marantz	074 105 126 128 139 155 162 186 232	Pioneer	081 093 138 165 189 195 230 243	Symphonic	124
McIntosh	251	Quasar	131 187	Teac	062 102 159 180
Mondial	069 225	RCA	109 166 213	Technics	131 165 184 187 200 202 208
MCS	178	Realistic	103 122 123 124 172 174 177 179 180	Toshiba	175
Mitsubishi	253	Rotel	204 218 239	Wards	163
Meridian	013 067	Sansui	075 126 139 196 197 214	Yamaha	092 120 125 166 169 216 240
NAD	128	Sanyo	129 157	Zenith	061 222
Nakamichi	072 212 234 235	Samsung	068		

Table 6: AUX-CATV brands and remote control codes

CATV	CODE NUMBER	CATV	CODE NUMBER	CATV	CODE NUMBER
Hamlin	015 017 022	Pioneer	007 026 027	Zenith	004
Jerrold/G.I	010 021 025	Scientific Atlanta	002 006 013		
Oak	008 016 023	TOCOM	003		

Table 7: DVD player brands and remote control codes

BRAND	CODE NUMBERS	BRAND	CODE NUMBERS	BRAND	CODE NUMBERS
Alpine	009	Kenwood	070	Proscan	035 036
Apex Digital	075 076	Magnavox	008 038 042	RCA	035 036
Arcam	065	Marantz	006 007	Samsung	029 040 095
Cyberhome	087	McIntosh	071	Sharp	004
Daewoo	087	Mitsubishi	032	Sony	037 080
Denon	030 226	NAD	077	Technics	003
GE	035 036	Onkyo	207	Theta Digital	034
Goldstar/ LG	028 041	Optimus	034	Toshiba	001 038 082 091 206
Harmon Kardon	217	Panasonic	003 039	Yamaha	039 079
Hitachi	011	Philips	006 007 038 042 063	Zenith	028 041
Hiteker	076	Pioneer	005 010 034		
JVC	031	Proceed	002		

Table 8: DVD-Laser Disc Player brands and remote control codes

BRAND	CODE NUMBER	BRAND	CODE NUMBER	BRAND	CODE NUMBER
California Audio	047	NAD	057	Sanyo	052
Denon	043 044	Panasonic	047 051 054	Sharp	060
Fisher	047	Philips	048	Sony	050 053
Kenwood	060	Pioneer	055 057	Technics	047 051 054
Magnavox	048 057	Quasar	047	Toshiba	060
Mitsubishi	057	RCA	046	Yamaha	045 059

A

- A/V receiver, connecting 9
- Advance select 28
- Aligning the antenna 4
- Alternate audio 25
- Antenna
 - alignment values 4
 - cable, connecting 2
 - pointing 4
 - terrestrial 7
- Audio
 - balance 25
- AUX audio brands and control codes 43
- Azimuth angle, determining 4

B

- Batteries, installing 15

C

- Caller ID service 31
- Caller ID, disable 30
- Can't Tape message 9
- Cancel purchase 24
- CATV brands and remote control codes 44
- Changing menu language 30
- Channel banner
 - location 19
 - removing from screen 19
- CLEAR button 13
- Codes, device control 41
- Controls
 - device 14, 41
 - front panel 4
 - VCR, testing 8

D

- Default audio 25
- Delete event, preselected 29
- Device control codes 41
- DIRECTOR buttons 13
- Dish antenna pointing 4
- Dolby
 - digital connection 9
 - Pro Logic 9
- DVD player remote control codes 44

E

- Edit preselected program 29
- Elevation angle, determining 4
- English language menus 30
- Entertainment system, connecting 9

F

- Factory settings, restore 30
- Front panel controls 4

G

- Guide
 - features 19
 - grid style 17
 - logo style 18
 - selecting style 17
 - styles 17
- GUIDE button 13

H

- History, purchase 24

I

- Icons
 - interactive features 21
 - menu 24
 - multiple box 24
 - new mail 31
 - on-screen display 24
 - option list 24
 - taping 28
 - toggle 24
 - viewing 28

- ID, receiver 15
- Info Banner, using 19
- INFO button 13
- INPUT button 13
- Input key enable 30

J

- Joystick
 - functions 11, 12
 - icon 13

L

- Language, menu 30
- Locate satellite 4

M

- Mail
 - Erase 31
 - message 31
 - viewing 31
- Menu
 - features 19
 - function overview 23
 - icons 24
 - language 30
 - tabs 19

- Multiple box icon 24

N

- New mail icon 31

O

- On-screen menu language 30
- Options list icon 24
- Ordering events via phone 24
- Output channel, setting 30

P

- Past purchases pane 24
- Pay per view
 - history 24
 - purchase 24
 - upcoming events 25
- Phone jack connection 3
- Picture-In-Guide
 - options 17
- Preferences, system 30
- Program guide
 - features 19
 - styles 17
- Purchase Pay Per View event 24

- Purchases not listed 24

R

- Rear panel
 - connections 2
 - phone jack connector 3
- Recording
 - unattended 28
 - VCR setup 29
- Remote control
 - batteries 15
 - changing ID 15
 - manufacturers device codes 41
 - models 11
 - programming 14
 - quick reference 11, 12
 - sensor, VCR 8
 - TV codes 42
- Replacing batteries 15
- Restore factory settings 30

S

- SAT button 13
- Scanning remote control codes 11
- Schedule programs 28
- Search for words 27
- Signal indication 5
- Spanish language menus 30
- Surround sound, Dolby 9
- S-Video connection 3
- System menu functions 30
- System Setup screen 4

T

- Tags, menu 19
- Tag boxes 33
- Telephone connection 3
- Testing
 - results 5, 6
 - satellite signal 5
- Transponder
 - signal strength 5
 - testing 5
- TurboTune, assigning channels 20
- TV connection types 3
- TV remote control codes 42

U

- Unattended recording 29
- Unviewed purchases 24
- Upcoming purchases menu 25

V

- VCR
 - Brands 41
 - connecting 7
 - control cable 8
 - control codes 41
 - remote control sensor 8
 - testing 8

W

- WatchWord entries 27

Z

- ZIP code antenna alignment 4

Limited Warranty

Hughes Network Systems (HNS) provides the following limited equipment warranty on this equipment.

This limited warranty is in lieu of all other warranties, whether express, implied, or statutory, including, without limitation, the implied warranties of merchantability and fitness for a particular purpose. HNS shall not be liable for damages in excess of the purchase price of the product less reasonable amount for use and wear, or for any incidental, special, punitive, or consequential damages of any nature whatsoever, or for any delays, loss of use, time, profits, revenue or savings, any commercial loss, inconvenience, damage to buyer's or to other person's property, arising from the use or inability to use the product, or otherwise for any failure to perform.

HNS neither assumes nor authorizes any customer care center or any other person or entity to assume any other obligation or liability beyond that which is provided for in this limited warranty. No oral or written information or advice given by HNS, its dealers, distributors, agents or employees, shall create a warranty or in any way increase the scope of this warranty.

Some states do not allow the exclusion or limitation of incidental or consequential damages, or limitations of implied warranties, so the above limitations or exclusions may not apply to Purchaser.

This Limited Warranty gives specific legal rights to Purchaser, and Purchaser also may have other rights which may vary from state to state.

Provisions

Your Hughes manufactured DIRECTV® Receiver, Satellite dish Antenna, and Remote Control are warranted against defects in materials and workmanship for parts and labor.

Part	HAH-SA Satellite Receiver	HBH-SA, SD-HBH Satellite Receiver	HRMC-11, HRMC-12, HRMC-13 Remote Control	HANT-XX Dish and LNB(s)
Warranty Period	1 year parts, 90 days labor	1 year parts, 90 days labor	90 days parts	1 year parts

This limited warranty does not cover:

- a unit that has been modified
- damage from misuse, negligence, or accident
- any installation, or damages caused by installation
- shipments to HNS that are damaged in transit
- removal and reinstallation of equipment for repair
- loss of programming
- cost of shipping to HNS
- batteries or cables after installation
- acts of God

This limited warranty is not transferable and is valid only in the United States.

Service

If you have any questions or encounter any problems, you may contact your authorized HNS dealer or call our Customer Care Center, at 1-800-274-8995. To ensure prompt and efficient service, please have your

model and serial numbers handy. Space to note these numbers is provided inside the front cover of this manual. In the event of repair or replacement, you will need these numbers, along with your bill of sale.

Return Procedures

If your equipment requires repair or replacement, you can:

- contact your authorized HNS dealer or call our Customer Care Center to find the authorized service center nearest you.

OR

- choose the "replace after receipt" option, whereby you must ship HNS your defective equipment and, once your unit is received, a new or refurbished unit (at the sole discretion of HNS) will be shipped to you.

Packing Instructions for Equipment to be Returned

1. Call the Customer Care Center. The Customer Care technician will give you an RMA (Return Merchandise Authorization) and a mailing address for returning your unit.
2. If you are returning the digital satellite receiver, **please keep your access card and return only the digital satellite receiver.**
3. Pack the unit in the original box and packing material, if possible, or in other packaging that provides adequate protection for shipping. Include your name and address, the model number, the serial number, and a copy of the bill of sale.
4. Write: "**Attention: RMA #**" (the number given to you by the Customer Care technician) on the return shipping label.
5. Insure the shipment for the full replacement value.

HUGHES WARRANTY REGISTRATION FORM

HUGHES WARRANTY REGISTRATION

A Few Minutes of Your Time Can Help Shape Our Next Generation of Products

You may REGISTER ONLINE at: **www.hns-usa.com/warranty**

or complete this form and mail it.

Name _____

Address _____

City, State, ZIP _____

Phone (Day) _____ Phone (Evening) _____

E-mail Address _____

Receiver Unit Serial Number (Located on back of receiver) _____

Place of Purchase _____

City/State _____

Date of Purchase _____ Date of Installation _____

WHAT FACTORS WERE MOST IMPORTANT IN YOUR DECISION TO PURCHASE A HUGHES DIRECTV SYSTEM? Please rank the 4 most important factors from 1 to 4 (1 being the most important):

___ Quality ___ Price ___ Features
___ Warranty ___ Ease of use ___ Options
___ Other (please specify) _____

WHAT OTHER BRANDS DID YOU CONSIDER? (Check all that apply).

RCA Zenith
 Samsung Phillips
 Dish Panasonic
 Sony Other

WHICH DIRECTV® SYSTEM DID YOU PURCHASE?

Place a check (✓) for your system. Check all that apply.

SD-HBH/18
Basic Satellite Receiver 90 days labor, 1 year parts

HBH-SA/18
Director Pack™ 90 days labor, 1 year parts

HAH-SA/18
Executive Director Pack™ 90 days labor, 1 year parts

_____ (Please enter the last two (2) digits of the model number)

Upon receipt of this coupon, HUGHES will enter your information into our customer response database for fast, accurate service. If you have any questions about your warranty, please call 1-800-274-8995.

EXCLUDING YOUR DIRECTV SYSTEM, WHAT WERE THE LAST TWO HOME ELECTRONICS ITEMS YOU PURCHASED?

1. _____ 2. _____

Do you have a PC at Home? Y N ...AOL at Home? Y N ...a Home Office? Y N

ARE YOU INTERESTED IN MORE INFORMATION ON OUR DIRECWAY® BROADBAND INTERNET SERVICES FOR THE HOME OR OFFICE?

Yes, please send me more information on DIRECWAY for my home. Yes, please have a sales representative call me about more information on DIRECWAY for my office.

Mailing Instructions:

- Complete the above registration form
- Tear off back page of manual
- Fold completed registration page and place in an envelope
- Place stamp on envelope and mail registration to:

Hughes Network Systems
11717 Exploration Lane
Germantown, MD. 20876-9972
Attn: Sales Support & Services

