



FLG4 SIPHON & PRESSURE FEED SPRAY GUNS
MODELS: FLG-CNS-115, FLG-HVS-322, & FLG-HVP-315



FLG-HVP-315 HVLP
Pressure Feed



FLG-CNS-115
Conventional
Siphon Feed w/Cup

FLG-HVS-322
HVLP Siphon Feed
w/Cup

GUN DESCRIPTION

The FinishLine™ series are general purpose spray guns for both conventional and HVLP spraying applications suitable for use with a wide variety of common coating materials. Models FLG-HVP-315 and FLG-HVS-322 are HVLP spray guns, and model FLG-CNS-115 is conventional.

SPECIFICATIONS

| | |
|-------------------------|---------------------------------------|
| Maximum Air Pressure: | 100 psi |
| Maximum Fluid Pressure: | 100 psi |
| Gun Body: | Forged Aluminum |
| Fluid Path: | Anodized Aluminum and Stainless Steel |
| Fluid Inlet: | 3/8" NPS male |
| Air Inlet: | 1/4" NPS male |
| Gun Weight | |
| Pressure Feed: | 19.43 oz / 551 g |
| Siphon Feed w/cup: | 26.73 oz / 758 g |

IMPORTANT! DO NOT DESTROY

It is the Customer's responsibility to have all operators and service personnel read and understand this manual. Contact your local DeVilbiss representative for additional copies of this manual.

READ ALL INSTRUCTIONS BEFORE OPERATING THIS DEVILBISS PRODUCT.

SAFETY PRECAUTIONS

This manual contains information that is important for you to know and understand. This information relates to USER SAFETY and PREVENTING EQUIPMENT PROBLEMS. To help you recognize this information, we use the following symbols. Please pay particular attention to these sections.

WARNING

Important safety information – A hazard that may cause serious injury or loss of life.

CAUTION





Important information that tells how to prevent damage to equipment, or how to avoid a situation that may cause minor injury.

NOTE

Information that you should pay special attention to.

WARNING

The following hazards may occur during the normal use of this equipment. Please read the following chart before using this equipment.

| HAZARD | CAUSE | SAFEGUARDS |
|--|---|---|
| Fire  | Solvent and coatings can be highly flammable or combustible especially when sprayed. | Adequate exhaust must be provided to keep air free of accumulations of flammable vapors. Smoking must never be allowed in the spray area. Fire extinguishing equipment must be present in the spray area. |
| Solvent Spray  | During use and while cleaning and flushing, solvents can be forcefully expelled from fluid and air passages. Some solvents can cause eye injury. | Wear eye protection. |
| Inhaling Toxic Substances  | Certain materials may be harmful if inhaled, or if there is contact with the skin. | Follow the requirements of the Safety Data Sheet supplied by your coating material manufacturer. Adequate exhaust must be provided to keep the air free of accumulations of toxic materials. Use a mask or respirator whenever there is a chance of inhaling sprayed materials. The mask must be compatible with the material being sprayed and its concentration. Equipment must be as prescribed by an industrial hygienist or safety expert, and be NIOSH approved. |
| Explosion Hazard - Incompatible Materials  | Halogenated hydrocarbon solvents - for example; methylene chloride and 1,1,1 - Trichloroethane are not chemically compatible with the aluminum that might be used in many system components. The chemical reaction caused by these solvents reacting with aluminum can become violent and lead to an equipment explosion. | Guns with stainless steel internal passageways may be used with these solvents. However, aluminum is widely used in other spray application equipment - such as material pumps, regulators, valves, and this gun and cup. Check all equipment items before use and make sure they can also be used safely with these solvents. Read the label or data sheet for the material you intend to spray. If in doubt as to whether or not a coating or cleaning material is compatible, contact your material supplier. |
| General Safety | Improper operation or maintenance of equipment. | Operators should be given adequate training in the safe use and maintenance of the equipment (in accordance with the requirements of NFPA-33, Chapter 15). Users must comply with all local and national codes of practice and insurance company requirements governing ventilation, fire precautions, operation, maintenance, and housekeeping. These are OSHA Sections 1910.94 and 1910.107 and NFPA-33. |
| Cumulative Trauma Disorders ("CTD's") CTD's, or musculoskeletal disorders, involve damage to the hands, wrists, elbows, shoulders, neck, and back. Carpal tunnel syndrome and tendonitis (such as tennis elbow or rotator cuff syndrome) are examples of CTD's. | Use of hand tools may cause cumulative trauma disorders ("CTD's"). CTD's, when using hand tools, tend to affect the upper extremities. Factors which may increase the risk of developing a CTD include: 1. High frequency of the activity. 2. Excessive force, such as gripping, pinching, or pressing with the hands and fingers. 3. Extreme or awkward finger, wrist, or arm positions. 4. Excessive duration of the activity. 5. Tool vibration. 6. Repeated pressure on a body part. 7. Working in cold temperatures. CTD's can also be caused by such activities as sewing, golf, tennis, and bowling, to name a few. | Pain, tingling, or numbness in the shoulder, forearm, wrist, hands, or fingers, especially during the night, may be early symptoms of a CTD. Do not ignore them. Should you experience any such symptoms, see a physician immediately. Other early symptoms may include vague discomfort in the hand, loss of manual dexterity, and nonspecific pain in the arm. Ignoring early symptoms and continued repetitive use of the arm, wrist, and hand can lead to serious disability. Risk is reduced by avoiding or lessening factors 1-7. |

FLG4 SIPHON / PRESSURE FEED SPRAY GUNS AND DeKUPS® DISPOSABLE CUP SYSTEM

IMPORTANT: Before using this equipment, read all safety precautions on page 2 and instructions. Keep for future use.

WARNING

Halogenated hydrocarbon solvents - for example; 1, 1, 1-trichloroethane and methylene chloride - can chemically react with the aluminum in this gun and cause an explosion hazard. Read the label or data sheet for the material you intend to spray. Do not use spray materials containing these solvents with this spray gun.

IMPORTANT: This gun may be used with most common coating and finishing materials. It is designed for use with mildly corrosive and non-abrasive materials. If used with other high corrosive or abrasive materials, it must be expected that frequent and thorough cleaning will be required and the necessity for replacement of parts will be increased.

OPERATION

Strain material thru 60 or 90 mesh screen.

Model FLG-CNS-115:

The No. 1 (conventional) air cap requires an air supply at the gun inlet of approximately 45 psi, measured with the trigger pulled and can be operated from a 3 H.P. compressor.

HVLP Models FLG-HVS-322 and FLG-HVP-315:

The No. 3 (HVLP) air cap requires an air supply at the gun inlet of 23 psi max., measured with the trigger pulled.

This gun was manufactured to provide maximum transfer efficiency by limiting air cap pressure to 10 psi (complies with rules issued by SCAQMD and other air quality authorities).

This gun will produce approximately 10 psi cap pressure at 23 psi inlet pressure, as measured at the gun inlet. An air cap test kit (see ACCESSORIES) should be used to ensure 10 psi cap pressure is not exceeded.

Adjust fluid pressure to deliver the desired paint volume. Adjust air pressure and fluid flow to provide a uniform dispersion of atomized paint throughout the pattern. Keep air pressure as low as possible to minimize bounce - back and overspray. Excessive air pressure will result in split patterns. Low air pressure will result in heavy centered patterns and poor atomization. Excessive fluid flow will result in heavy center spray patterns. Inadequate fluid flows may cause the pattern to split. See "TROUBLESHOOTING" section.

PREVENTIVE MAINTENANCE

To clean air cap and fluid tip, brush exterior with a stiff bristle brush. If necessary to clean cap holes, use a broom straw or toothpick if possible. If a wire or hard instrument is used, extreme care must be used to prevent scratching or burring of the holes which will cause a distorted spray pattern.

To clean fluid passages, remove excess material at source, then flush with a suitable solvent. Wipe gun exterior with a solvent dampened cloth. Never completely immerse in solvent as this is detrimental to the lubricants and packings.

Note

When replacing the fluid tip or fluid needle, replace both at the same time. Using worn parts can cause fluid leakage.

CAUTION

To prevent damage to the fluid tip (2) or fluid needle (7), be sure to either:

- Pull the trigger and hold while tightening or loosening the fluid tip, or
- Remove fluid needle adjusting knob (6) to relieve spring pressure against needle collar.

Spray Gun Lubrication

Daily, apply a drop of SSL-10 spray gun lube at trigger bearing stud and the stem of the air valve. The shank of the fluid needle where it enters the packing nut should also be oiled. The fluid needle packing (7) should be kept soft and pliable by periodic lubrication. Make sure the baffle (4) and retaining ring (1) threads are clean and free of foreign matter. Before assembling retaining ring to baffle, clean the threads thoroughly, then add two drops of SSL-10 spray gun lube to threads. The fluid needle spring (6) and air valve spring (8) should be coated with a very light grease, making sure that any excess grease will not clog the air passages. For best results, lubricate daily.

FLG4 SIPHON / PRESSURE FEED SPRAY GUNS AND DeKUPS® DISPOSABLE CUP SYSTEM
Chart 1 – FLG4 HVLP and Conventional Models, Siphon / Pressure

| Spray Gun Model Number | Application Type | Number on Air Cap | Air Cap Kit (Ref. No. 1) | Fluid Tip (Ref. No. 2) | Fluid Tip Size Supplied With Gun |
|------------------------|----------------------------------|-------------------|--------------------------|------------------------|----------------------------------|
| FLG-HVP-315 | Pressure – HVLP | 3 | FLG4-1-3-K | FLG-332-15K | 1.5 mm |
| FLG-HVS-322 | Siphon/Pressure – HVLP | 3 | FLG4-1-3-K | FLG-332-22K | 2.2 mm |
| FLG-CNS-115 | Siphon / Pressure – Conventional | 1 | FLG4-1-1-K | FLG-332-15K | 1.5 mm |

Chart 2 – Fluid Tips

| Fluid Tip & Seal (Ref. No. 2) Part No. | Fluid Tip Size (in.) | Fluid Tip Size (mm) | Applications |
|--|----------------------|---------------------|--|
| FLG-332-13K | 0.051 | 1.3 | Stains, lacquers, basecoats, clears. |
| FLG-332-15K | 0.059 | 1.5 | General purpose, light to medium viscosity material. |
| FLG-332-18K | 0.070 | 1.8 | Medium viscosity materials. |
| FLG-332-22K | 0.086 | 2.2 | Heavy viscosity materials. |

Chart 3 – HVLP Air Flows (#3 Cap)

| Inlet Pressure (PSI) | Air Flow (SCFM) | Cap Pressure (PSI) |
|----------------------|-----------------|--------------------|
| 15 | 10 | 6 |
| 19 | 11.5 | 8 |
| 23 | 13.5 | 10 |

DeKUPS® — HOW TO USE THE SYSTEM

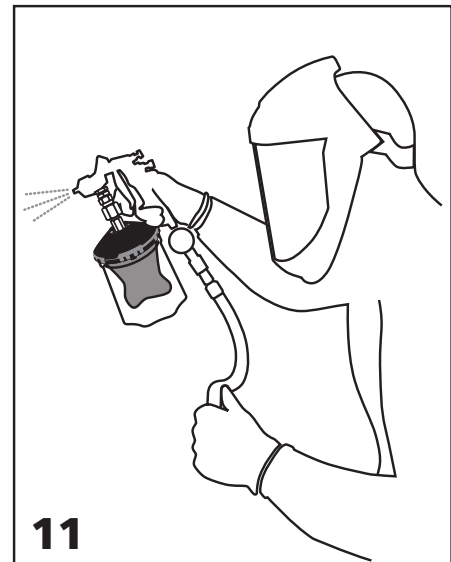
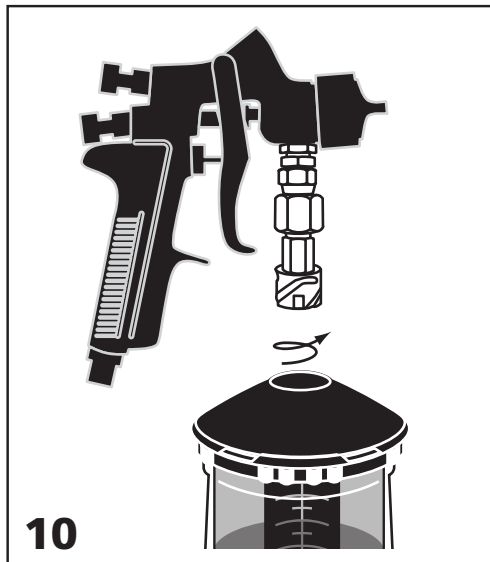
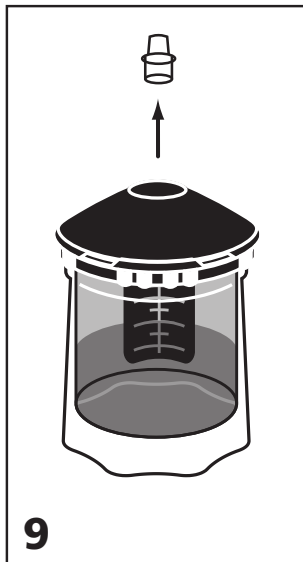
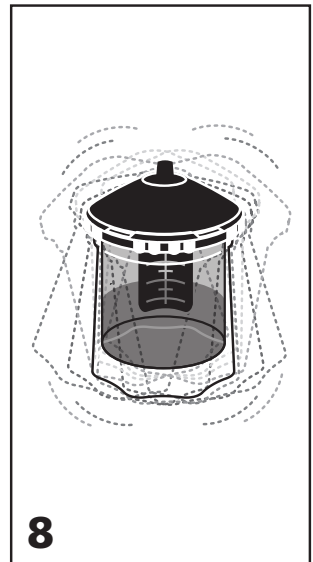
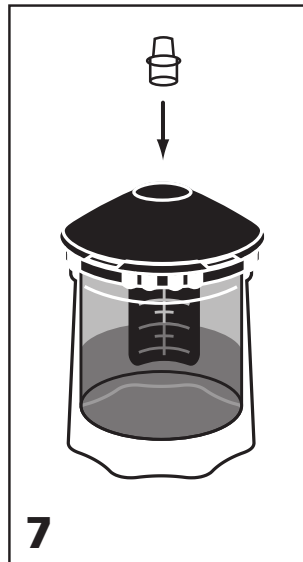
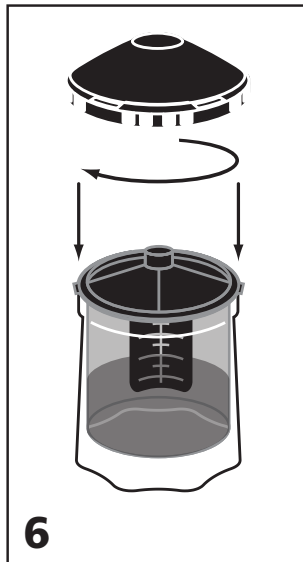
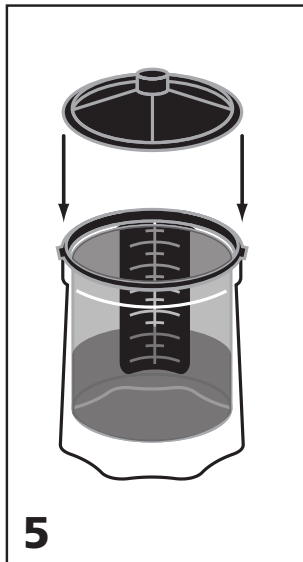
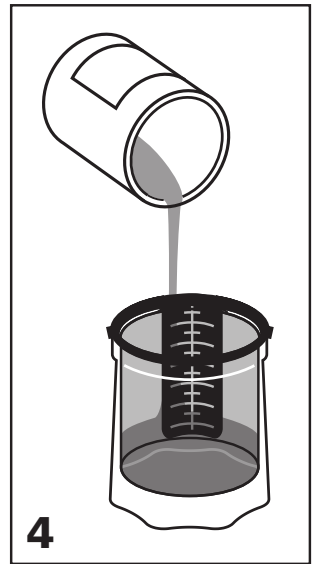
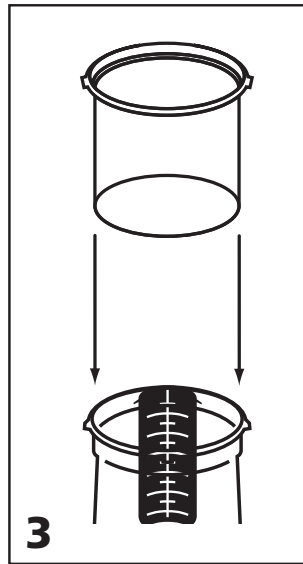
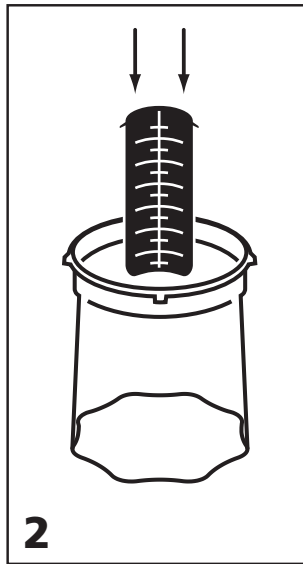
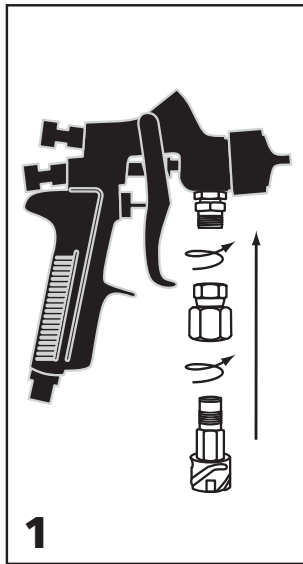

Gun Drawing

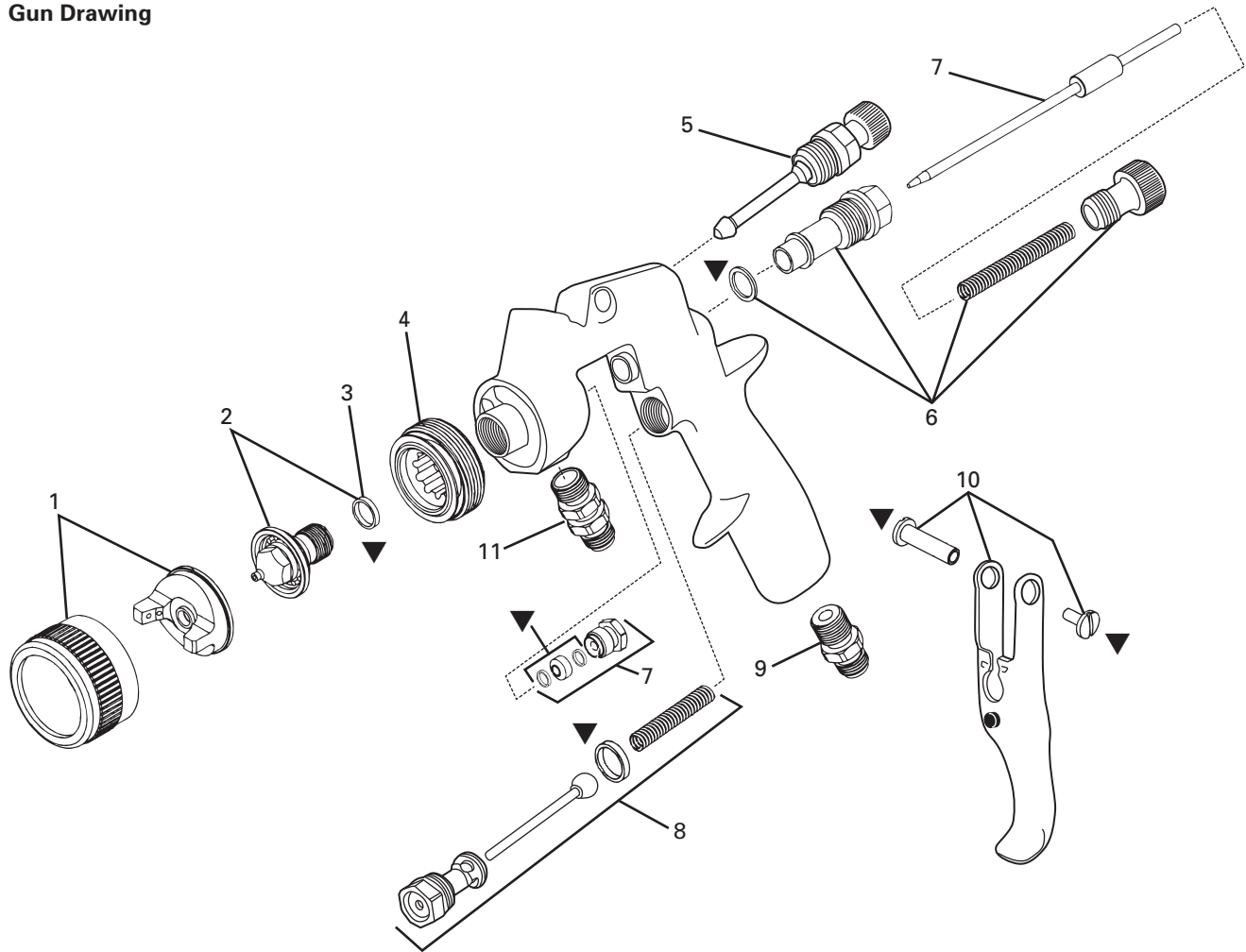

PARTS LIST

| Ref. No. | Replacement Part No. | Description | Ind. Parts Required |
|----------|----------------------|---|---------------------|
| 1 | See Chart 1, p.4 | Air Cap & Ring Kit | 1 |
| 2 | See Chart 2, p.4 | Fluid Tip & Seal Kit | 1 |
| 3 | FLG-304-K5 | Fluid Tip Seal (Kit of 5) | 1 |
| 4 | FLG-305 | Baffle | 1 |
| 5 | FLG-465 | Spreader Air Adjustment Valve | 1 |
| 6 | FLG4-364-K | Needle Knob, Spring, Bushing & Gasket Kit | 1 |
| 7 | FLG4-366-K | FLG4 Needle, Needle Packing & Nut Kit | 1 |
| 8 | FLG4-468-K | Air Valve & Gasket Kit | 1 |
| 9 | P-MB-51 | Air Inlet Nipple | 1 |
| 10 | FLG4-108-K | Trigger, Trigger Stud & Screw | 1 |
| 11 | JGA-4044 | Fluid Inlet & Nut Kit | 1 |

FLG-463 Air Cap #3 HVLP Test Cap

JGA-4035-K5 Needle Packing (Kit of 5)



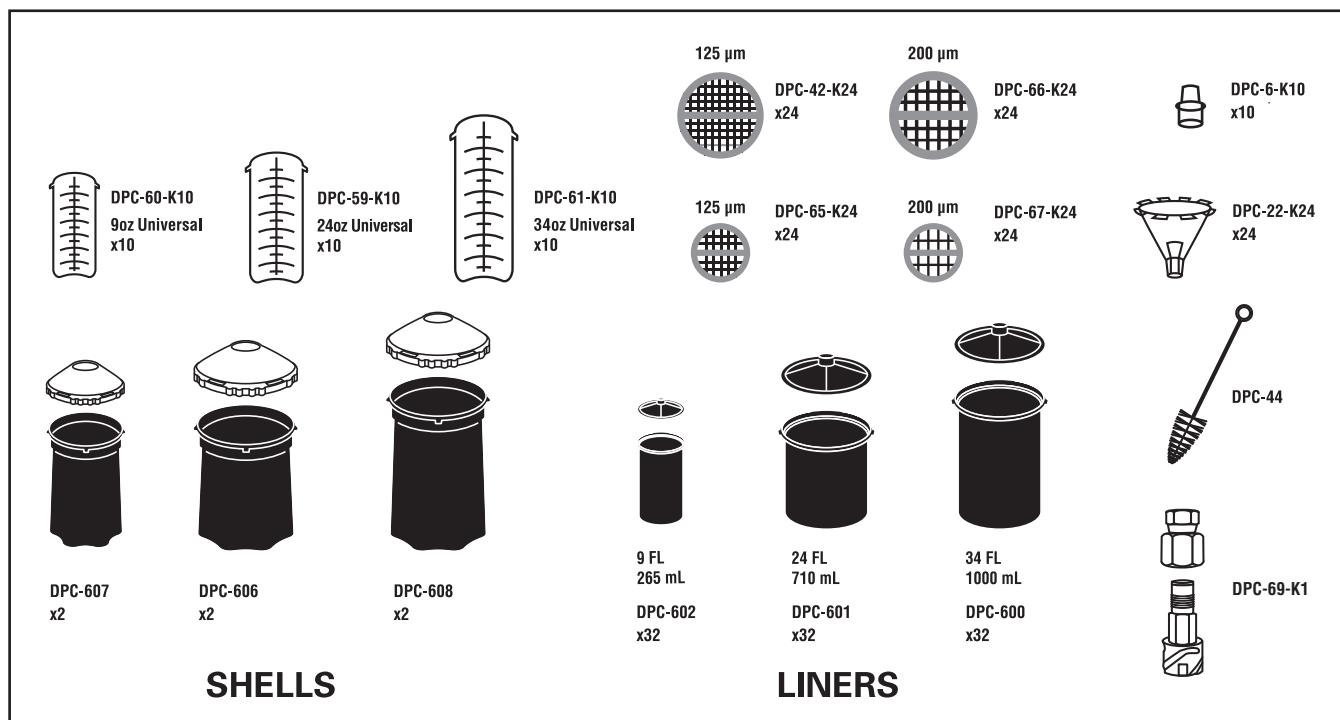

FLG4-488-K ▼ FLG4 Gun Repair Kit (Contains 1 each: Fluid Tip Seal, Needle Packing, Trigger Stud, Trigger Screw, and Gasket for Air Valve & Needle Bushing.)

Additional Spray Gun Accessories on page 9.

DeKUPS® ACCESSORIES



TROUBLESHOOTING

| CONDITION | CAUSE | CORRECTION |
|--|---|--|
| Heavy top or bottom pattern  | Horn holes plugged. Obstruction on top or bottom of fluid tip. Cap and/or tip seat dirty. | Clean. Ream with non-metallic point. Clean. Clean. |
| Heavy right or left side pattern  | Left or right side horn holes plugged. Dirt on left or right side of fluid tip. | Clean. Ream with non-metallic point. Clean. |
| Heavy center pattern  | Fluid flow too high for atomization air. Material flow exceeds air cap's capacity. Spreader adjustment valve set too low. Atomizing pressure too low. Material too thick. | Balance air pressure and fluid flow. Increase spray pattern width with spreader adjustment valve. Thin or lower fluid flow. Adjust. Increase pressure. Thin to proper consistency. |
| Split spray pattern  | Atomization air pressure too high. Fluid flow too low. Spreader adjusting valve set too high. | Reduce at transformer or gun. Increase fluid flow (increases gun handling speed). Adjust. |
| Jerky or fluttering spray  | *Loose or damaged fluid tip/seat. Material level too low. Container tipped too far. Obstruction in fluid passage. Dry or loose fluid needle packing nut. | Tighten or replace. Refill. Hold more upright. Backflush with solvent. Lubricate or tighten. |
| Unable to get round spray | Spreader adjustment screw not seating properly. Air cap retaining ring loose. | Clean or replace. Tighten. |

*Most common problem.

TROUBLESHOOTING (Continued)

| CONDITION | CAUSE | CORRECTION |
|---|---|--|
| Will not spray | No air pressure at gun. Fluid needle adjusting screw not open enough. Fluid too heavy for gravity feed. | Check air supply and air lines, blow out gun air passages. Open fluid needle adjusting screw. Thin material and/or change to larger tip size. |
| Paint bubbles in cup | Fluid tip not tight. | Tighten tip. |
| Fluid leaking or dripping from cup lid | Cup lid loose. Dirty threads on cup or lid. Cracked cup or lid. | Tighten lid. Clean. Replace cup and lid. |
| Starved spray pattern | Inadequate material flow. Low atomization air pressure. | Back fluid adjusting screw out to first thread, or change to larger tip size. Increase air pressure and rebalance gun. |
| Excessive overspray | Too much atomization air pressure. Gun too far from work surface. Improper stroking (arcing, gun motion too fast). | Reduce pressure. Adjust to proper distance. Move at moderate pace, parallel to work surface. |
| Excessive fog | Too much or too fast-drying thinner. Too much atomization (air pressure.) | Remix properly. Reduce air pressure. |
| Dry spray | Air pressure too high. Gun tip too far from work surface. Gun motion too fast. Gun out of adjustment. | Reduce air pressure. Adjust to proper distance. Slow down. Adjust. |
| Fluid leaking from packing nut | Packing nut loose. Packing worn or dry. | Tighten, do not bind needle. Replace or lubricate. |
| Fluid leaking or dripping from front of gun | Packing nut too tight. Dry packing. Fluid tip or needle worn or damaged. Foreign matter in tip. Fluid needle spring broken. Wrong size needle or tip. | Adjust. Lubricate. Replace tip and needle. Clean. Replace. Replace. |
| Fluid dripping or leaking from bottom of cup | Cup loose on gun. Cup gasket worn or missing below cup. Cup threads dirty. | Tighten. Replace cup gasket. Clean. |
| Runs and sags | Too much material flow. Material too thin. Gun tilted on an angle, or gun motion too slow. | Adjust gun or reduce fluid flow. Mix properly or apply light coats. Hold gun at right angle to work and adapt to proper gun technique. |
| Thin, sandy coarse finish drying before it flows out | Gun too far from surface. Too much air pressure. Improper thinner being used. | Check distance. Normally approximately 8". Reduce air pressure and check spray pattern. Follow paint manufacturer's mixing instructions. |
| Thick, dimpled finish "orange peel" | Gun too close to surface. Too much material coarsely atomized. Air pressure too low. Improper thinner being used. Material not properly mixed. Surface rough, oily, dirty. | Check distance. Normally approximately 8". Follow paint manufacturer's mixing instructions. Increase air pressure or reduce fluid flow. Follow paint manufacturer's mixing instructions. Follow paint manufacturer's mixing instructions. Properly clean and prepare. |

ACCESSORIES

HAF-507-K12
Whirlwind™ In-Line Air Filter
 Kit of 12

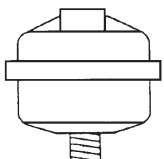

Removes water, oil, and debris from the air line.

TGC-545 Aluminum
TLC-555 (Non-stick Coated)
TCS-595 Stainless Steel
Drip Free Suction Cups

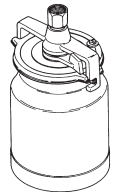

Cups have a unique, two position valve which permits selection of either a drip free or conventional open vent mode.

Spray Gun
Lube
SSL-10-12
(Twelve
2 oz.
bottles)



Compatible with all paint materials; contains no silicone or petroleum distillates to contaminate paint. MSDS available upon request.

HAV-500 OR HAV-501
Adjusting Valve
(HAV-501 SHOWN)

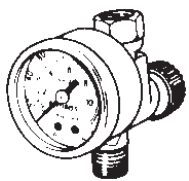

HAV-500 does not have pressure gauge. Use to control air usage at gun.

FLG-463
HVLP Air Cap Test Kit
(#3 air cap)



The purpose of this test kit is to measure air cap atomizing air pressure at the center air port of the air cap. Used to confirm code compliance and as a daily quality control measure.

Millennium 3000
Twin Cartridge
Paint Spray Respirator



NIOSH-Certified, for respiratory protection in atmospheres not immediately dangerous to life.

| | | |
|--------|--------|--------|
| Small | Medium | Large |
| 40-141 | 40-128 | 40-143 |

192212 Professional Spray Gun
Cleaning Kit



Contains six precision tools designed to effectively clean all DeVilbiss, Binks, Finishline and other brand spray guns.

WR-103 Wrench

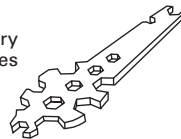

Contains all necessary tip, hose and nut sizes used on or with gun.

192219
Gun Holder

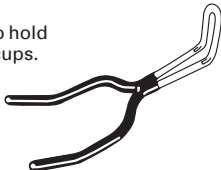

Gun holder made to hold guns with gravity cups.

Quick Connects For HVLP Guns (Air)
 High Flow Type



| | |
|--|--|
| HC-4419 Stem 1/4" NPT(F) Gun End | HC-4719 Coupler 1/4" NPT(M) Hose End |
|--|--|

29-3100 Scrubs®
Hand Cleaner
Towels



Scrubs® are a pre-moistened hand cleaner towel for painters, body men and mechanics that go where you go and no water is needed.

WARRANTY POLICY

This product is covered by Carlisle Fluid Technologies' materials and workmanship limited warranty. The use of any parts or accessories, from a source other than Carlisle Fluid Technologies, will void all warranties. Failure to reasonably follow any maintenance guidance provided may invalidate any warranty.

For specific warranty information please contact Carlisle Fluid Technologies.

Carlisle Fluid Technologies is a global leader in innovative finishing technologies. Carlisle Fluid Technologies reserves the right to modify equipment specifications without prior notice.

DeVilbiss®, Ransburg®, ms®, BGK®, and Binks®
are registered trademarks of Carlisle Fluid Technologies, Inc.

©2018 Carlisle Fluid Technologies, Inc.
All rights reserved.

For technical assistance or to locate an authorized distributor,
contact one of our international sales and customer support locations.

| Region | Industrial / Automotive | Automotive Refinishing |
|---------------------------------------|--|--|
| Americas | Tel: 1-800-992-4657 Fax: 1-888-246-5732 | Tel: 1-800-445-3988 Fax: 1-800-445-6643 |
| Europe, Africa, Middle East, India | Tel: +44 (0)1202 571 111 Fax: +44 (0)1202 573 488 | |
| China | Tel: +8621-3373 0108 Fax: +8621-3373 0308 | |
| Japan | Tel: +81 45 785 6421 Fax: +81 45 785 6517 | |
| Australia | Tel: +61 (0) 2 8525 7555 Fax: +61 (0) 2 8525 7575 | |

For the latest information about our products, visit www.carlisleleft.com