

DETROIT RADIANT PRODUCTS CO.

Wiring Diagram for Suffix NFS/PFS 120V

(Electronic Detection Direct Spark Ignition System, 100% Shutoff)

Flame Sensing Element

Solid state logic circuit in control board continuously monitors spark current and flame conductance to ground through spark electrode.

TYPICAL WIRING SCHEMATIC

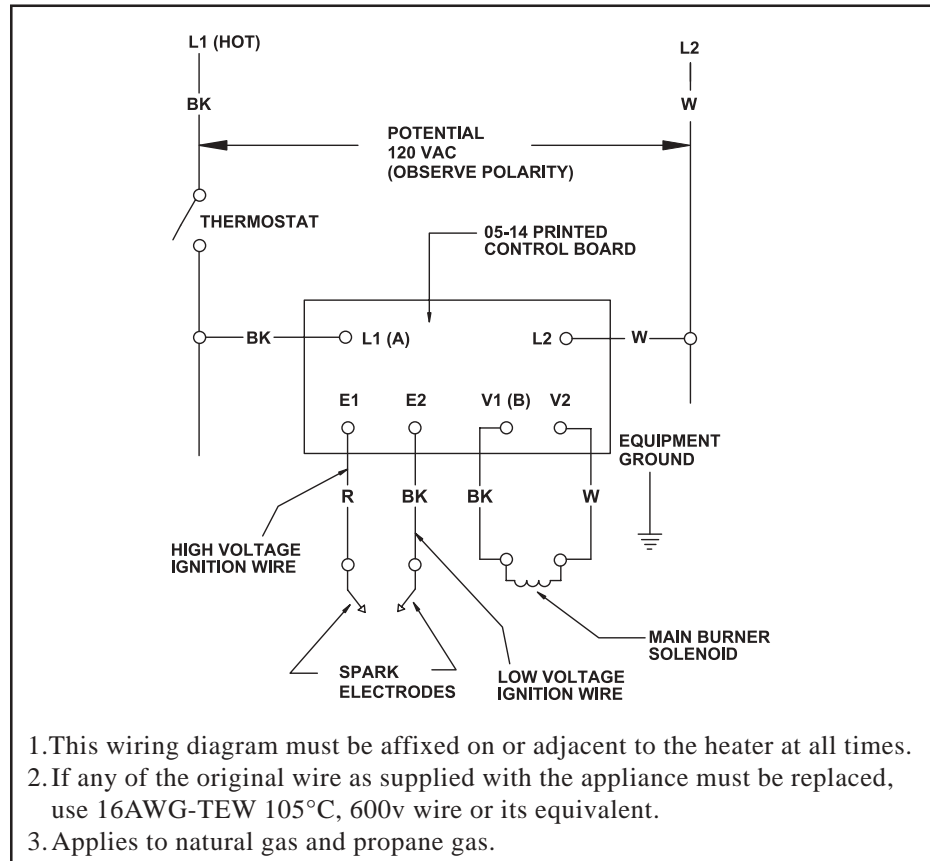

TYPICAL BLOCK DIAGRAM

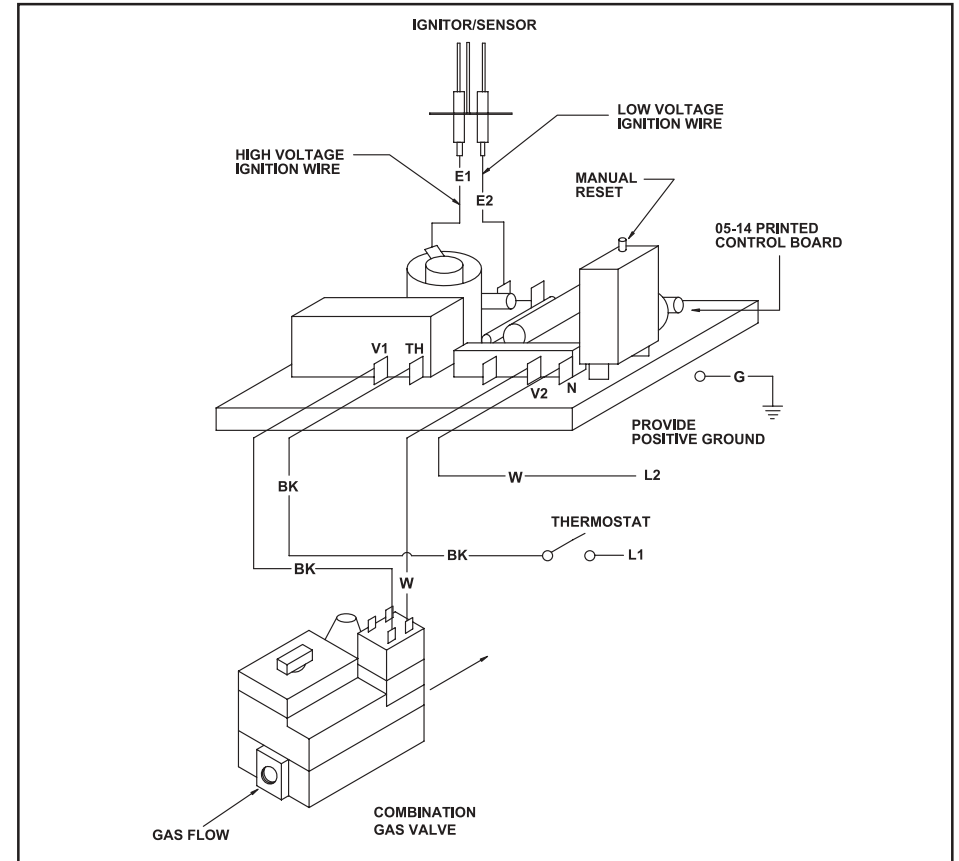

DETROIT RADIANT PRODUCTS CO.

Wiring Diagram for Suffix NFS/PFS 120V

(Electronic Detection Direct Spark Ignition System, 100% Shutoff)

Normal Sequence of Operation

Upon the closing of the electrical supply circuit to this control system, the following occurs.

1. Input power is applied to the control board, sparking is initiated and the gas valve is energized.
2. Upon ignition of the heater(s) main burner(s), current flows through the burner flame to ground. As soon as the flame is established and proven by the flames sensing circuitry, sparking will close immediately and the system will remain "ON", monitoring the flame until the end of the cycle.
3. If flame has not been established by the end of the 10 second trial for ignition period, the system will lockout, the gas valve will close, and the system must be reset by an interruption in the power source.
4. Should flame outage occur during the duty cycle, the system will reactivate the spark to provide for re-ignition. The flame will either be reestablished or operation #3 above will occur.
5. If several attempts at thermostat reset or momentary power source interruption do not result in ignition, a manual reset button on the ignition control board will actuate, preventing further cycling and must be depressed before the unit can recycle.

