

# LADDER DIAGRAM - MARK17DU-117 WITH THERMO

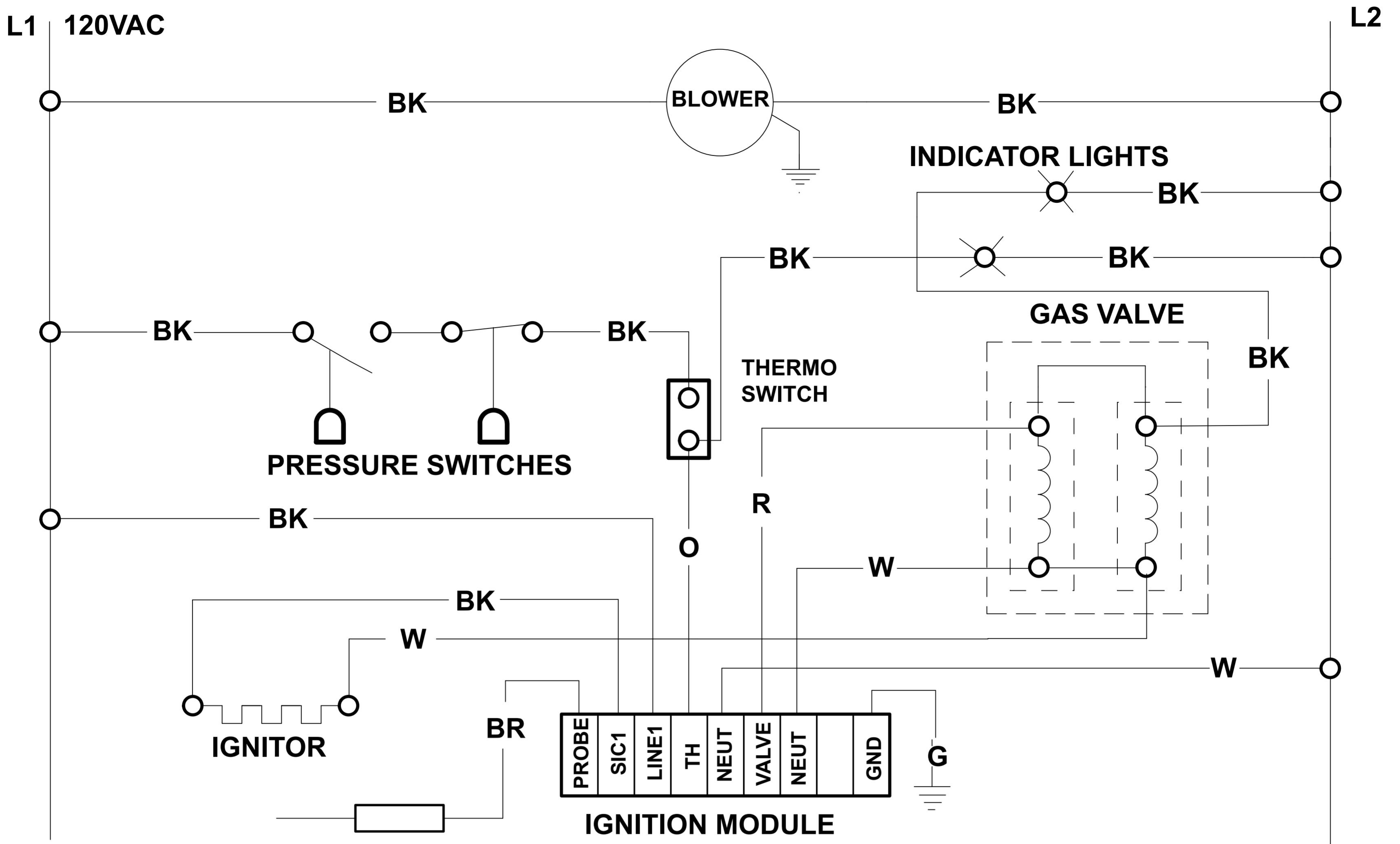

IF ANY OF THE ORIGINAL WIRE AS SUPPLIED WITH THE APPLIANCE MUST BE REPLACED, IT MUST BE REPLACED WITH WIRING MATERIAL HAVING A TEMPERATURE RATING OF AT LEAST 105 C.

# BLOCK DIAGRAM - MARK17DU-117 WITH THERMO

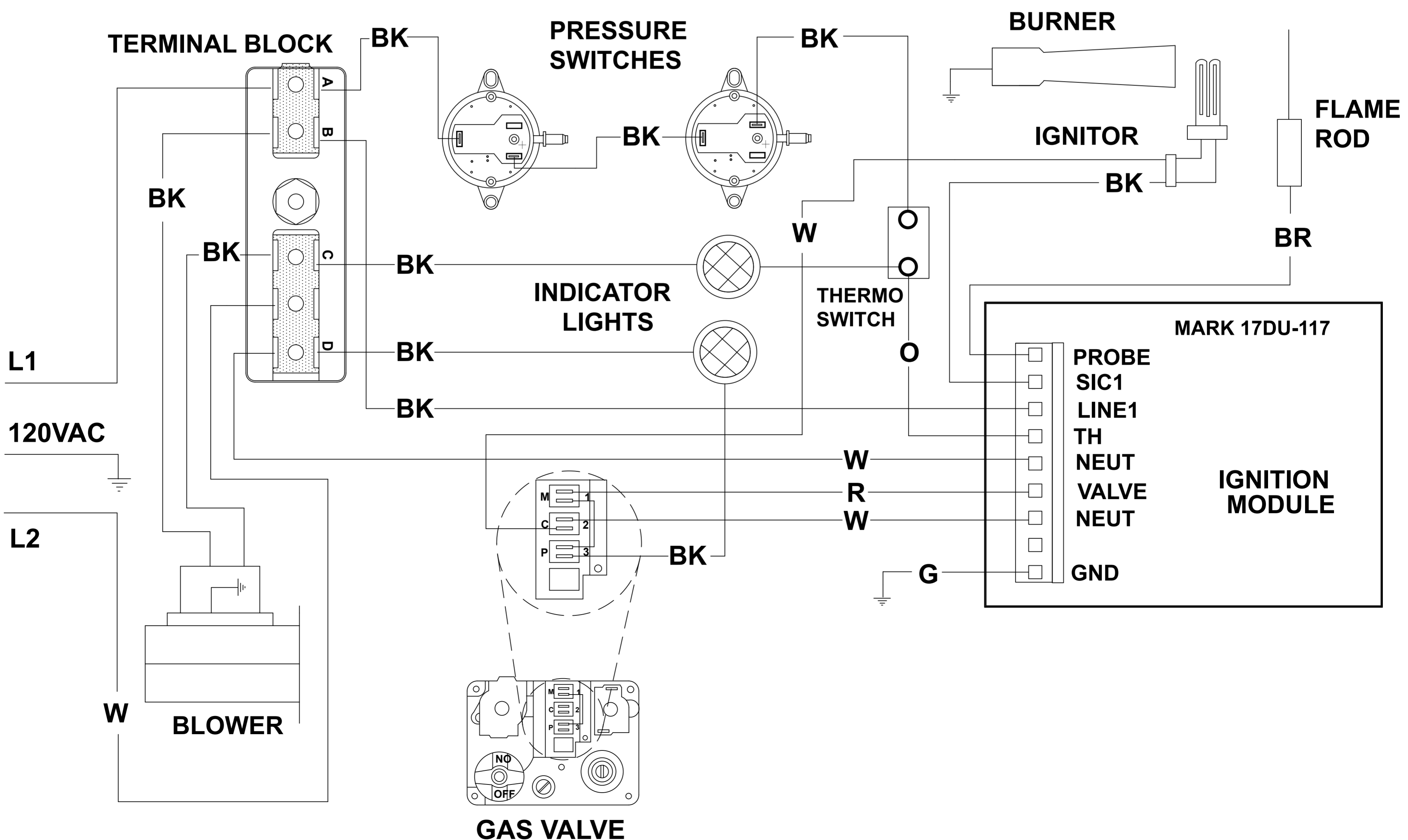

# LADDER DIAGRAM - MARK17DU-117 WITH THERMO INTERNAL RELAY OPTION

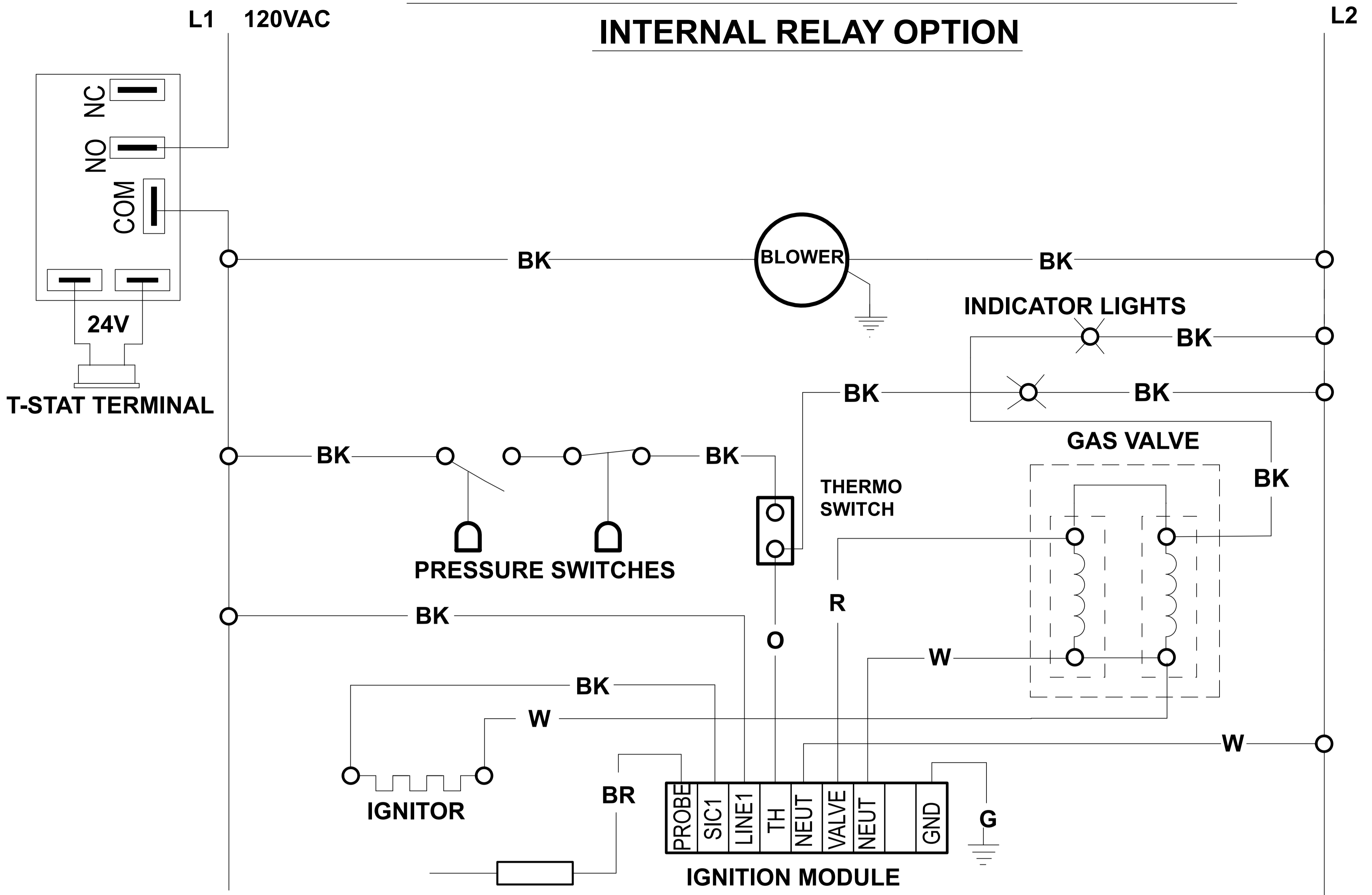

IF ANY OF THE ORIGINAL WIRE AS SUPPLIED WITH THE APPLIANCE MUST BE REPLACED, IT MUST BE REPLACED WITH WIRING MATERIAL HAVING A TEMPERATURE RATING OF AT LEAST 105 C.

# BLOCK DIAGRAM - MARK17DU-117 WITH THERMO & INTERNAL RELAY OPTION

