

WIRING DIAGRAM

DIAGRAM:

LLWT102 DES3 SERIES

WIRING INFORMATION:

LINE VOLTAGE:

FACTORY STANDARD _____
 FACTORY OPTION -----
 FIELD INSTALLED - - - - -

LOW VOLTAGE:

FACTORY STANDARD _____
 FACTORY OPTION -----
 FIELD INSTALLED - - - - -

NOTES:

IF ANY OF THE ORIGINAL WIRE AS SUPPLIED WITH THE APPLIANCE MUST BE REPLACED, IT MUST BE REPLACED WITH WIRING MATERIAL HAVING THE RATING OF AT LEAST 600V 105°C

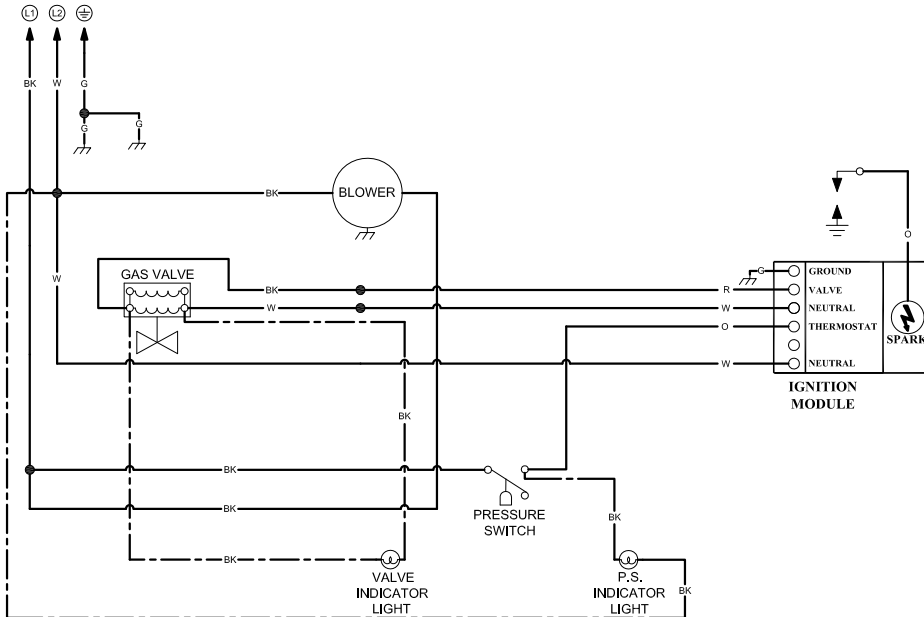

COMPONENT CODES

⊕ EARTH GROUND	TRANSFORMER	PRESSURE SWITCH
CHASSIS GROUND	BLOWER MOTOR	S.P.S.T. RELAY
Ⓛ LINE VOLTAGE	HOT SURFACE IGNITER	INDICATOR LIGHT
Ⓝ NEUTRAL	SPARK IGNITER	GAS VALVE
● WIRE NUT	FLAME SENSOR	QUICK-CONNECT TERM.

WIRING COLORS:

BK.....BLACK
 BN.....BROWN
 R.....RED
 O.....ORANGE
 Y.....YELLOW
 G.....GREEN
 BL.....BLUE
 PR.....PURPLE
 W.....WHITE
 GY.....GRAY
 PK.....PINK

VOLTAGE:

120VAC

FREQUENCY:

60Hz

PHASE:

SINGLE

REVISION:

2

LITERATURE NUMBER:

LLWT 102-1M-10/14 (CDS)