

WIRING DIAGRAM

DIAGRAM:

LLWT101 DET3 SERIES

WIRING INFORMATION:

LINE VOLTAGE:

FACTORY STANDARD _____
FACTORY OPTION _____
FIELD INSTALLED _____

LOW VOLTAGE:

FACTORY STANDARD _____
FACTORY OPTION _____
FIELD INSTALLED _____

NOTES:

IF ANY OF THE ORIGINAL WIRE AS SUPPLIED WITH THE APPLIANCE MUST BE REPLACED, IT MUST BE REPLACED WITH WIRING MATERIAL HAVING THE RATING OF AT LEAST 600V 105°C

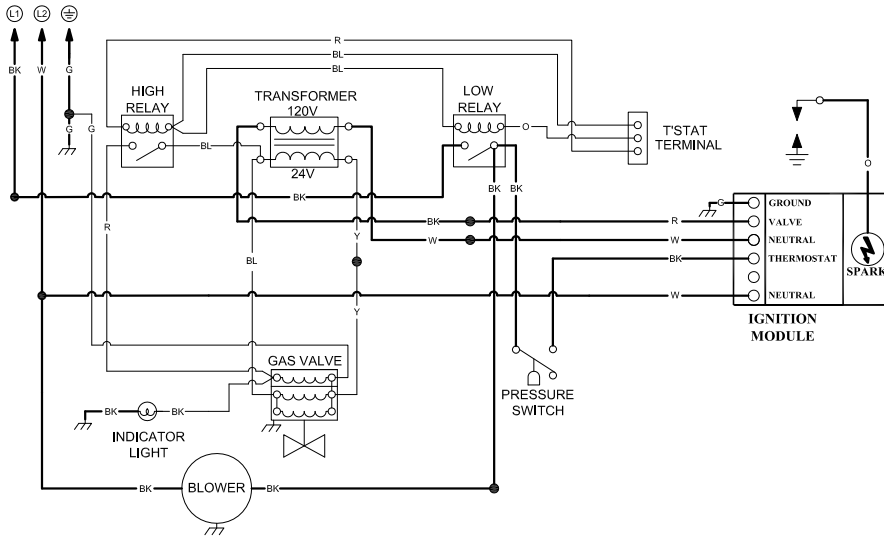

COMPONENT CODES

⊕ EARTH GROUND	TRANSFORMER	PRESSURE SWITCH
CHASSIS GROUND	BLOWER MOTOR	S.P.S.T. RELAY
Ⓛ LINE VOLTAGE	HOT SURFACE IGNITER	INDICATOR LIGHT
Ⓝ NEUTRAL	SPARK IGNITER	GAS VALVE
● WIRE NUT	FLAME SENSOR	QUICK-CONNECT TERM.

WIRING COLORS:

BK.....BLACK
BN.....BROWN
R.....RED
O.....ORANGE
Y.....YELLOW
G.....GREEN
BL.....BLUE
PR.....PURPLE
W.....WHITE
GY.....GRAY
PK.....PINK

VOLTAGE:	FREQUENCY:	PHASE:
120VAC	60Hz	SINGLE

REVISION:	LITERATURE NUMBER:
1	LLWT 101-1M-08/12 (CDS)