

WIRING DIAGRAM

DIAGRAM:

LLWT039

HL2/RVA2 SERIES w/ HLRB

WIRING INFORMATION:

LINE VOLTAGE:

FACTORY STANDARD _____
 FACTORY OPTION _____
 FIELD INSTALLED _____

LOW VOLTAGE:

FACTORY STANDARD _____
 FACTORY OPTION _____
 FIELD INSTALLED _____

NOTES:

IF ANY OF THE ORIGINAL WIRE AS SUPPLIED WITH THE APPLIANCE MUST BE REPLACED, IT MUST BE REPLACED WITH WIRING MATERIAL HAVING THE RATING OF AT LEAST 600V 105°C

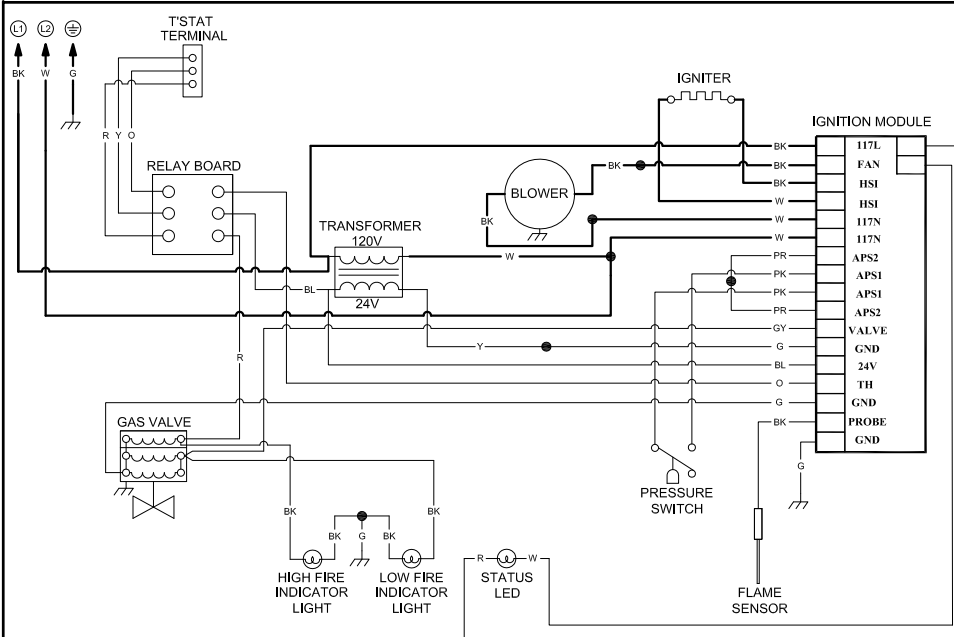

COMPONENT CODES

⊕	EARTH GROUND		TRANSFORMER		PRESSURE SWITCH
	CHASSIS GROUND		BLOWER MOTOR		S.P.S.T. RELAY
Ⓛ	LINE VOLTAGE		HOT SURFACE IGNITER		INDICATOR LIGHT
Ⓝ	NEUTRAL		SPARK IGNITER		GAS VALVE
●	WIRE NUT		FLAME SENSOR		QUICK-CONNECT TERM.

WIRING COLORS:

BK.....BLACK
 BN.....BROWN
 R.....RED
 O.....ORANGE
 Y.....YELLOW
 G.....GREEN
 BL.....BLUE
 PR.....PURPLE
 W.....WHITE
 GY.....GRAY
 PK.....PINK

VOLTAGE:	FREQUENCY:	PHASE:
120VAC	60Hz	SINGLE
REVISION:	LITERATURE NUMBER:	
2	LLWT039-1M-05/13 (CDS)	