

Before field wiring this appliance - Check existing wiring; replace if necessary.

Note: If any of the original wire supplied with the appliance must be replaced, it must be replaced with wiring material having a temperature rating of at least 105° C.

Figure 2.2 • Internal Wiring Diagrams

A. Micro 60U-24 Ladder Diagram

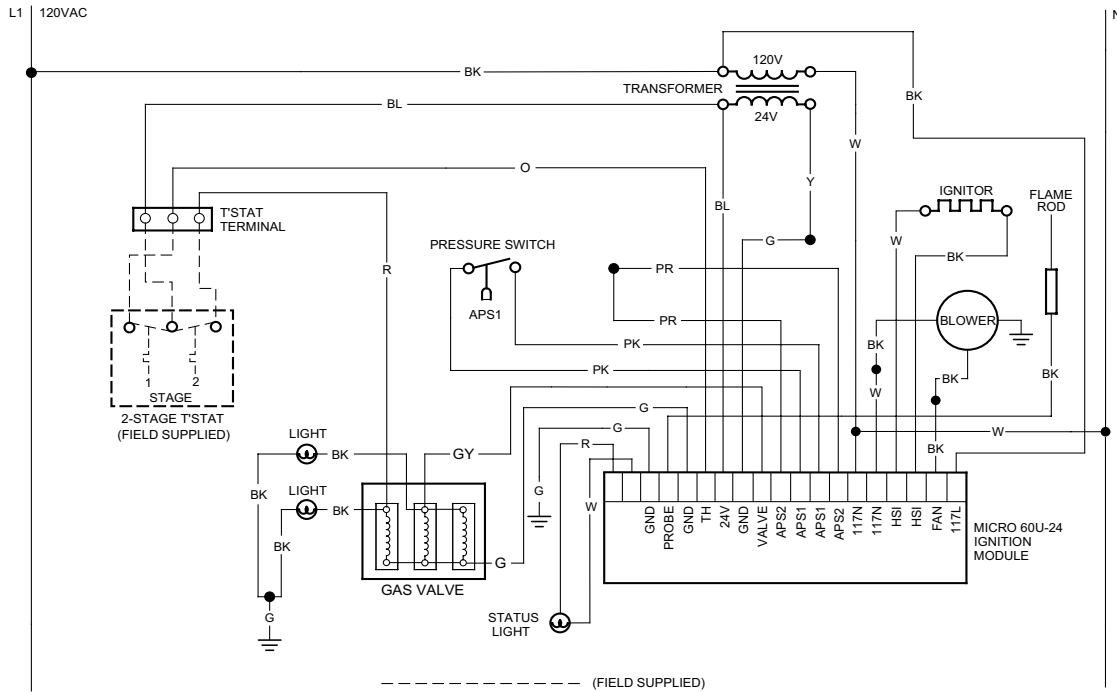

B. Micro 60U-24 Block Diagram

