

Before field wiring this appliance - Check existing wiring; replace if necessary.

Note: If any of the original wire as supplied with the appliance must be replaced, it must be replaced with wiring material having a temperature rating of at least 105° C.

Figure 2.3 • Internal Wiring Diagrams

A. TP-351A Ladder Diagram

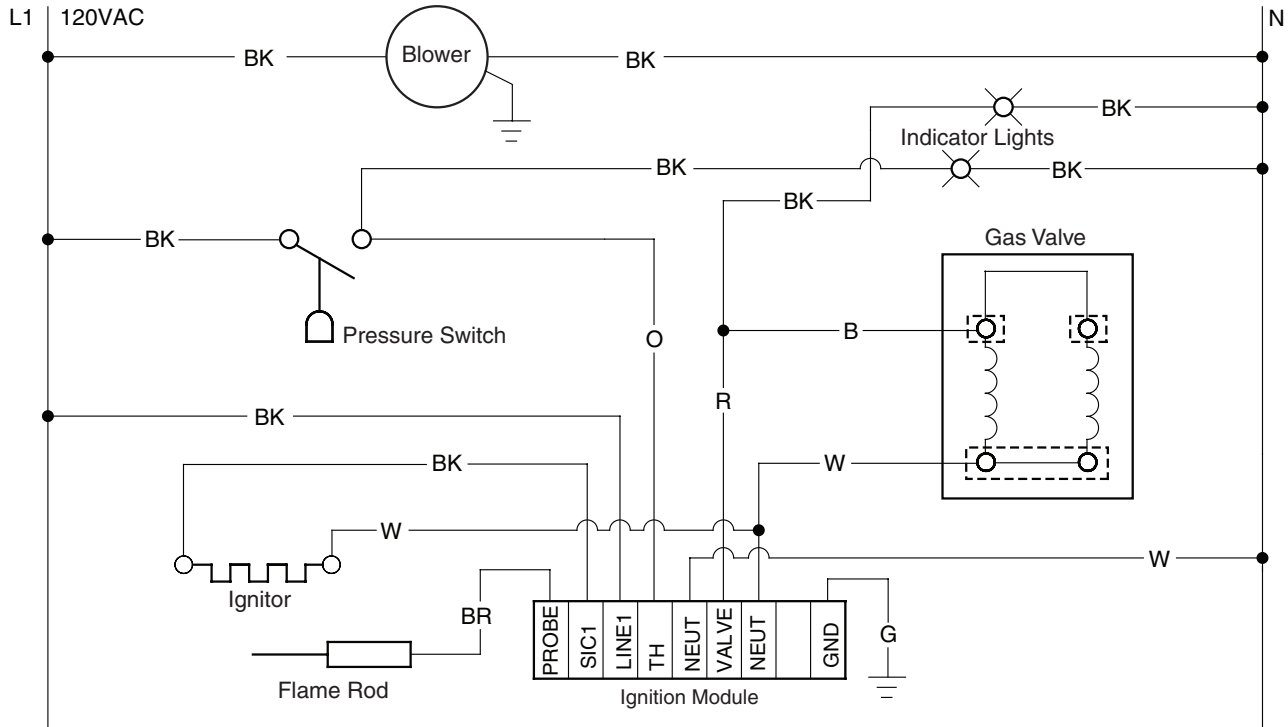

B. TP-351A Block Diagram

