

WIRE SIZE AWG	WIRE SIZE METRIC	INSULATION DIAMETER REF.	UNSEALED NOT GREASED	SEALED NOT GREASED	UNSEALED GREASED NYE-160 U/V	UNSEALED GREASED NYE-8917	SEALED GREASED NYE-160 U/V	GAGE STAMP	A	B	(C) DIA	C2	(D) DIA	D2	(J)	(K)	L	(V)	(W)	TYPE OF GRIP
10/12	4.0/6.0	4.3/3.0																		SEALED
12	3.0	3.4/3.0																		UNSEALED
14/16	2.5/1.5	2.8/2.1																		SEALED
18/20	1.0/0.5	2.2/1.4																		UNSEALED
2 (18/20)	2 (1.0/0.5)	2.2/1.4 PER WIRE																		UNSEALED
22	0.35	1.8/1.2																		SEALED
																				UNSEALED

CABLE SEAL (CS) (UNSEAL)	WIRE SIZE AWG	WIRE SPEC. AWG	WIRE SIZE METRIC	WIRE SPEC. METRIC	CONDUCTOR CRIMP HEIGHT (SECT C-C) (+/-0.05)	CONDUCTOR CRIMP HEIGHT METRIC (SECT C-C) (+/-0.05)	CONDUCTOR CRIMP WIDTH (SECT C-C) (+/-0.10)	INSULATION CRIMP HEIGHT (SECT D-D) (+/-0.05)	INSULATION CRIMP HEIGHT METRIC (SECT D-D) (+/-0.05)	INSULATION CRIMP WIDTH (SECT D-D) (+/-0.10)	INSULATION CRIMP PUNCH OPTION	INSL. GRIP FORM TYPE SECT-D
US	22		0.35		1.10	1.10	1.85	1.75	1.65	2.60		2
CS	18		0.75/1.00		1.30	1.30/1.40		4.00	2.10			2
	20		0.50		1.20	1.25		3.85	2.00	3.30		2
US	20		0.75/1.00		1.30	1.30/1.40	2.05	2.35	2.10/2.30			2
	20		0.50		1.20	1.25		2.20	2.00	2.60	OPTION 2	2
CS	14		2.00/2.50		1.70	1.80*/1.90		4.40	4.10/4.25			2
	16		1.50		1.50	1.40*		4.25	4.05*/4.15*	4.40		2
US	16		2.00/2.50		1.70	1.80*/1.90	2.45	2.70	3.00*/3.10			2
	16		1.50		1.50	1.40*		2.60	2.55*/2.65	3.20		2
US	2(18-20)		2(1.50/1.00)		VARIABLE	VARIABLE	3.05	VARIABLE	VARIABLE	4.30	OPTION 1	1
CS	12		3.00		3.00			4.80*	4.40*	4.80*		2
US	12		3.00		1.95	1.95	3.45	3.10	3.30	3.85	OPTION 2	2
CS	10		5.00/6.00		2.25	2.40*/2.50*		N/A	N/A			2
	12		4.00		1.95	2.05		N/A	N/A	N/A		2
US	10		5.00/6.00		2.25	2.40*/2.50*		4.20	4.30			1
	12		4.00		1.95	2.05		USE 12 GA TERMINAL	3.90		OPTION 1	2

* NOT VERIFIED TO USCAR-21

CRIMP WIDTH	CORE/INSULATION	INSULATION CRIMP OPTION	E ±0.03	F ±0.03	G ±0.03	J ±0.03	K ±0.03	L ±0.03 OFFSET BETWEEN ANVILS	M ±0.03	N ±0.03	P ±0.03	R ±0.03	S ±0.03	T ±0.03	U ±0.03
1.85	CONDUCTOR	---	0.83	0.48	0.11	2.31	1.79	---	1.78	---	---	---	---	---	---
2.05	CONDUCTOR	---	0.92	0.53	0.12	2.56	1.99	---	1.97	---	---	---	---	---	
2.45	CONDUCTOR	---	1.09	0.63	0.16	3.06	2.38	---	2.36	---	---	---	---	---	
2.60	INSULATION	2	---	---	---	---	---	0.00	---	0.18	3.25	2.53	2.50	N/A	
3.05	CONDUCTOR	---	1.36	0.79	0.22	3.81	2.96	---	---	---	---	---	---	---	
3.20	INSULATION	2	---	---	---	---	---	0.40	---	0.23	4.00	3.11	3.08	N/A	
3.30	INSULATION	2	---	---	---	---	---	0.60	---	0.24	4.12	3.20	3.17	N/A	
3.45	CONDUCTOR	---	1.54	0.89	0.26	4.31	3.35	---	3.32	---	---	---	---	---	
3.85	INSULATION	2	---	---	---	---	---	0.80	---	0.30	4.81	3.74	3.70	---	
4.40	INSULATION	2	---	---	---	---	---	0.80	---	0.35	5.50	4.27	4.23	---	
4.20	INSULATION	1	---	---	---	---	---	0.80	4.04	0.33	5.25	4.08	4.04	1.87	
4.80	INSULATION	2	---	---	---	---	---	1.10	---	0.38	5.10	4.70	4.64	---	
4.30	INSULATION	1	---	---	---	---	---	0.60	---	0.34	5.38	4.17	4.13	1.92	

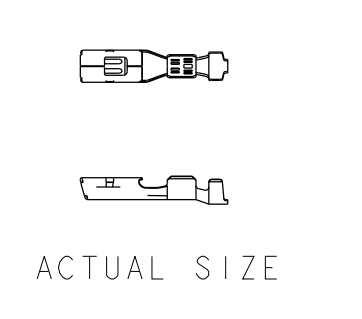

- FIRST SUFFIX NUMBER AFTER THE PART NUMBER IS THE MATERIAL TYPE FOR THE TERMINAL BODY
- SECOND NUMBER AFTER THE PART NUMBER IS THE SPRING MATERIAL TYPE
- LINE THRU THE PART NUMBER INDICATES IT IS NOT AVAILABLE FOR PRODUCTION

MATERIAL TYPE	BODY: TYPE 1 SPRING: TYPE 2	BODY: TYPE 3 SPRING: TYPE 4	BODY: TYPE 5 SPRING: TYPE 4	BODY: TYPE 6 SPRING: TYPE 4
PLATING	TIN (230)	GOLD INLAY (20)	GOLD SPOT, STRIPE (20)	SILVER STRIPE, SPOT (20)
PRE-NOTCH STRIP?	NO	NO	YES	NO
ZONE "A" (230)	HOT TIN DIP 0.0005mm-0.0025mm	BOTH SIDES: SULFAMATE DUCTILE NICKEL 0.0005mm MIN PER ASTM B689 TYPE 2 (20)	BOTH SIDES: SULFAMATE DUCTILE NICKEL 0.0005mm MIN PER ASTM B689 TYPE 2 (20)	BOTH SIDES: SULFAMATE DUCTILE NICKEL 0.0005mm MIN PER ASTM B689 TYPE 2 (20)
ZONE "B" (231)	HOT TIN DIP 0.0005mm-0.0025mm NO NICKEL IN THIS AREA (20)	BOTH SIDES: 100% ELECTROMATTE TIN 0.00254-0.0038mm, PER ASTM B545 (20)	BOTH SIDES: 100% ELECTROMATTE TIN 0.00254-0.0038mm, PER ASTM B545 (20)	BOTH SIDES: 100% ELECTROMATTE TIN 0.00254-0.0038mm, PER ASTM B545 (20)
ZONE "C" (232)	---	SEE GOLD INLAY VIEW BELOW FOR INLAY DETAILS (20)	RAISED RIB SIDE ONLY: SULFAMATE DUCTILE NICKEL, STRIPE PLATE (20) 0.0013-0.0025mm PER ASTM B689 TYPE 2 (20)	ELECTRO DEPOSITED PURE SILVER (20) UNDER 99.0% PURE HARD GOLD CAP (20) SPOT PLATE 0.0005mm MIN PER ASTM B488-01 TYPE 2 CODE C (20)
ZONE "D" (233)	---	BOTH SIDES, TRANSITION AREA, (TIN AND NICKEL MUST OVERLAP). MUST HAVE MINIMUM OF 0.0005mm OF NICKEL PLATING BOTH SIDES (20)	BOTH SIDES, TRANSITION AREA, (TIN AND NICKEL MUST OVERLAP). MUST HAVE MINIMUM OF 0.0005mm OF NICKEL PLATING BOTH SIDES (20)	BOTH SIDES, TRANSITION AREA, (TIN AND NICKEL MUST OVERLAP). MUST HAVE MINIMUM OF 0.0005mm OF NICKEL PLATING BOTH SIDES (20)

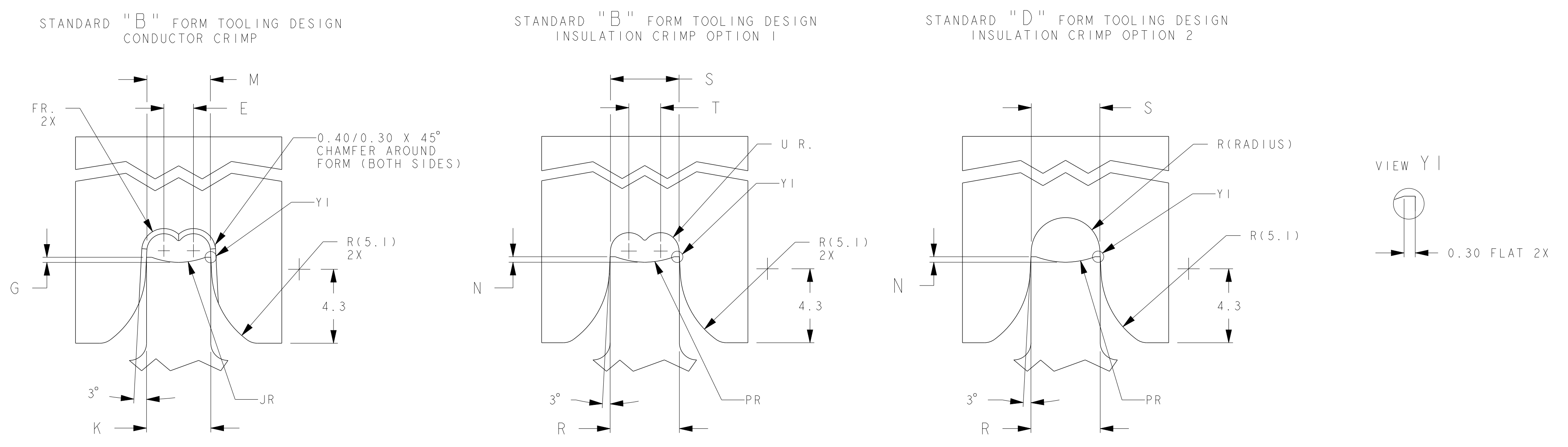
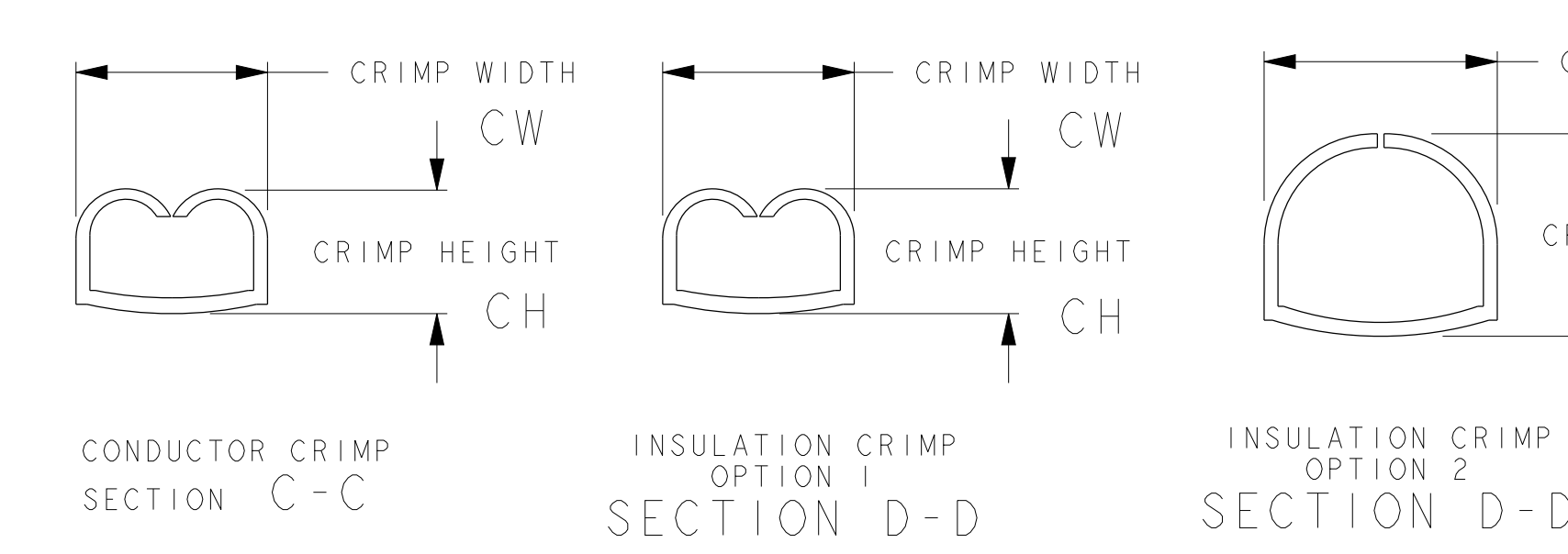

CRIMP TOOL INFORMATION (REF. ONLY)

- NOTES:
- CONFORMS TO ALL APPLICABLE SECTIONS OF SAE/USCAR-21 REV. 3 EXCEPT TERMINAL BEND RESISTANCE SECTION B-2.2 SAE/USCAR-12 REV 2 SAE/USCAR-21 FORD SDS VER 11
 - TERMINAL SYMMETRICAL ABOUT CENTERLINE EXCEPT AS SHOWN.
 - DIMENSIONAL TOLERANCE: 1 PLACE ±0.25 2 PLACE ±0.10 ANGULAR ±3°
 - FOR CAVITY SPECIFICATION INFORMATION REFERENCE F.C.I.L. DRAWING 15001 FOR UNSEALED CAVITY AND F.C.I.L. DRAWING C15006 FOR SEALED CAVITY
 - SEE USCAR DRAWING EWCAP-001 FOR DIRECT CONNECT MATING BLADE INFORMATION
 - ANNUAL QUALITY REQUIREMENTS: IT IS PERMISSIBLE TO PERFORM CONTINUOUS CONFORMANCE PER FCI SPECIFICATION #AQA-001 INSTEAD OF ANNUAL LAYOUT & ANNUAL PV REQUIREMENTS OF QS-9000 SECTION 2 - CURRENT PRODUCTION TOOLING - POINT OF LAST RUN.
 - QUALITY ASSURANCE REQUIREMENTS PER DCA PS-7300:(2)
 - INDICATES IN-PROCESS INSPECTION FOR MANUFACTURING DIMENSIONS OR SPECIFICATIONS. (13)
 - INDICATES IN-PROCESS GAGE INSPECTION FOR MANUFACTURING DIMENSIONS. (2)
- NOTES:
- SUFFIX NUMBER AFTER PART NUMBER IN THE CHARTS INDICATE THE BODY MATERIAL, AND SPRING MATERIAL.
- (20) MATERIAL TYPE 1: C14530 CU TO ASTM B-152 THICKNESS 0.305 ± 0.008
 - (20) TENSILE STRENGTH: 372 - 442 Mpa
 - (20) MIN. ELONGATION: 2.5% IN 51mm
 - (20) TIN PLATED, SEE PLATING CHART FOR INFORMATION
 - (20) MATERIAL TYPE 2: C17140 BE CU TO ASTM B-768 THICKNESS 0.203 ± 0.008
 - (20) TENSILE STRENGTH: 758-897 Mpa
 - (20) YIELD STRENGTH: 655-862 Mpa
 - (20) MIN. ELONGATION: 7% IN 51mm
 - (20) TIN PLATED, 100% HOT TIN DIP 0.0005mm - 0.0025 mm
 - (20) MATERIAL TYPE 3: C14530 CU TO ASTM B-152 THICKNESS 0.305 ± 0.008
 - (20) TENSILE STRENGTH: 324 - 394 Mpa
 - (20) MIN. ELONGATION: 2.5% IN 51mm
 - (20) SEE SPECIAL PLATING SECTION FOR GOLD INLAY SPECIFICATIONS.
 - (20) MATERIAL TYPE 4: C17140 BE CU TO ASTM B-768 THICKNESS 0.203 ± 0.008
 - (20) TENSILE STRENGTH: 758-897 Mpa
 - (20) YIELD STRENGTH: 655-862 Mpa
 - (20) MIN. ELONGATION: 7% IN 51mm
 - (20) NICKEL PLATED, SULFAMATE DUCTILE NICKEL 0.0013mm - 0.0025mm
 - (20) TO ASTM B-689 TYPE 2
 - (20) MATERIAL TYPE 5: C14530 CU TO ASTM B-152 THICKNESS 0.305 ± 0.008
 - (20) TENSILE STRENGTH: 324 - 394 Mpa
 - (20) MIN. ELONGATION: 2.5% IN 51mm
 - (20) SEE SPECIAL PLATING SECTION FOR SPOT GOLD SPECIFICATIONS.
 - (20) MATERIAL TYPE 6: C14530 CU TO ASTM B-152 THICKNESS 0.305 ± 0.008
 - (20) TENSILE STRENGTH: 324 - 394 Mpa
 - (20) MIN. ELONGATION: 2.5% IN 51mm
 - (20) SEE SPECIAL PLATING SECTION FOR SILVER STRIPE SPECIFICATIONS.

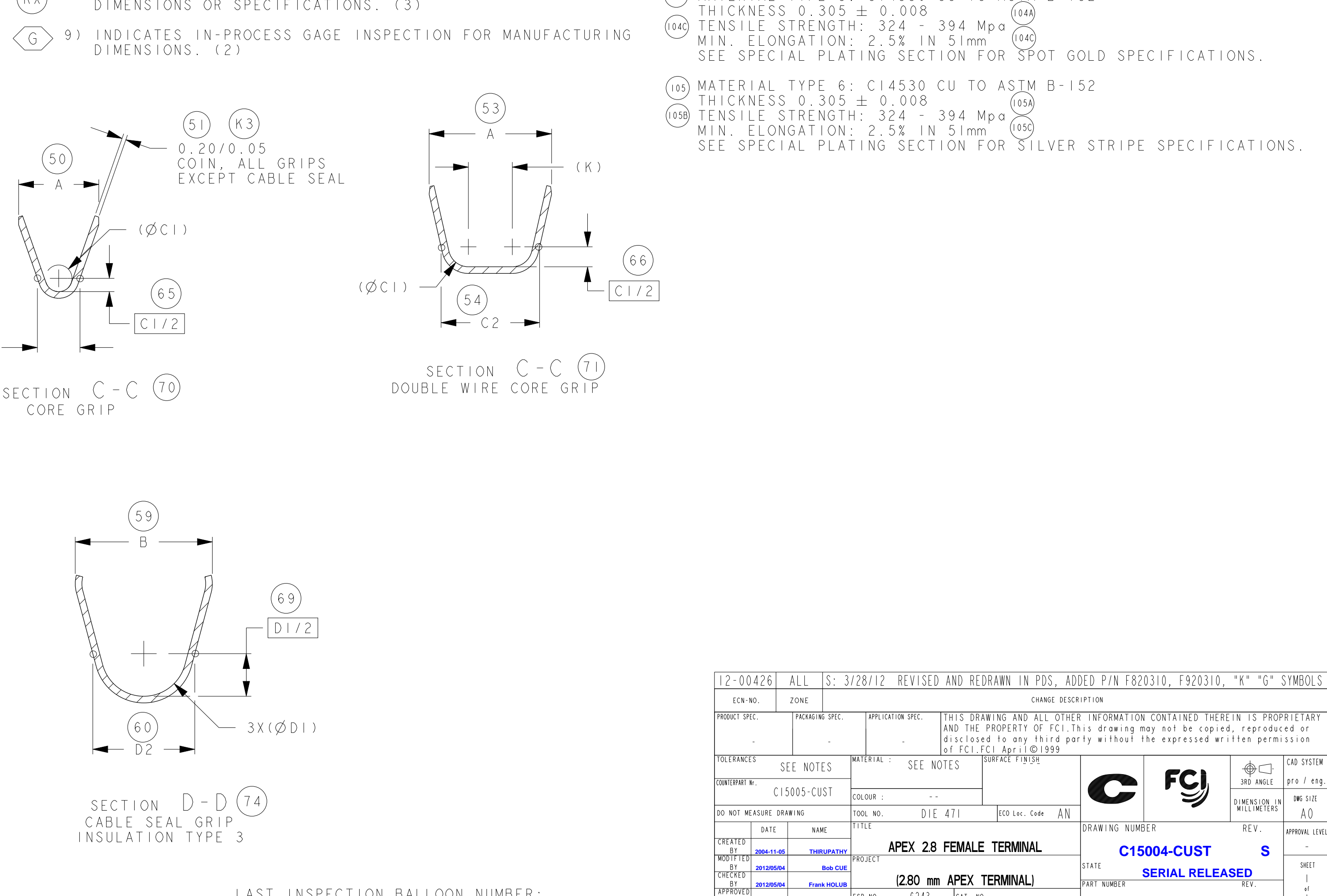
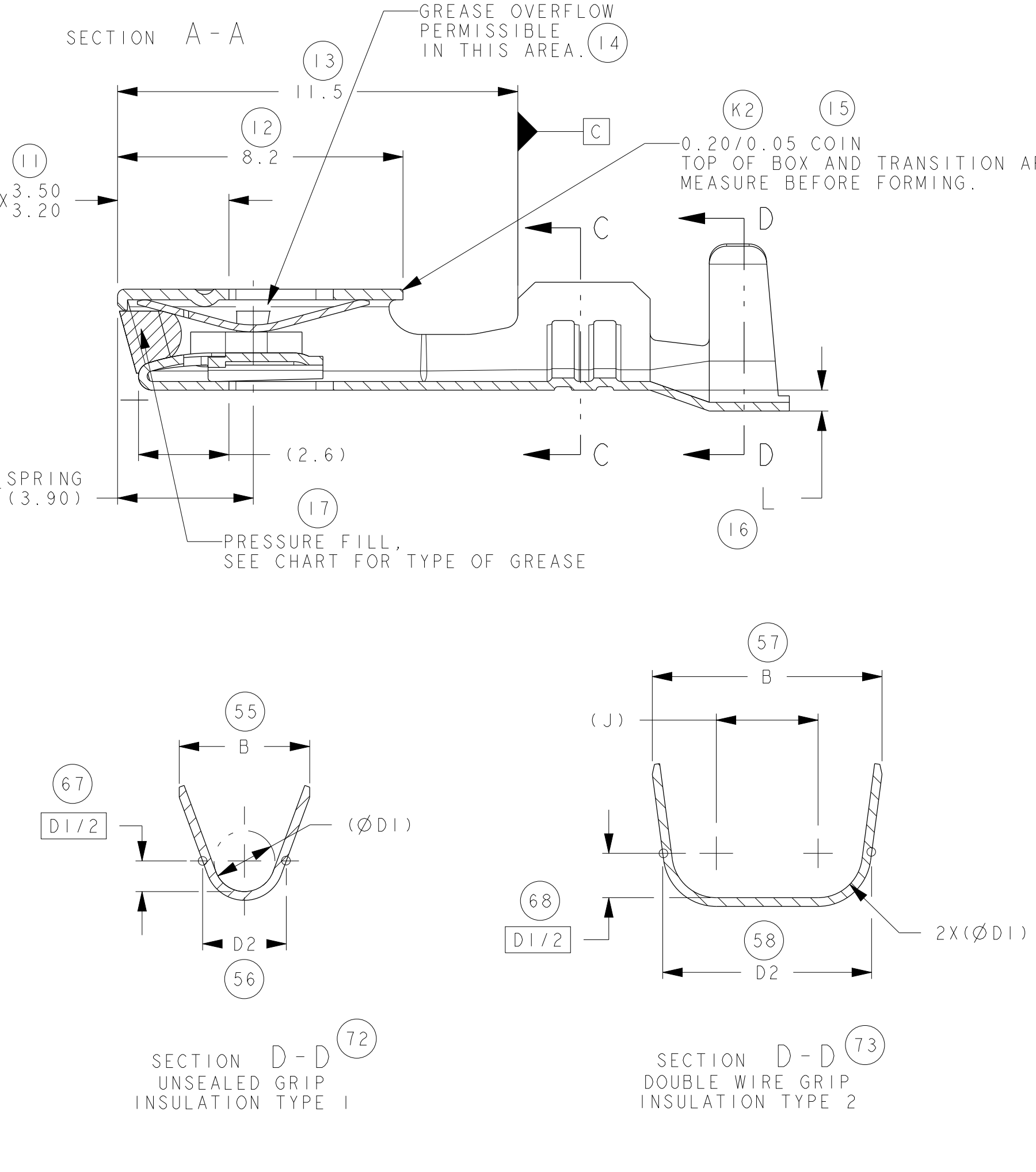
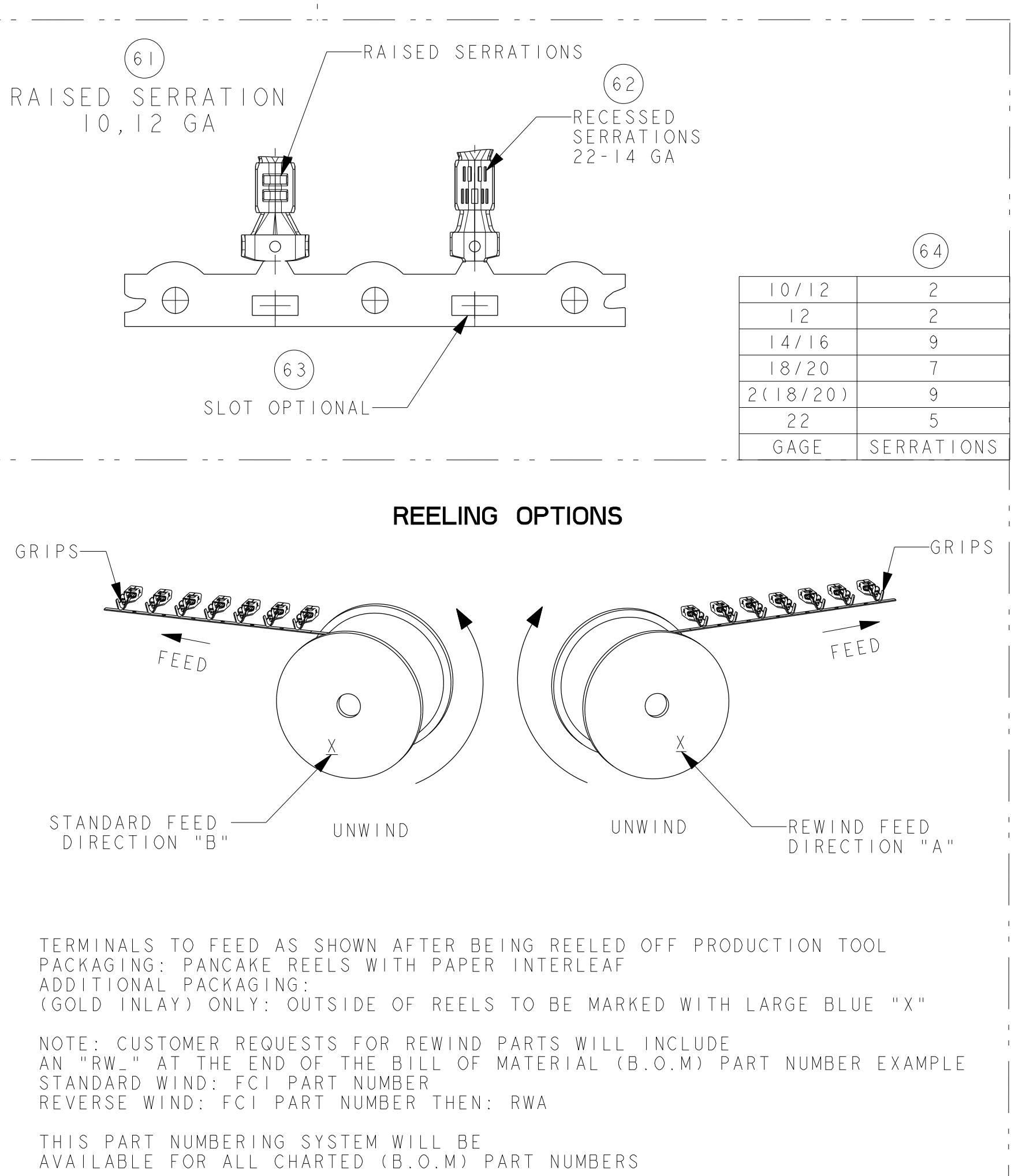
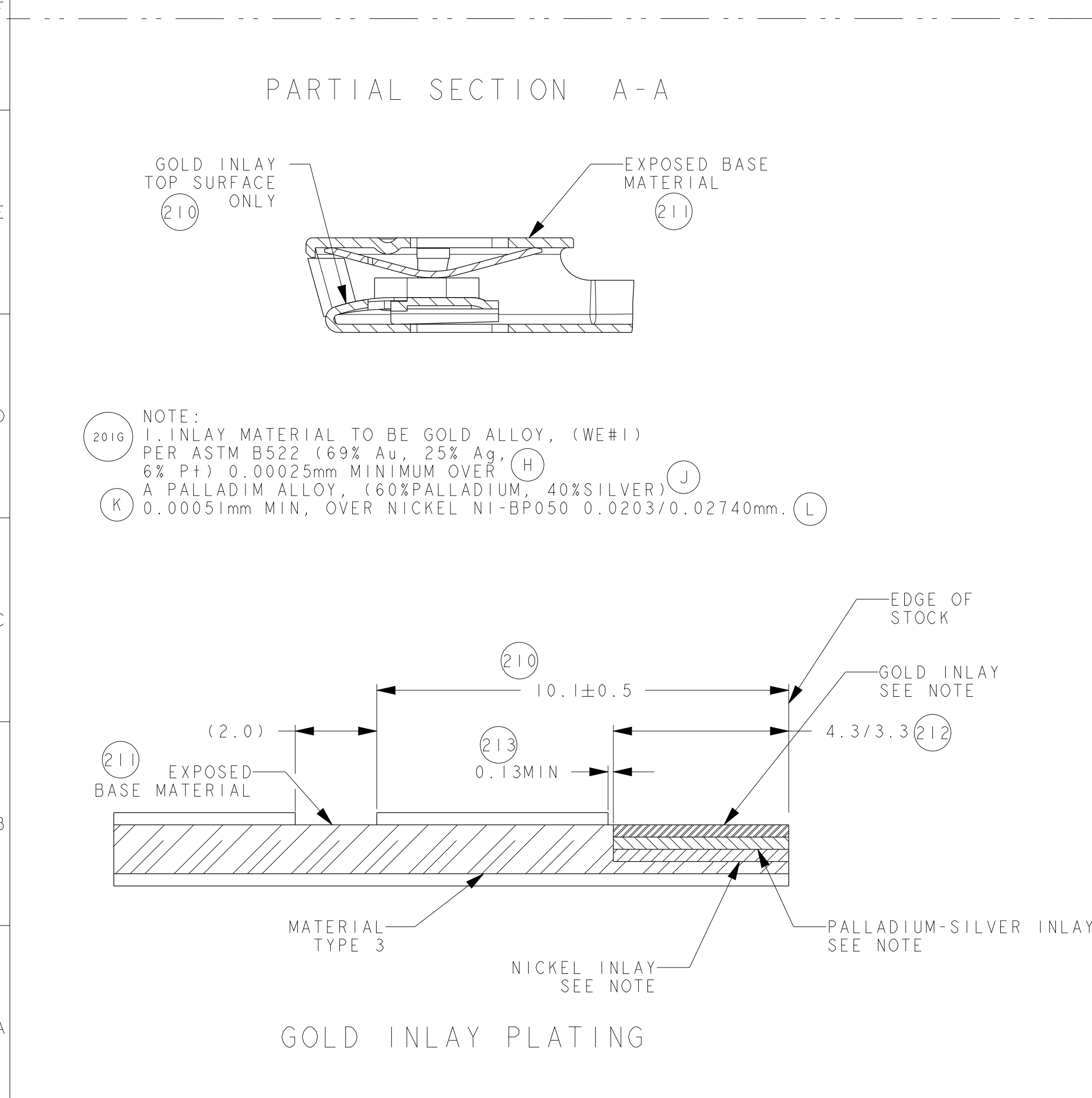
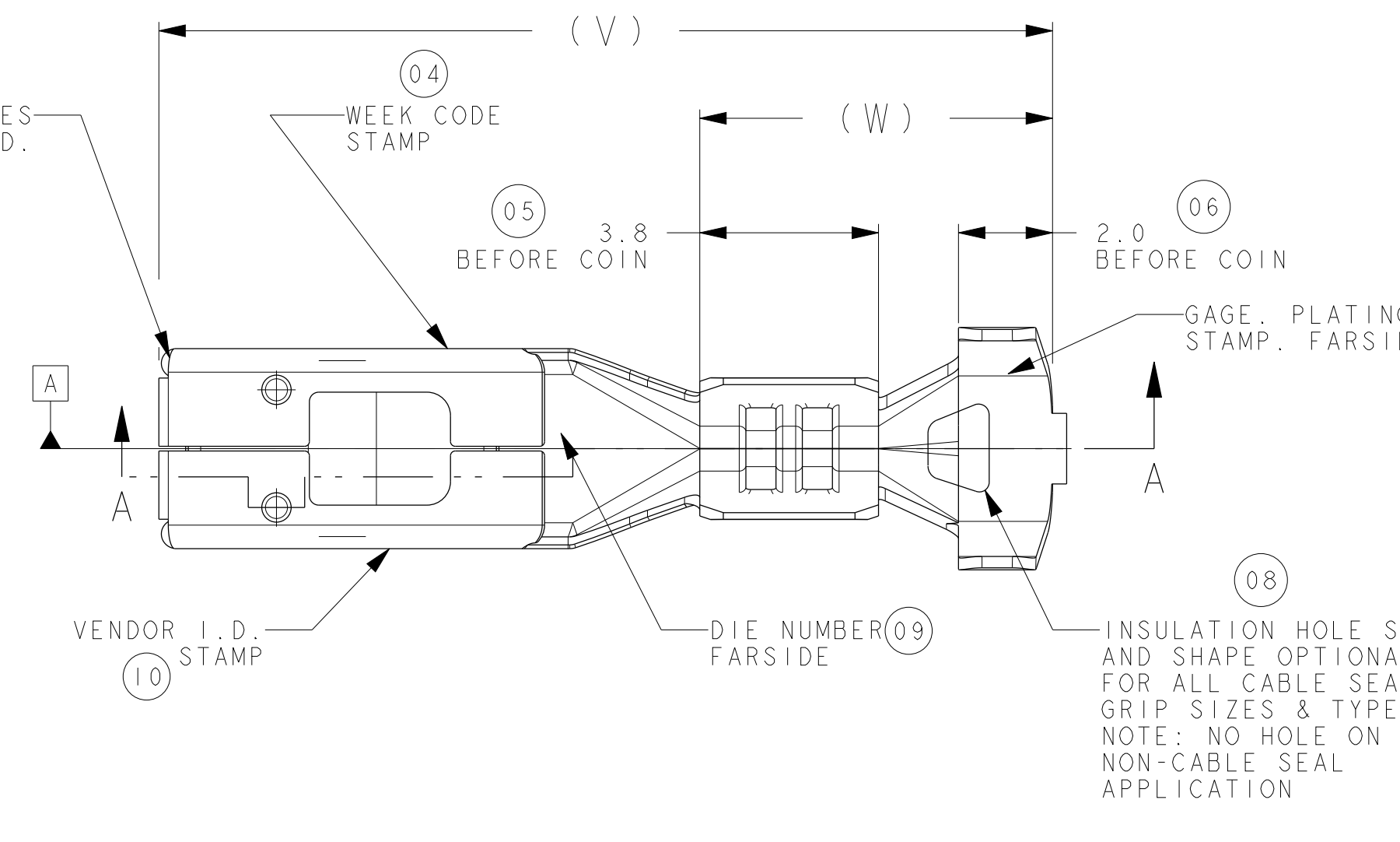
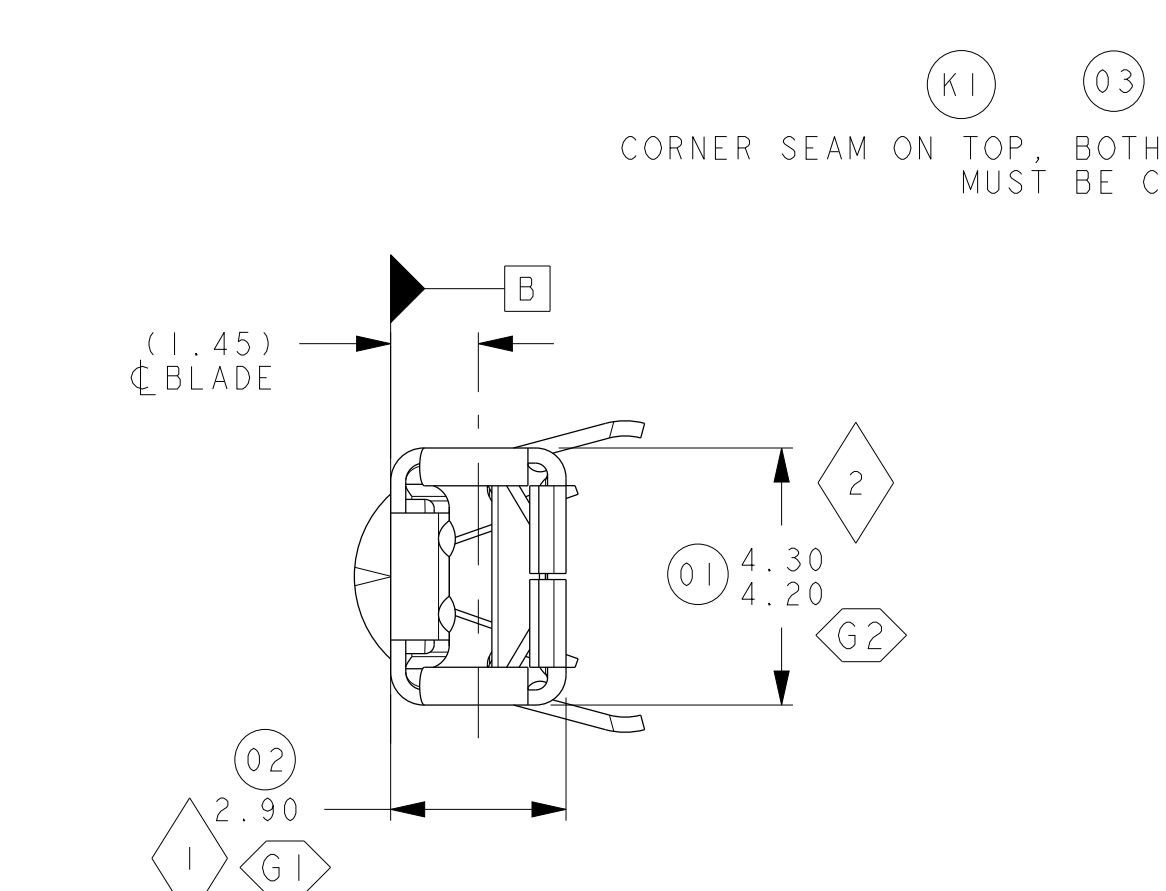
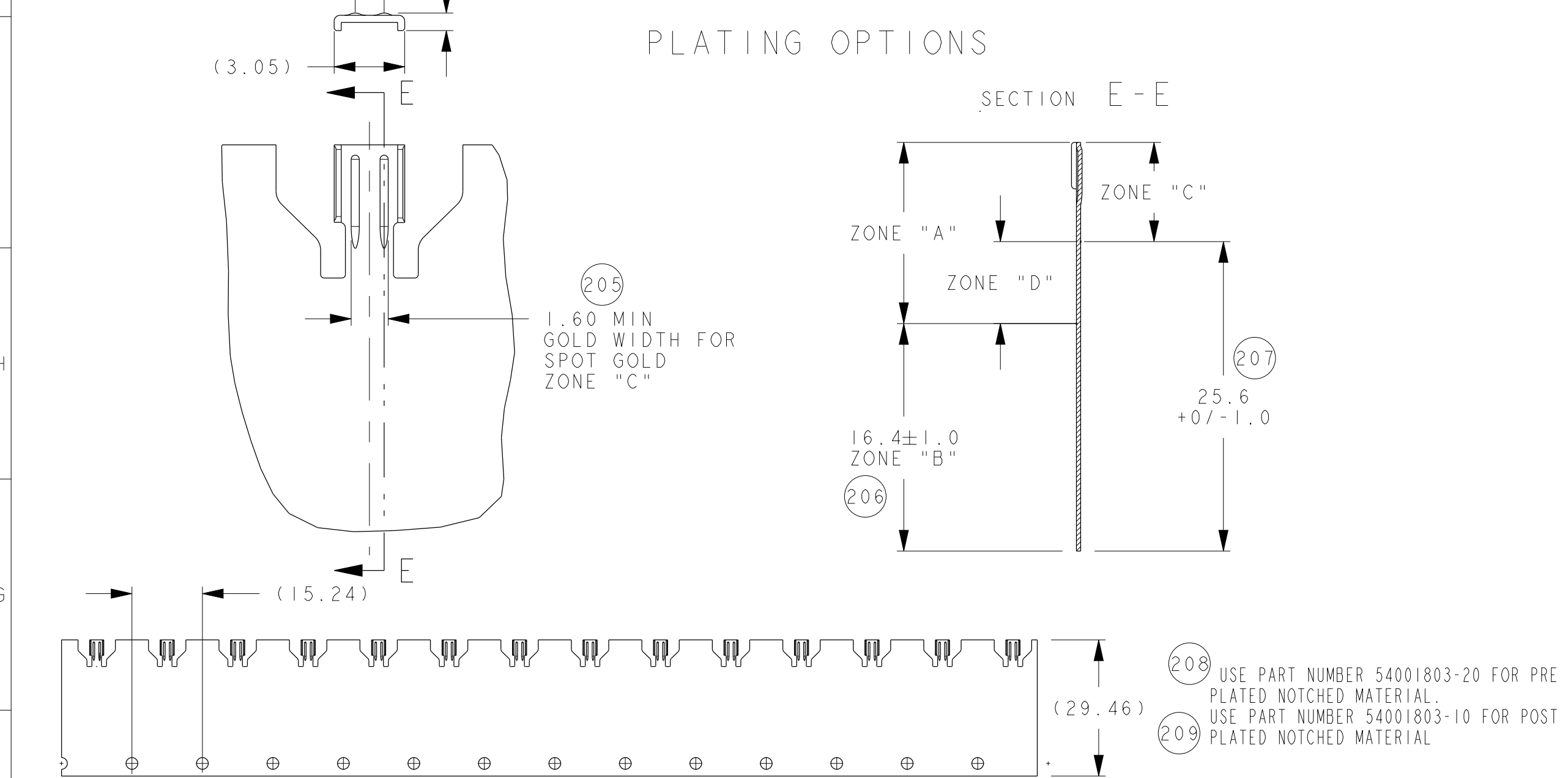

REV	DATE	BY	CHKD	DESCRIPTION
1	10/12	2		
2	14/16	2		
3	18/20	7		
4	2(18/20)	9		
5	22	5		
6	22	5		

LAST INSPECTION BALLOON NUMBER: 1-49: 17, 50-99: 74, 100-199: 105, 200-299: 213