

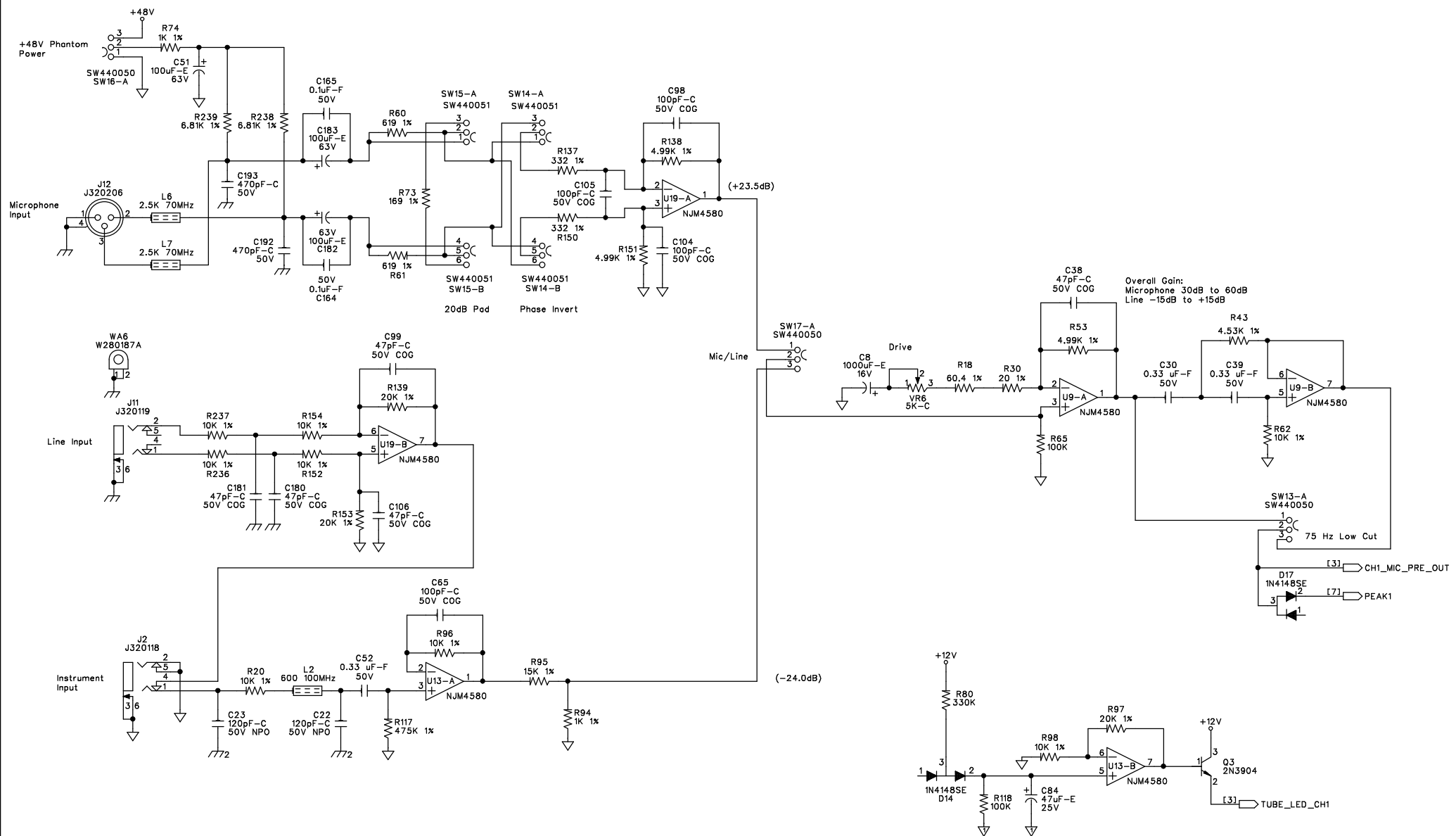

Channel 1



SIZE: A	SHEET TITLE: Channel 1 Input/Gain	REVISION: B2
START DATE: 07-01-10	DRAWING NO: 05-0098	SHEET: 2 OF 10

Channel 1

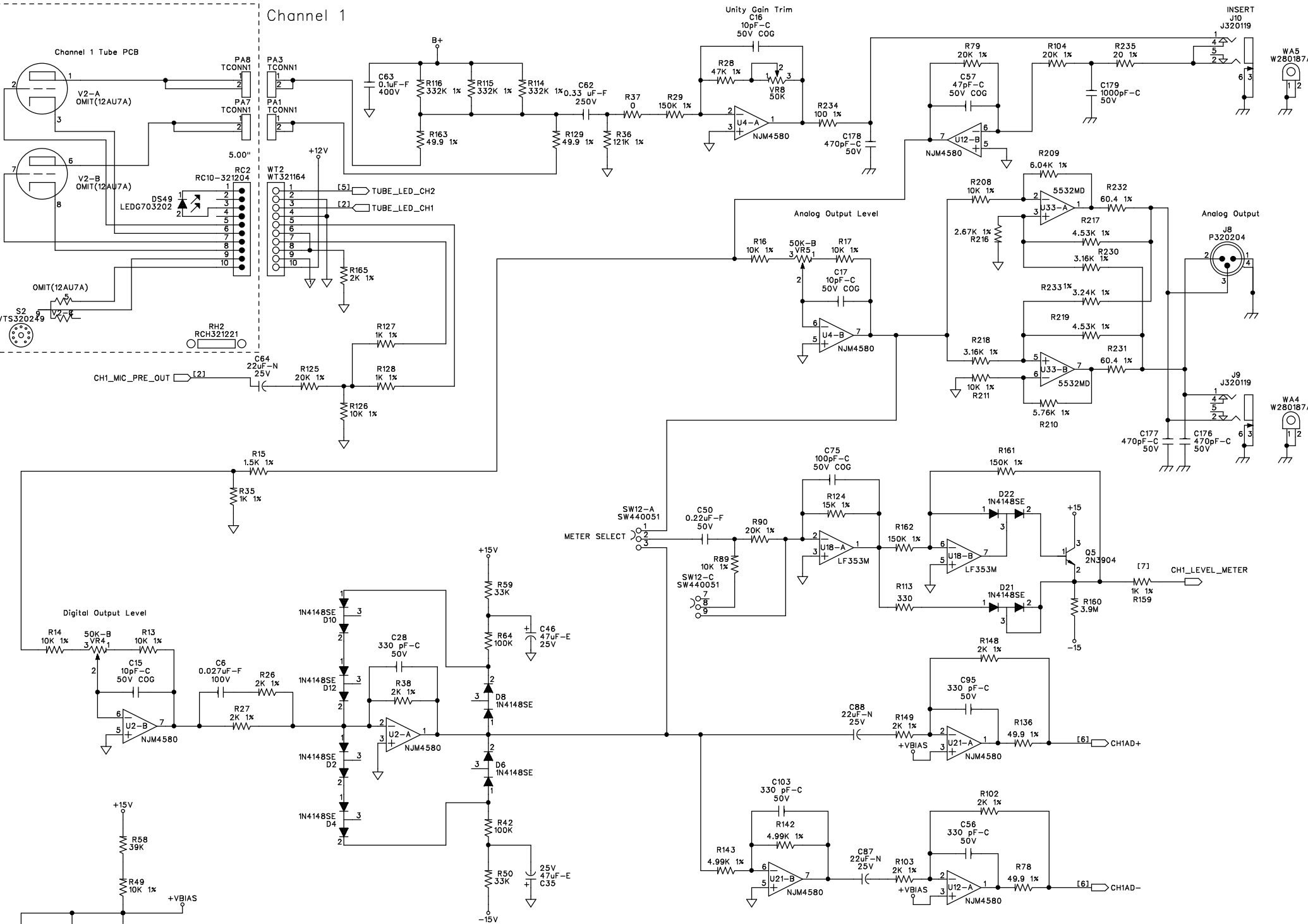

SIZE: A	SHEET TITLE: Channel 1 Tube/Level	REVISION: B2
START DATE: 07-01-10	DRAWING NO: 05-0098	SHEET: 3 OF 10

Channel 2

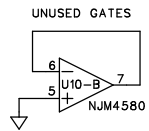
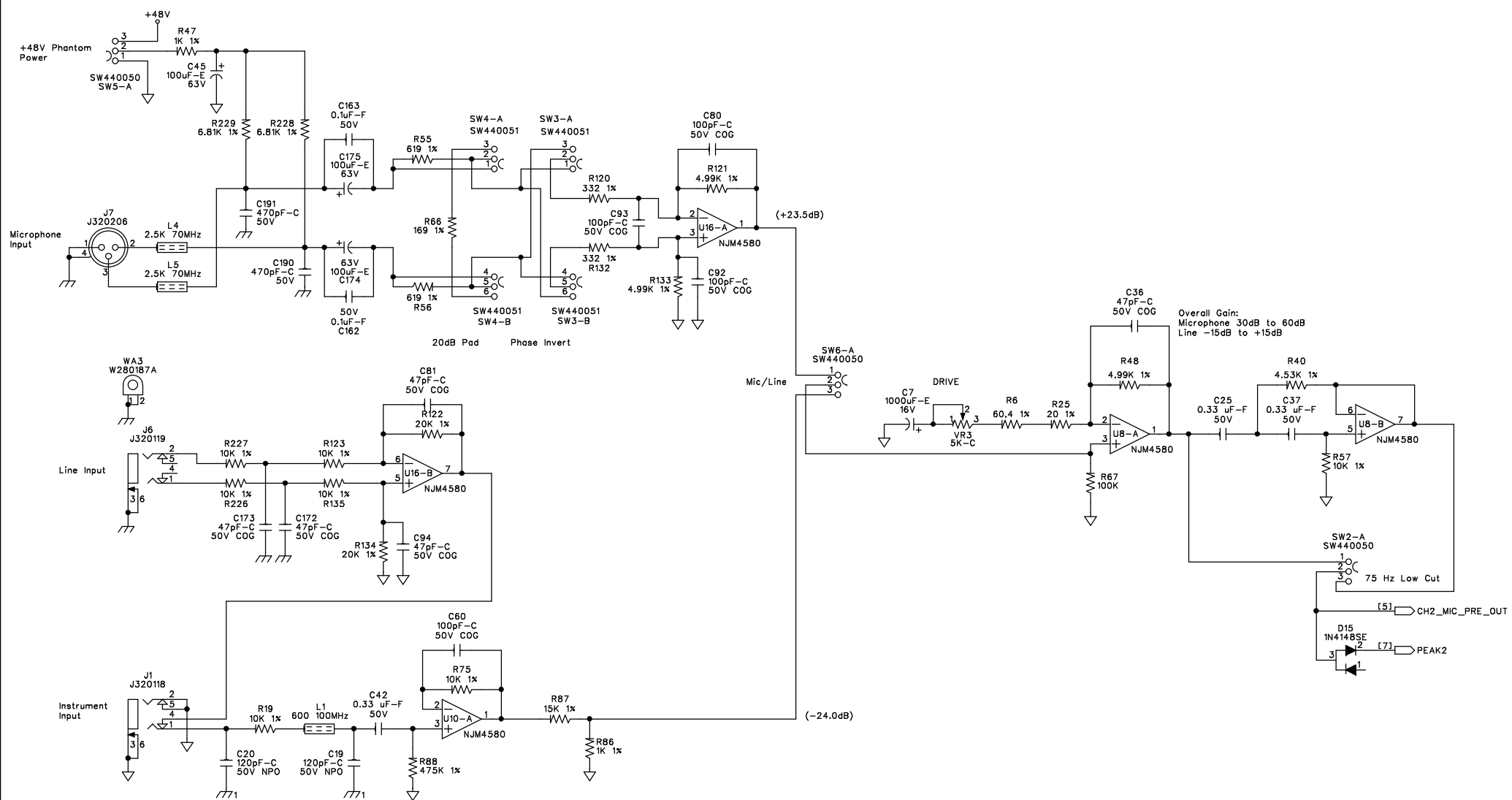

SIZE: A	SHEET TITLE: Channel 2 Input/Gain	REVISION: B2
START DATE: 07-01-10	DRAWING NO: 05-0098	SHEET: 4 OF 10

Channel 2

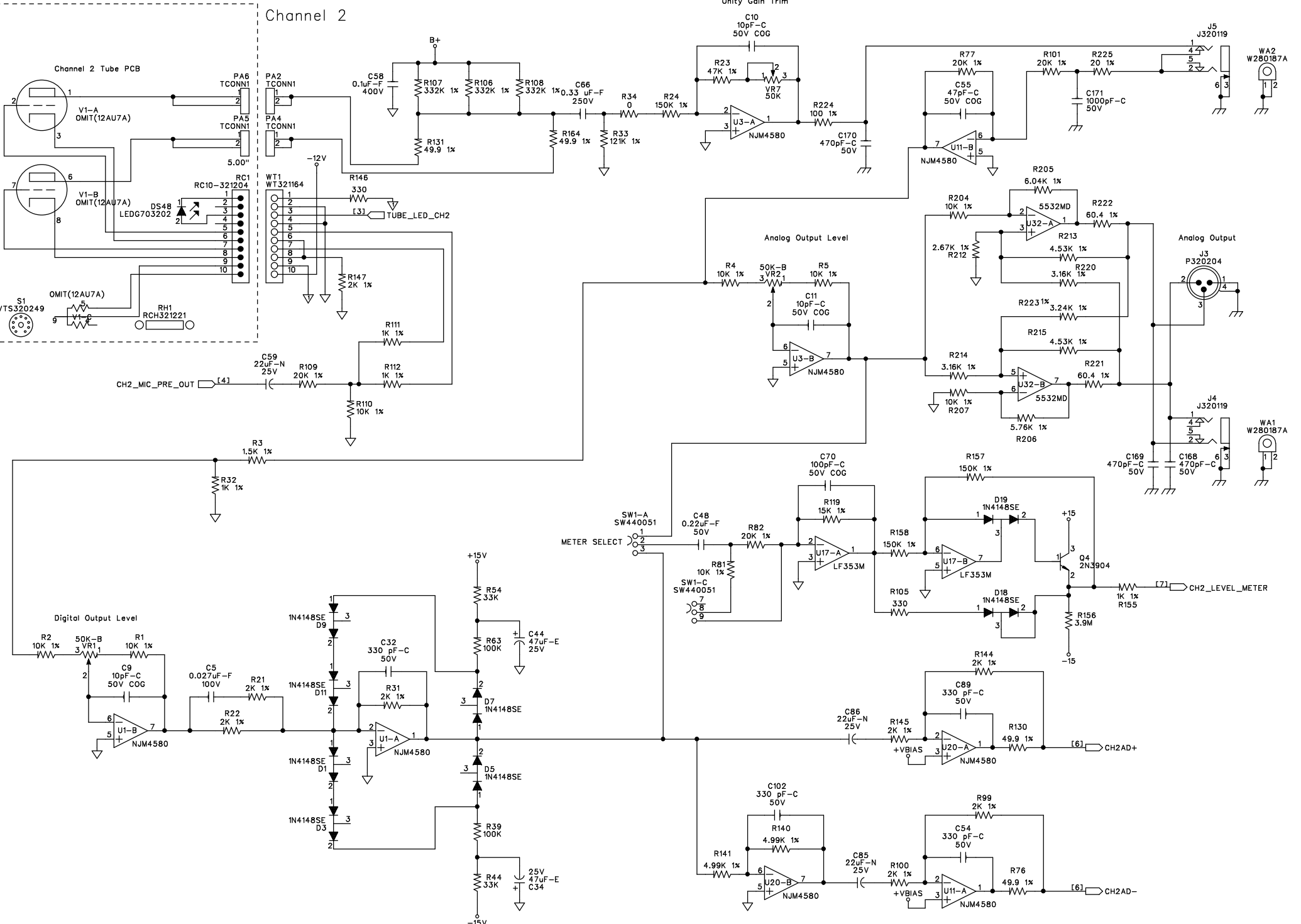

SIZE: A	SHEET TITLE: Channel 2 Tube/Level	REVISION: B2
START DATE: 07-01-10	DRAWING NO: 05-0098	SHEET: 5 OF 10

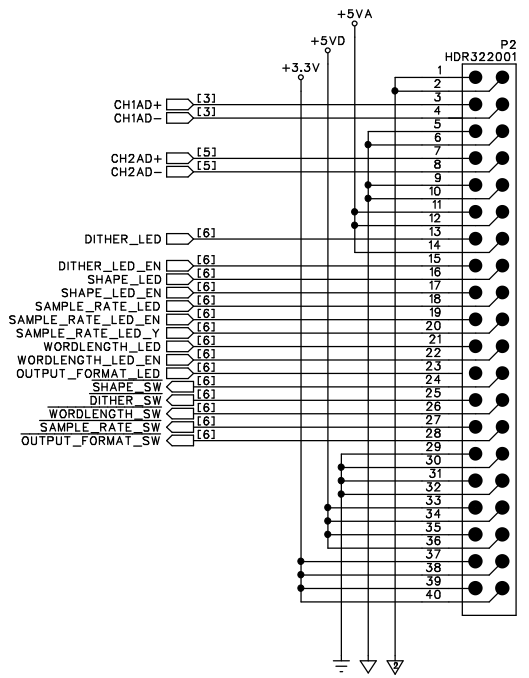
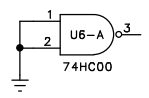
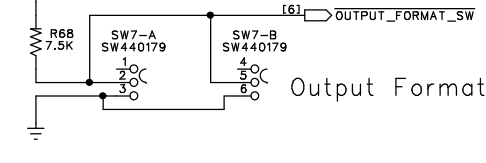
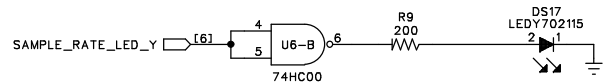
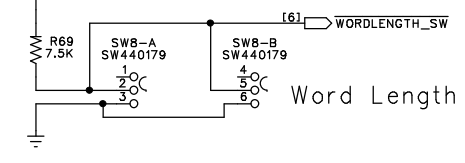
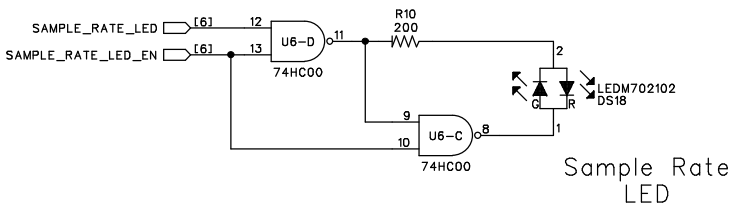
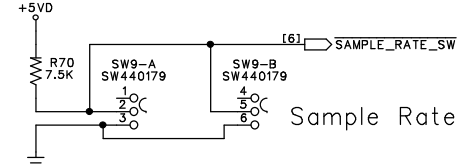
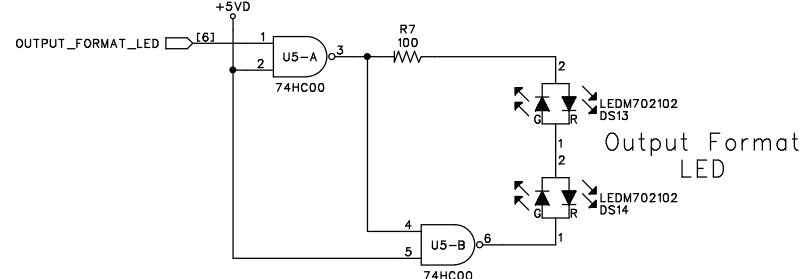
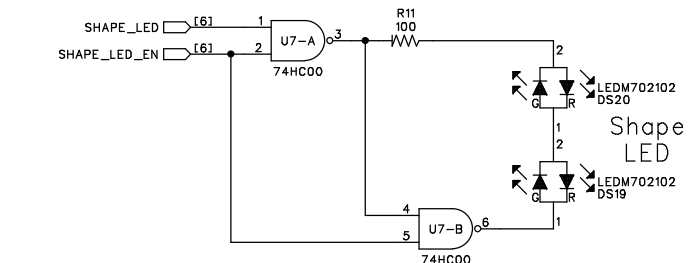
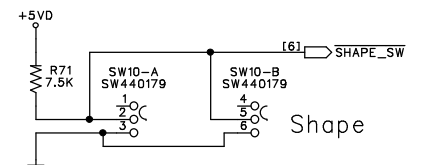
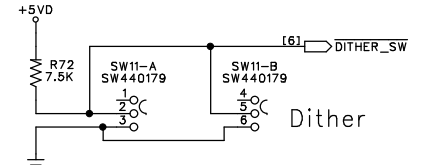
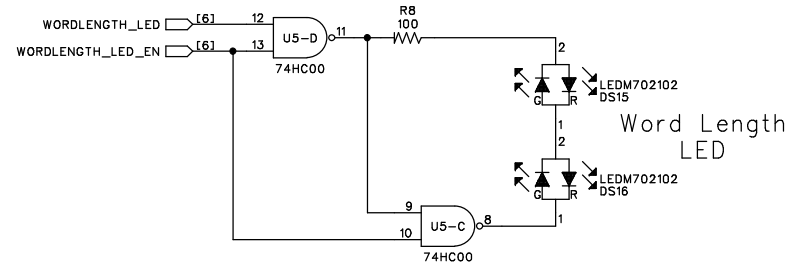
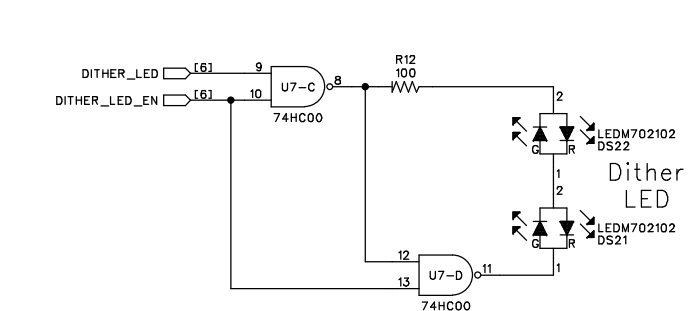

SIZE: A	SHEET TITLE: Digital Switches/Connector	REVISION: B2
START DATE: 07-01-10	DRAWING NO: 05-0098	SHEET: 6 OF 10

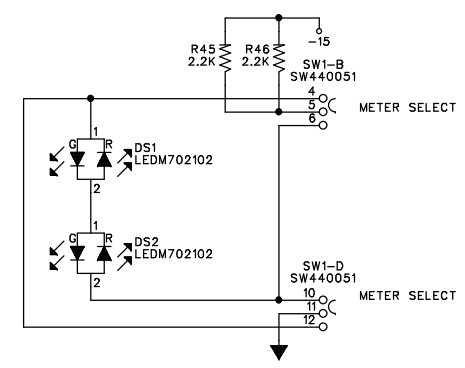
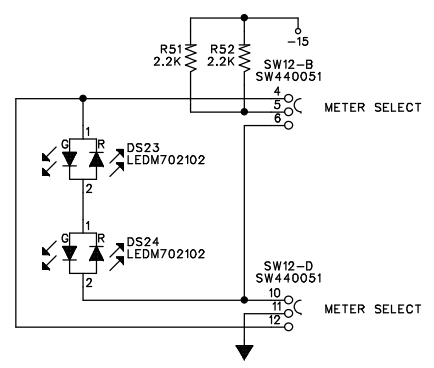
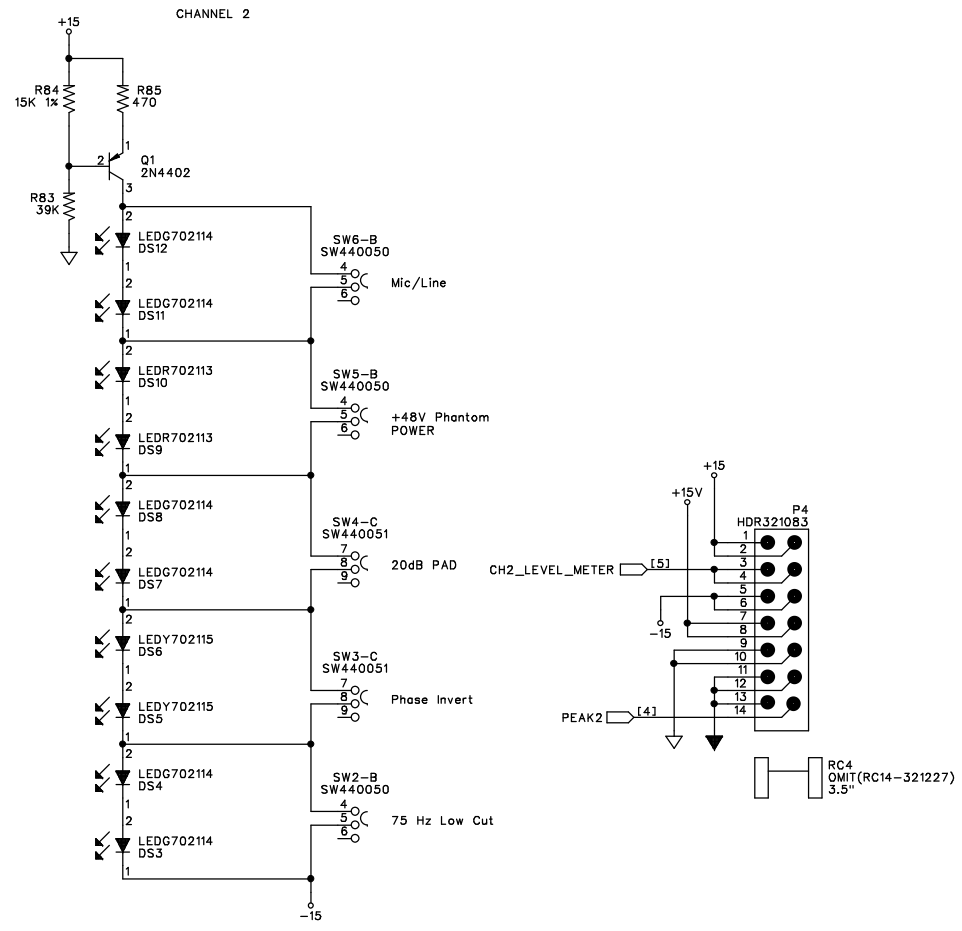
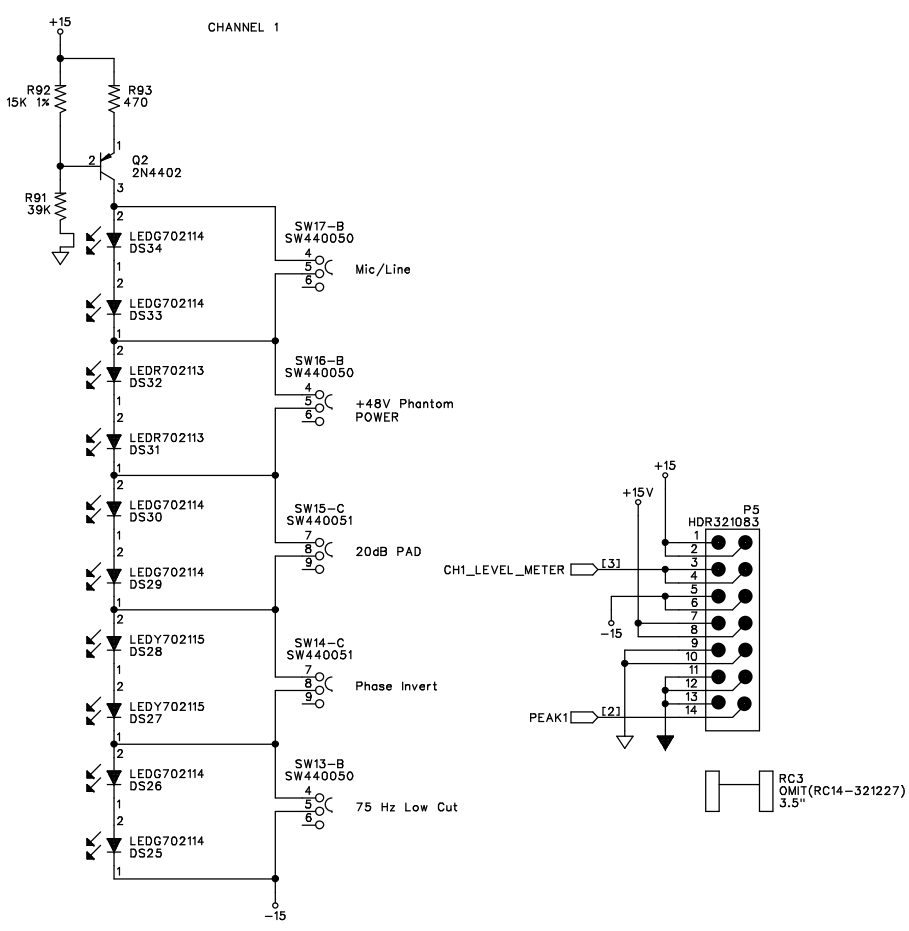

- UNUSED GATES
- SW15-D SW440051
  - SW3-D SW440051
  - SW14-D SW440051
  - SW4-D SW440051

SIZE: A	SHEET TITLE: Switches/Switches LED's	REVISION: B2
START DATE: 07-01-10	DRAWING NO: 05-0098	SHEET: 7 OF 10

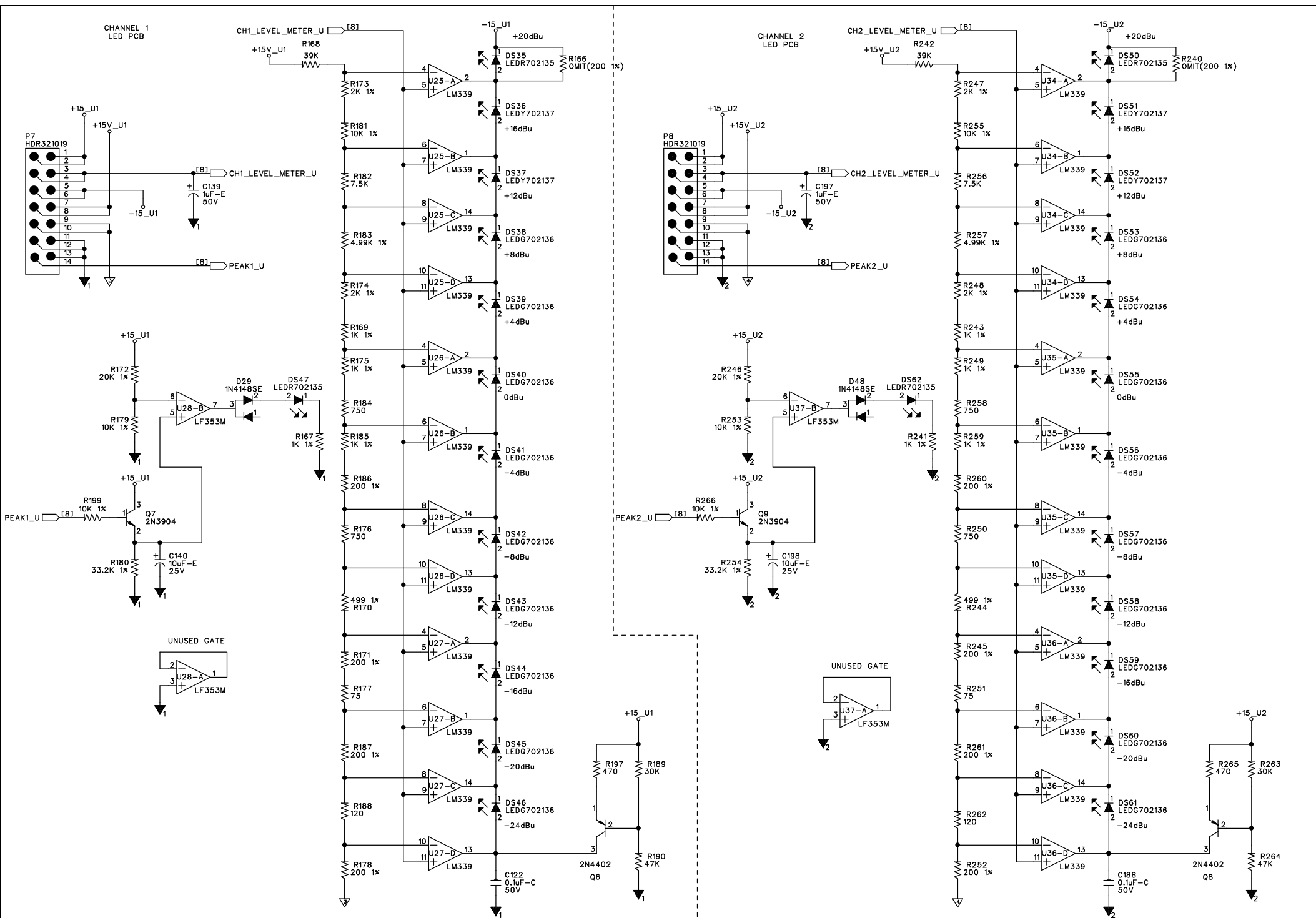

SIZE: A	SHEET TITLE: Channel 1 & Channel 2 LED PCB's	REVISION: B2
START DATE: 07-01-10	DRAWING NO: 05-0098	SHEET: 8 OF 10

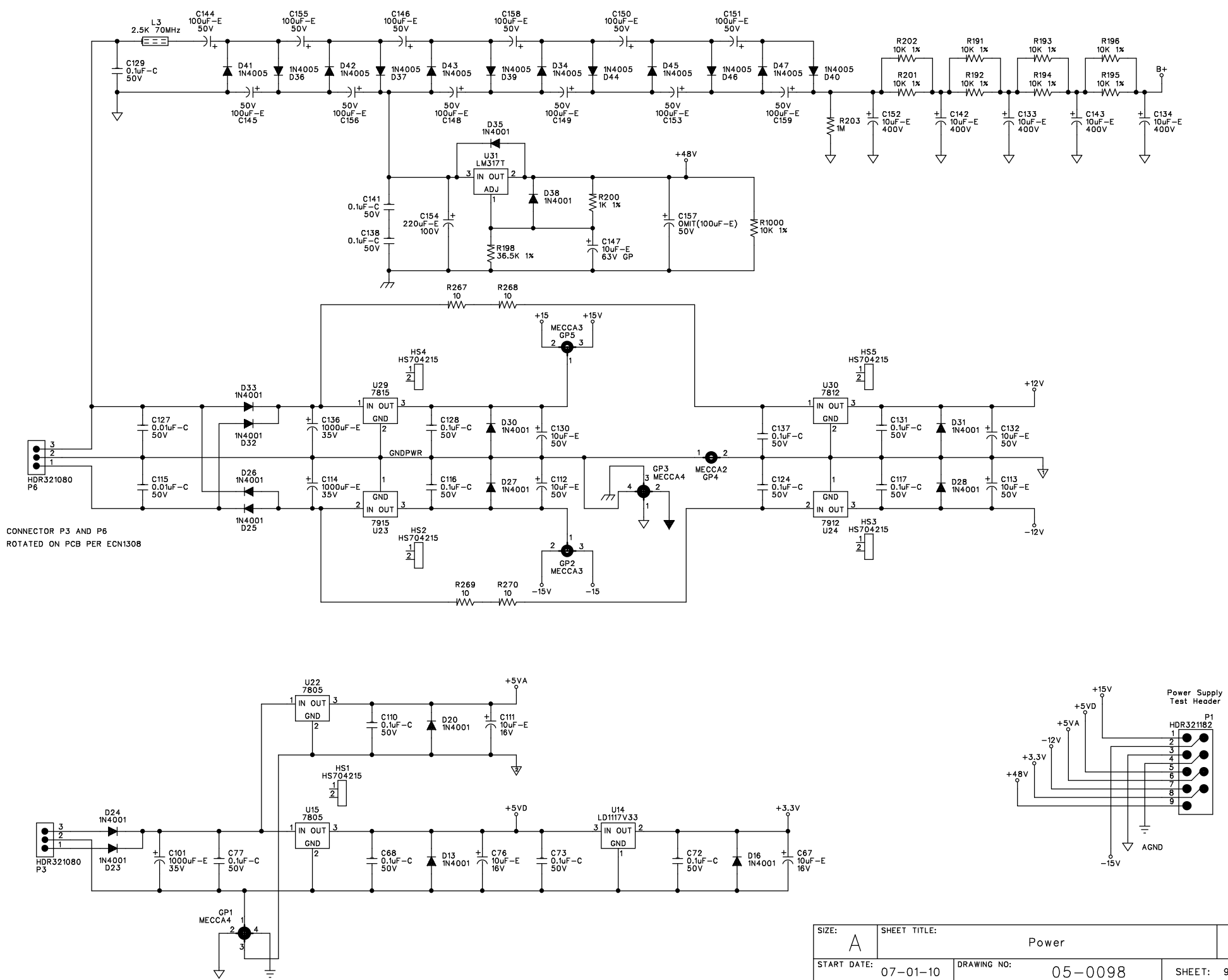

SIZE: A	SHEET TITLE: Power	REVISION: B2
START DATE: 07-01-10	DRAWING NO: 05-0098	SHEET: 9 OF 10



Bill Of Materials for 050098B2.sch on Thu Jul 01 17:33:10 2010

Qty	Reference	HMG#	Description	Audit	Schematic Part	PCB Decal
1	PCB1	80-0098-B	PCB, 80-0098-B, DUAL MIC PRE ANALOG PCB	PT1046	80XXXXYY	PCBNUL
30	A2-12 A14-15 A17-30 A32-34	NON-PART	NON-PART, PCB ONLY, BREAKOFF PART	PT1481	BRKOFF	BRKOFF
2	C115 C127	62-3142	CAP, 0.01uF, CER, 50V, 10%, 0805, T&R	PT1118	C0.01UC50K0805	0805
2	C5-6	56-0033	CAP, 0.027uF, FILM, 100V, 5%, RFEF200, AMMO	PT1282	C0.027UF100JR	RFEF200
72	C1-4 C12-14 C18 C21 C24 C26 C29 C31 C33 C40-41 C43 C47 C49 C53 C61 C68-69 C71-74 C77-79 C82-83 C90-91 C96-97 C100 C107-110 C116-126 C128-129 C131 C135 C137-138 C141 C160-161 C166-167 C184-189 C194-196	62-3139	CAP 0.1uF CER 50V 20% Y5V 0805 TA	PT1087	C0.1UC50M0805	0805
2	C58 C63	56-2218	CAP, 0.1uF, FILM, 400V, 5%, RFNG400, BULK	PT1772	C0.1UF400JR	RFNG400
4	C162-165	56-0012	CAP, 0.1uF, FILM, 50V, 5%, RFEC200, AMMO	PT1200	C0.1UF50JR	RFEC200
2	C48 C50	56-0014	CAP, 0.22uF, FILM, 50V, 5%, RFED200, AMMO	PT1077	C0.22UF50JR	RFED200
2	C62 C66	62-3200	CAP 0.33uF FILM 250V 10% RAD TA	PT1844	C0.33UF250KR	RFQE490
6	C25 C30 C37 C39 C42 C52	56-0015	CAP, 0.33uF, FILM, 50V, 5%, RFEE200, AMMO	PT1104	C0.33UF50JR	RFEE200
2	C171 C179	62-3136	CAP 1000pF CER 50V 20% X7R 0805 TA	PT1109	C1000PC50M0805	0805
2	C7-8	60-0064	CAP, 1000uF, ELEC, 16V, 20%, LEAD LENGTH 5mm, REM200P, BULK	PT1334	C1000UE16MR	REM200P
3	C101 C114 C136	60-1073	CAP 1000uF ELEC 35V 20% 105C 13 X 25 BULK	PT1971	C1000UE35MR1	REQ200P
10	C60 C65 C70 C75 C80 C92-93 C98 C104-105	62-3503	CAP 100pF CER 50V 5% COG 0805 TA	PT1786	C100PC50J0805	0805
11	C144-146 C149-151 C153 C155-156 C158-159	60-1013	CAP, 100uF, ELEC, 50V, 20%, REJ200P, AMMO	PT1408	C100UE50MR	REJ200P
1	C148	60-0093	CAP 100uF ELEC 50V 20% 150C 8 X 11 TA	PT1510	C100UE50MR1	REM200P
1	C157	OMIT	OMIT CAP 100uF EL 50V 20% HT 8x11R 5LS TA (60-1013)	PT1409	C100UE50MRO	REJ200P
6	C45 C51 C174-175 C182-183	60-1034	CAP, 100uF, ELEC, 63V, 20%, REM200P, AMMO	PT1777	C100UE63MR	REM200P
6	C9-11 C15-17	62-3140	CAP 10pF CER 50V 5% COG 0805 TA	PT1088	C10PC50J0805	0805
4	C27 C67 C76 C111	60-0049-01	CAP, 10uF, ELEC, 16V, 20%, RED200P, AMMO	PT1080	C10UE16MR	RED200P
2	C140 C198	60-0050-01	CAP, 10uF, ELEC, 25V, 20%, RED200P, AMMO	PT1205	C10UE25MR	RED200P
5	C133-134 C142-143 C152	60-0310	CAP, 10uF, ELEC, 400V, 20%, REQ200P, AMMO	PT1444	C10UE400MR	REQ200P
4	C112-113 C130 C132	60-1074	CAP 10uF ELEC 50V 20% 105C 5 X 11 TA	PT1972	C10UE50MR1	REE200P
1	C147	60-0320	CAP 10uF EL 63V 20% GP 5x11R BK	PT3501	C10UE63MR1	REE200P
4	C19-20 C22-23	62-3135	CAP 120pF CER 50V 5% NPO 0805 TA	PT1440	C120PC50J0805	0805
2	C139 C197	60-0044-01	CAP, 1uF, ELEC, 50V, 20%, RED200P, AMMO	PT1079	C1UE50MR	RED200P
1	C154	60-0303	CAP 220uF ELEC 100V 20% 13X25 5LP BK	PT1842	C220UE100MR	REQ200P
6	C59 C64 C85-88	60-0402	CAP, 22uF, ELEC, NON-POL, 25V, 20%, REG200, AMMO	PT1084	C22UN25MR	REG200
8	C28 C32 C54 C56 C89 C95 C102-103	62-3131	CAP 330pF CER 50V 10% X7R 0805 TA	PT1284	C330PC50K0805	0805
10	C168-170 C176-178 C190-193	62-3133	CAP 470pF CER 50V 10% X7R 0805 TA	PT1086	C470PC50K0805	0805
12	C36 C38 C55 C57 C81 C94 C99 C106 C172-173 C180-181	62-3132	CAP 47pF CER 50V 5% COG 0805 TA	PT1085	C47PC50J0805	0805
5	C34-35 C44 C46 C84	60-0054-01	CAP 47uF EL 25V 20% GP 5x11R 5LS TA	PT2959	C47UE25MR1	REE200P
15	D13 D16 D20 D23-28 D30-33 D35 D38	70-0000	DIO, 1N4001, 50V, 1 AMP, RDB200, AMMO	PT1003	D1N4001-R	RDB200
12	D34 D36-37 D39-47	70-0017	DIO, 1N4005, 600V, 1 AMP, RDB200, AMMO	PT1455	D1N4005-R	RDB200
21	D1-12 D14-15 D17-19 D21-22 D29 D48	70-0113	DIO MMBD4148SE DUAL 75V 600mA SOT-23 CB	PT3957	D1N4148SE-S	SOT-23

2	A1 A31	NON-PART	NON-PART FIDUCIAL TARGET FOR AUTO INSERTION	PT2904	FIDUCIAL-AI	FIDUCIAL-AI
2	P7-8	32-1019	HDR, 14 PIN, 0.1" SPC, 2 X 7, R/A, MALE	PT1047	HDR321019	HC72H
2	P3 P6	32-1080	HDR, 3 PIN, 0.1" SPC, 1 X 3, LCK, R/A, MALE	PT1073	HDR321080	HC3L
2	P4-5	32-1083	HDR, 14 PIN, 0.1" SPC, 2 X 7, VERT, MALE	PT1074	HDR321083	HC72
1	P1	32-1182	HDR, 9 PIN, 0.1" SPC, 1 X 5, PIN 10 MISSING, VERT, MALE	PT1120	HDR321182	HDR321182
1	P2	32-2001	HDR, 40 PIN, 0.1" SPC, 2 X 20, 0.025" SQ PIN, VERT, MALE	PT1794	HDR322001	HC202M
5	HS1-5	70-4215	HEATSINK, TO-220, VERT	PT1339	HS704215	HS704215
2	J1-2	32-0118	CON, JACK, 1/4 PHONO, PLAIN NOSE THREAD, SLIMLINE	PT1792	J320118	J320118
6	J4-6 J9-11	32-0119	CON, JACK, 1/4 PHONO, FULL NOSE THREAD, SLIMLINE	PT1359	J320119	J320119
2	J7 J12	32-0206	CON, JACK, XLR, R/A, PCA A SERIES	PT1219	J320206	XLRF-1
1	LBL1	30-0121	LABEL BARCODE AUTOINSERTABLE RAW	PT2790	LABEL300121	LABEL300121
2	DS48-49	70-3202	LED, AMBER, T1, W/.450 MOLDED SPACER	PT1861	LEDA703202	RLC100
12	DS3-4 DS7-8 DS11-12	70-2114	LED, GRN, T1, RLC100, AMMO	PT1059	LEDG702114	RLC100
	DS25-26 DS29-30					
	DS33-34					
18	DS38-46 DS53-61	70-2136	LED, GRN, D1206, T&R	PT1296	LEDG702136	D1206
13	DS1-2 DS13-16	70-2102	LED, MULTI-COLOR, RED/GRN,T1, RADIAL, T&R	PT1860	LEDM702102	RLC100
	DS18-24					
4	DS9-10 DS31-32	70-2113	LED, RED, T1, RADIAL, AMMO	PT1058	LEDR702113	RLC100
4	DS35 DS47 DS50 DS62	70-2135	LED, RED, D1206, T&R	PT1295	LEDR702135	D1206
5	DS5-6 DS17 DS27-28	70-2115	LED, YEL, T1, RADIAL, AMMO	PT1060	LEDY702115	RLC100
4	DS36-37 DS51-52	70-2137	LED, YEL, D1206, T&R	PT1297	LEDY702137	D1206
5	L3-7	26-0217	IND, FERRITE BEAD, 2.5K OHM @ 70MHz, 0805, T&R	PT1261	LFB260217	0805
2	L1-2	26-0219	INDUCTOR, FERRITE BEAD, 600 OHM @ 100MHz, 0805, T&R	PT1453	LFB260219	0805
1	GP4	NON-PART	NON-PART MECCA GND/PWR TIE POINT 2 POS	PT2970	MECCA2	MECCA2
2	GP2 GP5	NON-PART	NON-PART MECCA GND/PWR TIE POINT 3 POS	PT2481	MECCA3	MECCA3
2	GP1 GP3	NON-PART	NON-PART MECCA GND/PWR TIE POINT 4 POS	PT2482	MECCA4	MECCA4
34	MH8-9 MH14-15	NON-PART	NON-PART, MOUNTING HOLE, .047 DIA., NON-PLATED	PT1863	MH047	MH047
	MH21-50					
12	MH1-2 MH4-5 MH7	NON-PART	NON-PART MOUNTING HOLE 0.156" NON-PLATED #6	PT3000	MH156	MH156
	MH10-13 MH17-19					
2	MH16 MH20	NON-PART	NON-PART TOOLING PIN HOLE 156MIL HOLE	PT2794	MH156-TOOL	MH156-TOOL
2	MH3 MH6	NON-PART	NON-PART MECHANICAL PLATED HOLE 300 PAD 156 HOLE #6	PT3001	MP300H156	MP300H156
2	J3 J8	32-0204	CON, PLUG, XLR, R/A, PCA A SERIES	PT1218	P320204	XLRM-1
5	Q3-5 Q7 Q9	70-1058	XSTR, 2N3904, NPN, SOT-23, T&R	PT1203	Q2N3904-S	SOT-23
4	Q1-2 Q6 Q8	70-1035	XSTR, 2N44402, PNP, SIGNAL, TO-92, AMMO	PT1527	Q2N4402	TO92(EBC)-V
2	R34 R37	50-1531	RES 0 5% 1/10W SM 0805 TA	PT1099	R0-C5-0805	0805
2	R3 R15	52-3208	RES 1.5K 1% 1/10W SM 0805 TA	PT1733	R1.5KC1-0805	0805
2	R224 R234	52-3235	RES 100 1% 1/10W SM 0805 TA	PT1706	R100-C1-0805	0805
4	R7-8 R11-12	50-1515	RES 100 5% 1/10W SM 0805 TA	PT1018	R100-C5-0805	0805
7	R39 R42 R63-65 R67	50-1504	RES 100K 5% 1/10W SM 0805 TA	PT1096	R100KC5-0805	0805
	R118					
4	R267-270	50-0057	RES 10 5% 1W SM 2512 TA	PT1866	R10-G5-2512	2512
47	R1-2 R4-5 R13-14	52-4500	RES 10K 1% 1/10W SM 0805 TA	PT1034	R10KC1-0805	0805
	R16-17 R19-20 R41					
	R49 R57 R62 R75 R81					
	R89 R96 R98 R110					
	R123 R126 R135 R152					
	R154 R179 R181					
	R191-196 R199					
	R201-202 R204					
	R207-208 R211					
	R226-227 R236-237					
	R253 R255 R266					
1	R1000	52-0107	RES 10K 1% 1/4W MF AR TA	PT1161	R10KE1-A	AR400
2	R188 R262	50-1534	RES 120 5% 1/10W SM 0805 TA	PT1367	R120-C5-0805	0805
2	R33 R36	52-3228	RES 121K 1% 1/10W SM 0805 TA	PT1713	R121KC1-0805	0805
6	R24 R29 R157-158	52-3226	RES 150K 1% 1/10W SM 0805 TA	PT1715	R150KC1-0805	0805
	R161-162					
6	R84 R87 R92 R95	52-3233	RES 15K 1% 1/10W SM 0805 TA	PT1708	R15KC1-0805	0805
	R119 R124					
2	R66 R73	52-3225	RES 169 1% 1/10W SM 0805 TA	PT1716	R169-C1-0805	0805
21	R32 R35 R47 R74 R86	52-4505	RES 1K 1% 1/10W SM 0805 TA	PT1037	R1KC1-0805	0805

	R94 R111-112							
	R127-128 R155 R159							
	R167 R169 R175 R185							
	R200 R241 R243 R249							
	R259							
1	R203	50-1506	RES 1M 5% 1/10W SM 0805 TA		PT1011 R1MC5-0805	0805		
4	R45-46 R51-52	50-1529	RES 2.2K 5% 1/10W SM 0805 TA		PT1127 R2.2KC5-0805	0805		
2	R212 R216	52-4507	RES 2.67K 1% 1/10W SM 0805 TA		PT1039 R2.67KC1-0805	0805		
8	R171 R178 R186-187	52-3224	RES 200 1% 1/10W SM 0805 TA		PT1717 R200-C1-0805	0805		
	R245 R252 R260-261							
2	R166 R240	OMIT	OMIT RES 200 1% 1/10W SM 0805 TA (52-3224)		PT2735 R200-C1-08050	0805		
2	R9-10	50-1510	RES 200 5% 1/10W SM 0805 TA		PT1013 R200-C5-0805	0805		
4	R25 R30 R225 R235	52-3240	RES 20 1% 1/10W SM 0805 TA		PT1694 R20-C1-0805	0805		
15	R77 R79 R82 R90 R97	52-4501	RES 20K 1% 1/10W SM 0805 TA		PT1035 R20KC1-0805	0805		
	R101 R104 R109 R122							
	R125 R134 R139 R153							
	R172 R246							
20	R21-22 R26-27 R31	52-4506	RES 2K 1% 1/10W SM 0805 TA		PT1038 R2KC1-0805	0805		
	R38 R99-100							
	R102-103 R144-145							
	R147-149 R165							
	R173-174 R247-248							
4	R214 R218 R220 R230	52-4508	RES 3.16K 1% 1/10W SM 0805 TA		PT1129 R3.16KC1-0805	0805		
2	R223 R233	52-4509	RES 3.24K 1% 1/10W SM 0805 TA		PT1040 R3.24KC1-0805	0805		
2	R156 R160	50-1537	RES 3.9M 5% 1/10W SM 0805 TA		PT1585 R3.9MC5-0805	0805		
2	R189 R263	50-1538	RES 30K 5% 1/10W SM 0805 TA		PT1280 R30KC5-0805	0805		
2	R180 R254	52-3219	RES 33.2K 1% 1/10W SM 0805 TA		PT1722 R33.2KC1-0805	0805		
3	R105 R113 R146	50-1517	RES 330 5% 1/10W SM 0805 TA		PT1020 R330-C5-0805	0805		
1	R80	50-1519	RES 330K 5% 1/10W SM 0805 TA		PT1022 R330KC5-0805	0805		
4	R120 R132 R137 R150	52-3232	RES 332 1% 1/10W SM 0805 TA		PT1709 R332-C1-0805	0805		
6	R106-108 R114-116	52-3210	RES 332K 1% 1/10W SM 0805 TA		PT1731 R332KC1-0805	0805		
4	R44 R50 R54 R59	50-1512	RES 33K 5% 1/10W SM 0805 TA		PT1015 R33KC5-0805	0805		
1	R198	52-4492	RES 36.5K 1% 1/10W SM 0805 TA		PT2160 R36.5KC1-0805	0805		
5	R58 R83 R91 R168	50-1528	RES 39K 5% 1/10W SM 0805 TA		PT1028 R39KC5-0805	0805		
	R242							
6	R40 R43 R213 R215	52-4510	RES 4.53K 1% 1/10W SM 0805 TA		PT1130 R4.53KC1-0805	0805		
	R217 R219							
12	R48 R53 R121 R133	52-4511	RES 4.99K 1% 1/10W SM 0805 TA		PT1041 R4.99KC1-0805	0805		
	R138 R140-143 R151							
	R183 R257							
4	R85 R93 R197 R265	50-1518	RES 470 5% 1/10W SM 0805 TA		PT1021 R470-C5-0805	0805		
2	R88 R117	52-3214	RES 475K 1% 1/10W SM 0805 TA		PT1961 R475KC1-0805	0805		
2	R23 R28	52-3207	RES 47K 1% 1/10W SM 0805 TA		PT1734 R47KC1-0805	0805		
2	R190 R264	50-1502	RES 47K 5% 1/10W SM 0805 TA		PT1009 R47KC5-0805	0805		
8	R76 R78 R129-131	52-4502	RES 49.9 1% 1/10W SM 0805 TA		PT1036 R49.9-C1-0805	0805		
	R136 R163-164							
2	R170 R244	52-4504	RES 499 1% 1/10W SM 0805 TA		PT1102 R499-C1-0805	0805		
2	R206 R210	52-4512	RES 5.76K 1% 1/10W SM 0805 TA		PT1131 R5.76KC1-0805	0805		
2	R205 R209	52-4513	RES 6.04K 1% 1/10W SM 0805 TA		PT1132 R6.04KC1-0805	0805		
4	R228-229 R238-239	52-4515	RES 6.81K 1% 1/10W SM 0805 TA		PT1281 R6.81KC1-0805	0805		
6	R6 R18 R221-222	52-4503	RES 60.4 1% 1/10W SM 0805 TA		PT1128 R60.4-C1-0805	0805		
	R231-232							
4	R55-56 R60-61	52-3216	RES 619 1% 1/10W SM 0805 TA		PT1725 R619-C1-0805	0805		
7	R68-72 R182 R256	50-1521	RES 7.5K 5% 1/10W SM 0805 TA		PT1024 R7.5KC5-0805	0805		
4	R176 R184 R250 R258	50-1530	RES 750 5% 1/10W SM 0805 TA		PT1029 R750-C5-0805	0805		
2	R177 R251	50-1535	RES 75 5% 1/10W SM 0805 TA		PT1101 R75-C5-0805	0805		
2	RC1-2	32-1204	RIBBON CABLE, 10 COND., 2mm SPACING, 5" LONG		PT1560 RC10-321204	PA1X10-079-039		
2	RC3-4	OMIT	OMIT RBN CBL 14CND 2X7 0.1SPC 3.5" FM/FM (32-1227)		PT4329 RC14-321227-O	PCBNUL		
2	RH1-2	32-1221	RIBBON CABLE HOLDER, 10 PIN, 2mm PITCH		PT1604 RCH321221	RCH10-079		
6	SW2 SW5-6 SW13	44-0050	SWITCH, DPDT, MINI IN-OUT, 6 PIN, E-SWITCH		PT1256 SW440050	SW440050		
	SW16-17							
6	SW1 SW3-4 SW12	44-0051	SWITCH, 4PDT, MINI IN-OUT, 12 PIN, E-SWITCH		PT1257 SW440051	SW440051		
	SW14-15							

## 050098B2.pps

5	SW7-11	44-0179	SWITCH, DPDT, MINI IN-OUT, MOMENTARY, 6 PIN	PT1793 SW440179	SW440179
8	PA1-8	NON-PART	NON-PART, TCONN1, BD-TO-BD CON, SPC .067 ROUTE BETWEEN	PT1864 TCONN1	TCONN1-A
2	U32-33	72-1439	IC, 5532MD, DUAL BIPOLAR OPAMP, SO8-200	PT1306 U5532MD-S	SO8-200
3	U5-7	72-5418	IC, 74HC00, QUAD 2-INPUT NAND, SO14, T&R	PT1348 U74HC00-S	SO14
2	U15 U22	70-4014	V-REG, 7805, +5V, 1.5 AMP, TO-220	PT1591 U7805	TO220(IGO)-V
1	U30	70-4013	V-REG, 7812, +12V, 1 AMP, TO-220	PT1646 U7812	TO220(IGO)-V
1	U29	70-4123	V-REG, 7815, +15V, 1 AMP, TO-220	PT1592 U7815	TO220(IGO)-V
1	U24	70-4017	V-REG, 7912, -12V, 1 AMP, TO-220	PT1654 U7912	TO220(GIO)-V
1	U23	70-4124	V-REG, 7915, -15V, 1 AMP, TO-220	PT1594 U7915	TO220(GIO)-V
1	U14	70-4021	V-REG, LD1117V33, +3.3V, 0.8 AMP, TO-220, BULK	PT1795 ULD1117V33	TO220(GOI)-V
4	U17-18 U28 U37	72-4032	IC, LF353M, DUAL,WIDE BANDWIDTH JFET INPUT OPAMP, SO8	PT1252 ULF353M-S	SO8
1	U31	70-4007	V-REG, LM317T, ADJ REG, 1.5 AMP, TO-220	PT1785 ULM317T	TO220(AOI)-V
6	U25-27 U34-36	72-4034	IC, LM339, QUAD COMPARATOR, SO14, T&R	PT1048 ULM339-S	SO14
14	U1-4 U8-13 U16 U19-21	72-1480	IC, NJM4580, DUAL OP-AMP, SO8	PT1374 UNJM4580-S	SO8
2	V1-2	OMIT	OMIT Tube 12AU7A Dual Triode Bulk (76-0167)	PT4330 V12AU7A-760167-O	VAC
4	VR1-2 VR4-5	40-2138	POT, 50K, B, 16mm, ROT, 15mm D-SHAFT, 41-CLICK	PT1068 VR50K402138	VR16-15DH
2	VR7-8	42-0221	POT, 50K, TRIM, HORIZONTAL MNT, VERT ADJUST, AMMO	PT1119 VR50K40221	VRTRIM1
2	VR3 VR6	40-2131	POT, 5K, C, 16mm, ROT, 15mm D-SHAFT, 41-CLICK	PT1797 VR5K402131	VR16-15DH
2	S1-2	32-0249	SOCKET TUBE 9 PIN W/LED COUNTERSINK	PT2005 VTS320249	VTS
6	WA1-6	28-0187-A	WASHER, GROUNDING FOR 32-0118/32-0119	PT1361 WA280187A	WA280187A
2	WT1-2	32-1164	CON, WIRE TRAP CONNECTOR, 10 POS, 2mm	PT1613 WT321164	WT321164



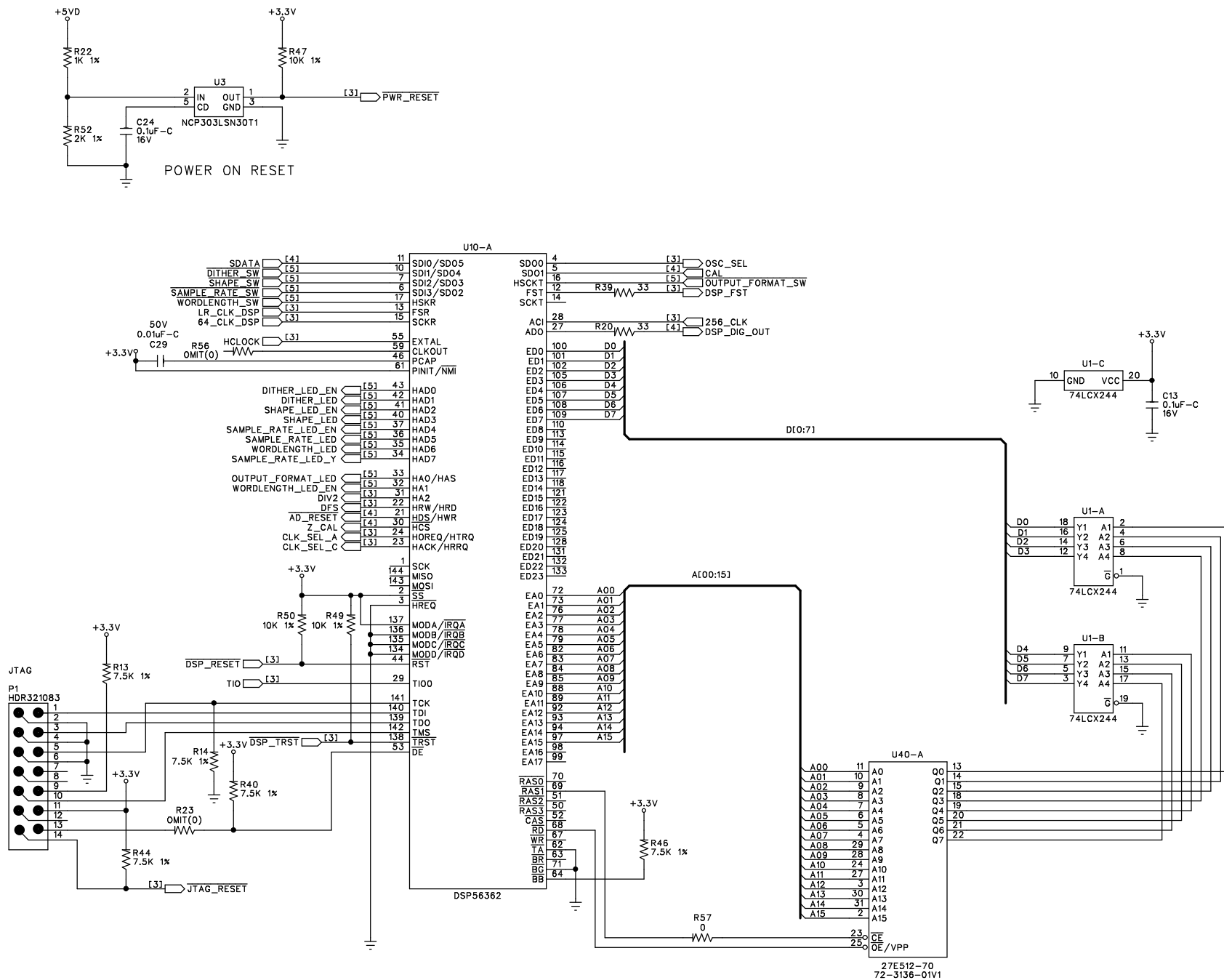

SIZE: A	SHEET TITLE: DSP	REVISION: E1
DATE: 06-17-10	DRAWING NO: 05-0099	SHEET: 2 OF 5



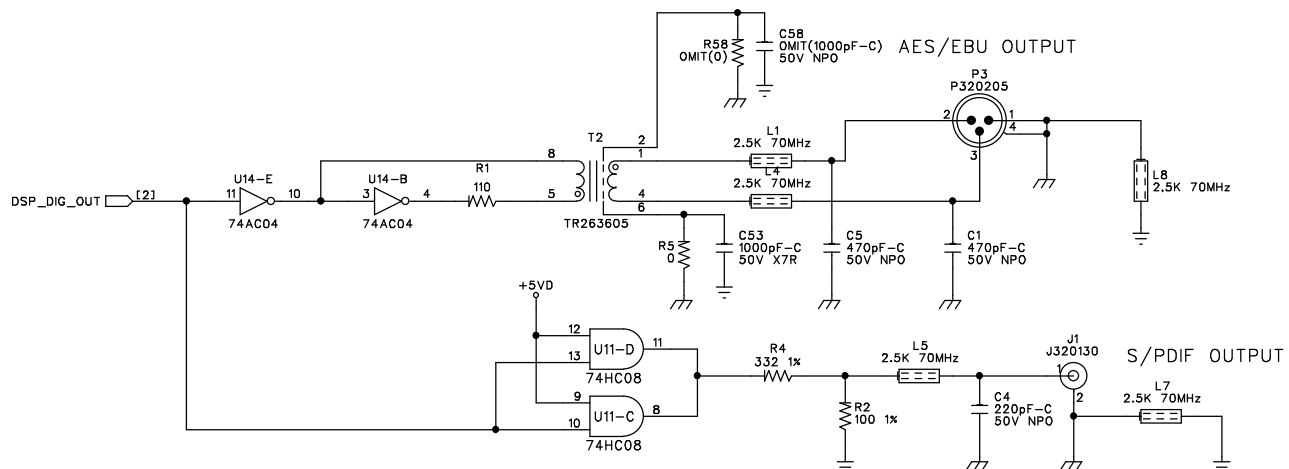
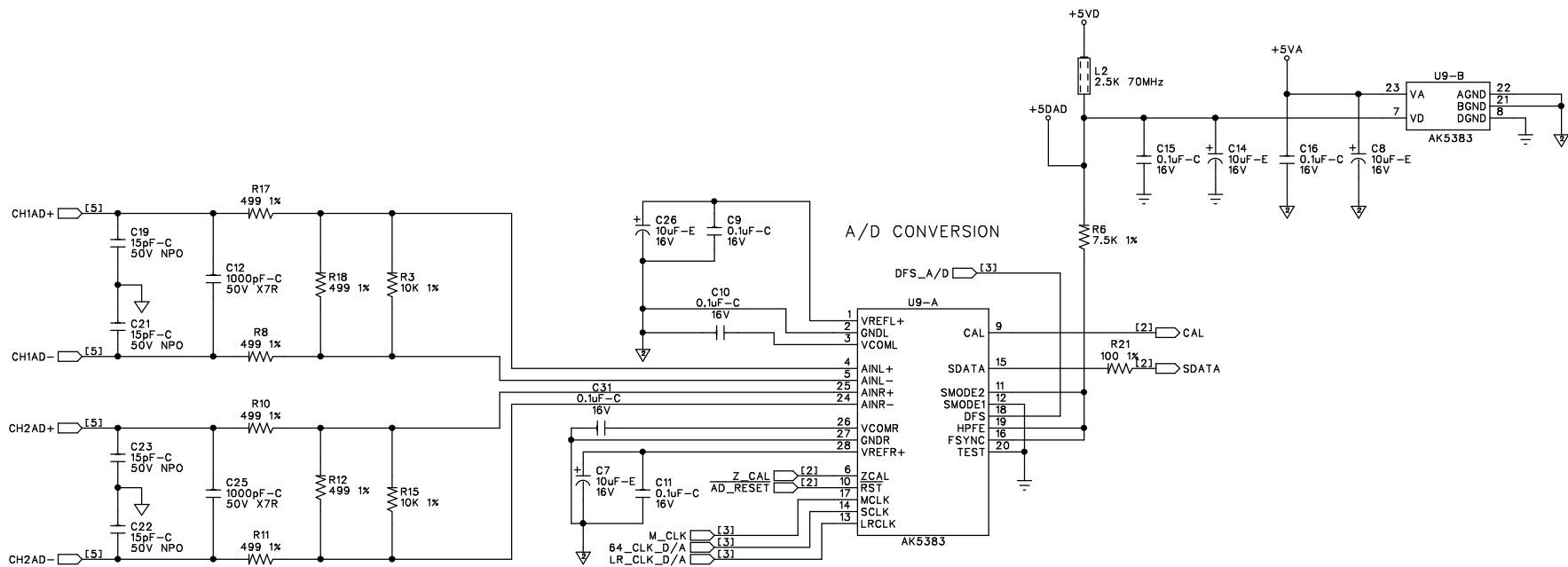

SIZE: A	SHEET TITLE: A/D & DIGITAL OUTPUT	REVISION: E1
DATE: 06-17-10	DRAWING NO: 05-0099	SHEET: 4 OF 5

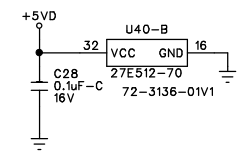
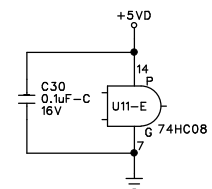
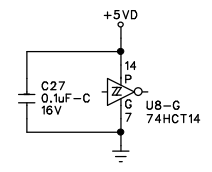
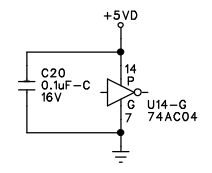
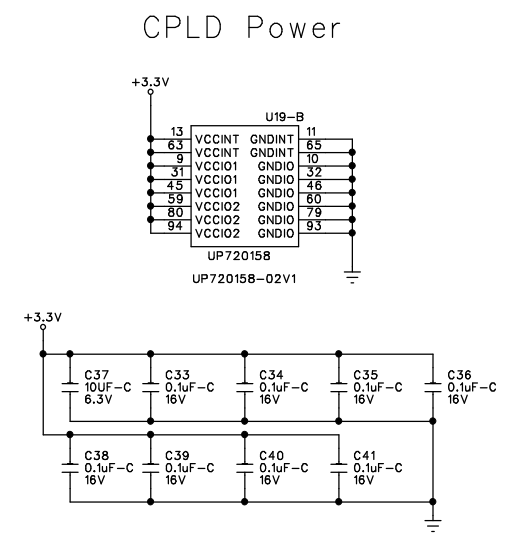
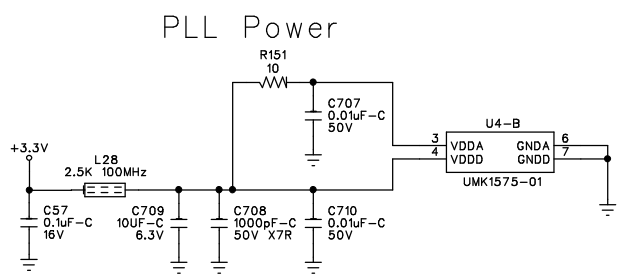
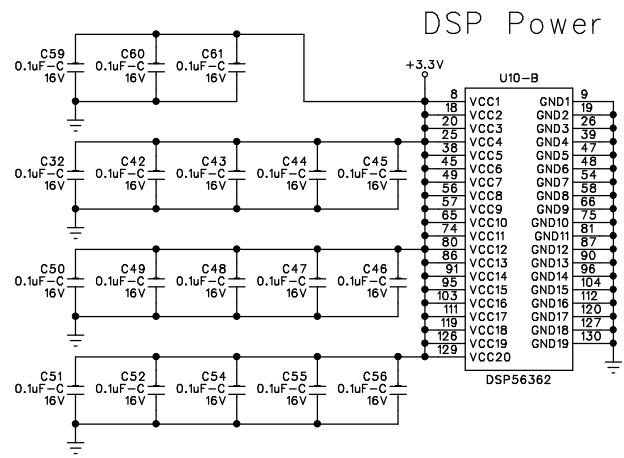
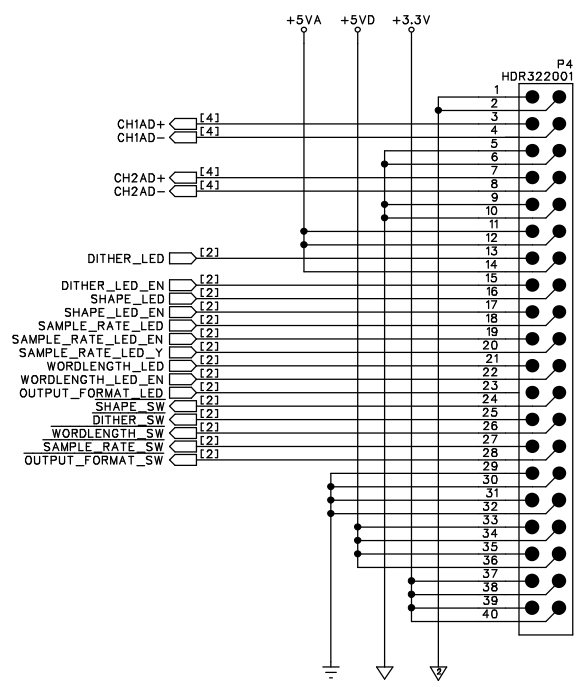
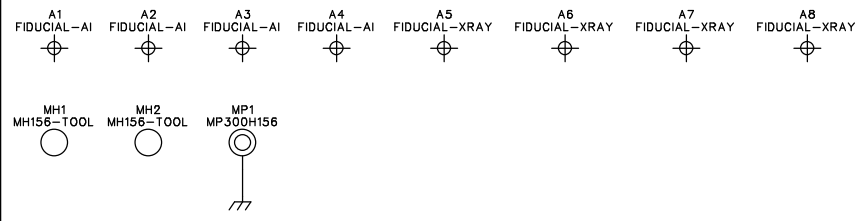

SIZE: A	SHEET TITLE: Power Gates	REVISION: E1
DATE: 06-17-10	DRAWING NO: 05-0099	SHEET: 5 OF 5

Bill Of Materials for 050099E1.sch on Thu Jun 17 13:56:29 2010

Qty	Reference	HMG#	Description	Audit	Schematic Part	PCB Decal
1	PCB1	80-0099	PCB 80-0099 DUAL MIC PRE DIGITAL PCB	PT2044	80XXXXXX	BARCODE
1	C693	56-0004	CAP 0.0047uF FILM PTR 100V 5% RF TA	PT1201	C0.0047UF100JR	RFDC200
1	C29	62-3142	CAP, 0.01uF, CER, 50V, 10%, 0805, T&R	PT1118	C0.01UC50K0805	0805
2	C707 C710	62-1311	CAP 0.01uF CER 50V 20% Y5V 0603 TA	PT2665	C0.01UC50M0603	0603
42	C6 C9-11 C13 C15-18 C20 C24 C27-28 C30-36 C38-52 C54-57 C59-61	62-1310	CAP 0.1uF CER 16V 20% Y5V 0603 TA	PT2696	C0.1UC16M0603	0603
1	C692	56-0012	CAP 0.1uF FILM MTPT 50V 5% RF TA	PT1200	C0.1UF50JR	RFEC200
1	C58	OMIT	OMIT CAP 1000pF CER 50V 5% NP0 0805 TA (62-3149)	PT2949	C1000PC50J0805O	0805
4	C12 C25 C53 C708	62-0110	CAP 1000pF CER 50V 10% X7R 0603 TA	PT3122	C1000PC50K0603	0603
2	C37 C709	62-3130	CAP 10uF CER 6.3V 10% X5R 0805 TA	PT3097	C10UC6.3K0805	0805
4	C7-8 C14 C26	60-1063	CAP 10uF EL 16V 20% GP 4X5.5 SM TA	PT3218	C10UE16M4X5.5S	CAP4X5.4
4	C19 C21-23	62-1300	CAP 15pF CER 50V 5% NPO 0603 TA	PT2659	C15PC50J0603	0603
1	C4	62-1313	CAP 220pF CER 50V 5% NPO 0603 TA	PT2923	C220PC50J0603	0603
2	C1 C5	62-1314	CAP 470pF CER 50V 5% NP0 0603 TA	PT2921	C470PC50J0603	0603
1	C3	62-1302	CAP 47pF CER 50V 5% NPO 0603 TA	PT2657	C47PC50J0603	0603
1	D7	70-0113	DIO, MMBD4148SE, DUAL DIODE, 75V, 600mA, SOT-23, T&R	PT1326	D1N4148SE-S	SOT-23
4	A1-4	NON-PART	NON-PART FIDUCIAL TARGET FOR AUTO INSERTION	PT2904	FIDUCIAL-AI	FIDUCIAL-AI
4	A5-8	NON-PART	NON-PART FIDUCIAL TARGET FOR XRAY	PT2905	FIDUCIAL-XRAY	FIDUCIAL-XRAY
1	P2	32-1079	HDR, 4 PIN, 0.1" SPC, 2 X 2, VERT, MALE	PT1414	HDR321079	HC22
1	P1	32-1083	HDR, 14 PIN, 0.1" SPC, 2 X 7, VERT, MALE	PT1074	HDR321083	HC72
1	P4	32-2001	HDR, 40 PIN, 0.1" SPC, 2 X 20, 0.025" SQ PIN, VERT, MALE	PT1794	HDR322001	HC202M
1	P18	32-2009	HDR 10 PIN 0.1" SPC 2 X 5 VERT MALE	PT1874	HDR322009	HC52
1	J1	32-0130	CON JACK RCA PHONO SNGL RA SCRE MNT GOLD BLK INS	PT3087	J320130	RCA-RT-1
1	J6	32-1020	CON, JACK, BNC, DUAL, VERTICAL PC MOUNT, RT ANGLE	PT1520	J321020	J321020
1	JP1	32-1075	JUMPER, MINI, .100 SPC	PT1415	JP321075	PCBNULL
1	LBL1	30-0121	LABEL BARCODE AUTOINSERTABLE RAW	PT2790	LABEL300121	LABEL300121
3	L9-10 L28	26-0001	IND FBD 2.5K OHM @ 100Hz 50ma 0603 TA	PT2729	LFB260001	0603
7	L1-5 L7-8	26-0217	IND, FERRITE BEAD, 2.5K OHM @ 70MHz, 0805, T&R	PT1261	LFB260217	0805
2	MH1-2	NON-PART	NON-PART TOOLING PIN HOLE 156MIL HOLE	PT2794	MH156-TOOL	MH156-TOOL
1	MP1	NON-PART	NON-PART MECHANICAL PLATED HOLE 300 PAD 156 HOLE #6	PT3001	MP300H156	MP300H156
1	P3	32-0205	CON PLUG XLR CHASSIS PCB MNT HOR A SERIES	PT2372	P320205	XLRM-1
2	R5 R57	50-1300	RES 0 5% 1/16W SM 0603 TA	PT2508	R0-B5-0603	0603
3	R23 R56 R58	OMIT	OMIT RES 0 5% 1/16W SM 0603 TA (50-1300)	PT2509	R0-B5-06030	0603
2	R2 R21	52-1304	RES 100 1% 1/16W SM 0603 TA	PT2512	R100-B1-0603	0603
1	R151	50-1301	RES 10 5% 1/16W SM 0603 TA	PT2516	R10-B5-0603	0603
15	R3 R7 R9 R15 R28-30 R33 R47 R49-50 R478-481	52-1338	RES 10K 1% 1/16W SM 0603 TA	PT2584	R10KB1-0603	0603
1	R1	50-1533	RES 110 5% 1/10W SM 0805 TA	PT1100	R110-C5-0805	0805
1	R22	52-1313	RES 1K 1% 1/16W SM 0603 TA	PT2550	R1KB1-0603	0603
1	R16	52-1347	RES 22.1K 1% 1/16W SM 0603 TA	PT2599	R22.1KB1-0603	0603
1	R90	50-1532	RES 22 5% 1/10W SM 0805 TA	PT1030	R22-C5-0805	0805
1	R52	52-1316	RES 2K 1% 1/16W SM 0603 TA	PT2553	R2KB1-0603	0603
1	R582	52-1321	RES 3.01K 1% 1/16W SM 0603 TA	PT2559	R3.01KB1-0603	0603
1	R4	52-1307	RES 332 1% 1/16W SM 0603 TA	PT2543	R332-B1-0603	0603
19	R19-20 R24-25 R27 R34-39 R42-43 R45 R48 R51 R53-55	52-0200	RES 33 1% 1/16W SM 0603 TA	PT3419	R33-B1-0603	0603
2	R26 R41	OMIT	OMIT RES (52-0200)	PT3419	R33-B1-0603-O	0603
2	R31-32	52-1328	RES 4.64K 1% 1/16W SM 0603 TA	PT2568	R4.64KB1-0603	0603
6	R8 R10-12 R17-18	52-1308	RES 499 1% 1/16W SM 0603 TA	PT2545	R499-B1-0603	0603
6	R6 R13-14 R40 R44 R46	52-1335	RES 7.5K 1% 1/16W SM 0603 TA	PT2581	R7.5KB1-0603	0603
1	R91	50-1535	RES 75 5% 1/10W SM 0805 TA	PT1101	R75-C5-0805	0805
8	TP1-8	NON-PART	NON-PART TEST POINT ENGINEERING PROBE POINT	PT1653	TESTPOINT	TESTPOINTSM
1	T2	26-3605	XFR SHIELDED DIGITAL AUDIO SM TA	PT2431	TR263605	XFR-11
1	U14	72-5426	IC, 74AC04, HEX INVERTER, SO14, T&R	PT1325	U74AC04-S	SO14

1	U11	72-1441	IC, 74HC08, QUAD 2-INPUT POS-AND, SO14	PT1421	U74HC08-S	SO14
1	U8	72-1401	IC, 74HCT14, HEX SCHMITT TRIGGER INVERTER, SO14	PT1356	U74HCT14-S	SO14
1	U1	72-0020	IC, 74LCX244, LV, OCTAL BUFFER LINE DRV W/3-STATE OUTPUTS, SO20W, T&R	PT1798	U74LCX244-S	SO20W
1	U9	72-1266	IC, AK5383, 96 kHz, DUAL 24BIT ADC, SO28W	PT1557	UAK5383-S	SO28W
1	U10	72-1466	IC, DSP56362, DSP PROCESSOR, QFP144-20X20	PT1316	UDSP56362-Q	QFP144-20X20
1	U4	72-0111	IC MK1575-01 PLL CLOCK RECOVERY	PT3135	UMK1575-01-T	TSSOP16
1	U2	72-5434	IC NC7SZ125 TNYLGC UHS BUFFER SM TA	PT1881	UNC7SZ125-S	SOT23-5
1	U3	72-0123	IC NCP303LSN30T1 V-DET 3V LOWOUT DLY SM	PT3115	UNCP303LSN30T1-S	SOT23-5
1	U19	72-0158-02V1	IC EPM240 CPLD QFP100 SM	DB105	UP720158-02V1	QFP100-14X14
1	U40	72-3136-01V1	IC, 27E512, 64K X 8, 70nS, EEPROM, DUAL TUVE MIC PREAMP, V1.00	PT1765	UP723136	PLCC/R-32
1	Y1	76-0046	OSC 22.5792MHz +3.3V SM	db704	Y22.5792M760046	OSC-FXO-31F
1	Y2	76-0045	OSC 24.576MHz +3.3V SM	PT3030	Y24.576M760045	OSC-FXO-31F