



***METS***<sup>™</sup>  
**MODEL E-112**  
**(115 VAC, 50/60 Hz)**

**USER'S MANUAL**

- **INSTALLATION**
- **OPERATION**
- **MAINTENANCE**

Important Safeguards	3
Introduction	4
Installation	4 – 5
Operation	6
How to Change a METS-E112 Cartridge	7
Draining METS Cartridge for Shipping	8
Poppet Valve Removal	9
Bellows Pump Flow Adjusting Instructions	10
Optimal Performance Notice	11
Disclaimer	12
Statement of Warranty	13

## RECOMMENDATIONS

Read the entire instruction manual *before* installation or operation of the METS mini environmental treatment system. It will help you to understand the operation of the system, how various sub assemblies work together and the operating sequence of the controls.

---

**WARNING: NEVER ATTEMPT TO PERFORM ANY ELECTRICAL TROUBLESHOOTING ADJUSTMENT(S) OR SERVICE(S) UNLESS YOU ARE A QUALIFIED ELECTRICIAN, ELECTRONICS TECHNICIAN OR FACTORY TRAINED SERVICE TECHNICIAN.**

---

## IMPORTANT SAFEGUARDS

When using your METS mini environmental treatment system, these basic safety precautions should be followed:

1. Read and understand all instructions.
2. Care must be taken to avoid burns from touching hot parts.
3. Do not operate this appliance with a damaged cord or if appliance has been dropped or damaged until it has been examined by a qualified service technician.
4. Do not let power cord hang over edge of table or counter or touch hot surfaces.
5. An extension cord should not be used with this unit. The unit should be plugged directly into a power outlet.
6. To protect against electrical shock hazard, do not immerse this appliance in water or other liquids.
7. To avoid electrical shock hazard, do not disassemble this appliance. Call a qualified service technician when service or repair work is required. Incorrect reassembly can cause electric shock hazard when the appliance is switched ON.

SAVE THESE INSTRUCTIONS

## INTRODUCTION

The METS E-112 is designed to pump silver bearing liquid through two metallic replacement cartridges. The METS metering pump controls the flow rate (factory set at 100 mls/minute) to ensure the maximum amount of silver is recovered.

The METS unit is ideal for minilabs, allowing them to meet tough environmental regulations for silver of 1mg/L (1 ppm) or less when used with the BIG-MO steel wool cartridges. Capacity performance will depend on silver concentration, flow rate, solutions composition and pH (which must be below 7.8). These simple to operate units are easy to install and monitor.

## INSTALLATION

The METS E-112 unit can be installed "ON-LINE" with processor overflows directly plumbed to the METS unit or "OFF-LINE" where the operator must manually transfer overflow solutions.

### "ON-LINE" Installation

1. Place the METS unit in a central location near both the C-41 and RA-4 processor, with access to a floor drain and electrical outlet.
2. Using plastic (PVC) "Y" or "T" fittings, connect the RA-4 bleach-fix and stabilizer to the C-41 fixer and stabilizer.

### **NOTE: DO NOT RUN DEVELOPER THROUGH THE METS UNIT!**

3. Connect the combined C-41 and RA-4 overflow to the inlet of the METS unit.
4. Connect the pump outlet to cartridge #1 inlet.
5. Connect the cartridge #1 outlet to cartridge #2 inlet.
6. Connect the cartridge #2 outlet to the drain. Make a gentle loop in drain tube line after quick disconnect. (Creates an air barrier to decrease build-up)
7. Connect the safety overflow from the METS E-112 unit to the drain. If a drain is not available, place a bottle or small tank (not supplied) inside the tray with the safety overflow hose inside this bottle or tank. If this container fills with liquid, immediately check the unit for clogging or malfunctioning.
8. Check all hose fittings to ensure proper connections were made.
9. FILL HOLDING TANK WITH WATER PRIOR TO USE.
10. The unit is ready for "ON-LINE" operation.

### **“OFF-LINE” Installation**

1. For an “OFF-LINE” installation, the METS E-112 unit is not directly plumbed to the processor. Choose a location with access to a floor drain and electrical outlet. The operator will be responsible for transferring processor overflows to the METS E-112.

#### **NOTE: DO NOT RUN DEVELOPER THROUGH THE METS UNIT!**

2. Connect the pump outlet to cartridge #1 inlet.
3. Connect the cartridge #1 outlet to cartridge #2 inlet.
4. Connect cartridge #2 outlet to the drain. Make a gentle loop in drain tube line after quick disconnect (creating an air barrier to decrease build-up).
5. Connect safety overflow from the METS E-112 unit to the drain.
6. Check all hose fittings to ensure proper connections were made. If drain is not available, place a bottle or small tank (not supplied) inside the tray with the safety overflow hose inside this bottle or tank. If this container fills with liquid, immediately check unit for clogging or malfunctioning.
7. FILL HOLDING TANK WITH WATER PRIOR TO USE.
8. The unit is ready for “OFF-LINE” operation.

## OPERATION

BIG-MO silver recovery cartridges are recommended for METS E-112 units. They can be ordered from CPAC at 800-828-6011. When using these cartridges, a flow rate of 100 ml/minute is used. The first cartridge should be changed after treating 600 gallons. If your silver discharge limit is 5mg/L (ppm), the cartridges may sustain a longer operating period.

For safety reasons, the METS E-112 unit is equipped with a 6 PSI pressure relief valve.

Pump flow rate is factory set at 100 ml/minute. If an adjustment is necessary, refer to BELLOWS PUMP FLOW ADJUSTING instructions.

For optimal performance and efficiency, the paper bleach-fix (and washless stabilizer) and film fixer (& washless stabilizer) should be drained into the METS collection tank together. This allows a uniform solution to be treated. METS units plumbed directly to the processor will automatically receive this mixture.

### **Weekly Maintenance Procedure**

### **EXTREMELY IMPORTANT!**

Run two to three gallons of warm (or hot) water through the unit once a week by pouring water into the holding tank. This reduces build-up in the cartridges, lines and quick disconnects. Clean reusable filter.

### **Control Box**

- Power – A green LED illuminates when the METS E-112 unit is plugged in.
- Overflow – An audible alarm is constant when an overflow condition exists. When this alarm sounds do not add solution to the holding tank.
- Circuit Breaker – A circuit breaker is located on the control box to protect against electrical overloads.

## How to Change a METS-E112 Cartridge

1. Fill the holding tank of the METS E-112 unit.
2. Allow all the water to pump through the cartridges (2 gallons will take 1 ¼ hours).
3. Turn off the power by using the CRT BRK button on the control box.
4. Remove the new cartridge from the shipping container.  
**DO NOT THROW AWAY THE BOX.**
5. Using the quick disconnect fittings on the cartridges, remove cartridge #1 from the machine. Set aside for draining.
6. Move cartridge #2 to the #1 position and reconnect the units quick disconnect fitting to the bottom of the cartridge.
7. Place the new cartridge in the #2 position and connect top fitting of #1 to bottom fitting of #2 cartridge.
8. Connect top fitting of #2 cartridge to drain or waste tank.
9. Turn machine on. Pour four gallons of water in the holding tank.

## DRAINING METS CARTRIDGE FOR SHIPPING

The draining procedure does not interfere with the operation of the METS unit. Once a cartridge is drained, it cannot be reused (refer to drawing below).

1. Place cartridge just removed on top of installed cartridges. This cartridge will be HEAVY.
2. Connect fitting on bottom of cartridge to the Cartridge Drain fitting on the METS E-112 unit.
3. Snap insert half of drain kit into top disconnect fitting on cartridge.
4. Allow the cartridge to drain completely (approximately one or two hours).
5. Remove insert fitting from top disconnect on cartridge being drained.
6. Disconnect bottom fitting from cartridge drain fitting on METS E-112 unit.

**FOLLOW THE PROVIDED INSTRUCTIONS FOR SHIPPING. IF YOU HAVE ANY QUESTIONS OR CONCERNS PLEASE CALL 800-828-6011.**

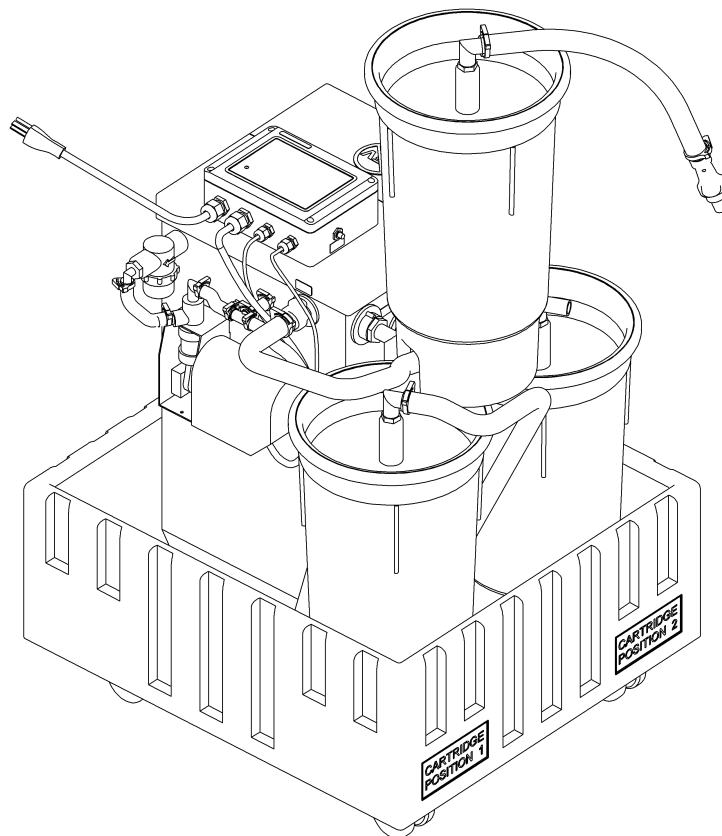



## POPPET VALVE REMOVAL, CLEANING AND INSTALLATION PROCEDURES

1. Pinch off tubes near the pump's connectors.
2. Unscrew connector nuts, pull off tubing and nut connector assemblies.
3. Remove valves from valve body;
  - a) Suction side – Pull valve out by the stem, the O-ring will come out with the valve.
  - b) Discharge side – Use a small flat screwdriver to remove the o-ring. With o-ring removed, pull valve out of the valve body with needle nosed pliers.
4. Wash poppet valve assemblies or discard and replace.
5. Reinstall in reverse order of removal. Suction and discharge valves are interchangeable. Valves are always installed before o-ring.

### VALVE ASSEMBLY PROCEDURE

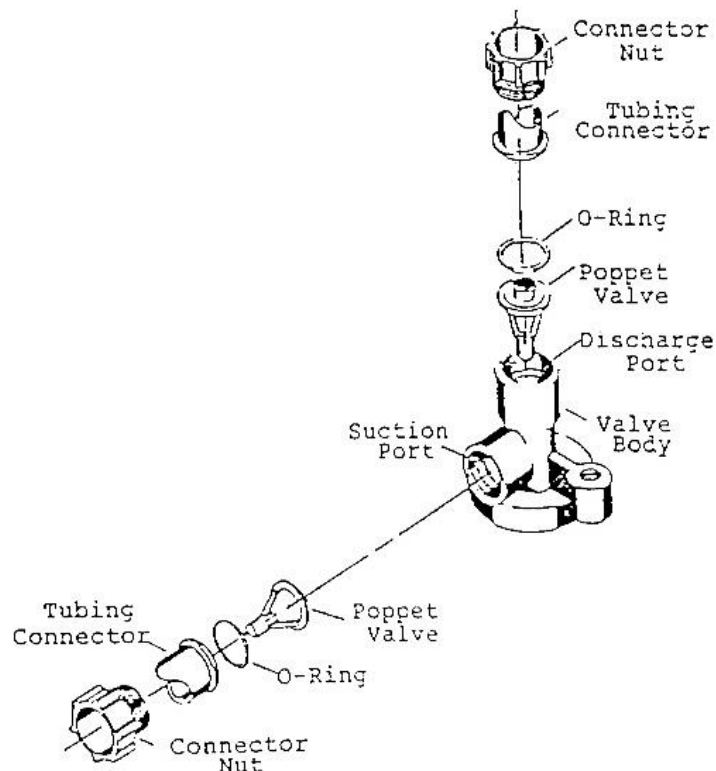

## BELLOWS PUMP FLOW ADJUSTING INSTRUCTIONS

1. Do **not** attempt to adjust flow while pump is running.
2. Clockwise rotation of the adjusting screw increases pump stroke until achieving 100% stroke. Do **not** attempt forced rotation of the adjusting screw after indicator reaches 100% and a “bottoming” resistance is experienced.
3. Counter-clockwise rotation of adjusting screw decreases stroke.
4. Only eight clockwise revolutions adjust stroke from 0% to 100%. One-half inch bellows pump requires only four revolutions.
5. It is not necessary to loosen set screw.

**NOTE: Do not add lubricants to any pump mechanism.**

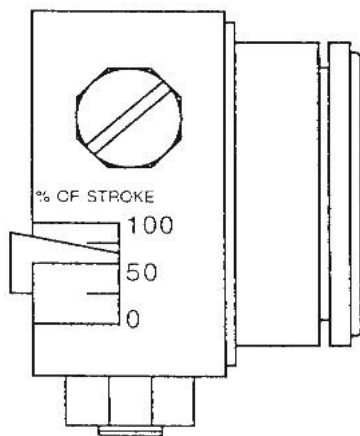
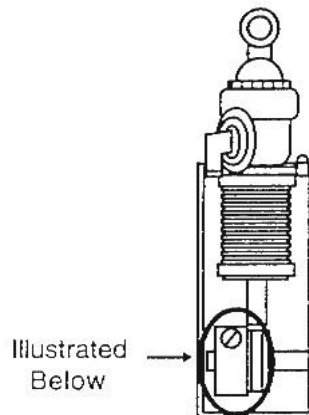

1/2" BELLOWS

CRANK  
ADJUSTING SCREW  
(5/16 HEX w/SLOT)

STROKE INDICATOR  
STROKE SCALE

SET SCREW

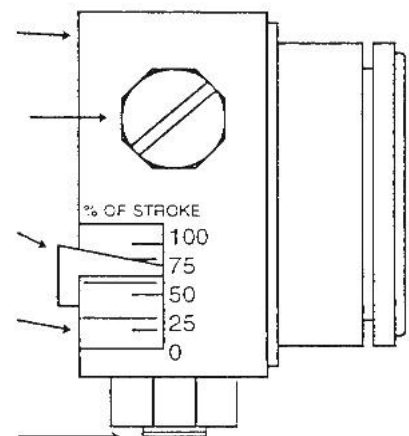

S 1" to 1-1/2" BELLOWS

**FOR BEST PERFORMANCE AND EFFICIENCY, THE PAPER BLEACH-FIX (AND WASHLESS STABILIZER) AND FILM FIXER (AND WASHLESS STABILIZER) SHOULD BE DRAINED INTO THE METS COLLECTION TANK TOGETHER. THIS ALLOWS A UNIFORM SOLUTION TO BE TREATED. METS UNITS PLUMBED DIRECTLY TO THE METS UNITS WILL AUTOMATICALLY RECEIVE THIS MIXTURE.**

**EVERY EFFORT HAS BEEN MADE TO INSURE THE COMPLETE ACCURACY OF THE CONTENTS OF THIS MANUAL. NO LIABILITY ARISING FROM ITS USE, HOWEVER, CAN BE ACCEPTED BY THE COMPANY, WHO RESERVES THE RIGHT, WITHOUT PRIOR NOTICE, TO ALTER THE SPECIFICATIONS, CONSTRUCTION, OR CONTENT OF ITS EQUIPMENT AT THE COMPANY'S OWN DISCRETION.**

## **Statement of Warranty**

All equipment is manufactured to exacting standards and has been tested and inspected for proper workmanship and performance before shipping.

Any parts which are defective will be repaired or replaced within a one year period after date of shipment, provided the equipment has been used according to the instruction manual and have not been abused or tampered with.

The company will not be responsible for any damage resulting from leakage of water or chemicals caused by improper installation, operator carelessness or defective/loose plumbing fittings associated with installation and operation of the equipment. The company assumes no responsibility for damage in transit and the customer should resent any claim for such damage to the carrier.

This warranty gives you specific legal rights. You may also have additional rights that vary from state to state.

Any unit to be repaired under warranty must be shipped, freight prepaid, or delivered to a facility authorized to render services provided hereunder. Returned unit must be either in its original package or a similar package affording an equal degree of protection. All units must have a Material Return Authorization code (MRA) visible on the returned item. MRA's can be obtained by calling 585-382-3223.