



**RV Products Division**

## **INSTALLATION INSTRUCTIONS**

**FOR**

**8330\*63(3,4)\* COOL ONLY A/C**

**8330\*635\* HEAT READY A/C**

**8530\*63\*\* HEAT PUMP**

**CHILLGRILLE™**

**FLUSH MOUNT CEILING ASSEMBLY**

**DESIGNED AND MANUFACTURED BY THE MAKERS OF  
COLEMAN®-MACH® AIR CONDITIONERS**

# TABLE OF CONTENTS

<b>Warnings</b> .....	<b>2</b>
<b>Package Contents</b> .....	<b>2</b>
<b>General Information</b> .....	<b>3</b>
<b>Ceiling Plenum Installation Requirements</b> .....	<b>3</b>
<b>Supply Ducting and Registers</b> .....	<b>4</b>
<b>Routing Thermostat Wiring</b> .....	<b>5</b>
<b>Routing 115 VAC Wiring</b> .....	<b>6</b>
<b>Ceiling Plenum Mounting</b> .....	<b>6</b>
<b>Connect 115 VAC Wiring</b> .....	<b>7</b>
<b>Connect Thermostat Wiring</b> .....	<b>8</b>
<b>Install Air Grille Assembly</b> .....	<b>9</b>

## WARNINGS

### IMPORTANT NOTICE

These instructions are for the use of qualified individuals specially trained and experienced in installation of this type equipment and related system components.

Installation and service personnel are required by some states to be licensed. **PERSONS NOT QUALIFIED SHALL NOT SERVICE THIS EQUIPMENT.**

### WARNING

Improper installation may damage equipment, can create a hazard and will void the warranty.

The use of components not tested in combination with these units will void the warranty, may make the equipment in violation of state codes, may create a hazard and may ruin the equipment.

### WARNING – SHOCK HAZARD

To prevent the possibility of severe personal injury or equipment damage due to electrical shock, always be sure the electrical power to the appliance is disconnected during installation.

**CAREFULLY FOLLOW ALL INSTRUCTIONS AND WARNINGS IN THIS BOOKLET TO AVOID DAMAGE TO THE EQUIPMENT, PERSONAL INJURY OR FIRE.**

### NOTE

**The words “Shall” or “Must” indicate a requirement which is essential to satisfactory and safe product performance.**

**The words “Should” or “May” indicate a recommendation which is not essential and not required but which may be useful or helpful.**

## PACKAGE CONTENTS

- |  |  |
|--|--|
| <ul style="list-style-type: none"> <li>1) Wirebox Assembly</li> <li>1) Duct Divider Board – Some models do not have Divider Boards (boards are provided bulk packed)</li> <li>1) Insulated Duct Locator Plate</li> <li>1) Air Grille Assembly</li> <li>1) Installation Instructions</li> </ul> | <ul style="list-style-type: none"> <li>1) Mount Frame</li> <li>1) Small Parts Package Consisting Of:                             <ul style="list-style-type: none"> <li>4) Bolts</li> <li>4) Screws – 3/8” Length</li> <li>1) Strain Relief</li> <li>2) Metal Wing Nuts</li> <li>3) Wire Nuts</li> <li>3) Screws – 3/4” Length</li> <li>1) Evaporator Freeze Sensor</li> </ul> </li> </ul> |
|--|--|

## GENERAL INFORMATION

The flush mount ceiling plenum is designed for application in systems that utilize field fabricated (OEM supplied) cold air ducting. The ducting must be routed through the ceiling cavity (between the interior ceiling and roof). Ducting specifications are given in the section labeled "Supply Ducting and Registers".

This system utilizes a single, non-ducted centrally located return air opening. The return air opening is contained within the ceiling plenum. The ceiling plenum must be located directly below the roof opening used for mounting the roof top unit.

All manual controls have been removed from the ceiling plenum. They have been replaced with control relays. The relays are mounted in the electrical box of the ceiling plenum. The relays contain 12 VDC coils (which are energized by a wall mounted thermostat), with contacts that control the 115 VAC used to power the roof top unit.

All air conditioning functions are controlled by the low voltage wall mounted thermostat. The thermostat controls a 12 VDC electrical circuit which is used to energize the relays in the ceiling plenum. The thermostats that Airxcel, Inc. provides for the system are combination (Heat/Cool) thermostats. These thermostats are capable of operating both the roof top air conditioner and any furnace with a 12 VDC control circuit of 1 amp or less (continuous current).

All air conditioning equipment is subject to freeze up when evaporator air flow is sufficiently reduced. Ducting of any length creates potential for reduced evaporator air flow and system freeze-up. To protect both the installer and Airxcel, Inc. from conditions that promote reduced air flow and system freeze-up, Airxcel, Inc. has equipped the ceiling plenum compressor control circuit with a low temperature probe. The low temperature probe monitors the temperature of the air conditioner evaporator coil. When the temperature of the evaporator coil drops below 28 degrees F, the switch will open, stopping compressor operation. Compressor operation will resume once the evaporator warms to 55 degrees F.

### IMPORTANT

**The low temperature sensor is part of the ceiling plenum electrical circuit. The probe must be inserted into the evaporator coil of the roof top unit by the installer when bolting the ceiling plenum to the roof top unit.**

The 8330 series ceiling assemblies will mount to and operate all 47200, 48200 or 49200 series roof top air conditioners.

The 8530 series ceiling assemblies will mount to and operate all 47000, 48000 or 49000 series roof top heat pumps.

## CEILING PLENUM INSTALLATION REQUIREMENT

1. The ceiling plenum must be installed under the roof opening.  
  
The ceiling plenum bolts below the roof top unit. Compression of the framed ceiling cavity between the roof top unit and the ceiling plenum is what holds both components in place.
2. Ceiling cavity depth (the measurement from the ceiling to the roof – maximum 6").
3. The 115 VAC service for the roof top unit must be routed into the ceiling plenum. To prevent wire pinching and to promote ease of installation, allowances must be made for routing the 115 VAC supply wiring into the front of the roof opening.
4. Thermostat wiring must be run from the wall thermostat mounting location to the wirebox low voltage terminals. To prevent wire pinching and to promote ease of installation, allowances must be made for routing the low voltage wiring into the front of the opening.
5. The wirebox has a 9 pin receptacle extending from the front. This mates with the roof unit 115 volt electrical conduit. When making this connection, verify that the plugs are properly aligned and have snapped together securely.
6. A low voltage terminal strip on the front of the box connects to the thermostat wires. The wires attach by 1/4" quick connects.

Plenum Terminal Designation	Thermostat Wire Connection	Function Of Low Voltage Terminal Extending From Ceiling Plenum
B Y GH GL FREEZE FREEZE	BLUE YELLOW GREEN GRAY WHITE	Completes -12 VDC circuit for all relays Energizes coil on Compressor Relay Energizes coil on High Fan Relay Energizes coil on Low Fan Relay Evaporator Freeze Sensor Connections
W	WHITE	Energizes coil on Heat Relay

“Cool Only” Boxes

“Heat Ready” Boxes

## SUPPLY DUCTING AND REGISTERS

### A. Ducting

1. The field fabricated supply ducting must attach to both sides of the ceiling plenum. A minimum of two ducts are required, with one duct attached to each side of the plenum (See Figure 1).
2. Each duct must have a minimum height of 1 1/2", maximum height cannot exceed 4 inches. Total free area inside each duct must be no less than 10 square inches.

#### NOTE

To decrease restriction and increase air flow, the ducting should make as few bends and turns as possible. When corners or turns are required, we recommend that you radius the corners to keep air flow at a maximum.

Ten (10) square inches of free area per duct is the minimum requirement, larger ducting will improve air flow and system performance.

3. Where ducting secures to the ceiling plenum, maximum width is 8 inches.
4. All field fabricated cold air supply ducting must be insulated and must have a vapor barrier.

#### IMPORTANT

**Insulation reduces cooling loss and helps prevent water staining of the vehicle ceiling due to moisture condensation.**

### B. Registers

Supply (cold air) registers should have a minimum discharge area of 48 square inches per system, or 24 square inches per duct. A minimum of 6 is recommended.

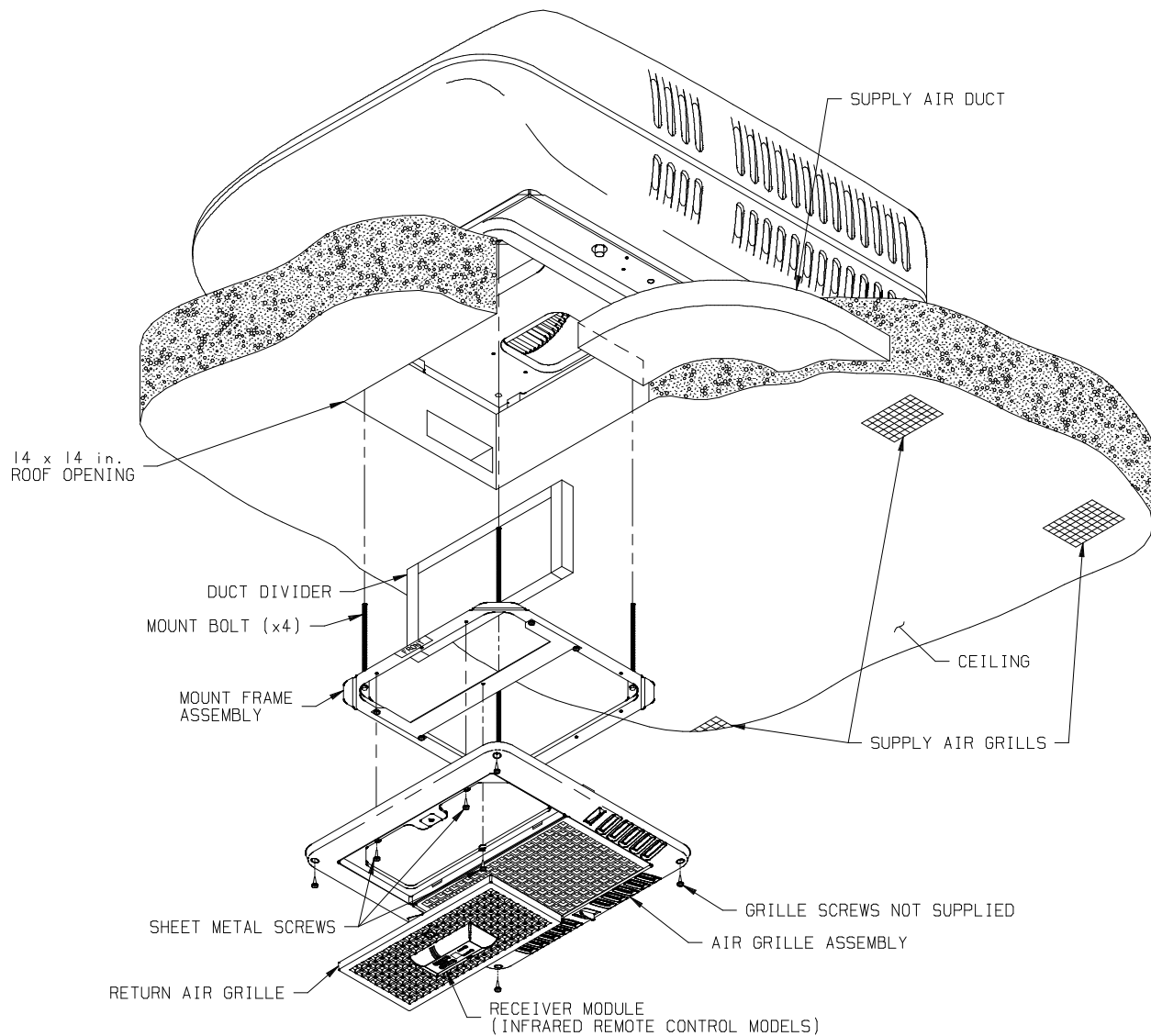

**FIGURE 1**

## **ROUTING THERMOSTAT WIRING**

1. Following the instructions packed with the thermostat, determine a location for the thermostat mounting.
2. Following Airxcel, Inc. low voltage wiring specifications and all local and national electrical codes: For 12 VDC thermostats, it is required that the thermostat 12 volt negative connection be routed directly from the converter or battery. It is highly desirable to provide 12 volt control power from the battery side of the converter. These precautions should prevent control problems.
  - A. Route the thermostat 12 VDC supply wiring from the power source to the thermostat mounting location.

Two wires are required:

One supply lead must be +12 VDC and red in color.

The second supply lead must be -12 VDC and blue in color.

- B. To protect the wall mount thermostat from over-current damage, a 2 amp fuse has been provided with the thermostat.
- C. Route the thermostat control wiring from the thermostat mounting location into the front of the ceiling plenum opening.

Four (4) wires are required (5 wires for heat/cool boxes). These wires are as follows:

- (1) Blue wire for -12 VDC circuit
- (1) Yellow wire for compressor circuit
- (1) Green wire for high fan circuit
- (1) Gray wire for low fan circuit
- (1) White wire for heat circuit

3. Airxcel, Inc. low voltage wiring specifications:

- A. All low voltage wiring should be 18 gauge minimum.
- B. Low voltage wiring must be routed into the front side of the ceiling plenum opening.

## ROUTING 115 VAC WIRING

- 1. Following Airxcel, Inc. high voltage wiring specifications and all local and national electrical codes, route the roof top unit 115 VAC supply wiring from its power source to the wirebox.

For lengths greater than 50', use #10 AWG or larger copper conductors. Match to the overcurrent protection device provided.

Circuit Protection – Refer to upper unit nameplate.

### **High Voltage Wiring Specifications based on Minimum Overcurrent Protection Device Amperage – (see upper unit nameplate)**

- 1. U.L. requires copper conductors only with minimum #12 AWG when using the minimum recommended overcurrent protection device. Higher rated devices or longer wiring runs will require #10 AWG or greater copper conductors.
- 2. To prevent voltage drops greater than 10% during starting, adhere to the following guideline:

### **High Voltage Wiring Specifications based on Overcurrent Protection Device rated higher than the minimum required (see upper unit nameplate)**

**Follow all local and NEC (National Electrical Code) for proper sizing of wire AWG based on Overcurrent Protection Device selected and the length of the wiring run to the air conditioner.**

## CEILING PLENUM MOUNTING

### **A. Mounting (Refer to Figure 1) in Retro-Fit Application, Remove and Discard the Existing Insulated Plate and Skip to Step #2 of Item B.**

- 1. Place the air conditioner over the roof opening.
- 2. Position the mount frame into the ceiling opening (See Figure 1).
- 3. Using the four bolts provided, secure the mount frame to the roof top unit. The four mounting bolts are to be applied up through the bottom of the mount frame and into the bottom of the roof top unit (See Figure 1). Tighten each bolt until the indicators of the gasket are at roof level.
- 4. Route the conduit into the return opening.

### **B. Refer to Figure 1**

- 1. Measure the distance between the ceiling and the upper unit basepan, add 1/2" to this measurement and cut the duct divider to this height if necessary. ALWAYS CUT OFF THE BOTTOM EDGE (THE EDGE WITHOUT FOAM STRIP).
- 2. Carefully wedge this divider between the walls of the roof opening and up against the upper unit basepan with the silver side facing forward. Some upper unit mount gaskets have a locator block on each side to locate the divider board.
- 3. Attach the duct locator plate to the mount frame using 4 short screws found in the small parts package.
- 4. Apply enclosed wiring diagram to duct divider board.

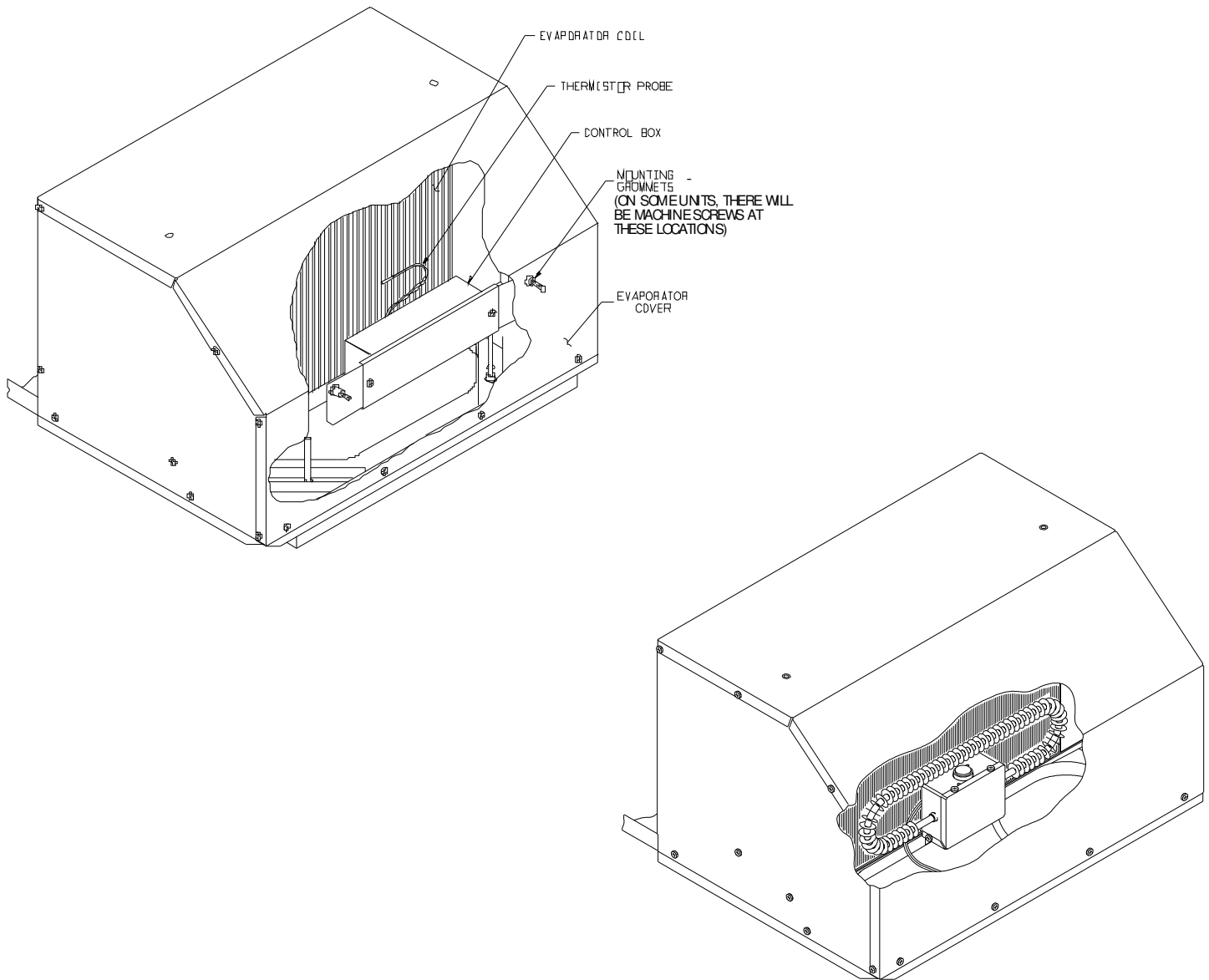

FIGURE 2

## CONNECT 115 VAC WIRING

### 1. WARNING – SHOCK HAZARD

To prevent the possibility of severe personal injury or equipment damage due to electrical shock, always be sure the electrical power is disconnected or off before beginning installation.

- Complying with the “Danger” notice below, bring the 115 VAC supply wiring previously routed into the frame of the roof opening, through the strain relief atop the electrical box and into the high voltage wiring area.

### DANGER

WHEN USING NON-METALLIC SHEATH SUPPLY CABLES (ROMEX, ETC.), STRIP SHEATH BACK TO EXPOSE 4-6 INCHES OF THE SUPPLY LEADS. STRIP THE INDIVIDUAL WIRE LEAD ENDS FOR WIRE CONNECTION (ABOUT 3/4" BARE WIRE). INSERT STRAIN RELIEF INTO ELECTRICAL BOX. INSERT THE SUPPLY WIRES THROUGH THE STRAIN RELIEF.

**IF OTHER THAN NON-METALLIC CABLES ARE USED FOR SUPPLY CONDUCTORS, APPROPRIATE STRAIN RELIEF CONNECTORS OR CLAMPS SHOULD BE USED.**

**IN NO CASE SHOULD CLAMPING OR PINCHING ACTION BE APPLIED TO THE INDIVIDUAL SUPPLY LEADS (NEUTRAL AND “HOT” WIRES).**

3. Connect high voltage supply leads to the control box wire leads with provided wire nuts. “Hot” connects to black lead, “neutral” to white lead and “ground” to green lead.
4. Gently fold all wiring into the electrical box while verifying that it is not either pinched or cut.
5. Complying with the warnings listed below, connect the 115 VAC supply wiring to its power source. Be sure all power remains off until beginning checkout procedure.

**DANGER**

**TO PREVENT THE POSSIBILITY OF SHOCK INJURY FROM APPLIANCE OPERATION:**

**THE WHITE WIRE MUST BE CONNECTED TO NEUTRAL IN THE SERVICE BOX ENTRANCE AND THE MECHANICAL GROUND MUST BE CONNECTED TO A GROUNDING LUG IN THE SERVICE BOX OR THE MOTOR GENERATOR COMPARTMENT.**

**IMPORTANT**

**When connecting the 115V electrical conduit:**

1. **Make any adjustments required to relieve pinched or stressed wiring.**
2. **Verify that the “ridged” side of both plugs are properly aligned. Verify that the connectors have snapped together on both sides. Do not use excessive force when joining the connectors.**

**CONNECT THERMOSTAT WIRING**

**A. Ceiling Plenum Connections**

1. Bring the thermostat wiring previously routed into the roof opening to the low voltage terminal board extending from the front of the ceiling plenum electrical box.

These low voltage ceiling plenum designations complete the following circuits:

- B -12 VDC for all relay coils
- Y +12 VDC for compressor relay coil
- GH +12 VDC for hi fan relay coil
- GL +12 VDC for low fan relay coil
- W +12 VDC for heat relay – found on heat ready boxes

**B. Mounting the Wirebox (See Figure 2)**

1. Two machine screws are on the upper units. The control box will be mounted by positioning the control box over the screws and using the wing nuts to fasten the control box to the upper unit. Installation in a 47000 series unit will require mounting the control box with the wires exiting upwards (See Figure 4).
2. Insert the freeze circuit thermistor probe into the roof top unit evaporator coil. Verify that the probe is located in the coil properly (See Figure 2).

The optional heater assembly may now be installed. Refer to Figures 2 and 3 for the 48000 and 49000 series units. Refer to Figure 5 for the 47000 series units.

Position the heater assembly into the return air opening as shown (for 48000 and 49000 series). The heater bracket **must be installed between the basepan and the plastic drain pan.** See Figure 3.

Tighten set screw to secure the assembly so as to prevent movement. The 47000 series installation will use wing nuts to secure the heater as in Figure 5.

Insert the two-pin connector of the heater umbilical into the receptacle on the control box. Insure that the connector snap-locks into position.

**CHART 1**

Ceiling Plenum Low Voltage Wire Designations	Mate With	Wall Thermostat Control Wiring
B		Blue
Y		Yellow
GH		Green
GL		Gray
W		White

After completion of high and low voltage wiring, replace the wirebox cover.



**TIE ALL WIRING TO INSURE NO CONTACT WITH THE HEATER OR ANY SHARP EDGES. KEEP IN MIND THAT HIGH VELOCITY AIR WILL BE ENCOUNTERED IN THIS AREA.**

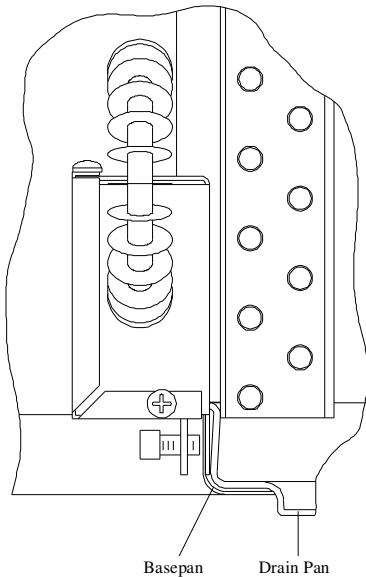

**FIGURE 3**

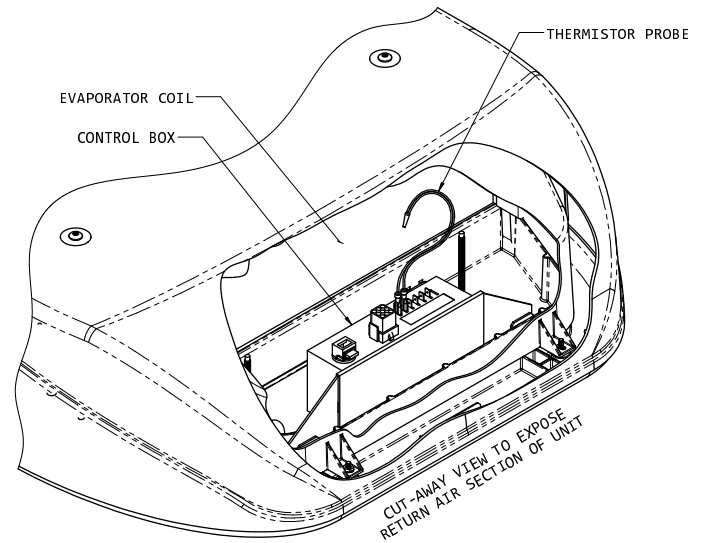

**FIGURE 4**

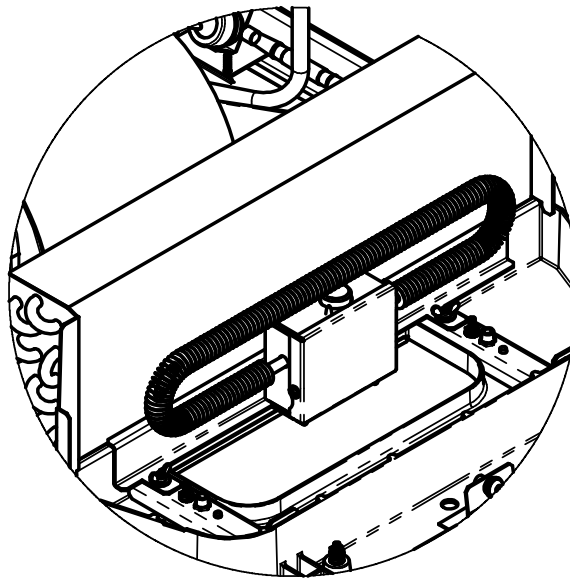

**FIGURE 5**

## **INSTALL AIR GRILLE ASSEMBLY**

1. Temporarily remove the air grille assembly filter door. A quarter-turn of the fastener will disengage the door. Attach the air grille frame to the mount frame with 3 screws as shown in Figure 1 – use 3/4" screws. Adjust as desired to insure that all foam parts are within the grille perimeter, and secure the corners of the grille to the ceiling. These 4 corner screws are not provided. Check all fits to insure that a reasonably air tight seal exists to separate unit supply air from unit return air. Re-install the filter door.
2. Installation is now complete.



Airxcel, Inc.  
RV Products Division  
P.O. Box 4020  
Wichita, KS 67204

Web: [www.rvcomfort.com](http://www.rvcomfort.com)  
Support: [www.rvpsupport@airxcel.com](mailto:www.rvpsupport@airxcel.com)  
Sales: [www.rvpsales@airxcel.com](mailto:www.rvpsales@airxcel.com)