

EVALUATING AIR CONDITIONER PERFORMANCE

From AIRXCEL, INC. - RV Products Division, the exclusive manufacturer of Coleman[®]-Mach[®] rooftop and basement packaged air conditioners and heat pumps.

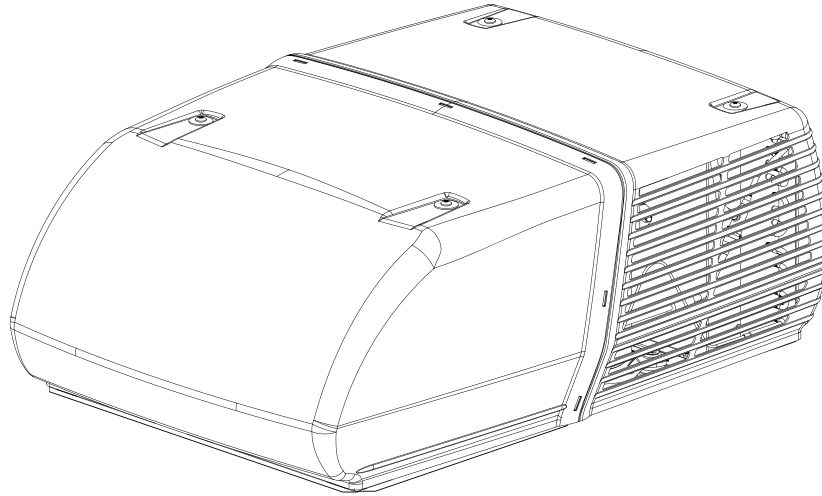

I think my air conditioner needs refrigerant. What do you think?

This question has been asked countless times. The answer is, your air conditioner is not any more likely to need refrigerant than your refrigerator. When was the last time you added refrigerant to your refrigerator? The truth is most cooling problems are related to poor maintenance, improper usage, or improper installation.

Evaluating the performance of a Coleman[®]-Mach[®] Series Air Conditioner is relatively simple and requires only a Thermometer, an Ammeter, and some basic hand tools.

NOTE: Cooling performance tests can only be effectively done at ambient temperatures above 75° F / 24° C.

The first and foremost thing to do when you are evaluating any air conditioner's performance is a visual inspection of the unit. Check the installation of all connecting duct collars or divider plates which separate the return and discharge/supply air. Any leakage from the supply air to the return is a loss in capacity to the RV and must be sealed.

Continuing with the visual inspection, you must make sure the return air filter(s) and the evaporator and condenser coils are clean and undamaged. Clean and straighten the fins on both coils and clean the filter(s) as necessary before starting a cooling performance test. More than likely by the time you get this far you have already fixed any problem that may exist.

After cleaning the unit and inspecting the air conditioner installation, conduct a Cooling Performance Test as follows:

1. Measure the evaporator temperature difference:

- a. Open all discharge/ supply registers fully.
- b. Turn the selector switch or wall thermostat to the HIGH COOL position.
- c. Allow the air conditioner to run for at least a half an hour, longer if possible. This is necessary to fully cool the evaporator coil and saturate the unit with condensate water before beginning a temperature test.
- d. Use a standard dial type or digital thermometer to measure the temperature of the air immediately entering the return air filter/grille of the air conditioner.
- e. Measure and subtract the temperature of the air leaving the discharge/supply air louvers from the return air temperature. When you are testing a ducted air conditioner application be sure to measure the supply temperature at the closest register to the unit. Make sure the temperature sensing device is measuring supply air temperature only.
- f. A properly running A/C unit should have a temperature difference of approximately 16 to 22 degrees. Slightly lower temperature differences are possible under extremely humid conditions. (The unit may have to run longer to remove moisture.) Greater temperature differences than 22 degrees are possible in hot dry weather.

NOTE: Restricted air flow over the evaporator may also cause greater than 22° temperature differences. In this case even though the temperature difference is greater the capacity would be less.

2. Measure line voltage to the air conditioner.

Line voltage should be checked at the unit where the coach wiring connects to the air conditioner while the air conditioner is running. The correct operating range is between 103.5 and 126.5 VAC.

3. Measure compressor amperage.

NOTE: Allow the air conditioner to run in High Cool for at least a half an hour, longer if possible before checking compressor amperage

a. Measure the Outdoor ambient temperature. (Air entering the condenser coil)

b. Measure and record the compressor amperage on the common wire to the compressor.

NOTE: Compressor amperage may be checked at the compressor by placing a clamp-on ammeter around the compressor Black wire. As an alternative to crawling up on the roof and removing the shroud, you may choose to check the compressor amperage inside where the air conditioner plugs into the ceiling assembly. The compressor wire color at this point (in the umbilical cord) is PURPLE on all Coleman Mach series air conditioners.

c. Record the compressor Rated Load Amps (RLA). The RLA is found listed on the air conditioners rating plate.

f. The calculated and measured compressor amperages should be approximately the same.

If the compressor amperage is much **HIGHER** than it should be, look for some of these possible problems:

- low or high voltage
- dirty or damaged condenser coil fins
- excessively high indoor/outdoor temperatures
- overcharge (look for a clamp-on saddle valve)
- bad fan motor operation (no or slow speed)

If the compressor amperage is much **LOWER** than it should be, look for some of these possible problems:

- dirty filters
- dirty evaporator coil (iced up)
- no refrigerant charge

IN CONCLUSION

The air conditioner is working well if the measured and calculated compressor amperages are approximately the same and the temperature difference across the evaporator is reasonably within range.

OUTDOOR TEMPERATURE	CALCULATED APPROXIMATE COMPRESSOR AMPERAGE
95° F	Equal to RLA
100° F	RLA + 1 Amp
105° F	RLA + 2 Amps
110° F	RLA + 3 Amps
115° F	RLA + 4 Amps
90° F	RLA - 1 Amp
85° F	RLA - 2 Amps
80° F	RLA - 3 Amps
75° F	RLA - 4 Amps

d. Use the chart to calculate what your approximate compressor amperage should be based upon the outdoor temperature measured in step one.

e. Compare the amperage measured in **step b** with the calculated amperage from **step d**.

NOTE: Several factors affect actual compressor amperage, the chart does not account for low or high voltage, dirty or damaged coils, or excessively high or low indoor temperatures. However, the single largest contributing factor is the outdoor ambient temperature. Use the chart only to figure APPROXIMATE compressor amperage.



AIRXCEL, INC. - RV PRODUCTS DIVISION

3050 N. St. Francis Street

Wichita, KS 67219

314.832.3400 • www.Airxcel.com