

**TECHNICAL  
DOCUMENTATION**



**Cc2002 - 60 inch Stations**

***SERIAL # c60-500***

***Ferric Chloride Etch***

**Atlas Die, LLC.**

Revision Status:	
Version: 0.1	Date printed: 12-10-03

Chemcut Corp.  
500 Science Park Road.  
State College, Pa. 16803-2299

**1. INTRODUCTION**

**2. SAFETY**

**3. PROCESS OVERVIEW**

**4. TECHNICAL INFORMATION**

**5. SYSTEM OPERATIONS**

**6. TROUBLE SHOOTING**

**7. PREVENTIVE MAINTENANCE  
SCHEDULES**

**8. MAINTENANCE AND  
ADJUSTMENT INFORMATON**

**9. PARTS – SPARE PARTS**

**10. WARRANTY**

**11. CHEMCUT CONTACTS**

# 1 Introduction

Contents.....	Page
<b>1.1</b> <b>Scope of the Manual .....</b>	<b>3</b>
<b>1.2</b> <b>Navigation: .....</b>	<b>3</b>
<b>1.3</b> <b>Symbols.....</b>	<b>3</b>
<b>1.4</b> <b>Diagrams .....</b>	<b>4</b>
<b>1.5</b> <b>Additional Documentation .....</b>	<b>4</b>
1.5.1    Electrical .....	4
1.5.2    Chemicals.....	4

## 1.1 Scope of the Manual

This manual explains the operation, maintenance, and parts identification procedures for your Chemcut processing system. This Manual is divided into several chapters. The subject content of each chapter is listed in the “Table of Contents” on the cover page of this document (page 1). Other important information contained on the cover page includes the system serial number and the intended processes for your Chemcut system.

## 1.2 Navigation:

Navigation through this CD based document, is accomplished by “pointing” and “clicking” at links contained within the document. The central point of navigation is the “Title Page” (page 1-1). Positioning the cursor over a chapter heading (pointing), and then depressing the left mouse button, (clicking) will automatically cause the document to jump to the start of the selected chapter.

Each chapter contains links to further refine the navigation through this document. “Pointing” and “Clicking” on any page number in a chapter index page will cause the document to jump to the requested page or section of the document. Returning to the “Title Page”, is accomplished by selecting the first page of this document. Clicking on the “first page” button located on the Adobe toolbar, or sliding the vertical scroll bar to its very top position are the best methods for returning to the “Title Page”.

## 1.3 Symbols

Two symbols, placed on the right side of the page are used in this documentation to highlight points that should receive special attention:

To avoid health hazards and safety risks for personnel, please carefully observe comments indicated with the following symbol:



Points that are particularly important to the operation and maintenance of the equipment are marked with the following symbol:



## **1.4 Diagrams**

The standard transport direction is from left to right. Left to right transport direction is defined as the direction of product flow as viewed from the operator's side of the equipment. Reference diagrams included in this documentation are illustrated based on this left to right transport direction. For right to left machines, the concepts illustrated on these drawings are correct, but need to be visualized as mirror images. To help in the comprehension of these drawings, it is important to consider the "Transport Direction" that is indicated on these diagrams.

## **1.5 Additional Documentation**

### **1.5.1 Electrical**

Printed copies of the documents below are located in the electrical control cabinets:

- Layout diagram
- Schematic wiring diagrams (main and control circuits)
- Parts lists (electrical)

Note: In addition to the printed copies provided in the electrical cabinets, digital copies of this documentation and viewing software is provided on this CD.

### **1.5.2 Chemicals**

The documents below related to chemicals are supplied with the chemicals. They are not part of this document:

- Chemical safety sheets
- Instructions for the use of chemicals
- Analysis procedures



## 2 Safety

Contents.....		Page
<b>2.1</b>	<b>General information.....</b>	<b>6</b>
2.1.1	Responsibility of the owner .....	6
2.1.2	Responsibility of operators and maintenance personnel .....	6
2.1.3	Design application .....	7
2.1.4	Guarantee and liability .....	7
<b>2.2</b>	<b>Safety and protection devices .....</b>	<b>8</b>
2.2.1	Emergency stop switches .....	8
<b>2.3</b>	<b>Training of personnel .....</b>	<b>8</b>
<b>2.4</b>	<b>Equipment control .....</b>	<b>9</b>
<b>2.5</b>	<b>Safety procedures.....</b>	<b>9</b>
2.5.1	General.....	9
2.5.2	Safety procedures in normal operation.....	10
2.5.3	Safety procedures for the electrical system.....	11
2.5.4	Safety procedures for chemicals .....	11
2.5.5	Safety procedures for gases and vapors.....	12
2.5.6	Safety procedures for parts at elevated temperatures.....	12
2.5.7	Safety procedures for moving parts .....	13
2.5.8	Safety procedures for accessing internal parts.....	14
<b>2.6</b>	<b>Maintenance and repair .....</b>	<b>16</b>
<b>2.7</b>	<b>Constructional changes to the equipment.....</b>	<b>16</b>
<b>2.8</b>	<b>Cleaning the equipment and material disposal .....</b>	<b>17</b>
<b>2.9</b>	<b>Emergency procedures .....</b>	<b>17</b>
2.9.1	General.....	17
2.9.2	Panel Jam.....	17
2.9.3	Clothing or body parts caught in moving parts .....	18
2.9.4	Personnel in contact with process solution.....	18



## 2.1 General information

- This documentation contains important information about how to operate and maintain Chemcut equipment safely.
- In order to operate Chemcut equipment in a safe and trouble-free manner, a thorough knowledge of safety instructions and regulations is required.
- All personnel who work on or operate Chemcut equipment should follow the instructions in this documentation, particularly in regard to safety.
- In addition, please obey Federal, State, Local rules and regulations concerning accident prevention.

### 2.1.1 Responsibility of the owner

The owner is responsible for giving permission to operate and/or service Chemcut equipment only to those individuals who:

- are fully qualified and trained to operate or service the equipment.
- are fully aware of the regulations concerning safety at work and accident prevention.
- have read and understood the safety chapter and the safety instructions in this operation manual.

The safety awareness of the personnel operating and working on the machine should be verified on a regular basis.

All safety features on the equipment must be checked on a regular basis.

The owner must provide all necessary personal protection equipment and training in the proper operation of this equipment.

### 2.1.2 Responsibility of operators and maintenance personnel

All personnel who operate or service the machine, are responsible for:

- following all relevant regulations concerning safety at work and accident prevention.
- reading the safety chapter and safety instructions in this operation manual.





### **2.1.3 Design application**

This Chemcut equipment is solely designed for the processing of printed circuit boards through the process(es) indicated on the cover sheet, (page 1) of this document. The use of the equipment for other purposes, or the use of the system beyond its stated specifications is not recommended, and is beyond the scope of the design intent of the equipment.

In any such case, Chemcut shall not be responsible for any damage and/or lost productivity caused by the misuse or misapplication of the equipment.

In addition, proper use of the equipment includes that:

- all instructions in this documentation must be followed.
- all necessary inspection and maintenance work has to be carried out in a proper manner and in compliance with the provided maintenance schedules.

### **2.1.4 Guarantee and liability**

The CHEMCUT "General Conditions of Sale and Delivery" are absolutely binding. These are available to the owner either before or at the time of signing the contract. Guarantee and liability claims for injury to personnel or damage to equipment cannot be accepted if these arise from one or more of the following causes:

- the equipment is not used for its designed application
- improper operation and/or maintenance of the equipment
- operation of the equipment with defective safety devices or incorrectly mounted or non-functioning safety and protective devices
- non-compliance with the instructions in this documentation in regards to start-up, operation, maintenance and set-up of the equipment
- unapproved constructional changes made to the equipment by the owner
- insufficient monitoring of equipment parts which are subject to wear-and tear
- repair work carried out incompetently
- damage caused by foreign bodies or excessive force being applied to the equipment, including natural causes.

For additional information, please refer to the "Warranty" section of this documentation.



## 2.2 Safety and protection devices

- Before every equipment start-up it must be ensured that all safety and protection devices are properly mounted and in good working order.
- Safety and protection devices may only be removed;
  - after the machine has stopped completely and
  - after ensuring that the machine cannot be restarted.
- For components that are not supplied by CHEMCUT, the customer must install safety and/or protective devices according to the appropriate regulations.

### 2.2.1 Emergency stop switches

- Emergency stop switches are mounted at several positions in the line. (Input and output ends, in the middle of the operator side and near the dosing units on the service side of the line etc).
- Emergency stop switches have red activators and are mounted on a yellow background.
- Emergency stop switches comply with German VDE 0100, VGB 4, and other international requirements.
- The operation of any emergency stop switch turns off the control voltage to all line components. All contactors for pumps, motors etc. will be switched off

## 2.3 Training of personnel

- Only personnel who are specifically trained and instructed how to operate and maintain the equipment correctly may work on it.
- The responsibilities of personnel for machine operation, set-up, maintenance and repair must be defined clearly.
- Trainees may only work on the equipment under the supervision of experienced personnel.







## 2.4 Equipment control

- The software program must not be changed under any circumstances!
- Software functions, except the entering of product parameters, are password protected. It is recommended that the password be changed at least every 3 months!
- Only trained and authorized personnel may operate the controls.



## 2.5 Safety procedures

### 2.5.1 General

- Chemcut equipment is built according to current technical standards and prevailing safety regulations. However, it may be possible that its operation could present risks to the health and safety of operators or third parties. The risk of damaging the machine or other items can also arise.
- Chemcut equipment may only be used;
- for the application for which it is designed
- when all safety related functions are in proper working order
- Defects that could be dangerous to safety must be fixed immediately.
- This documentation must always be accessible in the immediate vicinity of the equipment.
- In addition to this documentation, the general and local regulations regarding accident prevention and environmental protection must be available and adhered to.
- All safety, warning notices and lettering attached to the equipment must be maintained in legible condition.



## 2.5.2 Safety procedures in normal operation

- Check the equipment visually before starting up the line. Verify that no one could be exposed to danger by machine start-up.
- The equipment may only be operated when all the safety and protection devices are fully able to function.
- Never operate the equipment with any protective covers removed.
- Never install a device or modify the electrical wiring for the purpose of over-riding a safety device.
- At least once each shift, the operation of the Emergency Stop circuit should be verified and the equipment should be checked for any visible external damage.
- All operators must know the locations of the Emergency Stop buttons, the main power disconnect switch, and any emergency shut off valves on the chemical solution lines on the system.
- Always keep clothing and body parts away from all moving mechanical parts in the equipment, i.e. gears, shafts, etc.
- Always shut off pumps prior to removing any of the spray chamber covers.
- Wear eye protection at all times when working in the vicinity of the system.
- Always wear the appropriate protective clothing when working with hazardous chemicals.
- Never manually mix chemicals in the equipment sumps. Some chemicals can release dangerous amounts of heat which could cause irreparable damage to the equipment.
- Appropriate personnel must verify the proper operation of all interlocks, protection, and ventilation devices on the equipment on a regular basis.
- Never operate the equipment when under the influence of drugs or alcohol.
- Never operate the equipment at a temperature that is not compatible with the materials of construction.



### 2.5.3 Safety procedures for the electrical system

- Only trained electricians may be permitted to work on the electrical system.
- The equipment's electrical system has to be checked regularly. Loose connections and damaged cables must be repaired immediately.
- The control cabinet should always be kept locked. Access should only be permitted to authorized personnel.
- Should work be necessary on live wires or equipment the local health and safety regulations must be observed.
- Ensure that no tools or other metallic objects have been left on the equipment or in the electrical boxes. These objects can be the source of short circuits.



### 2.5.4 Safety procedures for chemicals

- Aggressive chemicals are used in Chemcut equipment. All instructions contained in the safety information sheets, operation manual, and analysis procedures must be followed.
- Always wear the appropriate protective clothing when working with hazardous chemicals.
- All solutions and chemicals that may be used in the equipment must be handled and disposed of in accordance with established safety procedures and regulations.
- Maintenance work on modules may only be carried out after they have been emptied and cleaned.
- Maintenance work on pipes may only be carried out when the pipes are not under pressure.
- When taking samples for analysis purposes, protective clothing must be worn. The drive and pumps must be switched off.
- Never manually mix chemicals in the equipment sumps. Some chemicals can release dangerous amounts of heat which could cause damage to the equipment.
- Never operate the equipment with any chemistry or concentrations of chemistry that is not compatible with the materials of construction.





### **2.5.5 Safety procedures for gases and vapors**

- Should the exhaust system not be operating correctly, a release of dangerous gases and vapors can occur!
- Proper personnel protective equipment for dealing with such a release should be available in the immediate area.
- The performance of the exhaust system must be verified on a regular basis.
- The verification of exhaust system performance must occur at each individual exhaust connection point along the processing line.

### **2.5.6 Safety procedures for parts at elevated temperatures**

- Some tanks or other pieces of equipment may operate at an elevated temperature. Exposed surfaces pose a potential burn hazard.
- Care should be taken to avoid contact with hot surfaces while working around an area operating at an elevated temperature.
- Appropriate protective clothing must be worn when working on parts at elevated temperatures.
- Pay attention to labels indicating a hot surface.



## 2.5.7 Safety procedures for moving parts

On all Chemcut equipment, the opening of certain lids, covers, and doors will immediately stop spray pumps. This action dramatically reduces the danger of personnel being splashed or sprayed with chemicals.

On certain Chemcut equipment, the lifting of these covers will also stop the conveyor drive and oscillation mechanisms from moving. These steps are designed to reduce the possibility of personnel getting clothing or body parts caught in moving mechanical parts.

The possibility of getting clothing or body parts entangled in moving parts is often referred to as a pinch hazard. A pinch hazard may cause cuts, bruises, abrasions, and even the loss of appendages such as fingers.

**CAUTION: Extreme care should be taken to avoid contact with moving parts.**





## **2.5.8 Safety procedures for accessing internal parts**

This procedure MUST be followed when removing covers or doors from CHEMCUT equipment to access the internal processing area.

1. Read chemistry manufacturer's material safety data sheet.
2. Follow chemistry manufacturer's recommended handling procedures.
3. Know your plant emergency procedures.
4. Turn off conveyor on CHEMCUT equipment.
5. Turn off spray pumps on CHEMCUT equipment.
6. Wait 2 minutes to allow solution to drain from internal surfaces into sump.
7. Put on personal protective equipment recommended by chemistry manufacturer which can include goggles, gloves, apron and respirator.
8. Remove cover or door of CHEMCUT equipment.
9. Replace cover or door when internal access is no longer required.
10. Restart equipment in accordance with plant operating procedure.



Este procedimiento debe seguirse al quitar las tapas o las puertas del Equipo CHEMCUT para tener acceso a la superficie interna de procesamiento.

1. Leer el MSDS (pliego de datos sobre la seguridad del material) Suministrado por el fabricante.
2. Seguir procedimientos de manejo recomendados por el fabricante de la Substancia química.
3. Saber el procedimiento de emergencia de su planta.
4. Apagar el transportador del equipo CHEMCUT.
5. Apagar las bombas pulverizadoras del equipo CHEMCUT.
6. Esperar 2 minutos para permitir el drenaje de la substancia química Desde la superficie interna al sumidero.
7. Colocarse el equipo de protección personal recomendado por el Fabricante de la substancia química, que puede incluir protectores Oculares, guantes, delantal, y respirador.
8. Quitar la tapa o la puerta del equipo CHEMCUT.
9. Colocar nuevamente la tapa o la puerta cuando ya no sea necesario El acceso al interior.
10. Poner en marcha nuevamente el equipo, de acuerdo con el Procedimiento de operación de la planta.



## 2.6 Maintenance and repair

- The required set-up, maintenance and inspection work must be carried out according to the maintenance schedules, (see section 7, Preventative Maintenance Schedules)
- Before conducting any maintenance, repair, or inspection work, the Chemcut line must be switched off and the main switch securely protected against unexpected activation:
  - switch off and lock the main switch
  - remove the key (if applicable)
  - inform the machine operator(s)
  - attach a warning sign to prevent switching on
- When exchanging large and/or heavy items attach them carefully and securely to the lifting device.
- Check loose screw connections for tight fit.
- After finishing maintenance work, check all safety and protection devices for correct function.

## 2.7 Constructional changes to the equipment

- No changes or modifications to the equipment may be made without prior permission of the manufacturer. This includes welding of supporting structural parts.
- All modifications require written confirmation from Chemcut.
- Immediately replace any part of the equipment that is **not** in proper working condition.
- Only use original spare parts:

If parts are secured from suppliers other than Chemcut, Chemcut cannot guarantee that these parts have been designed and manufactured to meet the Chemcut's performance and safety requirements.





## **2.8 Cleaning the equipment and material disposal**

- Only use cleaning agents that are compatible with the materials of construction.
- All materials used must be handled and disposed of according to the relevant regulations and procedures.

## **2.9 Emergency procedures**

### **2.9.1 General**

**An emergency is defined in these procedures as an immediate situation in which personal injury is occurring or eminent, or where equipment damage is occurring or eminent.**

### **2.9.2 Panel Jam**

#### **IN THE EVENT OF A PANEL JAM:**

1. Stop the system using the appropriate Stop button.
2. Visually identify the area in which the jam has occurred.
3. Put on the appropriate personnel protective clothing and/or device(s).
4. Remove the necessary protective covers to gain access to the area where the jam has occurred.
5. Remove the jammed material from the conveyor.
6. After the jammed material has been removed from the equipment, inspect the conveyor rods in the area of the jam to be sure they are properly seated.
7. Inspect the conveyor wheels to ensure they are correctly spaced on the rods.
8. Replace the protective covers that were removed.
9. Restart the system in accordance with the established procedures.
10. Clean the equipment of any chemical splashes or spills that may have occurred while removing the jam.



### **2.9.3 Clothing or body parts caught in moving parts**

#### **IN THE EVENT OF CLOTHING OR BODY PARTS ARE CAUGHT IN MOVING MECHANICAL PARTS:**

1. Stop the system using the appropriate Stop button.
2. Render assistance to the person who is caught and immediately notify the appropriate emergency personnel in accordance with established emergency procedures.
3. Disconnect all electrical power to the equipment as soon as possible after completing step 2.

### **2.9.4 Personnel in contact with process solution**

#### **IN THE EVENT OF PERSONNEL IN CONTACT WITH PROCESS SOLUTION: (resulting from ruptured piping or some other abnormality)**

1. Stop the system using the appropriate Stop button.
2. Render assistance to the person contacted by the solution and immediately notify the appropriate emergency personnel in accordance with established emergency procedures.
3. Disconnect all electrical power to the equipment as soon as possible, after completing step 2.
4. Lockout the main power disconnect switch in the off position until the proper repairs can be made.



### 3 Process Overview

Contents.....		Page
3.1	General .....	20
3.2	Process steps.....	20
3.3	System design.....	20
3.4	<u>PLE634</u> Load and Drive .....	20
3.5	<u>PIA634</u> Conveyor Drive.....	20
3.6	<u>POS607</u> Ferric Chloride Etch.....	21
3.7	<u>POS607</u> Ferric Chloride Etch.....	22
3.8	<u>PIA634</u> Conveyor Drive.....	23
3.9	<u>PRE634</u> Unload.....	23



### 3.1 General

This Chemcut processing system provides for continuous, integrated; horizontal processing materials. Chemcut’s global product offering designed specifically for highly reliable, continuous, mass production of High Density Interconnect products.

### 3.2 Process steps

The process sequence consists of following steps.

Station. No.	Module Name	Process Step
1	PLE634	Load and Drive
2	PIA634	Load and Drive
3	POS607	Ferric Chloride Etch
4	POS607	Ferric Chloride Etch
5	PIA634	Conveyor Drive Unload
6	PRE634	Unload

### 3.3 System design

#### 3.4 PLE634 Load and Drive

- A. OVERALL LENGTH - 69.9"
- B. 1" DRAINS PIPED TO STATION 2
- C. EMERGENCY STOP BUTTON
- D. 1/4 HP DC GEAR DRIVEN CONV. DRIVE MOTOR (ON THE PLE634)
- E. DIGITAL DISPLAY OF CONV. SPEED
- F. LINEAR SPEEDS TO 140 IPM
- G. TITANIUM CONVEYOR MOTOR MOUNTING PLATE AND ADJUSTING BOLTS

#### 3.5 PIA634 Conveyor Drive

- A. OVERALL LENGTH - 69.9"
- B. 1" DRAINS PIPED TO STATION 2
- C. EMERGENCY STOP BUTTON
- D. 1/4 HP DC GEAR DRIVEN CONV. DRIVE MOTOR (ON THE PLE634)
- E. DIGITAL DISPLAY OF CONV. SPEED



F. LINEAR SPEEDS TO 140 IPM

G. TITANIUM CONVEYOR MOTOR MOUNTING PLATE AND ADJUSTING BOLTS

### **3.6 POS607 Ferric Chloride Etch**

A. OVERALL LENGTH - 54.9"

B. SUMP CAPACITY - 215 GALLONS

C. CLEAR REMOVABLE FRONT DOOR WITH INNER SPLASH SHIELD

D. CLEAR REMOVABLE REAR ACCESS DOOR

E. REMOVABLE SEE-THROUGH TOP LIDS WITH EXIT

F. REED SWITCH INTERLOCKS ON ALL REMOVE ABLE LIDS AND DOORS

G. TWO UPPER AND LOWER SPRAY RACKS (ALL RACKS ARE REMOVEABLE THROUGH THE FRONT DOOR)

H. 70, 1.5 GPM CONE NOZZLES ON THE TOP AND THE BOTTOM

I. FLOW RATE IS APPROX. 210 GPM @ 40 PSI

J. IND. SPRAY PRESSURE ADJ. FOR UPPER INPUT,UPPER OUTPUT,LOWER INPUT,AND LOWER OUTPUT RACKS

K. FOUR FRONT READABLE PRESSURE GAUGES

L. ULTRAFINE SPRAY PRESSURE CONTROL INTERNAL INDIVIDUAL SPRAY PRESSURE ADJ. FOR EACH SPRAY CHANNEL IN EACH RACK (20 TOTAL). TWENTY FRONT READABLE PRESSURE GAUGES, ONE FOR EACH CHANNEL

M. TWO 7.5 HP CENTRIFUGAL FLUID PUMPS WITH TITANIUM IMPELLERS

N. EXTERNAL FILTER UNITS W/100 MICRON BAG ELEMENTS BETWEEN SPRAY PUMPS AND SPRAY RACKS

O. RACKS OSCILLATE IN A PLANE PARALLEL TO THE WORK PIECE AND PERPENDICULAR TO THE WORK FLOW

P. TWO SYNCHRONIZED, DIRECT GEAR DRIVEN OSCILLATION DRIVE MOTORS

Q. INDEPENDENT OSC. SPEED CONTROL (TO 54 SWEEPS/MINUTE)

R. DIGITAL TEMPERATURE CONTROLLER

S. 36 KW TOP MOUNTED TITANIUM HEATERS FOR HEAT-UP FROM 60 DEG.F TO 125 DEG

F. IN 1 HOUR

T. OUTPUT DRAGOUT ROLLERS ARE DELETED

U. FOUR 6" SUMP INTERCONNECTS AT EXIT

V. 3 HP RECIRC. PUMP PIPED TO THE POS606 OF STATION 03



X. IX MODEL ETCH 1 SPECIFIC GRAVITY CONTROLLER (FED FROM RECIRCULATION LOOP) TO ACTIVATE WATER ADD TO ETCH CHAMBER #1 TO MAINTAIN SELECTED SPECIFIC GRAVITY

### **3.7 POS607 Ferric Chloride Etch**

- A. OVERALL LENGTH - 54.9"
- B. SUMP CAPACITY - 215 GALLONS
- C. CLEAR REMOVABLE FRONT DOOR WITH INNER SPLASH SHIELD
- D. CLEAR REMOVABLE REAR ACCESS DOOR
- E. REMOVABLE SEE-THROUGH TOP LIDS WITH INNER SPLASH SHIELD AT ENTRANCE AND EXIT
- F. REED SWITCH INTERLOCKS ON ALL REMOVEABLE LIDS AND DOORS
- G. TWO UPPER AND LOWER SPRAY RACKS (ALL RACKS ARE REMOVEABLE THROUGH THE FRONT DOOR)
- H. 70, 1.5 GPM CONE NOZZLES ON THE TOP AND THE BOTTOM
- I. FLOW RATE IS APPROX. 210 GPM @ 40 PSI
- J. IND. SPRAY PRESSURE ADJ. FOR UPPER INPUT, UPPER OUTPUT, LOWER INPUT, AND LOWER OUTPUT RACKS
- K. FOUR FRONT READABLE PRESSURE GAUGES
- L. ULTRAFINE SPRAY PRESSURE CONTROL INTERNAL INDIVIDUAL SPRAY PRESSURE ADJ. FOR EACH SPRAY CHANNEL IN EACH RACK (20 TOTAL). TWENTY FRONT READABLE PRESSURE GAUGES, ONE FOR EACH CHANNEL
- M. TWO 7.5 HP CENTRIFUGAL FLUID PUMPS WITH TITANIUM IMPELLERS
- N. EXTERNAL FILTER UNITS W/100 MICRON BAG ELEMENTS BETWEEN SPRAY PUMPS AND SPRAY RACKS
- O. RACKS OSCILLATE IN A PLANE PARALLEL TO THE WORK FLOW
- P. TWO SYNCHRONIZED, DIRECT GEAR DRIVEN OSCILLATION DRIVE MOTORS
- Q. INDEPENDENT OSC. SPEED CONTROL (TO 54 SWEEPS/MINUTE)
- R. 36 KW TOP MOUNTED TITANIUM HEATERS FOR HEAT-UP FROM 60 DEG.F



- TO 125 DEG
- F. IN 1 HOUR
- S. INPUT DRAGOUT ROLLERS ARE DELETED
- T. FOUR 6" SUMP INTERCONNECTS AT ENTRANCE

### **3.8 PIA634 Conveyor Drive**

- A. OVERALL LENGTH - 69.9"
- B. 1" DRAINS PIPED TO STATION 3
- C. EMERGENCY STOP BUTTON
- D. 1/4 HP DC GEAR DRIVEN CONV. DRIVE MOTOR (ON THE PRE634)
- E. LINEAR SPEEDS TO 140 IPM
- F. TITANIUM CONVEYOR MOTOR MOUNTING PLATE AND ADJ. BOLTS
- G. SLAVED TO THE DRIVE OF STATION 01

### **3.9 PRE634 Unload**

- A. OVERALL LENGTH - 69.9"
- B. 1" DRAINS PIPED TO STATION 3
- C. EMERGENCY STOP BUTTON
- D. 1/4 HP DC GEAR DRIVEN CONV. DRIVE MOTOR (ON THE PRE634)
- E. LINEAR SPEEDS TO 140 IPM
- F. TITANIUM CONVEYOR MOTOR MOUNTING PLATE AND ADJ. BOLTS
- G. SLAVED TO THE DRIVE OF STATION 01



## 4 TECHNICAL INFORMATION

Contents.....	Page
<b>4.1 Utility Requirements .....</b>	<b>25</b>
4.1.1 Overall Length .....	25
4.1.2 Overall Width .....	25
4.1.3 Conveyor Type .....	25
4.1.4 Conveyor Height .....	25
4.1.5 Conveyor Width .....	25
4.1.6 Electrical Power Supply .....	25
4.1.7 Estimated Power Requirements .....	25
4.1.8 Intermittent Cooling .....	26
4.1.9 Exhaust Venting .....	26
4.1.10 Conveyor Speed Range .....	26
4.1.11 Maximum Operating Temperature .....	26
4.1.12 Conveyor Direction .....	26
4.1.13 Product Size .....	26
4.1.14 Product Thickness .....	26
<b>4.2 Layout Drawing .....</b>	<b>27</b>





## **4.1 Utility Requirements**

Operation of this processing system requires the following utilities. It is the responsibility of the customer to provide these utilities.

### **4.1.1 Overall Length**

249.67 in.

### **4.1.2 Overall Width**

101.00 in.

### **4.1.3 Conveyor Type**

Horizontal “Modified”

### **4.1.4 Conveyor Height**

37.5 - 39 in.

### **4.1.5 Conveyor Width**

Nominal	62 in.
Effective	60 in.

### **4.1.6 Electrical Power Supply**

3 Phase 60 Hertz

480 volts

60 Hertz

### **4.1.7 Estimated Power Requirements**

100 KVA



#### **4.1.8 Intermittent Cooling**

20 gpm @ 20 psi/50°f. maximum

#### **4.1.9 Exhaust Venting**

600 cfm

#### **4.1.10 Conveyor Speed Range**

0-140 inches per minute

#### **4.1.11 Maximum Operating Temperature**

130° F in all stations

#### **4.1.12 Conveyor Direction**

Left to Right Operation

#### **4.1.13 Product Size**

Minimum 4" wide x 15"  
Maximum 60" wide x any length

#### **4.1.14 Product Thickness**

**0.015" core to 0.250"**

## 4.2 Layout Drawing

Cc2002-30 inch system

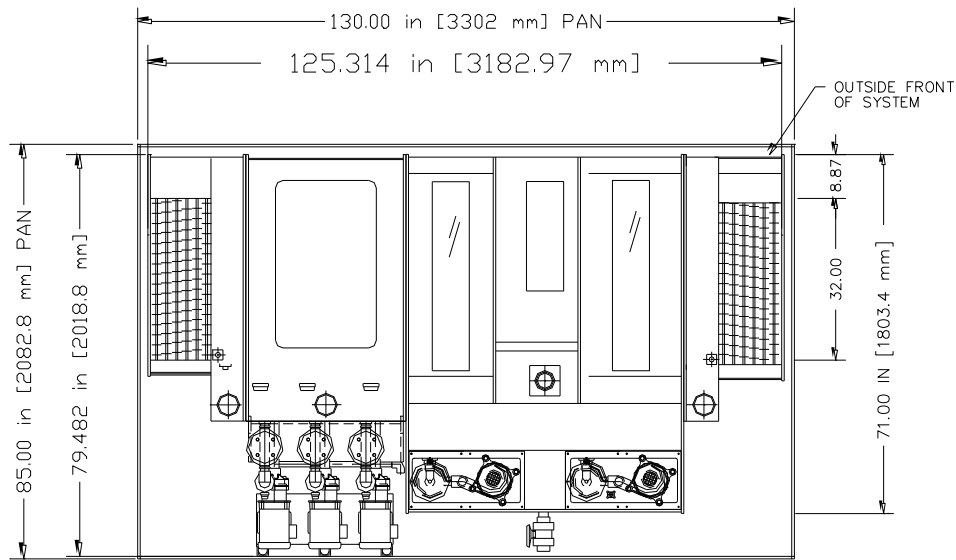

STATION NUMBER	DESCRIPTION	MODULE NAME
1	LOAD	PLE318
2	CUPRIC CHLORIDE ETCH	POS307
3	THREE STAGE ANTI-POLLUTION RINSE	PCR303
4	UNLOAD AND DRIVE	PRE318

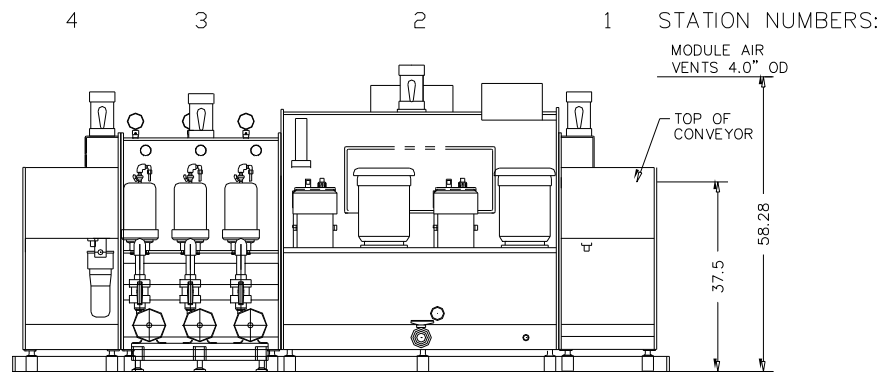

← WORK FLOW →  
 NOTE: WORK PROCESS INDICATES LEFT TO RIGHT OPERATION

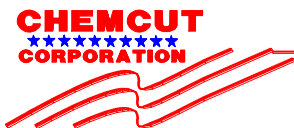

## 5 System Operation

Contents.....	Page
<b>GENERAL .....</b>	<b>29</b>
Manual / Auto Key Switch .....	29
Start / Stop Pushbuttons .....	30
Emergency Stop .....	30
Overview Screen General .....	30
Alarms .....	31
Navigation buttons .....	31
Pump / Motor Control.....	31
Alarm Acknowledge / Alarm Reset.....	32
Conveyor Runout:.....	32
Navigation buttons .....	32
Speed Control.....	33
Material Control .....	33
Heat & Cool .....	34
Fluid Level .....	34
Solenoid valves.....	34
Alarm Acknowledge / Alarm Reset.....	35
Alarm Ban Setpoint.....	35
Navigation buttons .....	35
Numerical Display .....	36
Temperature Control.....	37
Fluid Level Control .....	37
PH Control .....	37
SERVICE MODE .....	38

## GENERAL

This chapter covers the use and operation of the electrical controls package supplied with your Chemcut processing system. This processing system utilizes a PLC based control package with a Panelview Operator Interface Panel (OIP). The OIP is a touch screen graphical interface with custom designed screens for efficient and user-friendly operation.

The OIP is typically mounted in the door of the electrical enclosure, or optionally mounted on the input or output of the processing system. In addition to the OIP, a MANUAL/AUTO key switch, START and STOP pushbuttons, and EMERGENCY STOP controls are provided. The operations of these controls are described below.

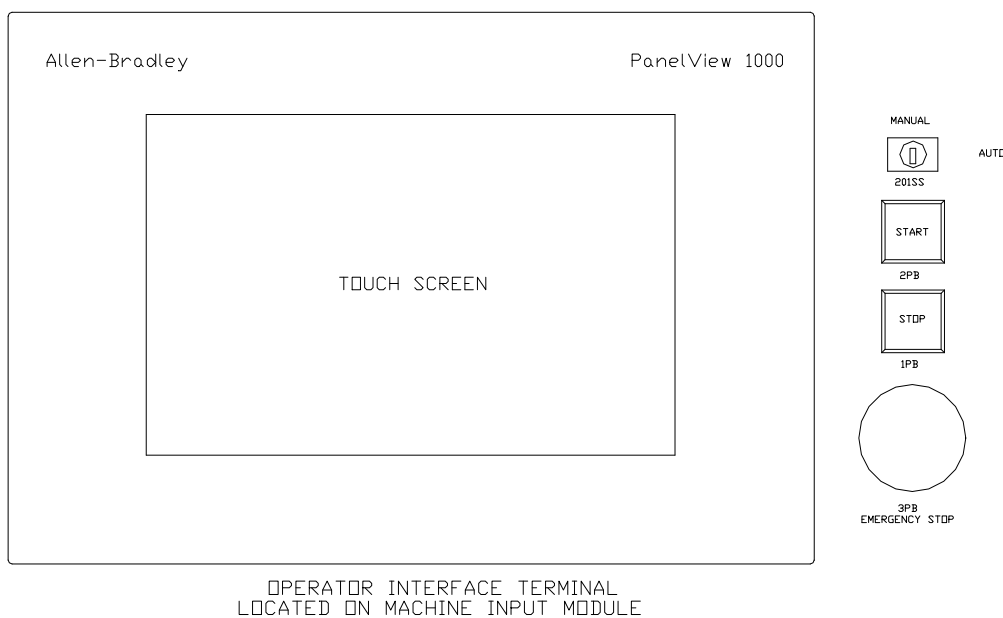

### Manual / Auto Key Switch

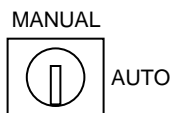

The MANUAL/AUTO key switch selects the operating mode. In the MANUAL mode, individual pumps and heaters may be configured for either an ON or OFF state and parameters such as temperature and conveyor speed are adjustable. In the AUTO mode configuring of pumps and heaters and the adjustment of process parameters is restricted.

## Start / Stop Pushbuttons



The START and STOP pushbuttons are used to start and stop the line. After the line is configured using the OIP, pressing START will apply power to all the configured devices provided that no interlocks (alarms) are present. The STOP button removes power from configured devices. A STOP condition is automatically triggered in the event of an interlock (alarm).

## Emergency Stop

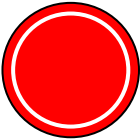

The EMERGENCY STOP pushbutton is to be used should an event require that all machine motion must stop immediately and/or it is necessary to remove hazardous voltage from the machine. EMERGENCY STOP should not be used as a normal machine shutdown as it may interfere with time out sequences designed to remove excess heat from the machine prior to shut down. The STOP button should be used for normal machine shutdown.

## Overview Screen General

The SYSTEM OVERVIEW screen is the HOME or MAIN screen for the system. This screen provides some overall information on the status of the processing system and serves as the central navigation point for accessing information from all the processing stations.

Navigation from this screen to all the processing stations is accomplished by touching the graphic representation of the processing station. Other navigation buttons and status indicators are explained below:

Normal operational status of a processing station is indicated with yellow text on a gray background as shown by the ETCH CLEANER graphic on the left above. A processing station that is in a WARNING or ALARM state will be indicated with red text on a yellow background as illustrated by the ETCH CLEANER graphic on the right above.

## Alarms

NORMAL operational status for the line is indicated by green status lights as shown above on the left side. FAULT conditions are indicated by red status lights as illustrated by the EMERGENCY STOP light shown on the right side above.

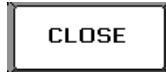

## Navigation buttons



Pressing this button will select the ALARM screen. For further information, refer to the ALARM screen section in this chapter.

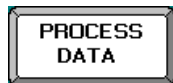

Pressing this button will select the PROCESS DATA screen. For further information, refer to the PROCESS DATA screen section in this chapter.

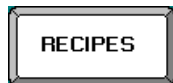

Pressing this button will select the RECIPIES screen. For further information, refer to the RECIPIES screen section in this chapter.

## Pump / Motor Control



OFF

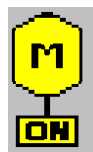

ON

Pump / Motor controls are visualized with two states. In the "OFF" state the graphic is all gray. Pressing on the graphic, causes the control to switch to the "ENABLED" state that is indicated by the graphic turning yellow. Pressing the graphic again causes the graphic to return to the "OFF" state.

## Alarm Acknowledge / Alarm Reset



Pressing this button silences any audible alarm and/or light beacon that was triggered by an Alarm or Warning condition.



Following the repair of the issue that caused the Alarm or Warning condition, pressing this button will clear the Alarm or Warning condition and allow normal machine operation to be re-started.



## Conveyor Runout:



Pressing this button during most ALARM conditions will start the conveyor to permit the operator to exit product from the line. This button only functions during alarm conditions. This button will not function with a conveyor motor overload or Emergency Stop condition present on the line.

## Navigation buttons



Pressing the  steps back one processing station. Pressing the  advances to the next processing station's screen.



Pressing this button will select the ALARM screen. For further information, refer to the ALARM screen section in this chapter.

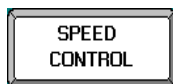

Pressing this button will select the SPEED CONTROL screen. For further information, refer to the SPEED CONTROL screen section below.



Pressing this button will select the MATERIAL CONTROL screen. For further information, refer to the MATERIAL CONTROL screen below.

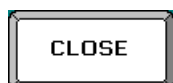

Pressing the "CLOSE" button will close the current screen and return to the previous screen or to the SYSTEM OVERVIEW screen.



## Speed Control

This screen permits the adjustment of the Conveyor Speed Setpoint and the High and Low Warning windows. The SETPOINT field is used to set the conveyor speed. The setpoint is entered by keying in the desired speed in engineering units

Warning High :	#####	in
Setpoint :	#####	in
Warning Low :	#####	in

## Material Control

This screen permits the adjustment of the Total Count and Jam Process.

Pressing any of the three fields on the SPEED CONTROL screen, (SETPOINT:, WARNING HIGH: or WARNING LOW:) causes the following numeric entry screen to appear:

The numeric entry screen consists of a top display area and a keypad. The top display area shows a black bar with '#####' in white, followed by the text 'Enter Value:' and '(##### to #####)'. The keypad is a 5x3 grid with the following layout:

7	8	9
4	5	6
1	2	3
.	0	-
←	↵	

Red arrows point from the text 'BACK KEY' to the left arrow key in the bottom row of the keypad, and from 'RETURN KEY' to the return key in the bottom row of the keypad.

### **IMPORTANT NOTE!**

A default value of 0.0 is displayed in the top window every time the numeric entry screen is accessed. Pressing the RETURN key prior to entering a new value, will send the value 0.0 to the PLC. The PLC will then default to the minimum value for the parameter. **It is important to always enter the desired value prior to pressing the RETURN key.** To exit the numeric entry screen without changing current values, use the BACK key prior to pressing any other keys.

To change the parameter value, simply key in the desired value using the numeric entry keypad. For example, to enter a SETPOINT of 120.0 IPM, key in 120.0 followed by the ENTER key. Values to be entered, must be between the minimum and maximum values that are displayed directly below the top window. Values outside of this range will result in a “value out of range” message.

## Heat & Cool

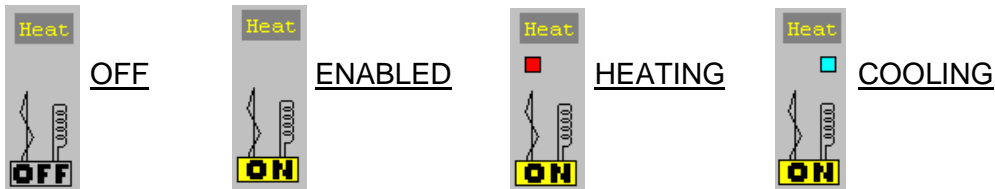

The OFF state for HEATING and COOLING is displayed with a gray “OFF” box. Pressing on the graphic causes the “OFF” box to turn to a yellow “ON” indicating an “ENABLED” state. The actual “HEATING” of the bath will occur when the actual value of the bath temperature is less than the setpoint. The “HEATING” state is indicated with a red box over the graphic representation of the heating element. “COOLING” of the bath will occur when the bath temperature is greater than the setpoint. “COOLING” is indicated with a cyan box over the graphic symbol representing the cooling coil.

## Fluid Level

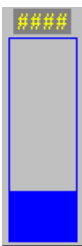

The depth of the fluid in a tank is indicated both numerically and with a bar graph. A digital number representing the depth of the solution is displayed in yellow text on a dark gray background. A blue bar graph represents the percentage the bath is full. A solid blue bar indicates a full bath while a thin bar of blue indicates a bath that is nearly empty.

## Solenoid valves



“OFF” states of solenoid valves are indicated with a gray “OFF” box. When the solenoid is energized, a green “ON” box appears. Some solenoids are illustrated for monitoring purposes only, and cannot be turned ON or OFF from the graphic screen. Nothing will happen when these graphics are pressed. Other solenoids do have the ability to be manually turned ON and OFF from the graphic screen In the “Manual” mode of operation. When these solenoid graphics are pressed in the “MANUAL” operating

mode, the graphic will toggle to the “ON” state. Pressing the graphic again will cause the solenoid to return to the “OFF” state.

## Alarm Acknowledge / Alarm Reset



Pressing this button silences any audible alarm and/or light beacon that was triggered by an Alarm or Warning condition.



Following the repair of the issue that caused the Alarm or Warning condition, pressing this button will clear the Alarm or Warning condition and allow normal machine operation to be re-started.

## Alarm Ban Setpoint



Pressing this button allows the adjustment of the high warning.





Pressing this button allows the setting of the actual setpoint.



Pressing this button allows the adjustment of the low warning.

## Navigation buttons



Pressing the  steps back one processing station. Pressing the  advances to the next processing station's screen.



Pressing this button will select the ALARM screen. For further information, refer to the ALARM screen section in this chapter.

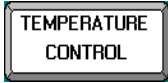

Pressing this button will select the TEMPERATURE CONTROL screen. For further information, refer to the TEPERATURE CONTROL screen section below.



Pressing this button will select the FLUID LEVEL CONTROL screen. For further information, refer to the FLUID LEVEL CONTROL screen below.

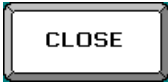

Pressing the "CLOSE" button will close the current screen and return to the previous screen or to the SYSTEM OVERVIEW screen.

## Numerical Display



The parameters above are displayed in engineering unit (inches per minute, degrees F, etc.). They display the actual value of the process parameter (conveyor speed, bath temperature, etc).



## Temperature Control

This screen permits the adjustment of the Temperature / Oscillation Setpoint and the High and Low Warning windows. Pressing any of the three fields on the TEMPERATURE CONTROL and OSCILLATION CONTROL screen, (SETPOINT:, WARNING HIGH: or WARNING LOW:) causes the following numeric entry screen to appear:

Warning High :	#####	°F
Setpoint :	#####	°F
Warning Low :	#####	°F

## Fluid Level Control

This screen permits the adjustment of the Fluid Level Setpoint and the High and Low Warning windows. Pressing any of the three fields on the FLUID LEVEL CONTROL screen, (SETPOINT:, WARNING HIGH: or WARNING LOW:) causes the following numeric entry screen to appear:

## PH Control

This screen permits the adjustment of the PH Control, ORP Control, Specific Gravity Control Setpoint and the High and Low Warning windows. Pressing any of the three fields on the CONTROL screen, (SETPOINT:, WARNING HIGH: or WARNING LOW:) causes the following numeric entry screen to appear:

Process :	#####	ph
Warning High :	#####	ph
Setpoint :	#####	ph
Warning Low :	#####	ph

CYCLE TIMER:		
Process :	###	Sec
Setpoint :	###	Sec



## SERVICE MODE

The SERVICE MODE screen, and following two screens are used for factory and field setup by Chemcut personnel only! They are included in this manual for informational purposes only.

Improper use of these screens can produce improper machine operation resulting in machine damage, site damage, and even personnel injury.

***These screens may only be accessed by qualified individuals under the specific direction of Chemcut personnel.***

ENTER DESIRED FILE NUMBER : #####
ENTER DESIRED WORD NUMBER : #####

ENTER DESIRED SETPOINT VALUE : #####
EXISTING SETPOINT VALUE : #####



## TROUBLESHOOTING / FAULT CODES

CONTENTS.....	Page
<b>6.1 General .....</b>	<b>40</b>
<b>6.2 Malfunctions and Probable Causes.....</b>	<b>41</b>
<b>6.3 System won't start No indicator lights .....</b>	<b>41</b>
<b>6.4 System inoperative Message on Message Display .....</b>	<b>41</b>
6.4.1 Motor Overload .....	41
6.4.2 Fluid Level .....	41
6.4.3 Overtemp.....	41
6.4.4 Lid Open.....	41
6.4.5 Low Water Pressure .....	42
6.4.6 Emergency .....	42
6.4.7 Pump or dryer does not operate.....	42
6.4.8 Conveyor does not operate.....	42
6.4.9 Temperature higher than setpoint .....	42
6.4.10 Temperature lower than setpoint.....	42
6.4.11 Oscillation inoperative .....	43

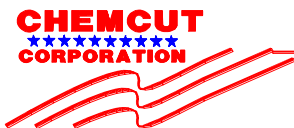

## 6.1 General

The system has its own diagnostic troubleshooting tool, the Message Display. The Message Display not only displays potential problems (warnings), but also when an unexpected malfunction has occurred. It not only displays what the malfunction is (i.e. fluid level motor overload, etc.), but also the process station in the system (i.e. Etch, Strip, Rinse etc.).



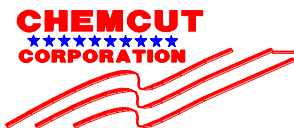

## 6.2 Malfunctions and Probable Causes

The following is a list of possible malfunctions and the probable cause.

### MALFUNCTION

### PROBABLE CAUSE

## 6.3 System won't start No indicator lights

- a. Main Power Switch off
- b. Start button not pushed

## 6.4 System inoperative Message on Message Display

- c. Main power control fuse blown

### 6.4.1 Motor Overload

- a. Motor overload relay tripped
- b. Defective motor

### 6.4.2 Fluid Level

- a. Solution is to low or to high
- b. Float switch hung up
- c. Fluid sensor or switch defective
- d. Supply or drain valve defective

### 6.4.3 Overtemp

- a. Cooling system inoperative See 5
- b. Heating system inoperative See 6
- c. Overtemp probe defective

### 6.4.4 Lid Open

- a. Lid not in place correctly
- b. Lid interlock switch defective

#### **6.4.5 Low Water Pressure**

- a. Water supply turned off or inadequate
- b. Pressure switch defective

#### **6.4.6 Emergency**

- a. Emergency Stop button pushed
- b. Emergency Stop button defective

#### **6.4.7 Pump or dryer does not operate**

- a. Primary fuse(s) blown
- b. Motor starter defective
- c. Motor defective
- d. Clogged filters

#### **6.4.8 Conveyor does not operate**

- a. Control power fuse blown
- b. Broken conveyor gears or coupling
- c. Motor and/or gear head defective
- d. Conveyor printed circuit assembly defective
- e. Interlock condition exists. Conveyor will operate in Runout mode only.

#### **6.4.9 Temperature higher than setpoint**

- a. Cooling water not turned on
- b. Cooling solenoid defective
- c. Heater contactor defective
- d. RTD probe defective
- e. 4 - 20 ma transmitter defective
- f. Exothermic chemical reaction

#### **6.4.10 Temperature lower than setpoint**

- a. Heaters not turned on
- b. Heater fuse(s) blown
- c. Heater contactor defective
- d. RTD probe defective
- e. Cooling solenoid defective
- f. Cooling coil defective



## 6.4.11 Oscillation inoperative

- a. Control power fuse blown
- b. Mechanical linkage loose or disconnected
- c. Motor defective



## 7 PREVENTATIVE MAINTENANCE

Contents.....	Page
<b>7.1 General .....</b>	<b>45</b>
<b>7.2 Schedule phases .....</b>	<b>45</b>
7.2.1 Preventative Maintenance Log.....	46
<b>7.3 Wear items .....</b>	<b>50</b>
7.3.1 Gears.....	50
7.3.2 Bearings .....	50
7.3.3 Couplings.....	50
7.3.4 Nozzles.....	51
7.3.5 Oscillation .....	51
7.3.6 Manifold packing.....	51
7.3.7 Manifold adaptors .....	51
<b>7.4 Consumable parts.....</b>	<b>52</b>
7.4.1 Lamps.....	52
7.4.2 Filters.....	52
7.4.3 Thin material transport.....	52
7.4.4 Drive belts.....	52
7.4.5 Probes .....	52

## 7.1 General

A preventive maintenance program is essential to keep the equipment reliably producing quality product and to ensure that this quality production continues for years into the future. A preventative maintenance program serves two primary purposes.

The first purpose is to maintain the equipment in peak operating condition. Sprockets, bearings, pumps, and other moving parts will wear with time. Periodic inspections are the best way to locate and repair (or replace) worn parts before they cause unwanted down time. It will also remove crystal deposits that accelerate wear on moving parts. Chemcut's history has shown that customers who keep their equipment clean experience much less down time and longer equipment life than those who do not.

The second purpose to avoid unscheduled and unwanted downtime. By replacing worn items at regularly scheduled shut down times, the equipment overall down time will be reduced. This will improve scheduling of production time, with better productivity of the equipment as a result.

The combination of equipment in top operating condition and improved productivity are compelling reasons to institute a preventative maintenance program and to maintain this program throughout the life of the equipment. With a strong focus on preventative maintenance, Chemcut is confident that the equipment will provide a long and profitable life.

## 7.2 Schedule phases

The schedules and procedures for the recommended preventive maintenance program are broken down into phases based on time. The terms used, and a short description for each of these phases are shown below:

- Daily (every 8 hours of operation)
- Weekly (every 40 hours of operation)
- Monthly (every 160 hours of operation)
- Quarterly (every 520 hours of operation)
- Semiannually (every 1040 hours of operation)
- Annually (every 2080 hours of operation)
- Overhaul (after 3-5 years of operation)

## 7.2.1 Preventative Maintenance Log

Any good preventive maintenance program includes the keeping of a P.M. logbook. Blank sample pages of a logbook are included in the following pages. Each page is for a one-month period. Blanks are provided on the sheets to record the system serial number and the month / year. These P.M. records should be kept in chronological order in a common binder or file. P.M., maintenance, and service records should be kept for the entire life of the equipment.

The first sample page is for the Daily and Weekly checks to be performed. It is recommended that the person performing the P.M. check, sign their first initial and last name. This provides an audit trail to ensure that the P.M. procedure is being performed and is being done correctly.

The second page is very similar to the first, except it is for the remaining P.M. checks, (Monthly, Quarterly, Semi-annually, & Annually). This second page also includes "Date Scheduled" fields to assist in planning the dates to perform the Monthly, Quarterly, Semi-annual, & Annual maintenance tasks.

Finally; in conjunction with the P.M. log, a Service / Repair Log should be maintained. This provides another checkpoint as to the actual performance of the system. This log should contain the date of any malfunction, the corrective action taken, and any problems encountered with the corrective action.

A blank sample of the type of Service / Repair log is also included on the following pages. A description of the columns follows.

INCIDENT NUMBER - Used for reference purposes.

DATE PROBLEM - Month/day/year problem occurred.

MODULE/PROBLEM - Module that problem occurred in/on and a brief description of the problem.

ACTION TAKEN – A brief description of corrective action that was taken to correct the problem.

DATE/WHO CORRECTED - Month/day/year that corrective action was completed and the name of the individual that conducted the repair.

These P.M. and Service/Repair logs are an important tool to learn from past failures, and to plan future maintenance and service activities. Proper use of these logs, will result in increased production and will maximize the productive life of the equipment.



Serial #: \_\_\_\_\_ Month/Year: \_\_\_\_/\_\_\_\_

**Daily PM Log:** These procedures are to be conducted daily. After completing the procedure, Initial this log under the correct day of the month.

	P.M.	1 <sup>st</sup>	2 <sup>nd</sup>	3 <sup>rd</sup>	4 <sup>th</sup>	5 <sup>th</sup>	6 <sup>th</sup>	7 <sup>th</sup>
WEEK 1	D-1							
	D-2							
	D-3							
	D-4							
	P.M.	8 <sup>th</sup>	9 <sup>th</sup>	10 <sup>th</sup>	11 <sup>th</sup>	12 <sup>th</sup>	13 <sup>th</sup>	14 <sup>th</sup>
WEEK 2	D-1							
	D-2							
	D-3							
	D-4							
	P.M.	15 <sup>th</sup>	16 <sup>th</sup>	17 <sup>th</sup>	18 <sup>th</sup>	19 <sup>th</sup>	20 <sup>th</sup>	21 <sup>st</sup>
WEEK 3	D-1							
	D-2							
	D-3							
	D-4							
	P.M.	22 <sup>nd</sup>	23 <sup>rd</sup>	24 <sup>th</sup>	25 <sup>th</sup>	26 <sup>th</sup>	27 <sup>th</sup>	28 <sup>th</sup>
WEEK 4	D-1							
	D-2							
	D-3							
	D-4							
	P.M.	29 <sup>th</sup>	30 <sup>th</sup>	31 <sup>st</sup>				
WEEK 5	D-1							
	D-2							
	D-3							
	D-4							

**Weekly PM Log:** These procedures are to be completed weekly. After completing the procedure, date and initial under the proper procedure number.

	W-1	W-2	W-3	W-4	W-5	W-6	W-7	W-8
WEEK 1								
WEEK 2								
WEEK 3								
WEEK 4								
WEEK 5								



Serial #: \_\_\_\_\_ Month/Year: \_\_\_\_/\_\_\_\_

**Monthly PM Log:** These procedures are to be completed monthly. After completing the procedure, date and initial under the proper procedure number.

Procedure	Date Scheduled	Date Completed	Individual who completed P.M.
M1			
M2			
M3			
M4			

**Quarterly PM Log:** These procedures are to be completed quarterly. After completing the procedure, date and initial under the proper procedure number.

Procedure	Date Scheduled	Date Completed	Individual who completed P.M.
Q1			
Q2			

**Semi-annual PM Log:** This procedure is to be completed semi-annually. After completing, date and initial below.

Procedure	Date Scheduled	Date Completed	Individual who completed P.M.
S1			

**Annual PM Log:** These procedures are to be completed annually. After completing the procedure, date and initial under the proper procedure number.

Procedure	Date Scheduled	Date Completed	Individual who completed P.M.
A1			
A2			



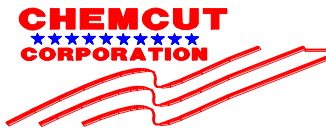

**Serial #:** \_\_\_\_\_ **Repair and Service Log**

<b>Incident Number</b>	<b>Date Problem</b>	<b>Module/ Problem</b>	<b>Corrective Action Taken</b>	<b>Date / Who Corrected</b>

## 7.3 Wear items

The following items are considered as normal wear items and are not covered under the one-year/2000 hour equipment warranty. These items should be included in a recommended spare parts package and are to be maintained in the customer's spare parts inventory.

The replacement frequency of wear items is dependent on a variety of factors, such as, the type of chemistries used, the type of material transported, the conveyor speed, operator skill, and the seriousness with which a preventive maintenance program is established.

Preventive maintenance calls for periodic inspections of the systems components. Wear items are to be inspected at recommended time intervals and replaced as necessary. Replacing such parts before they fail will prevent system failure during normal use.

NOTE: Preventive maintenance procedures are based on hours of system operation. You may wish to change the frequency of the inspections after you have gained sufficient experience with your particular system. The following is recommended.

### 7.3.1 Gears

Gears are to be inspected in accordance with maintenance procedure W-6.

### 7.3.2 Bearings

Side rail bearings will deteriorate over time, depending on the chemistry encountered, the conveyor speed and hours of operation. Wear will be obvious, if present. Check along with procedure W-6.

### 7.3.3 Couplings

Check the couplings between modules in accordance with maintenance procedure W-6.

### **7.3.4 Nozzles**

Nozzles have a dramatic effect on the process of some materials. Other processes are very forgiving in respect to clogged and worn nozzles. Check nozzles in accordance with maintenance procedure D-1.

### **7.3.5 Oscillation**

The moving parts of the oscillation assembly wear and are to be inspected in accordance with maintenance procedure M-5.

### **7.3.6 Manifold packing**

The packing life depends on hours of operation, conveyor speed and the chemistry used. Inspect in accordance with maintenance procedure M-5.

### **7.3.7 Manifold adaptors**

The manifold adapter life depends on the hours of operation, conveyor speed, and the chemistry used. Inspect in accordance with maintenance procedure M-5.

## **7.4 Consumable parts**

The following items are considered as consumable items and are not covered under the one-year/2000 hour equipment warranty. These items should be included in a recommended spare parts package and are to be maintained in the customer's spare parts inventory.

### **7.4.1 Lamps**

Lamps (light bulbs) are considered as consumable items and are to be replaced as needed and inspected in accordance with maintenance procedure S-2.

### **7.4.2 Filters**

Air and water filters are considered as consumable items and are to be replaced as required. These items are to be inspected in accordance with maintenance procedures W-1 and W-2.

### **7.4.3 Thin material transport**

The fingers and associated parts used in thin material packages are considered as consumable items. These items are to be inspected in accordance with maintenance procedure W-6.

### **7.4.4 Drive belts**

Belts are considered as consumable items. These items are to be inspected in accordance with maintenance procedure M-2.

### **7.4.5 Probes**

PH probes and ORP probes will deteriorate over time. These items are to be calibrated periodically and replaced as necessary.

## 8 Maintenance and Adjustment Information

Contents.....		Page
<b>8.1</b>	<b>PREVENTIVE MAINTENANCE CHECKS .....</b>	<b>55</b>
8.1.1	EVERY 8 HOURS.....	55
8.1.2	EVERY 40 HOURS.....	55
8.1.3	EVERY 160 HOURS.....	55
8.1.4	EVERY 1040 HOURS.....	56
8.1.5	EVERY 2080 HOURS.....	56
<b>8.2</b>	<b>MAINTENANCE PROCEDURE – D-1 .....</b>	<b>57</b>
8.2.1	Check nozzle spray pattern.....	57
<b>8.3</b>	<b>MAINTENANCE PROCEDURE – D-2 .....</b>	<b>58</b>
8.3.1	Clean internal filters .....	58
<b>8.4</b>	<b>MAINTENANCE PROCEDURE – D-3 .....</b>	<b>59</b>
8.4.1	Check external filter .....	59
<b>8.5</b>	<b>MAINTENANCE PROCEDURE – D-4 .....</b>	<b>60</b>
8.5.1	Clean exterior of module.....	60
<b>8.6</b>	<b>MAINTENANCE PROCEDURE – W-1 .....</b>	<b>61</b>
8.6.1	Replace in line water filters .....	61
<b>8.7</b>	<b>MAINTENANCE PROCEDURE – W-2 .....</b>	<b>62</b>
8.7.1	Replace air filter on dryer.....	62
<b>8.8</b>	<b>MAINTENANCE PROCEDURE – W-3 .....</b>	<b>63</b>
8.8.1	Check interior of module for cleanliness.....	63
<b>8.9</b>	<b>MAINTENANCE PROCEDURE – W-4 .....</b>	<b>64</b>
8.9.1	Check PH .....	64
<b>8.10</b>	<b>MAINTENANCE PROCEDURE – W-5 .....</b>	<b>65</b>
8.10.1	Clean baume stand pipes .....	65
<b>8.11</b>	<b>MAINTENANCE PROCEDURE – W-6 .....</b>	<b>66</b>
8.11.1	Inspect gear train .....	66
<b>8.12</b>	<b>MAINTENANCE PROCEDURE – W-7 .....</b>	<b>67</b>
8.12.1	Inspect fluid head.....	67
<b>8.13</b>	<b>MAINTENANCE PROCEDURE – W-8 .....</b>	<b>68</b>
8.13.1	Inspect flood bar .....	68
<b>8.14</b>	<b>MAINTENANCE PROCEDURE – M-1.....</b>	<b>69</b>
8.14.1	Check conveyor drive belts .....	69
<b>8.15</b>	<b>MAINTENANCE PROCEDURE – M-2.....</b>	<b>70</b>
8.15.1	Check alignment of spray tubes.....	70
<b>8.16</b>	<b>MAINTENANCE PROCEDURE – M-3.....</b>	<b>71</b>
8.16.1	Check plumbing for leaks.....	71
<b>8.17</b>	<b>MAINTENANCE PROCEDURE – M-4.....</b>	<b>72</b>
8.17.1	Inspect oscillation system .....	72
<b>8.18</b>	<b>MAINTENANCE PROCEDURE – Q-1 .....</b>	<b>73</b>
8.18.1	Inspect oscillation system .....	73
<b>8.19</b>	<b>MAINTENANCE PROCEDURE – Q-2.....</b>	<b>74</b>
8.19.1	Inspect control panel.....	74



<b>8.20</b>	<b>MAINTENANCE PROCEDURE – S-1</b> .....	<b>75</b>
8.20.1	Inspect junction boxes.....	75
<b>8.21</b>	<b>MAINTENANCE PROCEDURE – A-1</b> .....	<b>76</b>
8.21.1	Inspect pumps.....	76
<b>8.22</b>	<b>MAINTENANCE PROCEDURE – A-2</b> .....	<b>78</b>
8.22.1	Inspect blower motor.....	78
<b>8.23</b>	<b>MAINTENANCE PROCEDURE – O-1</b> .....	<b>79</b>
8.23.1	Overhaul Equipment .....	79

## 8.1 PREVENTIVE MAINTENANCE CHECKS

The following checks are to be performed on a predetermined schedule based on hours of operation of the system. You may need to adjust the frequency of the inspections after you have gained sufficient experience with your particular system. The following is a quick reference list of checks. Detailed maintenance procedures follow this list.

### 8.1.1 EVERY 8 HOURS

#### EVERY 8 HOURS

- CHECK NOZZLES
- CHECK INTERNAL FILTERS
- CHECK EXTERNAL FILTERS
- CLEAN EXTERIOR OF MODULES

### 8.1.2 EVERY 40 HOURS

#### EVERY 40 HOURS

- REPLACE WATER FILTERS
- REPLACE AIR FILTERS
- CLEAN INTERIOR OF MODULES
- CHECK PH
- CLEAN BAUME STAND PIPE
- INSPECT CONVEYOR GEARS
- INSPECT FLUIDHEADS
- INSPECT FLOODBARS

### 8.1.3 EVERY 160 HOURS

#### EVERY 160 HOURS

- CHECK CONVEYOR BELTS
- CHECK SPRAY TUBE ALIGNMENT
- CHECK PLUMBING
- INSPECT OSCILLATION

## **8.1.4 EVERY 1040 HOURS**

### EVERY 1040 HOURS

- CHECK INTERLOCKS
- INSPECT CONTROL PANEL

## **8.1.5 EVERY 2080 HOURS**

### EVERY 2080 HOURS

- INSPECT JUNCTION BOXES
- INSPECT PUMPS
- INSPECT BLOWERS



## 8.2 MAINTENANCE PROCEDURE – D-1

### 8.2.1 Check nozzle spray pattern

**PROCEDURE:** Check nozzle spray pattern - clean nozzles as necessary.

**FREQUENCY:** Every 8 hours of operation.

**TOOLS REQUIRED:** Screwdriver, needle nosed pliers, wrench, air hose.

**SAFETY REQUIREMENTS:** Eye protection is to be worn at all times. Wear appropriate protective clothing (gloves, apron, etc.) when working near modules containing hazardous chemistries. Use a respirator if a high concentration of fumes is present.

**TIME REQUIRED:** .03 man hours to inspect. .03 man hours per clogged nozzle.

#### **PROCEDURE STEPS:**

1. Visually inspect the spray pattern by looking through the cover and/or doors of the module. It may be necessary to alternately turn off the upper and lower sprays to see the pattern.

If clogged nozzles have been observed:

2. Turn off the module.
3. Remove cover, or, door to gain access to the clogged nozzle.
4. Remove the clogged nozzle.
5. Remove the insert from the nozzle.
6. Blow compressed air through the nozzle to clean. Soak the nozzle in cleaning solution first, if required.) Do not use wire or scrape the nozzle to remove debris as this will damage the orifice.
7. Replace the nozzle(s) and cover(s).

**NOTE:** If nozzles are frequently clogged, check for contaminated chemistry, clogged filters, etc.

## 8.3 MAINTENANCE PROCEDURE – D-2

### 8.3.1 Clean internal filters

**PROCEDURE:** Clean internal filters.

**FREQUENCY:** Every 8 hours of operation.

**TOOLS REQUIRED:** Screwdriver.

**SAFETY REQUIREMENTS:** Eye protection is to be worn at all times. Wear appropriate protective clothing (gloves, apron, etc.,) when working near modules containing hazardous chemistries. Use a respirator if a high concentration of fumes is present.

**TIME REQUIRED:** .03 man hours.

**PROCEDURE STEPS:**

1. Turn off module.
2. Remove the sump cover, door, etc., as required to gain access to the filter.
3. Remove the filter from the module.
4. Clean the filter, removing any collected residue.
5. Replace the filter.
6. Replace the sump cover, door, etc.

## 8.4 MAINTENANCE PROCEDURE – D-3

### 8.4.1 Check external filter

**PROCEDURE:** Check external filter.

**FREQUENCY:** Every 8 hours of operation.

**TOOLS REQUIRED:** Screwdriver.

**SAFETY REQUIREMENTS:** Eye protection is to be worn at all times. Wear appropriate protective clothing (gloves, apron, etc.,) when working near modules containing hazardous chemistries. Use a respirator if a high concentration of fumes is present.

**TIME REQUIRED:** .01 man hours. .05 if filter is changed.

**PROCEDURE STEPS:**

1. Visually inspect the filter.  
If Required:
2. Remove the dirty filter.
3. Install a new filter.

**NOTE:** The frequency of filter replacement may require it be changed either more or less often.

## 8.5 MAINTENANCE PROCEDURE – D-4

### 8.5.1 Clean exterior of module

**PROCEDURE:** Clean exterior of module.

**FREQUENCY:** Every 8 hours of operation.

**TOOLS REQUIRED:** Soft bristle scrub brush, water hose, air hose.

**SAFETY REQUIREMENTS:** Eye protection is to be worn at all times. Wear appropriate protective clothing (gloves, apron, etc.) when working near modules containing hazardous chemistries. Use a respirator if a high concentration of fumes is present.

**TIME REQUIRED:** .03 man hours.

**PROCEDURE STEPS:**

1. Turn off module.
2. Clean the exterior of the module using brush and water. Remove all crystal deposits
3. Blow off excess water with the air hose.

**NOTE:** Avoid spraying water directly on pump motors and electrical connections.

## 8.6 MAINTENANCE PROCEDURE – W-1

### 8.6.1 Replace in line water filters

**PROCEDURE:** Replace in line water filters (as required.)

**FREQUENCY:** Every 40 hours of operation.

**TOOLS REQUIRED:** None.

**SAFETY REQUIREMENTS:** Eye protection is to be worn at all times. Wear appropriate protective clothing (gloves, apron, etc.) when working near modules containing hazardous chemistries. Use a respirator if a high concentration of fumes is present.

**TIME REQUIRED:** .01 man hours to inspect. .03 man hours to replace.

**PROCEDURE STEPS:**

1. Visually inspect the filter cartridge.
2. If the filter is to be replaced, turn off the input water valve.
3. Remove the filter.
4. Replace the filter.

**NOTE:** The frequency of filter replacement may require it be changed either more or less often.

## 8.7 MAINTENANCE PROCEDURE – W-2

### 8.7.1 Replace air filter on dryer

**PROCEDURE:** Replace air filter on dryer (as required.)

**FREQUENCY:** Every 40 hours of operation.

**TOOLS REQUIRED:** Flat blade screwdriver.

**SAFETY REQUIREMENTS:** Eye protection is to be worn at all times. Wear appropriate protective clothing (gloves, apron, etc.) when working near modules containing hazardous chemistries. Use a respirator if a high concentration of fumes is present.

**TIME REQUIRED:** .02 man hours.

**PROCEDURE STEPS:**

1. Turn off module.
2. Remove the air filter and inspect - replace as required.
3. Reinstall the filter.

**NOTE:** The frequency of filter replacement may require it be changed either more or less often.

## 8.8 MAINTENANCE PROCEDURE – W-3

### 8.8.1 Check interior of module for cleanliness

**PROCEDURE:** Check interior of module for cleanliness (clean as required.)

**FREQUENCY:** Every 40 hours of operation.

**TOOLS REQUIRED:** Soft bristle scrub brush, bottle brush, water hose, air hose.

**SAFETY REQUIREMENTS:** Eye protection is to be worn at all times. Wear appropriate protective clothing (gloves, apron, etc.) when working near modules containing hazardous chemistries. Use a respirator if a high concentration of fumes is present.

**TIME REQUIRED:** .1 man hours

#### **PROCEDURE STEPS:**

1. Turn off system.
2. Drain solution from module.
3. Remove lids, doors, to gain access to inside of the module.
4. Rinse out interior of module. Remove all crystal growth with a scrub brush.
5. Clean deposits from doors, lids and sealing surfaces.
6. Clean gear train with a bottle brush.
7. Rinse out module.
8. Replace doors and lids.

**NOTE:** The frequency of cleaning depends on the type and condition of the chemistry used in the module.

## 8.9 MAINTENANCE PROCEDURE – W-4

### 8.9.1 Check PH

**PROCEDURE:** Check PH. Use buffer solution to check accuracy of probes.

**FREQUENCY:** Every 40 hours of operation.

**TOOLS REQUIRED:** Buffer solution.

**SAFETY REQUIREMENTS:** Eye protection is to be worn at all times. Wear appropriate protective clothing (gloves, apron, etc.) when working near modules containing hazardous chemistries. Use a respirator if a high concentration of fumes is present.

**TIME REQUIRED:** .15 man hours

#### **PROCEDURE STEPS:**

1. Turn off module.
2. Remove ph probe from its housing assembly.
3. Wash probe with deionize water.
4. Immerse ph probe in a buffer solution of a known value.
5. Standardize if required.
6. Reinstall probe into its housing.



## 8.10 MAINTENANCE PROCEDURE – W-5

### 8.10.1 Clean baume stand pipes

**PROCEDURE:** Clean baume stand pipes - readjust flow, as required.

**FREQUENCY:** Every 40 hours of operation.

**TOOLS REQUIRED:** Commercial glass cleaner and soft rags.

**SAFETY REQUIREMENTS:** Eye protection is to be worn at all times. Wear appropriate protective clothing (gloves, apron, etc.,) when working near modules containing hazardous chemistries. Use a respirator if a high concentration of fumes is present.

**TIME REQUIRED:** .03 man hours.

**PROCEDURE STEPS:**

1. Turn off module.
2. Remove the baume standpipe and clean with a soft rag.
3. Reinstall the baume standpipe.
4. Turn on the module and readjust flow, as required.

## 8.11 MAINTENANCE PROCEDURE – W-6

### 8.11.1 Inspect gear train

**PROCEDURE:** Inspect gear train. Replace worn gears, as required.

**FREQUENCY:** Every 40 hours of operation.

**TOOLS REQUIRED:** Flat blade screwdriver.

**SAFETY REQUIREMENTS:** Eye protection is to be worn at all times. Wear appropriate protective clothing (gloves, apron, etc.,) when working near modules containing hazardous chemistries. Use a respirator if a high concentration of fumes is present.

**TIME REQUIRED:** .03 man hours.

**PROCEDURE STEPS:**

1. Turn off module.
2. Remove covers/doors, to gain access to module gear train.
3. Inspect all gears, checking for proper gear mesh and worn teeth.
4. Notify maintenance personnel of any gear wear or other flaws.

**NOTE:** Obvious flaws need to be corrected right away. Minor irregularities may wait until the next scheduled PM. All flaws should be reported to maintenance personnel when observed.

## 8.12 MAINTENANCE PROCEDURE – W-7

### 8.12.1 Inspect fluid head

**PROCEDURE:** Inspect fluid head. Clean if necessary.

**FREQUENCY:** Every 40 hours of operation.

**TOOLS REQUIRED:** Screwdriver, adjustable wrench, low pressure air, vacuum suction

**SAFETY REQUIREMENTS:** Eye protection is to be worn at all times. Wear appropriate protective clothing (gloves, apron, etc.) when working near modules containing hazardous chemistry. Use a respirator if a high concentration of fumes is present..

**TIME REQUIRED:** 1.0 man hours

#### **PROCEDURE STEPS:**

1. While machine is in operation, look through covers and see if any fluid heads are clogged. Note the location of any that are.
2. Turn off the module.
3. Remove covers.
4. Use clean compressed air, aimed at the injector holes with vacuum suction to the plenum fitting. If necessary, use a narrow diameter quill to clear debris from the injector holes, being careful not to deform the orifice of the holes.
5. Replace covers.

## 8.13 MAINTENANCE PROCEDURE – W-8

### 8.13.1 Inspect flood bar

**PROCEDURE:** Inspect flood bar. Clean if necessary.

**FREQUENCY:** Every 40 hours of operation..

**TOOLS REQUIRED:** Screwdriver, adjustable wrench, low pressure air.

**SAFETY REQUIREMENTS:** Eye protection is to be worn at all times. Wear appropriate protective clothing (gloves, apron, etc.) when working near modules containing hazardous chemistry. Use a respirator if a high concentration of fumes is present..

**TIME REQUIRED:** 1.0 man hours

#### **PROCEDURE STEPS:**

1. While machine is in operation, look through covers and see if any flood bars are clogged. Note the location of any that are.
2. Turn off the module.
3. Remove covers.
4. Remove either blade of clogged flood bar to clean slot of flood bar.
5. Replace covers.

**NOTE:** Do not use a piece of wire or any sharp object to clean flood bar. This will deform the flood bar slot and change the flooding characteristics of the flood bar.

## 8.14 MAINTENANCE PROCEDURE – M-1

### 8.14.1 Check conveyor drive belts

**PROCEDURE:** Check conveyor drive belts. Adjust, or, replace as necessary.

**FREQUENCY:** Every 160 hours of operation.

**TOOLS REQUIRED:** Flat blade screwdriver, adjustable wrench.

**SAFETY REQUIREMENTS:** Eye protection is to be worn at all times. Wear appropriate protective clothing (gloves, apron, etc.,) when working near modules containing hazardous chemistries. Use a respirator if a high concentration of fumes is present.

**TIME REQUIRED:** .05 man hours to inspect. .1 man hours to replace.

#### **PROCEDURE STEPS:**

1. Turn off the module.
2. Remove the cover to gain access to the drive belt.
3. Check the belt and sprocket for alignment and wear. Replace the belt, if necessary.
4. Reassemble the unit.

## 8.15 MAINTENANCE PROCEDURE – M-2

### 8.15.1 Check alignment of spray tubes

**PROCEDURE:** Check alignment of spray tubes (developers and etchers,) adjust as necessary.

**FREQUENCY:** Every 160 hours of operation.

**TOOLS REQUIRED:** Flat blade screwdriver, adjustable wrench.

**SAFETY REQUIREMENTS:** Eye protection is to be worn at all times. Wear appropriate protective clothing (gloves, apron, etc.,) when working near modules containing hazardous chemistries. Use a respirator if a high concentration of fumes is present.

**TIME REQUIRED:** .08 man hours.

**PROCEDURE STEPS:**

1. Remove the module doors.
2. Check the alignment of the spray tubes.
3. Make any adjustments, as required.
4. Replace the module doors.

\* This procedure may be accomplished in conjunction with M-4 (Inspect oscillation system).

## 8.16 MAINTENANCE PROCEDURE – M-3

### 8.16.1 Check plumbing for leaks

**PROCEDURE:** Check plumbing for leaks. Tighten as necessary.

**FREQUENCY:** Every 160 hours of operation.

**TOOLS REQUIRED:** Flat blade screwdriver, thread tape, strap wrench.

**SAFETY REQUIREMENTS:** Eye protection is to be worn at all times. Wear appropriate protective clothing (gloves, apron, etc.) when working near modules containing hazardous chemistries. Use a respirator if a high concentration of fumes is present.

**TIME REQUIRED:** .04 man hours.

#### **PROCEDURE STEPS:**

1. With the module running, inspect for leaks of the plumbing.
  - Unusual sounds.
  - Low pump pressure.
  - Unusual spray pattern on door or top cover.
2. Locate the source of any leaks.
3. Turn off the module and repair any leaks.
4. Turn the module on and re-inspect for any additional leaks.

## 8.17 MAINTENANCE PROCEDURE – M-4

### 8.17.1 Inspect oscillation system

**PROCEDURE:** Inspect oscillation system. Check shoulder bolts of the oscillation for tightness. Inspect manifold seals for leakage.

**FREQUENCY:** Every 160 hours of operation.

**TOOLS REQUIRED:** Flat blade screwdriver, adjustable wrench.

**SAFETY REQUIREMENTS:** Eye protection is to be worn at all times. Wear appropriate protective clothing (gloves, apron, etc.,) when working near modules containing hazardous chemistries. Use a respirator if a high concentration of fumes is present.

**TIME REQUIRED:** .06 man hours.

#### **PROCEDURE STEPS:**

1. With the module operating:
  - Check for proper spray pressure.
  - Check for any unusual sounds.
  - Check for unusual spray pattern on the doors, or, top cover.
2. Turn the module off and remove the module doors.
3. Check the shoulder bolts in the oscillation pivot blocks for tightness.
4. Check the oscillation movement for smooth operation.
5. Check the oscillation drive motor v-seal and packing for leakage.
6. Reassemble the module.



## 8.18 MAINTENANCE PROCEDURE – Q-1

### 8.18.1 Inspect oscillation system

**PROCEDURE:** Check interlock functions (door, fluid level, etc.) Repair/adjust as necessary. Check emergency stop switches.

**FREQUENCY:** Every 1040 hours of operation.

**TOOLS REQUIRED:** Flat blade screwdriver.

**SAFETY REQUIREMENTS:** Eye protection is to be worn at all times. Wear appropriate protective clothing (gloves, apron, etc.) when working near modules containing hazardous chemistries. Use a respirator if a high concentration of fumes is present.

**TIME REQUIRED:** .3 man hours.

#### **PROCEDURE STEPS:**

1. Turn off pump (if applicable) and check lid interlock by removing the lid. Insure that interlock occurs. Repair/replace defective interlocks.
2. Remove sump lid to gain access to fluid level interlocks. Move switches up and down to check high and low level interlocks. Insure that the proper interlock occurs.
3. Check pressure switches. Turn off air supply and insure that interlock occurs. Turn off water supply and insure that interlock occurs.
4. Reassemble the module.

\* This procedure may be accomplished in conjunction with S-2. Inspect control panel and functions.

## 8.19 MAINTENANCE PROCEDURE – Q-2

### 8.19.1 Inspect control panel

**PROCEDURE:** Inspect control panel (s.) Inspect all functions. Replace bulbs, switches, etc., as necessary.

**FREQUENCY:** Every 1040 hours of operation.

**TOOLS REQUIRED:** Flat blade screwdriver.

**SAFETY REQUIREMENTS:** Eye protection is to be worn at all times. Wear appropriate protective clothing (gloves, apron, etc.,) when working near modules containing hazardous chemistries. Use a respirator if a high concentration of fumes is present.

**TIME REQUIRED:** .1 man hours.

#### PROCEDURE STEPS:

1. Check all operator controls for proper function.
  - Turn pumps, conveyor, etc. on/off.
  - Ensure that the proper indicator lights are illuminated.
  - Check all interlocks for proper function.
2. Check all functions of the system. Start the system and check that all operations occur properly in both the manual and auto modes of operation.
3. Replace any burned out indicator lights or defective switches.

\* This procedure may be accomplished in conjunction with S-1 (check interlock functions).

## 8.20 MAINTENANCE PROCEDURE – S-1

### 8.20.1 Inspect junction boxes

**PROCEDURE:** Inspect junction boxes. Check for leakage and/or corrosion. Repair or replace as necessary (terminals, gasket material, etc.)

**FREQUENCY:** Every 2080 hours of operation.

**TOOLS REQUIRED:** Flat blade screwdriver, adjustable wrench.

**SAFETY REQUIREMENTS:** Eye protection is to be worn at all times. Wear appropriate protective clothing (gloves, apron, etc.,) when working near modules containing hazardous chemistries. Use a respirator if a high concentration of fumes is present.

**TIME REQUIRED:** .1 man hours.

#### **PROCEDURE STEPS:**

1. Turn off power to the system.
2. Remove the junction box cover.
3. Inspect the box for signs of corrosion.
  - Check the gasket material. Replace as necessary.
  - Check for leakage.
  - Check for corroded or loose terminals.
4. Tighten and/or repair wiring as necessary.
5. Replace the junction box cover.

## 8.21 MAINTENANCE PROCEDURE – A-1

### 8.21.1 Inspect pumps

**PROCEDURE:** Inspect pumps. Remove pumps and check for damaged components. Replace parts as necessary.

**FREQUENCY:** Every 2080 hours of operation.

**TOOLS REQUIRED:** Flat blade screwdriver, adjustable wrench.

**SAFETY REQUIREMENTS:** Eye protection is to be worn at all times. Wear appropriate protective clothing (gloves, apron, etc.,) when working near modules containing hazardous chemistries. Use a respirator if a high concentration of fumes is present.

**TIME REQUIRED:** One man hour.

**PROCEDURE STEPS:**

1. Turn off power.
2. Remove the pump.
3. Check for damaged and/or worn components. Replace as necessary.
4. Inspect motor for corrosion. (If badly corroded, replacement should be considered.)
5. Reassemble pump. Set impeller clearance to back plate at 0.45".
6. Reassemble module.

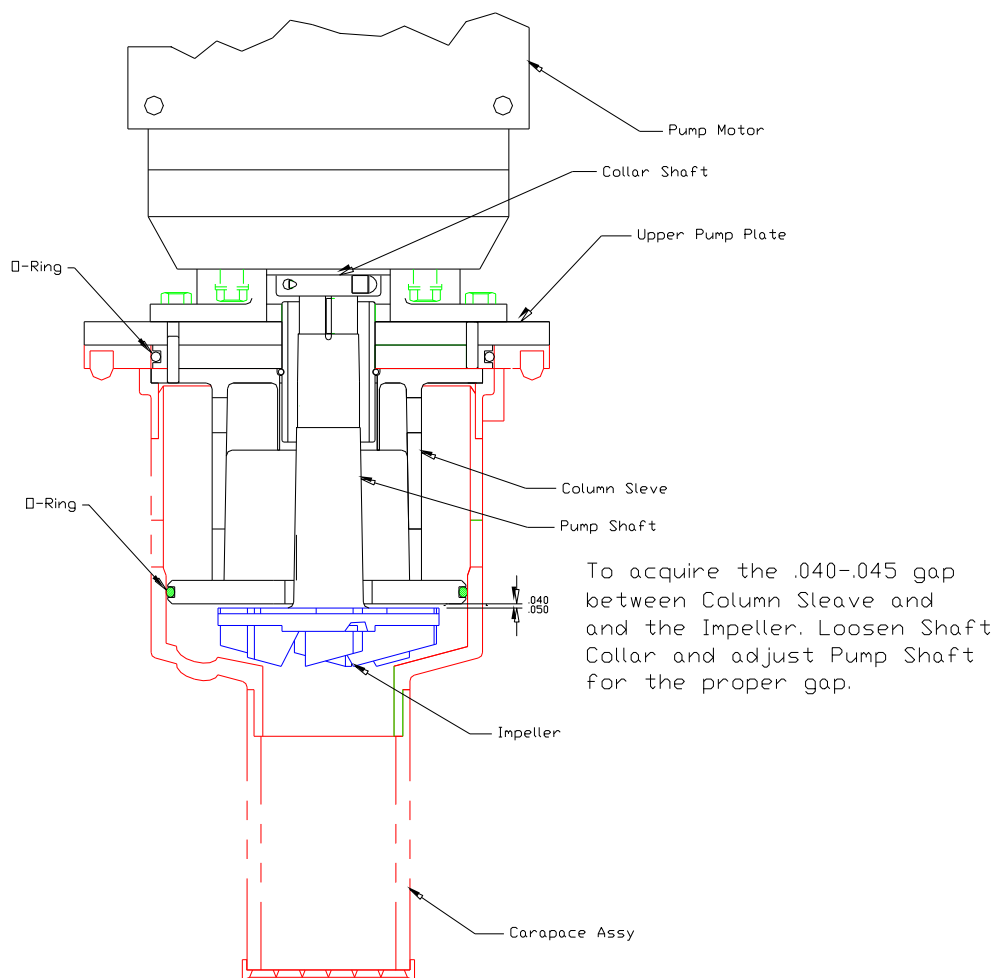

## 8.22 MAINTENANCE PROCEDURE – A-2

### 8.22.1 Inspect blower motor

**PROCEDURE:** Inspect blower motor.

**FREQUENCY:** Every 2080 hours of operation.

**TOOLS REQUIRED:** Flat blade screwdriver.

**SAFETY REQUIREMENTS:** Eye protection is to be worn at all times. Wear appropriate protective clothing (gloves, apron, etc.,) when working near modules containing hazardous chemistries. Use a respirator if a high concentration of fumes is present.

**TIME REQUIRED:** .05 man hours.

#### **PROCEDURE STEPS:**

1. With the blower running, listen for any unusual sounds.
2. Turn off module.
3. Remove the cover to gain access to the blower motor.
4. Inspect the motor. Ensure that the shaft turns freely. Resistance to turning could indicate worn bearings. Replace as necessary.
5. Inspect the belts for wear.
6. Reassemble the module.

## 8.23 MAINTENANCE PROCEDURE – O-1

### 8.23.1 Overhaul Equipment

**PROCEDURE:** Overhaul Equipment

**FREQUENCY:** Every 3 to 5 years of operation.

**TOOLS REQUIRED:** as required

**SAFETY REQUIREMENTS:** Eye protection is to be worn at all times. Wear appropriate protective clothing (gloves, apron, etc.) when working near modules containing hazardous chemistries. Use a respirator if a high concentration of fumes is present.

**TIME REQUIRED:** as required

#### **PROCEDURE STEPS:**

Every three to five years an overhaul should be considered. This would consist of first doing an in-depth cleaning of the equipment. Then the conveyor should be overhauled. Gears, bearings, conveyor siderail inserts, conveyor rods, conveyor wheels, and drive motors should be checked. Any worn or corroded items should be replaced.

Then plumbing systems should be checked. Replace all nozzles, as the orifice in the nozzle will wear slowly. Check all spray tubes, pipes, pumps, valves, etc. Replace or repair leaky fittings or warped spray tubes. Check the spray tube bushings for wear and replace if necessary. Check pumps and motors. Replace all worn or corroded items.

Then check all junction boxes, control panels, etc. Replace all corroded connections and bad electrical parts. Replace any cracked or warped covers.

If you would have questions as to what work would need to be done, Chemcut will gladly audit the equipment, provide an estimate to overhaul the equipment, and explain all items.

## 9 Parts & Spare Parts

Contents.....		Page
<b>9.1</b>	<b>PLE634 Load &amp; Drive</b> .....	<b>82</b>
9.1.1	PLE634M PLE634,MEC PARTS,P-SIGMA.....	82
9.1.2	CNVR,ROLL,PLE634,LR,C60-500.....	83
9.1.3	ROLL,60,2X2,SOLID,LWR,TPN/T.....	85
9.1.4	DRIVE,PLE634,140IPM,TI,C60-500.....	87
<b>9.2</b>	<b>PIA634 Conveyor</b> .....	<b>89</b>
9.2.1	PIA634M PIA634,MEC PARTS,P-SIGMA.....	89
9.2.2	CNVR,ROLL,PIA634,LR,C60-500.....	90
9.2.3	ROLL,60,2X2,SOLID,LWR,TPN/T.....	92
9.2.4	VENT INSTL,P-SIGMA,60".....	94
<b>9.3</b>	<b>POS607 Ferric Chloride Etch</b> .....	<b>96</b>
9.3.1	POS607M-1 POS607,MEC PARTS,NO/AIR SEAL.....	96
9.3.2	POS607 MOD ASSY,NO/AIR SEAL.....	96
9.3.3	MODULE INT,POS607,TI,N/AIRSEAL.....	97
9.3.4	DRIVE INSTL,OSCILLATION,POS607 503097 No Drawing.....	98
9.3.5	SPRAYRACK INSTL,POS607,(40-PG).....	100
9.3.6	SPRAYRACK ASSY,UP/LEFT,POS607.....	102
9.3.7	SPRAYRACK ASSY,LOW/LEFT,POS607.....	104
9.3.8	SPRAYRACK ASSY,UP/RIGHT,POS607.....	106
9.3.9	SPRAYRACK ASSY,LOW/RHGT,POS607.....	108
9.3.10	CNVR,ROLL,POS607,LR,N/OUT ROLL.....	110
9.3.11	ROLL,60,2X2,SOLID,TPN/TI*.....	112
9.3.12	ROLL,60,2X2,SOLID,LWR,TPN/T.....	114
9.3.13	ROD,60,2X2,LWR ONLY,GRAPHITE.....	116
9.3.14	PLUMBING,POS607.....	118
9.3.15	PLUMBING,POS607,LOWER RACK.....	119
9.3.16	PLUMBING,POS607,UPPER RACK.....	121
9.3.17	PLUMBING,POS607,DRAIN.....	123
9.3.18	PUMP SUBASSY,P-55J-C1.....	124
9.3.19	Pump Specifications.....	126
9.3.20	COOLING,POS607.....	127
9.3.21	GAUGE INSTL,POS607,0-60 (40).....	130
9.3.22	GAUGE INSTL,PRESS,PEM,(2).....	132
9.3.23	NOZZLE INSTL,EDGE ETCH.....	134
9.3.24	HEAT,6X6KW,440-480V,TI,M BLD.....	136
9.3.25	JCT BOX INSTL,AIRGAP,POS06.....	138
9.3.26	RECIRC PUMP,(2)POS,3HP,W/FEEDS.....	140
9.3.27	INTERCONNECT,SUMP,POS (4-EA).....	142
9.3.28	SUPPLY,PVC SOL,1/2",POS.....	144
<b>9.4</b>	<b>POS607 Ferric Chloride Etch</b> .....	<b>145</b>
9.4.1	POS607M-1 POS607,MEC PARTS,NO/AIR SEAL.....	145
9.4.2	POS607 MOD ASSY,NO/AIR SEAL.....	145
9.4.3	MODULE INT,POS607,TI,N/AIRSEAL.....	146



9.4.4	DRIVE INSTL,OSCILLATION,POS607 503097 No Drawing	147
9.4.5	SPRAYRACK INSTL,POS607,(40-PG)	149
9.4.6	SPRAYRACK ASSY,UP/LEFT,POS607	151
9.4.7	SPRAYRACK ASSY,LOW/LEFT,POS607	153
9.4.8	SPRAYRACK ASSY,UP/RIGHT,POS607	155
9.4.9	SPRAYRACK ASSY,LOW/RHGT,POS607	157
9.4.10	CNVR,ROLL,POS607,LR,N/OUT ROLL	159
9.4.11	ROLL,60,2X2,SOLID,TPN/TI*	161
9.4.12	ROLL,60,2X2,SOLID,LWR,TPN/T	163
9.4.13	ROD,60,2X2,LWR ONLY,GRAPHITE	165
9.4.14	PLUMBING,POS607	167
9.4.15	PLUMBING,POS607,LOWER RACK	168
9.4.16	PLUMBING,POS607,UPPER RACK	170
9.4.17	PLUMBING,POS607,DRAIN	172
9.4.18	PUMP SUBASSY,P-55J-C1	173
9.4.19	Pump Specifications	175
9.4.20	COOLING,POS607	176
9.4.21	GAUGE INSTL,POS607,0-60 (40)	180
9.4.22	GAUGE INSTL,PRESS,PEM,(2)	182
9.4.23	NOZZLE INSTL,EDGE ETCH	184
9.4.24	HEAT,6X6KW,440-480V,TI,M BLD	186
9.4.25	JCT BOX INSTL,AIRGAP,POS06	188
9.4.26	RECIRC PUMP,(2)POS,3HP,W/FEEDS	190
9.4.27	INTERCONNECT,SUMP,POS (4-EA)	192
9.4.28	SUPPLY,PVC SOL,1/2",POS	194
<b>9.5</b>	<b><u>PIA634 Conveyor</u></b>	<b>195</b>
9.5.1	<a href="#">PIA634M</a> <a href="#">PIA634,MEC PARTS,P-SIGMA</a>	195
9.5.2	CNVR,ROLL,PIA634,LR,C60-500	196
9.5.3	ROLL,60,2X2,SOLID,LWR,TPN/T	198
9.5.4	VENT INSTL,P-SIGMA,60"	200
<b>9.6</b>	<b><u>PRE634 Unload &amp; Drive</u></b>	<b>202</b>
9.6.1	<a href="#">PRE634M</a> <a href="#">PRE634,MEC PARTS,P-SIGMA</a>	202
9.6.2	CNVR,ROLL,PRE634,LR,C60-500	203
9.6.3	ROLL,60,2X2,SOLID,LWR,TPN/T	205
9.6.4	DRIVE,PRE634,140IPM,TI,C60-500	208
<b>9.7</b>	<b><u>General Parts Ordering Instructions</u></b>	<b>211</b>
<b>9.8</b>	<b><u>Parts Ordering Call 1-800-243-6288</u></b>	<b>213</b>
<b>9.9</b>	<b><u>Recommended Spare Parts</u></b>	<b>214</b>

## 9.1 PLE634 Load & Drive

### 9.1.1 PLE634M PLE634,MEC PARTS,P-SIGMA

ITEM_#_ON	DRAWING	PART_NUMBER	DESCRIPTION	QUANTITY
1	503184	CHAMBER,PLE634		1.
3	502770	COVER,SIDERAIL,FRNT,PRE334		1.
7	502771	COVER,SIDERAIL,REAR,PRE334		1.
5	503188	PLENUM,PLE634		1.
6	131644	COVER INSTL,FRONT,33.882		1.
	136187	LABELS,SIGMA,TLE\TRE,STD		1
	503078	DRIVE,PLE634,140IPM,TI,C60-500		1
	503122	CNVR,ROLL,PLE634,LR,C60-500		1
	503164	DRAIN BACK,PLE/PRE-PIA-POS,1"		1

### 9.1.2 CNVR,ROLL,PLE634,LR,C60-500

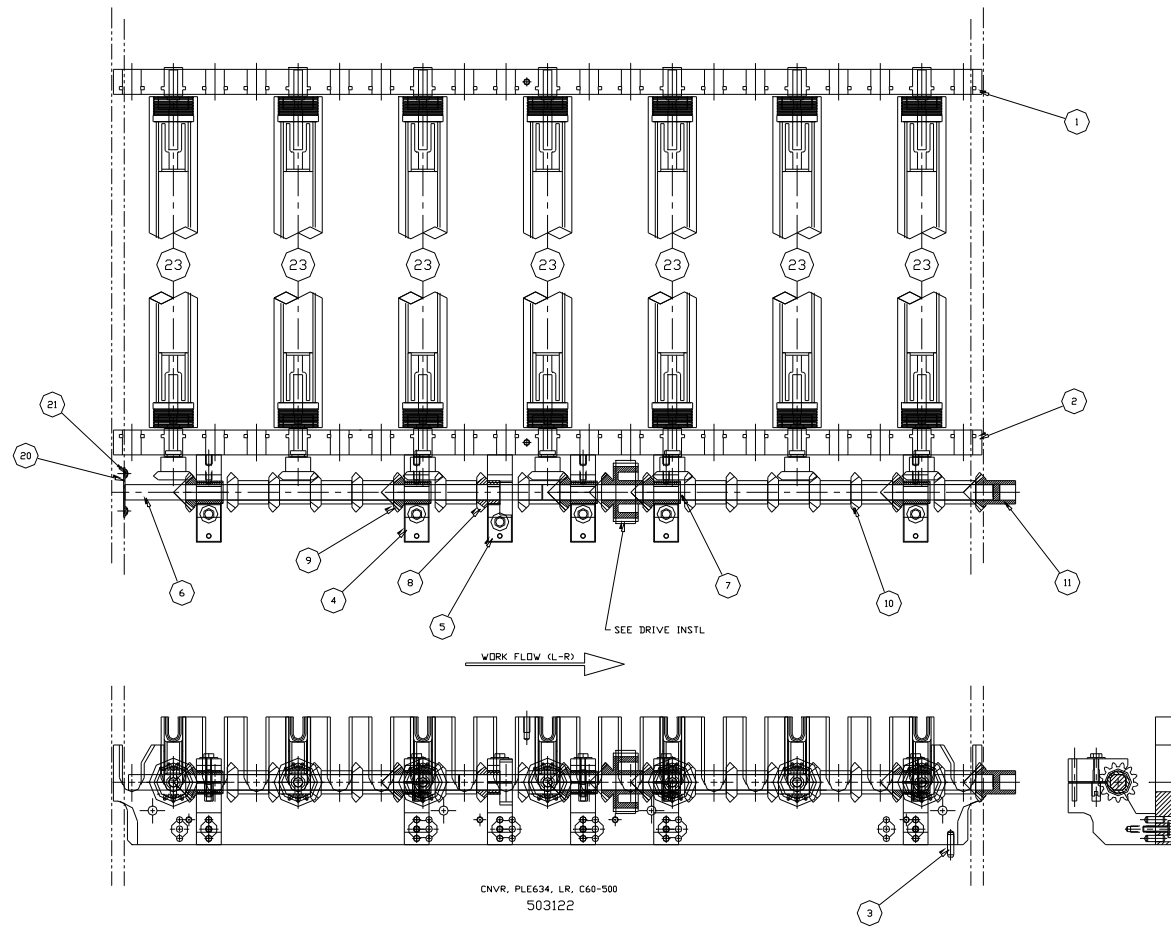

**503122 CNVR,ROLL,PLE634,LR,C60-500**

ITEM_#_ON	DRAWING	PART_NUMBER	DESCRIPTION	QUANTITY
1		501492	SIDERAIL,REAR,21 ROD,PIA34	1.
2		501493	SIDERAIL,FRONT,21 ROD,PIA34	1.
3		023353	PIN,GRAPHITE,1/4ODX1LG	2.
4		500932	STRUT,P-SIGMA,STD,TI *	5.
5		500933	STRUT,P-SIGMA,L-R,TI	1.
6		502994	SHAFT,LINE,TI,16-11/16	1.
7		502995	SHAFT,LINE,TI,18	1.
8		501024	GEAR,MITER,13T,PVDF,.929,9P *	1.
9		501025	GEAR,MITER,13T,PVDF,1.500,9P *	5.
10		501026	GEAR,MITER,13T,PVDF,1.662,9P	12.
11		501060	GEAR,MITER,13T,PVDF,1.474,9P *	1.
20		501065	PLATE,SKID,DRIVELINE *	1.
21		003615	SCREW,PAN,SST18-8,10-32 X 1/4"	2.
23		503130	ROLL,60,2X2,SOLID,LWR,TPN/TI	7.

9.1.3 ROLL,60,2X2,SOLID,LWR,TPN/T

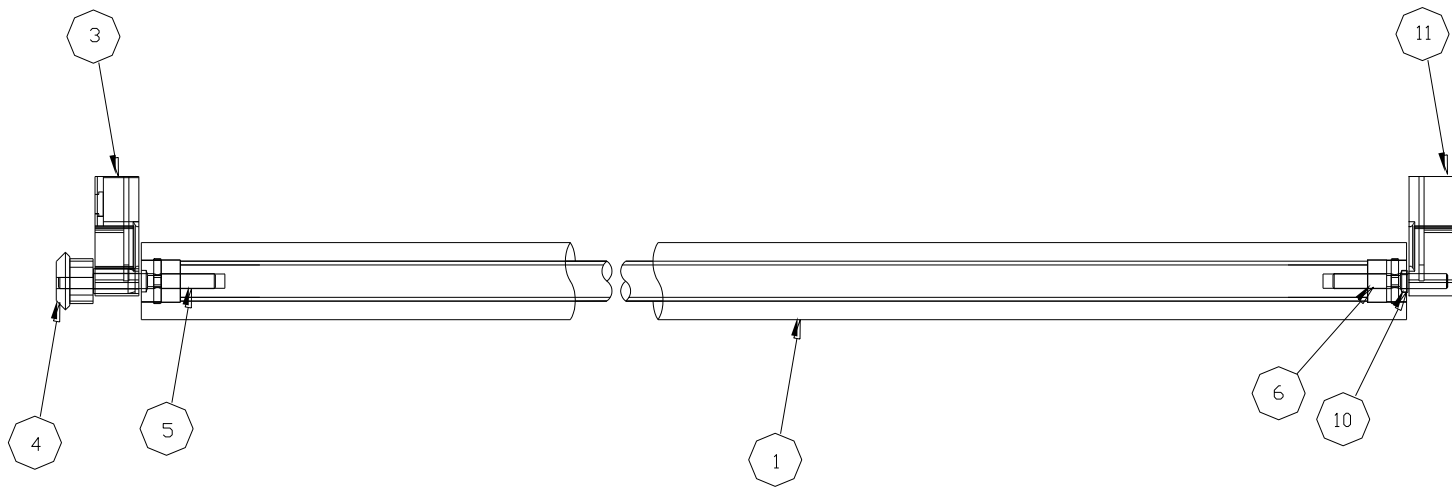

ROLL, 60, 2X2, SOLID, LWR  
503130

**503130      ROLL,60,2X2,SOLID,LWR,TPN/T**

|

ITEM\_#\_ON

DRAWING	PART_NUMBER	DESCRIPTION	QUANTITY
1	501536	ROLL,D,61-3/4X1.9,TPN	1.
3	501015	INSERT,SRAIL,SLTD1-15/16,PVDF*	1.
4	501019	GEAR,MITER,SPUR,13T,PVDF .920*	1.
5	149401	SHAFT,PIN,TI,3/8X3-15/16LG *	1.
6	149399	SHAFT,PIN,TI,3/8X2-7/8LG *	1.
10	141546	CLIP,RETAINER,PPL	1.
11	501016	INSERT,SRAIL,BLIND1-15/16PVDF*	1.

### 9.1.4 DRIVE, PLE634, 140IPM, TI, C60-500

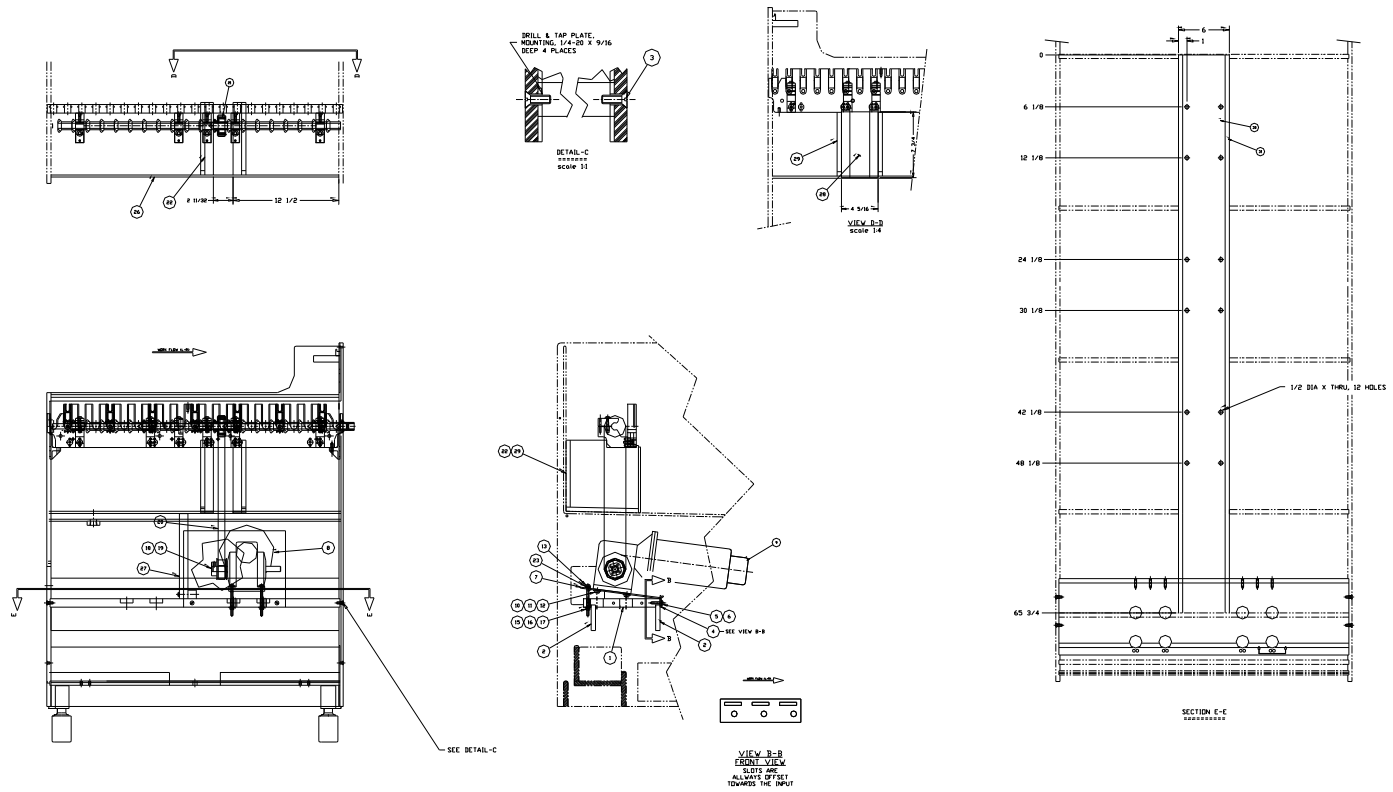

DRIVE, PLE634, C60-500  
503078

**503078 DRIVE,PLE634,140IPM,TI,C60-500**

ITEM_#_ON	DRAWING	PART_NUMBER	DESCRIPTION	QUANTITY
1		502383	MOUNT,MOTOR,DRIVE,PIA*34	1.
2		067264	PVC,1/2 X 3	34.000
2		067264	PVC,1/2 X 3	34.000
3		035566	SCREW,FLAT,SST316,1/4-20X1	4.0
4		502361	PLATE,MTG,TENSION ADJ,P-S,TI	1.
5		003019	BOLT,HEX,TI,5/16-18X3/4	3.
6		003055	WASHER,FLAT,TI,5/16"NOM	3.
7		502362	PLATE,TENSION ADJUST,P-SIG,TI	1.
8		114593	REDUCER,SPEED,60:1	1.0
9		105659	MOTOR,DC,1/4 HP,TACH-7V/K,CE *	1.0
10		003019	BOLT,HEX,TI,5/16-18X3/4	4.
11		003055	WASHER,FLAT,TI,5/16"NOM	4.
12		013155	WASHER,LOCK,SST316,5/16"NOM	4.0
13		100128	BOLT,HEX,TI,1/4-20X3	2.
15		003056	WASHER,FLAT,TI,1/4 NOM	2.
16		026866	WASHER,LOCK,SST316,1/4"NOM	2.0
17		003032	NUT,HEX,TI,1/4-20	2.
18		087396	SPROCKET,BELT,HTD,BLK,5/8ID,24	1.0
19		170135	KEY,SQ TI,3/16X3/4LG	1.
20		080853	BELT,HTD,1040-8M-20	1.0
21		501087	GEAR,DRIVE,PVDF,9P,1.662,24T	1.0
22		501085	SUPPORT,DRIVE,SIDERAIL,P-SIGMA	2.0
23		501229	WASHER,DOMED,SST303,5/16-NOM	2.
26		503082	PAN,PLE634,OUTPUT DRIVE	1.
27		501230	COVER/BASE PAN SUPPORT,P-SIGMA	1.0
28		137354	SHEET,PVC,EUROGRY,1/4X48X100IN	24.0
29		069565	PVC,1/2 X 1/2	24.0
30		067246	PVC,1/2 X 6	65.750
31		069686	PVC,1/2 X 1	65.750
31		069686	PVC,1/2 X 1	65.750



## 9.2 PIA634 Conveyor

### 9.2.1 PIA634M PIA634,MEC PARTS,P-SIGMA

ITEM_#_ON	DRAWING	PART_NUMBER	DESCRIPTION	QUANTITY
0	503183	CHAMBER,PIA634		1.
3	750034	COVER,SIDERAIL,REAR,PIA334		1.
4	750035	COVER,SIDERAIL,FRONT,PIA334		1.
5	503159	PLENUM,PRE634		1.
5	503188	PLENUM,PLE634		1.
6	131644	COVER INSTL,FRONT,33.882		1.
7	503158	MOD.INT.PARTS,P-SIGMA,60,TI		1.
	136186	LABELS,SIGMA,TIA,STD		1
	503127	CNVR,ROLL,PIA634,LR,C60-500		1
	503181	DRIVE,PIA634,NO-DRIVE,PAN ONLY		1
	503194	VENT INSTL,P-SIGMA,60"		1

## 9.2.2 CNVR,ROLL,PIA634,LR,C60-500

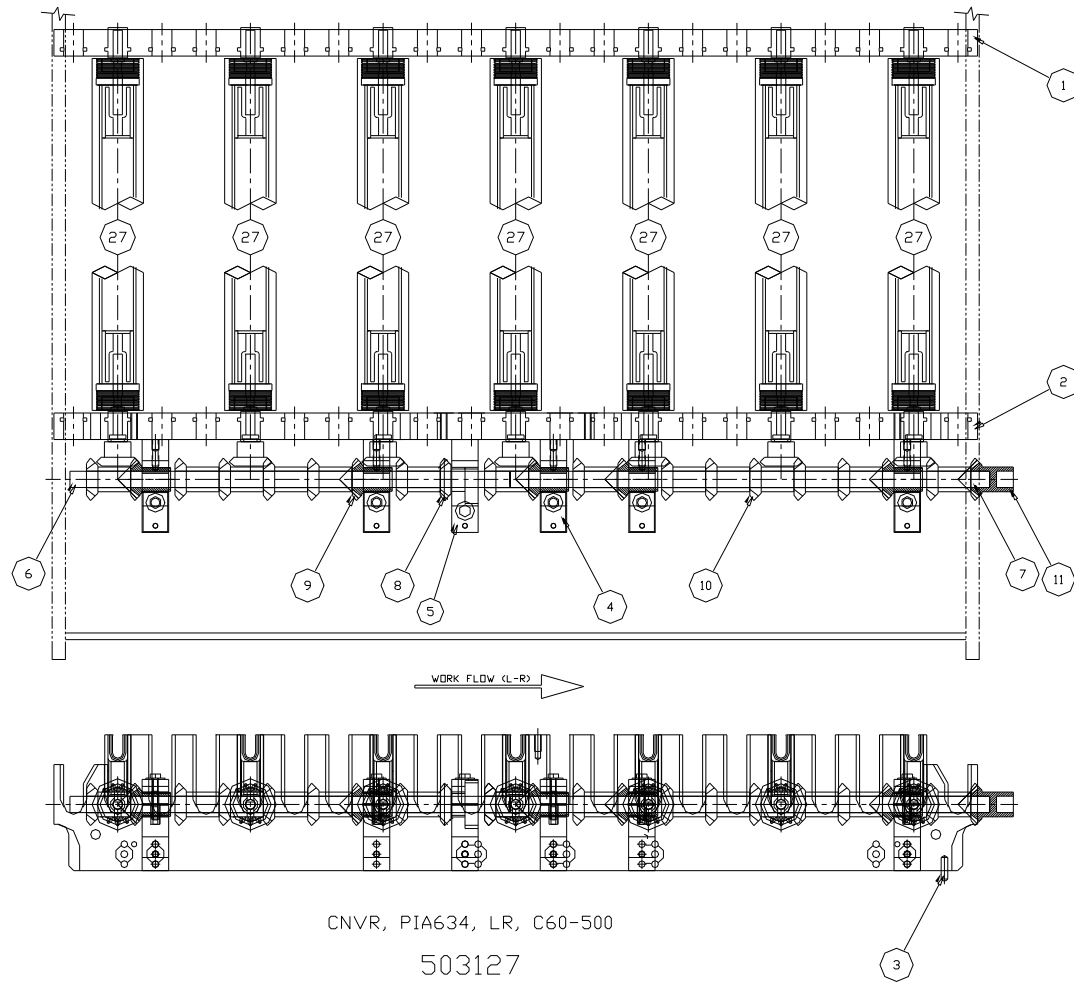

**503127 CNVR,ROLL,PIA634,LR,C60-500**

ITEM_#_ON	DRAWING	PART_NUMBER	DESCRIPTION	QUANTITY
1		501492	SIDERAIL,REAR,21 ROD,PIA34	1.
2		501493	SIDERAIL,FRONT,21 ROD,PIA34	1.
3		023353	PIN,GRAPHITE,1/4ODX1LG	2.
4		500932	STRUT,P-SIGMA,STD,TI *	5.
5		500933	STRUT,P-SIGMA,L-R,TI	1.
6		501508	SHAFT,LINE,TI,16-9/16	1.
7		502995	SHAFT,LINE,TI,18	1.
8		501024	GEAR,MITER,13T,PVDF,.929,9P *	1.
9		501025	GEAR,MITER,13T,PVDF,1.500,9P *	5.
10		501026	GEAR,MITER,13T,PVDF,1.662,9P	14.
11		501027	GEAR,MITER,13T,BLIND,PVDF,9P *	1.
27		503130	ROLL,60,2X2,SOLID,LWR,TPN/TI	7.

9.2.3 ROLL,60,2X2,SOLID,LWR,TPN/T

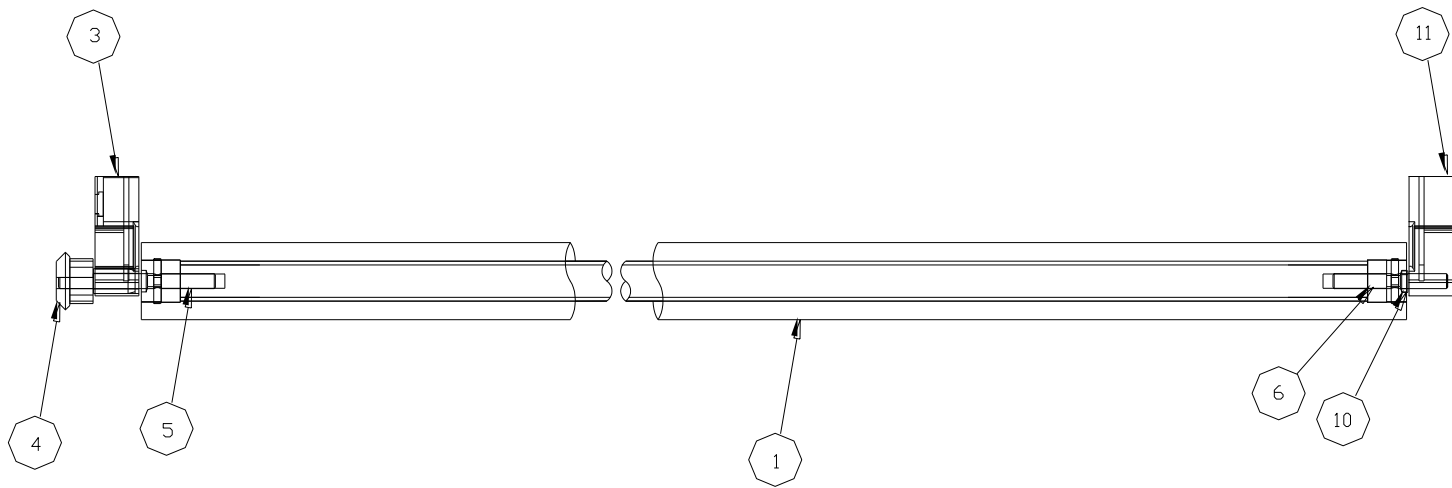

ROLL, 60, 2X2, SOLID, LWR  
503130

**503130      ROLL,60,2X2,SOLID,LWR,TPN/T**

|

ITEM\_#\_ON

DRAWING	PART_NUMBER	DESCRIPTION	QUANTITY
1	501536	ROLL,D,61-3/4X1.9,TPN	1.
3	501015	INSERT,SRAIL,SLTD1-15/16,PVDF*	1.
4	501019	GEAR,MITER,SPUR,13T,PVDF .920*	1.
5	149401	SHAFT,PIN,TI,3/8X3-15/16LG *	1.
6	149399	SHAFT,PIN,TI,3/8X2-7/8LG *	1.
10	141546	CLIP,RETAINER,PPL	1.
11	501016	INSERT,SRAIL,BLIND1-15/16PVDF*	1.

## 9.2.4 VENT INSTL,P-SIGMA,60"

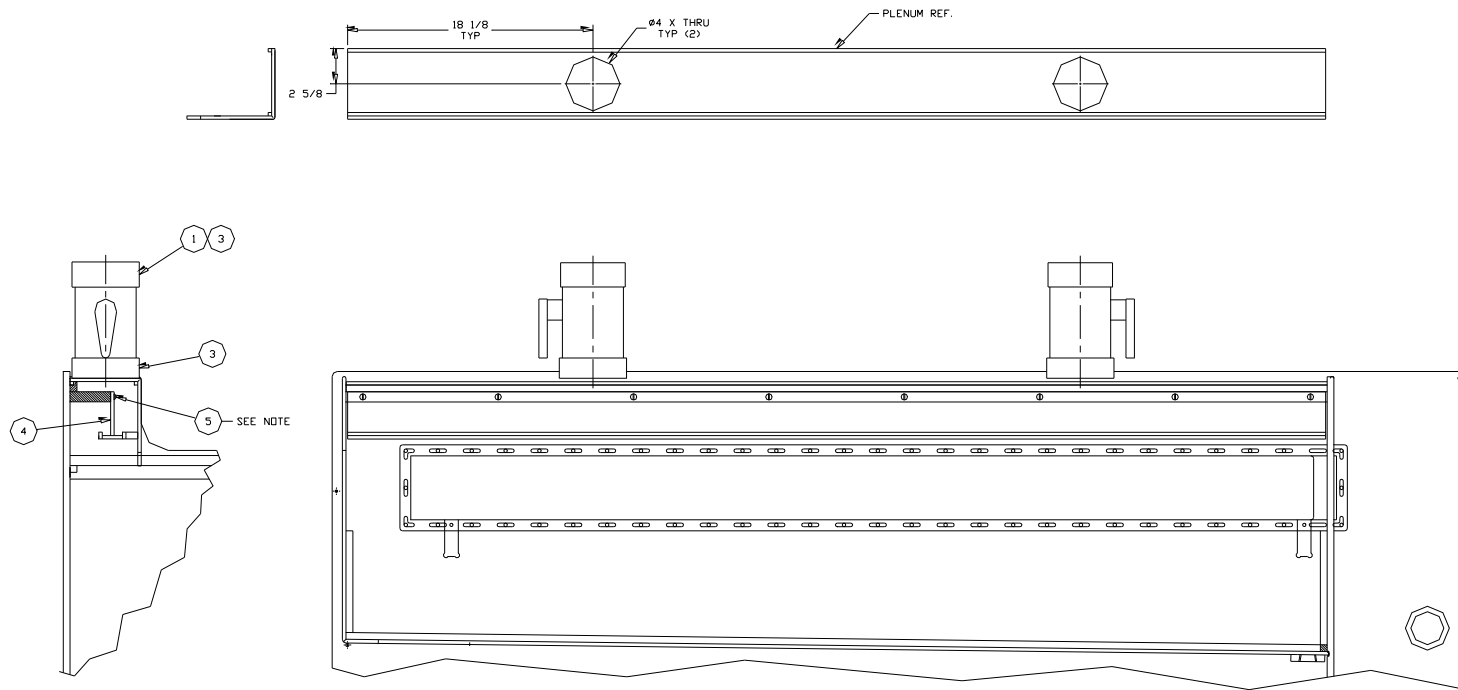

NOTE: DRILL AND TAP 1/4-20 X 13/4 DP. USING ITEM #4 AS TEMPLATE.  
TYP (6 HOLES)

VENT INSTL., P-SIG, 60"  
503194

**503194      VENT INSTL,P-SIGMA,60"**

ITEM\_#\_ON

DRAWING	PART_NUMBER	DESCRIPTION	QUANTITY
0	503159	PLENUM,PRE634	0.00000
0	503188	PLENUM,PLE634	0.00000
1	023936	COLLAR,VENT,PVC,MOLDED,4"	2.
2	011607	DAMPER ASSY,PVC,4"ID	2.
3	049817	ADAPTER,VENT,PVC,MOLDED,4"	2.
4	503195	BAFFLE ASSY,PLENUM,60,P-SIG	1.
5	002711	SCREW,RD,TI,1/4-20 X 3/4"	8.

## 9.3 POS607 Ferric Chloride Etch

### 9.3.1 POS607M-1 POS607,MEC PARTS,NO/AIR SEAL

ITEM_#_ON	DRAWING	PART_NUMBER	DESCRIPTION	QUANTITY
	0	503094	POS607 MOD ASSY,NO/AIR SEAL	1.
	0	503095	MODULE INT,POS607,TI,N/AIRSEAL	1.

### 9.3.2 POS607 MOD ASSY,NO/AIR SEAL

#### 503094 POS607 MOD ASSY,NO/AIR SEAL

ITEM_#_ON	DRAWING	PART_NUMBER	DESCRIPTION	QUANTITY
	0	503056	CHAMBER,POS607,NO/AIR SEAL	1.
	0	503105	PLUMBING,POS607	1.
	3	503106	SPRAYRACK INSTL,POS607,(40-PG)	1.
	0	503097	DRIVE INSTL,OSCILLATION,POS607	2.
	0	503099	COOLING,POS607	2.
	0	503107	JCT BOX INSTL,AIRGAP,POS607	1.
	0	131577	COVER INSTL,FRONT,TOS*06	1.
	0	144090	COVER INSTL,OSC,OS	2.
	0	501748	COVER,SUMP ACCESS/SAMPLE,POS	1.
	0	501749	COVER,SUMP ACCESS,POS	2.
	0	600404	PLUG,PORT,PVC,XLI	1.
	0	170088	GAUGE INSTL,PRESS,PEM,(2)	2.
		136179	LABELS,SIGMA,TOS,STD	1
		502809	BAG,FILTER,80MIC,PLYESTR,(2)	1



502817	RECIRC PUMP,(2)POS,3HP,W/FEEDS	1
503113	GAUGE INSTL,POS607,0-60 (40)	1
503126	HEAT,6X6KW,440-480V,TI,M BLD	1
503129	CNVR,ROLL,POS607,LR,N/OUT ROLL	1
503135	PUMP,2X7.5,P-55CJ-CI,TI IMPELL	1
503136	NOZZLE,1.5GPM,073711,SCRD(140)	1
503137	INTERCONNECT,SUMP,POS (4-EA)	1
503156	SUPPLY,PVC SOL,1/2",POS	1
503223	NOZZLE INSTL,EDGE ETCH	1

### 9.3.3 MODULE INT,POS607,TI,N/AIRSEAL

#### 503095 MODULE INT,POS607,TI,N/AIRSEAL

ITEM_#_ON	DRAWING	PART_NUMBER	DESCRIPTION	QUANTITY
0	503108	DOOR INSTL,FRONT,POS*07,N/AIRS		1.
0	503192	DOOR INSTL,REAR,POS*07,N/AIRS		1.
0	503109	LID INSTL,TOP POS607,N/AIRSEAL		1.
0	503096	GASKET,CNVR,P-SIGMA,60,TPE55A		1.
0	503104	ANGLE,OPENING,P-SIGMA,60,TI		4.
0	141115	BOLT,HEX,TI,1/4-20X1-1/4		58.
0	003032	NUT,HEX,TI,1/4-20		58.
0	142534	PIN,GRAPHITE,1/4ODX3/4LG		2.
0	143787	LABEL,UPPER,INPUT		1.
0	143788	LABEL,UPPER,OUTPUT		1.
0	143789	LABEL,LOWER,INPUT		1.
0	143790	LABEL,LOWER,OUTPUT		1.
0	049817	ADAPTER,VENT,PVC,MOLDED,4"		2.
0	501035	PLATE,CONN,FRONT,P-SIGM,TI		2.
0	501036	PLATE,CONN,REAR,P-SIGMA,TI		2.

9.3.4 DRIVE INSTL,OSCILLATION,POS607

503097 No Drawing

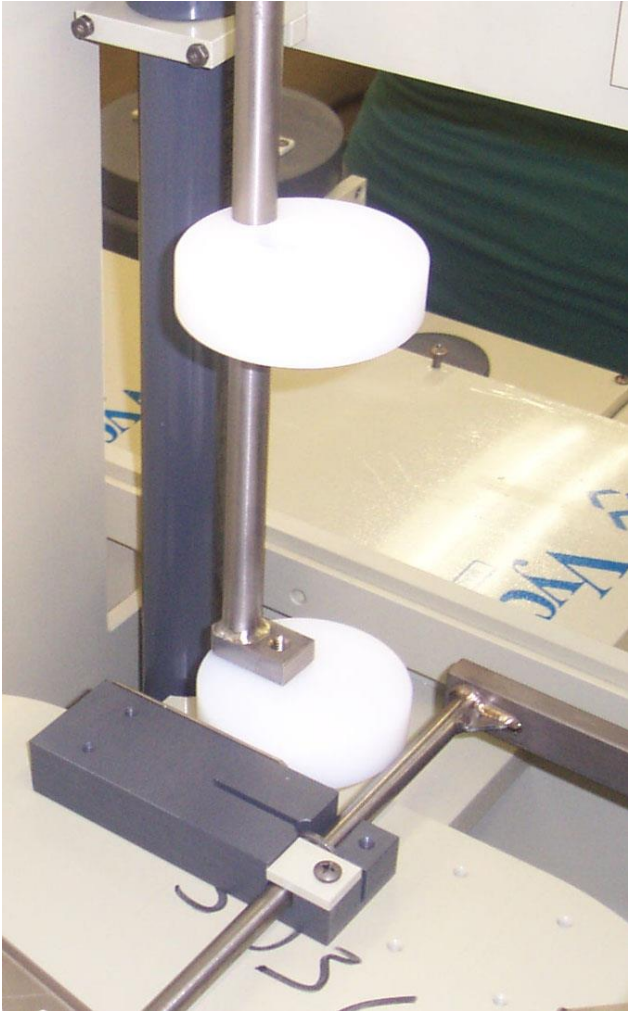

**503097 DRIVE INSTL,OSCILLATION,POS607**

ITEM_#_ON	DRAWING	PART_NUMBER	DESCRIPTION	QUANTITY
1		144240	MOTOR,GEAR,DC,1/4HP,68RPM,RITE	1.
2		144630	CLAMP ASSY,MOTOR,OSC,PVC,TOS	1.
3		003024	BOLT,HEX,TI,1/4-20X1	4.
4		003056	WASHER,FLAT,TI,1/4 NOM	4.
5		501596	BUSHING,UPPER,OSC,POS	1.
6		069565	PVC,1/2 X 1/2	12.000
7		501718	BEARING,LOWER,OSC,UHMW	1.
8		031243	PIN,TI,.125ODX1LG	2.
9		144243	COUPLING,DRIVE,OSC,OS	1.
10		148916	KEY,SQ TI,3/16X1-1/2LG	1.
11		029163	SETSCREW,TI,1/4-20X1/4",CUP PT	2.
12		503085	PLATE,SEAL,OSCILLATION,POS,MOD	1.
12		503092	BRACKET,SHAFT,OSC,LWR,POS607	0.00000
13		159857	SEAL,O-RING,2-241,EPDM,BLACK	2.
14		002711	SCREW,RD,TI,1/4-20 X 3/4"	4.
15		082298	SEAL,V-RING,CVU-1220,PTFE	1.
16		148952	CAP,BEARING,PVC	1.
17		502731	SHAFT ASSY,OSC,POS	1.
18		501080	CAM,OSCILLATION,POS	2.
19		003008	BOLT,HEX,TI,3/8-16X1-1/2	2.
20		003012	NUT,HEX,TI,3/8-16	2.

### 9.3.5 SPRAYRACK INSTL,POS607,(40-PG)

Lower Racks Shown



**503106      SPRAYRACK INSTL,POS607,(40-PG)**

ITEM_#_ON	DRAWING	PART_NUMBER	DESCRIPTION	QUANTITY
0		503114	SPRAYRACK ASSY,UP/LEFT,POS607	1.
0		503141	SPRAYRACK ASSY,LOW/LEFT,POS607	1.
0		503151	SPRAYRACK ASSY,UP/RIGHT,POS607	1.
0		503169	SPRAYRACK ASSY,LOW/RHGT,POS607	1.
5		503120	PIN,RACK SUPPORT ROLLER	8.
6		503119	ROLLER,RACK SUPPORT	16.
7		130994	WASHER,HDPE,.380IDX1ODX1/16THK	16.
8		503121	COLLAR,LOCK,RACK ROLLER	8.

**9.3.6 SPRAYRACK ASSY,UP/LEFT,POS607**



**503114      SPRAYRACK ASSY,UP/LEFT,POS607**

ITEM_#_ON	DRAWING	PART_NUMBER	DESCRIPTION	QUANTITY
1		503115	PLATE, TOP, UPPER RACK, LFT, 40 NZ	1.
2		503116	PLATE, BOT, UPPER RACK, LFT, 40 NZ	1.
0		700404	SEAL, O-RING, EPDM, 1/8 X RANDOM	50.000
9		501073	ROLLER GUIDE, SPRAY RACK	8.
10		502552	PIN, ROLLER, SPRAYRACK	8.
11		002710	SCREW, RD, TI, 1/4-20 X 1"	10.
12		503128	BLOCK, ROLLER MTG, OFFSET, POS607	4.
13		003029	SCREW, RD, TI, 1/4-20 X 1-1/4"	10.
17		503132	BRACE, SPRAYRACK, UPR LFT, 65.25"	1.
19		503134	BRACE, SPRAYRACK, TI, 65.250"	1.
23		503138	BRACE, SPRAYRACK, TI, 14.250"	20.
25		009356	BOLT, HEX, TI, 1/4-20X1-3/4	115.
26		003032	NUT, HEX, TI, 1/4-20	115.
28		501098	ADAPTER, ADJUST PLUG, 1-14 UNF	10.
31		501097	PLUG, ADJUSTING, PPL, 1-14 UNF	10.
37		145556	SCREW, FLAT, TI, 10-24 X 3/4"	2.
39		503139	CAM LOCK INSTL, POS60*	1.
41		142534	PIN, GRAPHITE, 1/4ODX3/4LG	2.
42		003056	WASHER, FLAT, TI, 1/4 NOM	6.



**9.3.7 SPRAYRACK ASSY,LOW/LEFT,POS607**

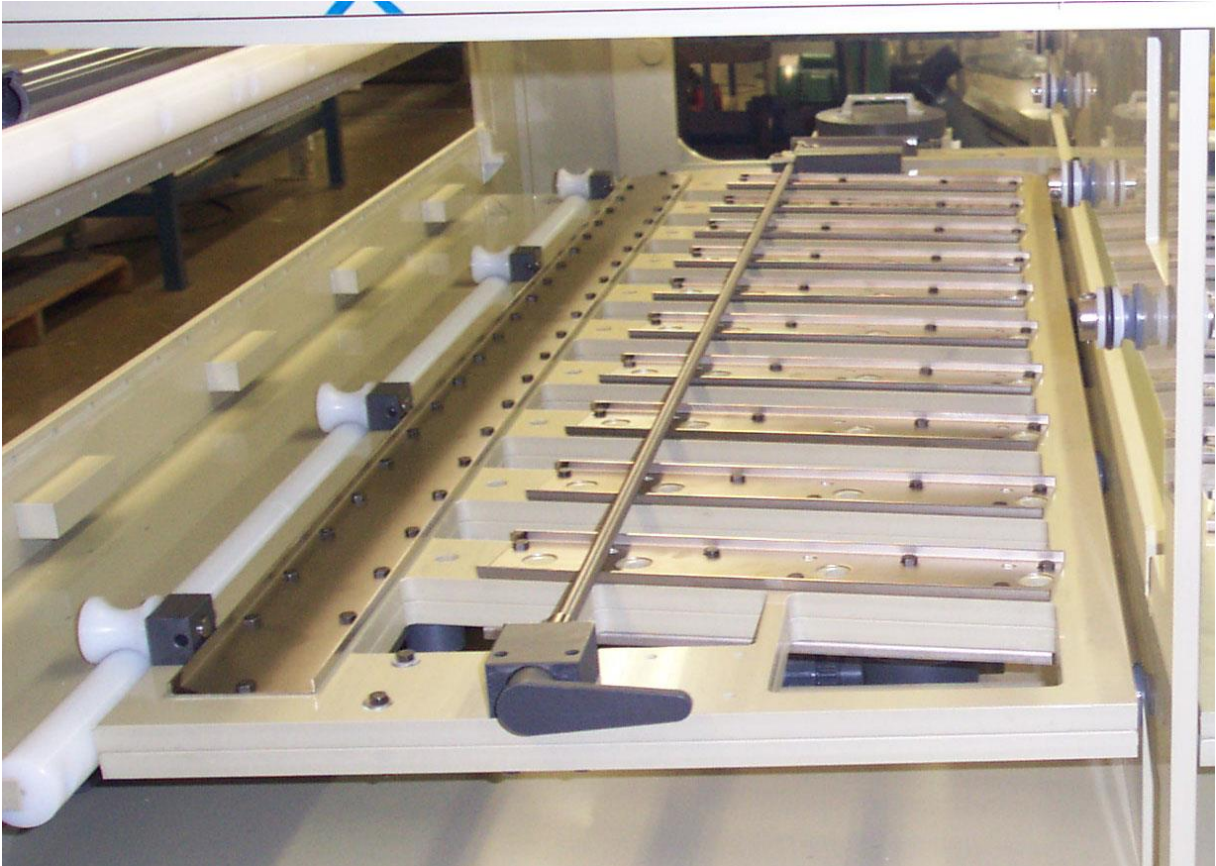



**503141      SPRAYRACK ASSY,LOW/LEFT,POS607**

ITEM_#_ON	DRAWING	PART_NUMBER	DESCRIPTION	QUANTITY
1		503142	PLATE,TOP,LOWER RACK,LFT,40 NZ	1.
2		503143	PLATE,BOT,LOWER RACK,LFT,40 NZ	1.
0		700404	SEAL,O-RING,EPDM,1/8 X RANDOM	50.000
9		501073	ROLLER GUIDE,SPRAY RACK	8.
10		502552	PIN,ROLLER,SPRAYRACK	8.
11		002710	SCREW,RD,TI,1/4-20 X 1"	10.
12		503150	BLOCK,ROLLER MTG,SPRAYRACK,LWR	4.
13		003029	SCREW,RD,TI,1/4-20 X 1-1/4"	10.
17		503149	BRACE,SPRAYRACK,LWR LFT,65.25"	1.
19		503134	BRACE,SPRAYRACK,TI,65.250"	1.
23		503138	BRACE,SPRAYRACK,TI,14.250"	20.
25		009356	BOLT,HEX,TI,1/4-20X1-3/4	115.
26		003032	NUT,HEX,TI,1/4-20	115.
28		501098	ADAPTER,ADJUST PLUG,1-14 UNF	10.
31		501097	PLUG,ADJUSTING,PPL,1-14 UNF	10.
37		145556	SCREW,FLAT,TI,10-24 X 3/4"	2.
39		503139	CAM LOCK INSTL,POS60*	1.
41		142534	PIN,GRAPHITE,1/4ODX3/4LG	2.
42		003056	WASHER,FLAT,TI,1/4 NOM	6.

**9.3.8 SPRAYRACK ASSY,UP/RIGHT,POS607**



**503151      SPRAYRACK ASSY,UP/RIGHT,POS607**

ITEM_#_ON	DRAWING	PART_NUMBER	DESCRIPTION	QUANTITY
1		503152	PLATE, TOP, UPPER RACK, RHT, 30 NZ	1.
2		503153	PLATE, BOT, UPPER RACK, RHT, 30 NZ	1.
0		700404	SEAL, O-RING, EPDM, 1/8 X RANDOM	50.000
9		501073	ROLLER GUIDE, SPRAY RACK	8.
10		502552	PIN, ROLLER, SPRAYRACK	8.
11		002710	SCREW, RD, TI, 1/4-20 X 1"	10.
12		503128	BLOCK, ROLLER MTG, OFFSET, POS607	4.
13		003029	SCREW, RD, TI, 1/4-20 X 1-1/4"	10.
17		503167	BRACE, SPRAYRACK, UPR RHT, 65.25"	1.
19		503134	BRACE, SPRAYRACK, TI, 65.250"	1.
23		503168	BRACE, SPRAYRACK, TI, 11.875"	20.
25		009356	BOLT, HEX, TI, 1/4-20X1-3/4	104.
26		003032	NUT, HEX, TI, 1/4-20	104.
28		501098	ADAPTER, ADJUST PLUG, 1-14 UNF	10.
31		501097	PLUG, ADJUSTING, PPL, 1-14 UNF	10.
37		145556	SCREW, FLAT, TI, 10-24 X 3/4"	2.
39		503139	CAM LOCK INSTL, POS60*	1.
41		142534	PIN, GRAPHITE, 1/4ODX3/4LG	2.
42		003056	WASHER, FLAT, TI, 1/4 NOM	6.

9.3.9 SPRAYRACK ASSY,LOW/RHGT,POS607



**503169      SPRAYRACK ASSY,LOW/RHGT,POS607**

ITEM_#_ON	DRAWING	PART_NUMBER	DESCRIPTION	QUANTITY
1		503170	PLATE,TOP,LOWER RACK,RHT,30 NZ	1.
2		503171	PLATE,BOT,LOWER RACK,RHT,30 NZ	1.
0		700404	SEAL,O-RING,EPDM,1/8 X RANDOM	50.000
9		501073	ROLLER GUIDE,SPRAY RACK	8.
10		502552	PIN,ROLLER,SPRAYRACK	8.
11		002710	SCREW,RD,TI,1/4-20 X 1"	10.
12		503150	BLOCK,ROLLER MTG,SPRAYRACK,LWR	4.
13		003029	SCREW,RD,TI,1/4-20 X 1-1/4"	10.
17		503172	BRACE,SPRAYRACK,LWR RHT,65.25"	1.
19		503134	BRACE,SPRAYRACK,TI,65.250"	1.
23		503168	BRACE,SPRAYRACK,TI,11.875"	20.
25		009356	BOLT,HEX,TI,1/4-20X1-3/4	104.
26		003032	NUT,HEX,TI,1/4-20	104.
28		501098	ADAPTER,ADJUST PLUG,1-14 UNF	10.
31		501097	PLUG,ADJUSTING,PPL,1-14 UNF	10.
37		145556	SCREW,FLAT,TI,10-24 X 3/4"	2.
39		503139	CAM LOCK INSTL,POS60*	1.
41		142534	PIN,GRAPHITE,1/4ODX3/4LG	2.
42		003056	WASHER,FLAT,TI,1/4 NOM	6.

### 9.3.10 CNVR,ROLL,POS607,LR,N/OUT ROLL

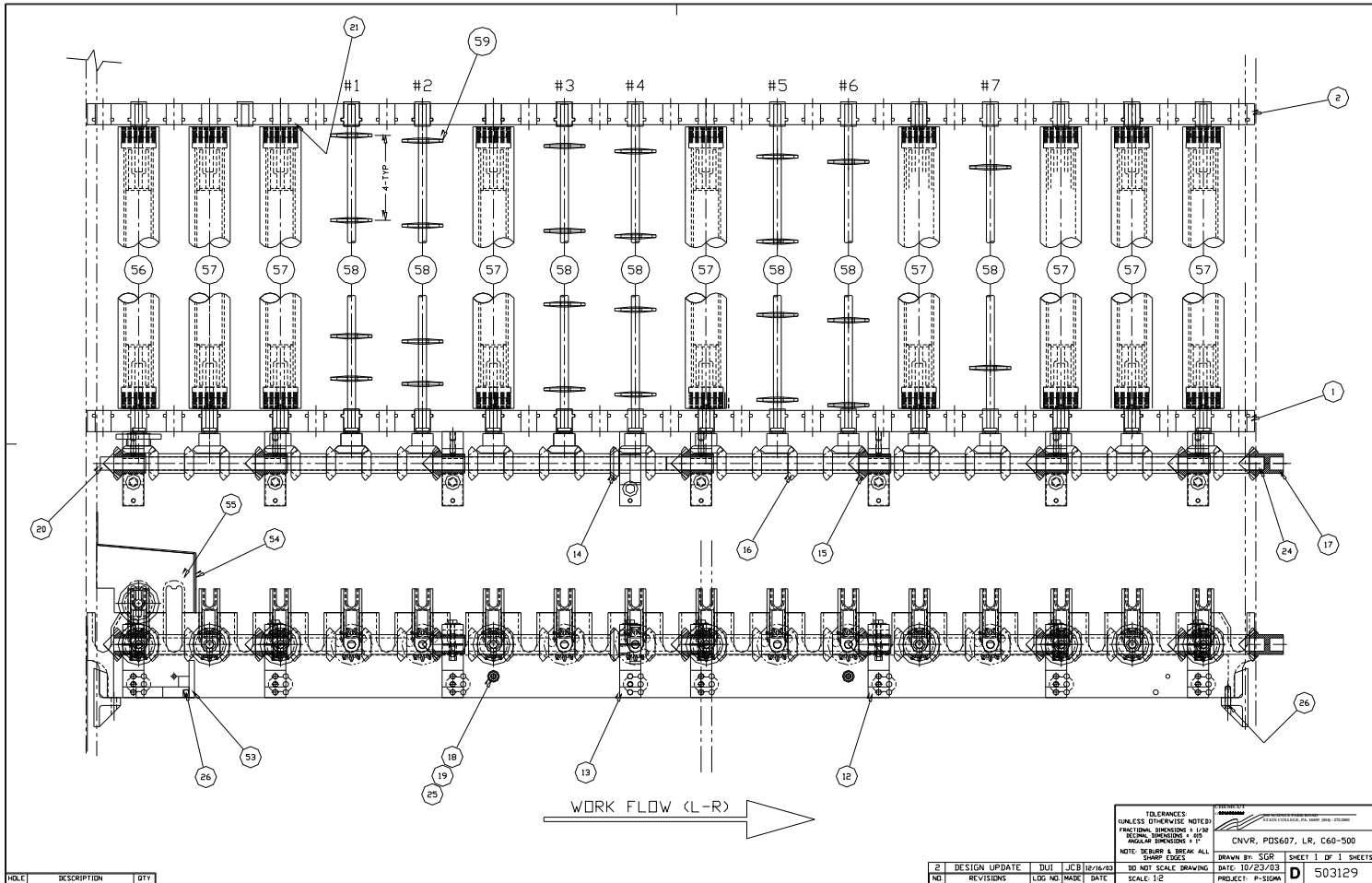

**503129 CNVR,ROLL,POS607,LR,N/OUT ROLL**

ITEM_#_ON	DRAWING	PART_NUMBER	DESCRIPTION	QUANTITY
1		500995	SIDERAIL,FRONT,33 ROD,POS07	1.
2		500996	SIDERAIL,REAR,33 ROD,POS07	1.
12		500932	STRUT,P-SIGMA,STD,TI *	7.
13		500933	STRUT,P-SIGMA,L-R,TI	1.
14		501024	GEAR,MITER,13T,PVDF,.929,9P *	1.
15		501025	GEAR,MITER,13T,PVDF,1.500,9P *	7.
16		501026	GEAR,MITER,13T,PVDF,1.662,9P	24.
17		501027	GEAR,MITER,13T,BLIND,PVDF,9P *	1.
18		503259	ROD,TIE,CNVR,TI,60	2.
19		003032	NUT,HEX,TI,1/4-20	8.
20		501358	SHAFT,LINE,TI,26.576	1.
21		501107	BRACE,SIDERAIL,POS07	2.
24		501359	SHAFT,LINE,TI,28.057	1.
25		003056	WASHER,FLAT,TI,1/4 NOM	4.
26		023353	PIN,GRAPHITE,1/4ODX1LG	4.
53		604176	BAFFLE,LWR,60,1-ROLL,PVC,EXT	1.
54		604177	BAFFLE,UPPER,TI,60,POS607	1.
55		502467	END PLATE,BAFFLE,POS	2.
56		503123	ROLL,60,2X2,SOLID,TPN/TI*	1.
57		503130	ROLL,60,2X2,SOLID,LWR,TPN/TI	8.
58		503281	ROD,60,2X2,LWR ONLY,GRAPHITE	7.
59		106950	WHEEL,CNVR,TPN45D,2SX3/8,5HOLE	108.

9.3.11 ROLL,60,2X2,SOLID,TPN/TI\*

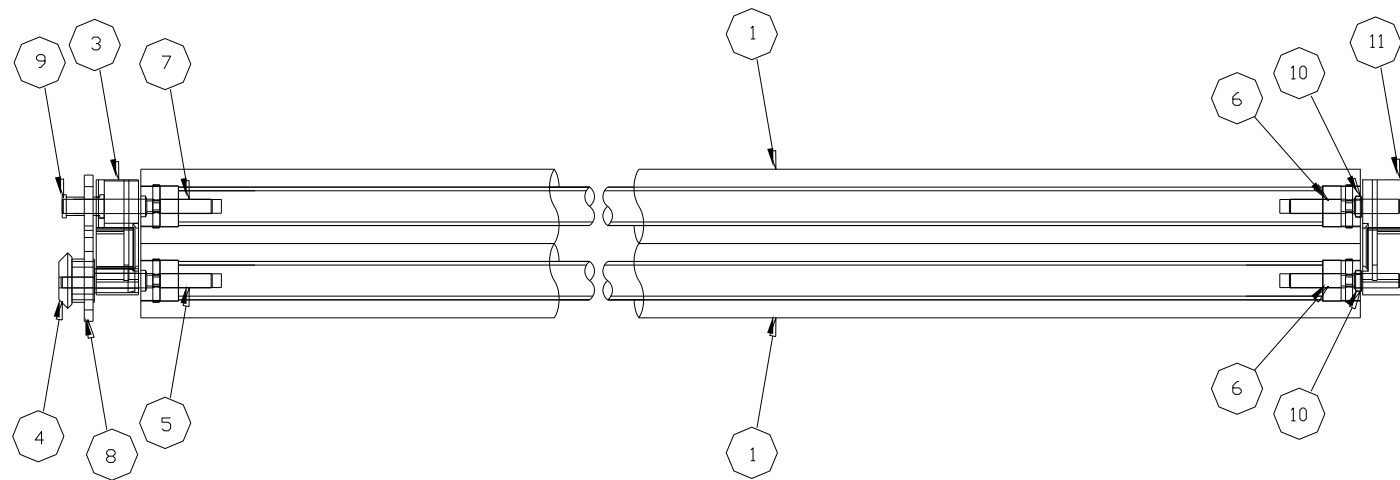

ROLL, 60, 2X2, SOLID, TPN/TI  
503123



**503123      ROLL,60,2X2,SOLID,TPN/TI\***

ITEM_#_ON	DRAWING	PART_NUMBER	DESCRIPTION	QUANTITY
1	501536	ROLL,D,61-3/4X1.9,TPN		2.
3	501015	INSERT,SRAIL,SLTD1-15/16,PVDF*		1.
4	501019	GEAR,MITER,SPUR,13T,PVDF .920*		1.
5	149401	SHAFT,PIN,TI,3/8X3-15/16LG *		1.
6	149399	SHAFT,PIN,TI,3/8X2-7/8LG *		2.
7	137116	SHAFT ASSY,1PIN/SK,TI *		1.
8	501020	GEAR,SPUR,15T,EXT,PVDF *		1.
9	501041	GEAR,SPUR,15T,TABBED,PVDF *		1.
10	141546	CLIP,RETAINER,PPL		2.
11	501016	INSERT,SRAIL,BLIND1-15/16PVDF*		1.

9.3.12 ROLL,60,2X2,SOLID,LWR,TPN/T

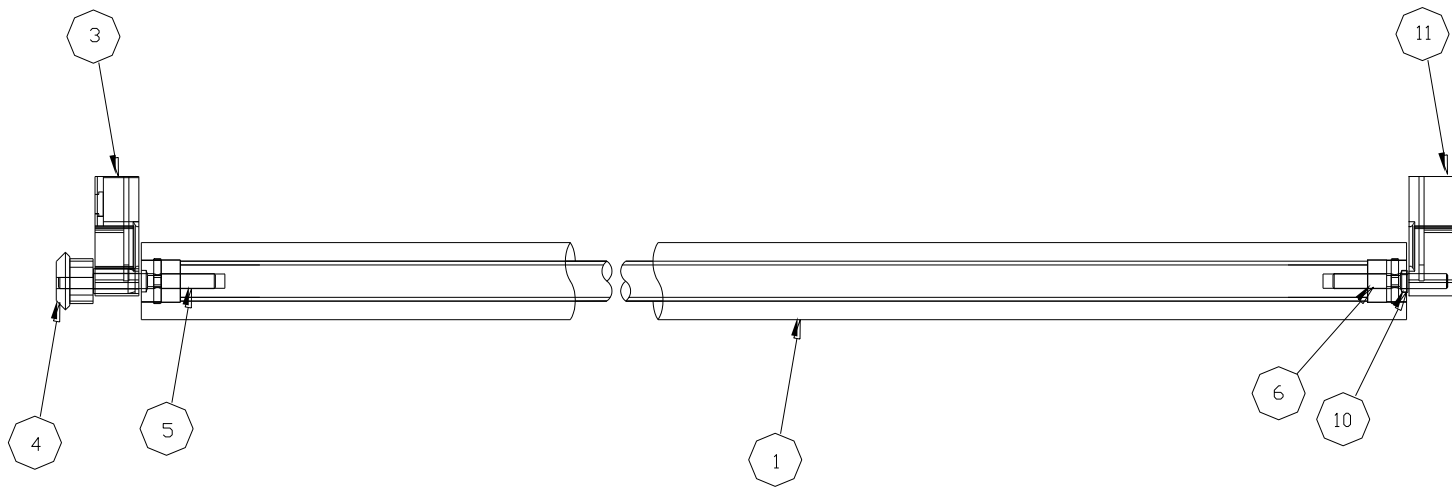

ROLL, 60, 2X2, SOLID, LWR  
503130

**503130      ROLL,60,2X2,SOLID,LWR,TPN/T**

|

ITEM\_#\_ON

DRAWING	PART_NUMBER	DESCRIPTION	QUANTITY
1	501536	ROLL,D,61-3/4X1.9,TPN	1.
3	501015	INSERT,SRAIL,SLTD1-15/16,PVDF*	1.
4	501019	GEAR,MITER,SPUR,13T,PVDF .920*	1.
5	149401	SHAFT,PIN,TI,3/8X3-15/16LG *	1.
6	149399	SHAFT,PIN,TI,3/8X2-7/8LG *	1.
10	141546	CLIP,RETAINER,PPL	1.
11	501016	INSERT,SRAIL,BLIND1-15/16PVDF*	1.

**9.3.13 ROD,60,2X2,LWR ONLY,GRAPHITE**



ROD 2X2,LWR ONLY 30 GFK  
501007

**503281      ROD,60,2X2,LWR ONLY,GRAPHITE**

ITEM_#_ON	DRAWING	PART_NUMBER	DESCRIPTION	QUANTITY
0	501007	ROD,30,2X2,LWR ONLY,FBRGL	*	0.00000000
1	503282	ROD,GRAPHITE,3/8X65,D	*	1.
2	501015	INSERT,SRAIL,SLTD1-15/16,PVDF*		1.
3	501016	INSERT,SRAIL,BLIND1-15/16PVDF*		1.
4	501019	GEAR,MITER,SPUR,13T,PVDF .920*		1.

### 9.3.14 PLUMBING,POS607

#### 503105 PLUMBING,POS607

ITEM_#_ON			
DRAWING	PART_NUMBER	DESCRIPTION	QUANTITY
1	503146	PLUMBING,POS607,LOWER RACK	1.
2	503165	PLUMBING,POS607,UPPER RACK	1.
3	503166	PLUMBING,POS607,DRAIN	1.

### 9.3.15 PLUMBING, POS607, LOWER RACK

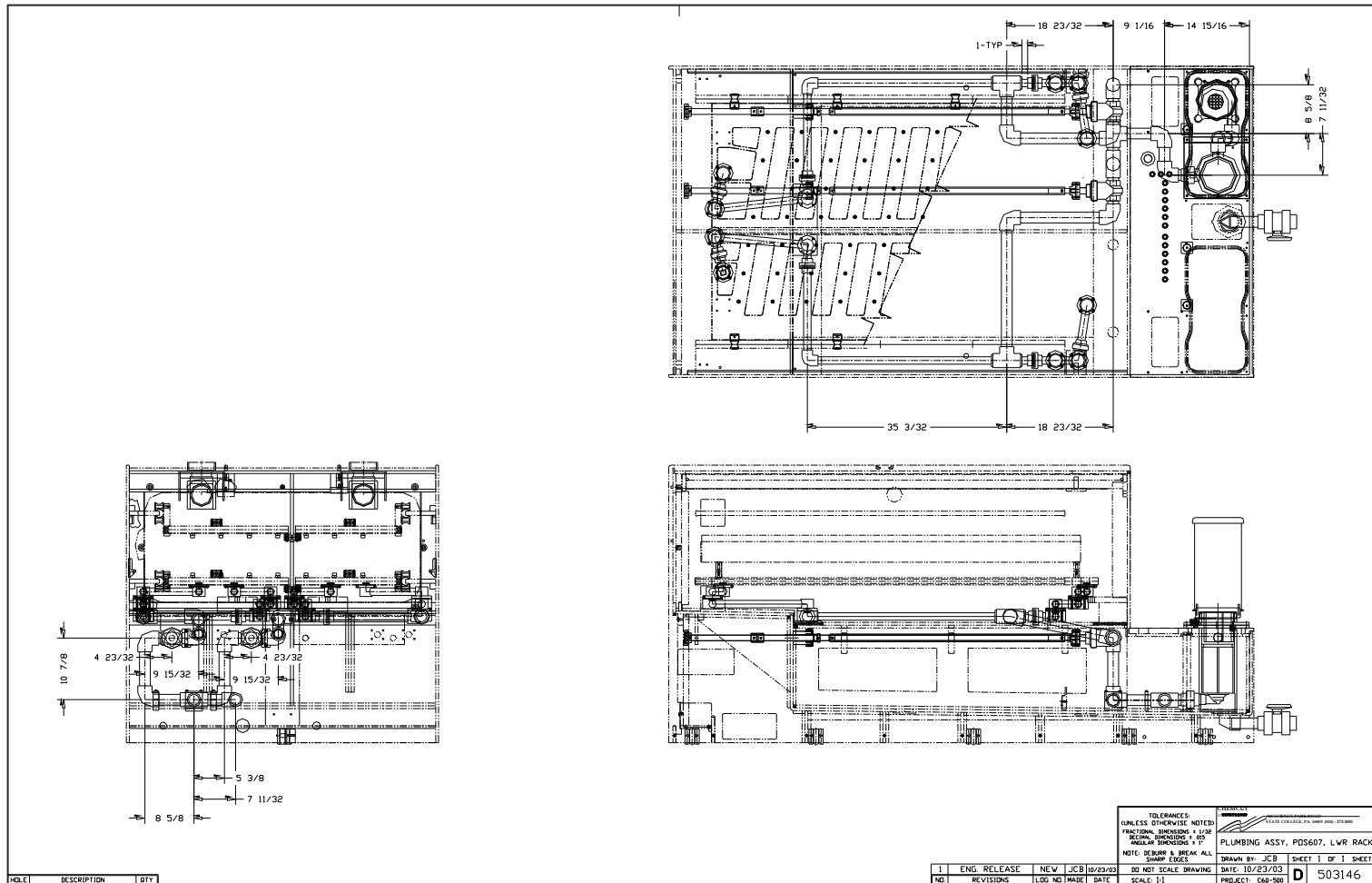

**503146 PLUMBING,POS607,LOWER RACK**

ITEM_#_ON	DRAWING	PART_NUMBER	DESCRIPTION	QUANTITY
1		501045	FILTER/CARAPACE,POS***,PVC	1.
2		002401	ELBOW,90,PVC,1-1/2SOC,SCH80 S	10.
3		025781	TEE,PVC,1-1/2SOC,SCH80 S	3.
4		143841	VALVE,GATE,PVC,1-1/2SOC S	2.
5		153955	BUSHING,PVC,1-1/2MSX1FS S	4.
6		151193	CLAMP,TRIM-FIT,1",PVC/TI	4.
7		002133	PIPE,PVC,1-1/2IN,SCH80 S	12.000
8		153684	CLAMP,TRIM-FIT,1-1/2,PVC/TI	2.
9		503144	HANDLE INSTL,POS60	2.
10		147259	CLAMP,PVC/TI,1-1/2,SCH80 FIT	3.
11		003023	BOLT,HEX,TI,1/4-20X1-1/2	4.
12		003024	BOLT,HEX,TI,1/4-20X1	4.
13		069565	PVC,1/2 X 1/2	24.000
14		002155	PIPE,PVC,1IN,SCH80 S	10.000
15		503157	HOSE ASSY,MECHANICAL,PVC,POS60	4.
16		002710	SCREW,RD,TI,1/4-20 X 1"	8.



### 9.3.16 PLUMBING, POS607, UPPER RACK

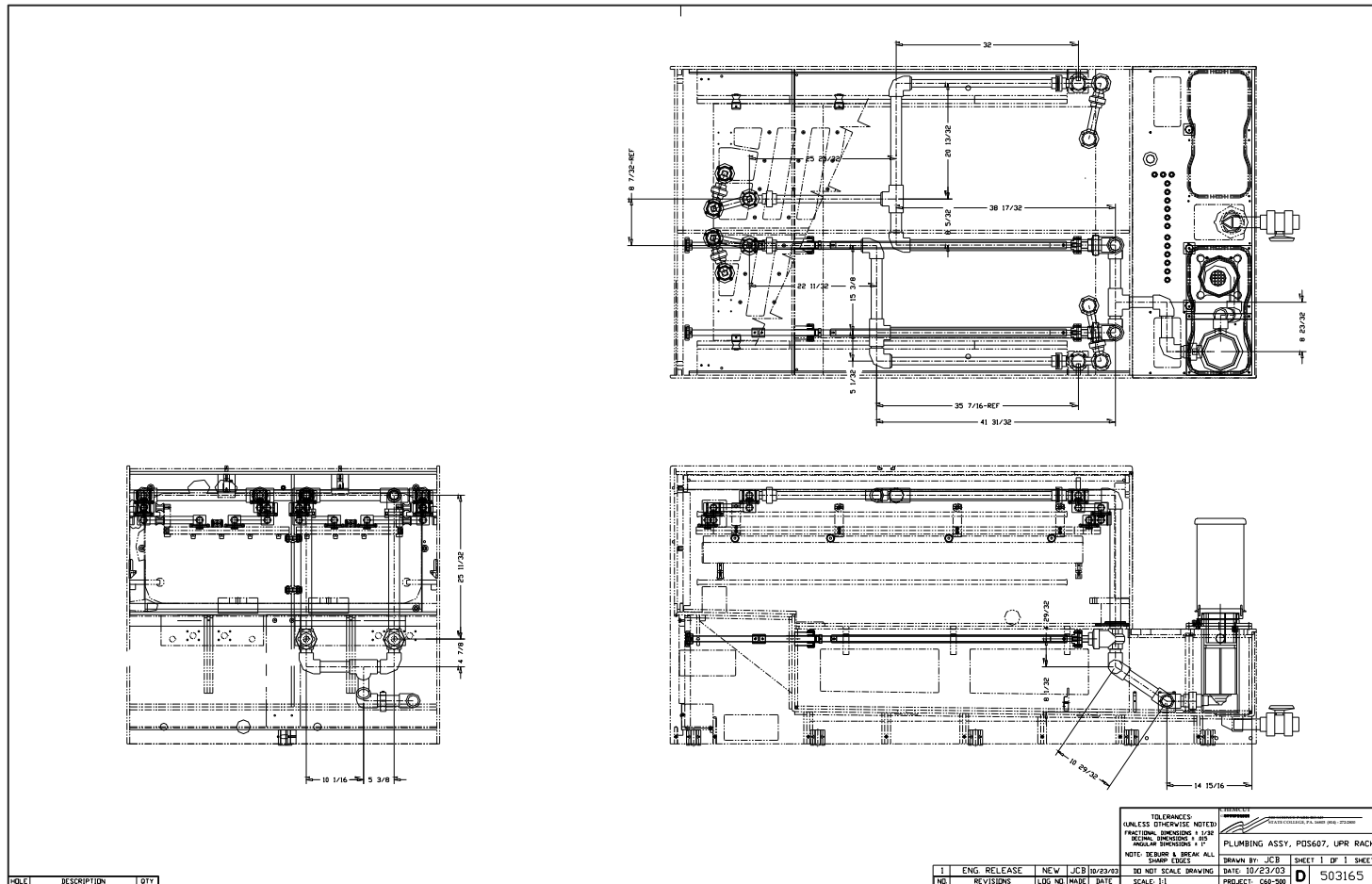

**503165 PLUMBING,POS607,UPPER RACK**

ITEM_#_ON	DRAWING	PART_NUMBER	DESCRIPTION	QUANTITY
1		501045	FILTER/CARAPACE,POS***,PVC	1.
2		002401	ELBOW,90,PVC,1-1/2SOC,SCH80 S	10.
3		025781	TEE,PVC,1-1/2SOC,SCH80 S	3.
4		143841	VALVE,GATE,PVC,1-1/2SOC S	2.
5		153955	BUSHING,PVC,1-1/2MSX1FS S	4.
6		151193	CLAMP,TRIM-FIT,1",PVC/TI	4.
7		002133	PIPE,PVC,1-1/2IN,SCH80 S	12.000
8		153684	CLAMP,TRIM-FIT,1-1/2,PVC/TI	2.
9		503144	HANDLE INSTL,POS60	2.
10		147259	CLAMP,PVC/TI,1-1/2,SCH80 FIT	3.
11		003023	BOLT,HEX,TI,1/4-20X1-1/2	4.
12		003024	BOLT,HEX,TI,1/4-20X1	4.
13		069565	PVC,1/2 X 1/2	24.000
14		002155	PIPE,PVC,1IN,SCH80 S	10.000
15		503157	HOSE ASSY,MECHANICAL,PVC,POS60	4.
16		002710	SCREW,RD,TI,1/4-20 X 1"	8.
17		145520	SUPPORT,PLUMB,1-1/2,OS	2.

**9.3.17 PLUMBING,POS607,DRAIN**

**503166 PLUMBING,POS607,DRAIN**

ITEM_#_ON				
DRAWING	PART_NUMBER	DESCRIPTION		QUANTITY
1	018454	VALVE,BALL,PVC,1-1/2NPT,TU V S		1.
0	106242	NIPPLE,PVC,1-1/2"(TXS)5"LG		1.



**138498 PUMP SUBASSY,P-55J-C1**

ITEM_#_ON	DRAWING	PART_NUMBER	DESCRIPTION	QUANTITY
0		145430	PUMP SUBASSEMBLY(REF.DWG)	0.0
0		147234	SPECIFICATION,PUMPS,CHEMCUT	0.0
1		025261	MOTOR,AC,7-1/2HP(60HZ)5HP(50HZ	1.
2		080073	COWL,MOTOR,LARGE,3,5,7-1/2 HP	1.
3		037989	SCREW,SELF TAP,10-32X3/4	1.
4		084594	COVER,HOLE,BLACK,1 INCH	1.
5		133714	MOUNT,MOTOR,RPP,P-25	1.
6		043122	BOLT,HEX,SST316,1/2-13X1-1/4	4.
7		040328	WASHER,FLAT,TI,1/2"NOM	4.
8		043089	WASHER,LOCK,SST316,1/2"NOM	4.
9		163463	SHAFT,PUMP,TI,1-1/2DIA X7/8-14*	1.
11		105644	COLUMN ASSY,PUMP,PPL (SH)	1.
12		105492	SLEEVE,PUMP COLUMN,TFE,P-24/25	1.
13		031925	SEAL,O-RING,2-225,EPDM,BLACK	1.
14		145908	PLATE,PUMP,OS,0DEG,1-1/2"	1.
15		075961	KEY,"L",TI,1/4X1/4X1"LG	1.
16		104608	COLLAR,SHAFT,SST303,1-1/2ID	1.
17		029171	COLLAR,MODIFIED	1.
18		170012	SEAL,O-RING,2-365,EPDM,BLACK	1.
19		126509	IMPELLER,TI,7/8-14,5.75X5.75,T	1.
20		135380	BOLT,HEX,TI,1/4-20X 3/4	1.
21		015811	WASHER,FLAT,TI,9/32IDX1-1/4OD	1.
22		149058	SEAL,O-RING,2-360,EPDM,BLACK	1.
23		003069	LABEL,MYLAR,(PUMP)	1.
24		014133	LABEL,WARNING,(PUMP ROTATION)	1.
25		015392	LABEL,IDENT,(ROTATION,R-L)	1.
26		145721	LABEL,"CAUTION HOT"	1.

### 9.3.19 Pump Specifications

<b>B</b>	147234						
<h2 style="margin: 0;">Pump Specifications</h2>							
<h3 style="margin: 0;">CHEMCUT Pumps</h3>							
P/N 043122    1/2" stainless bolts into mount P/N 133714 on P/N 159000, 025261 motors 210 IP. P/N 003785    3/8" stainless bolts into mount P/N 105642 on P/N 018336, 018277, 005088, 079177 motors 165 IP. All shaft collar bolts 150 IP. P/N 015809    1/4-20 Ti bolt for all impellers 90 IP. P/N 041760    3/8" Ti bolts into P/N 046276 columns 160 IP P/N 003032    1/4-20 Ti nuts on all pump housings 45 IP. P/N 041760    3/8" Ti bolts into P/N 041741 mount to P/N 141017 column 160 IP. P/N 023736    3/8" Ti bolts into P/N 040736 column 160 IP. P/N 040327    1/2" Ti bolts into P/N 046420, 040325 column 200 IP. P/N 089736    1/2" Ti bolts into P/N 084577, etc. (large carapace) 125 IP. P/N 003645    3/8" Ti bolts into P/N 110607, etc. (small carapace) 100 IP.							
<h3 style="margin: 0;">Finish Thompson Pumps</h3>							
KC-6, 8, 10 1/4-20 SST Setscrews 65 IP 3/8" SST bolt into motor 130 IP Phillips head screws in housing 30 IP. KC-11 3/8" SST setscrew 200 IP 3/8" socket head bolts into motor face 130 IP Phillips head screws in housing 30 IP							
					TOLERANCES: (UNLESS OTHERWISE NOTED) FRACTIONAL DIMENSIONS ± 1/32 DECIMAL DIMENSIONS ± .015 ANGULAR DIMENSIONS ± 1°		
					NOTE: DEBURR & BREAK ALL SHARP EDGES		
					DO NOT SCALE DRAWING		
					SCALE: X		
					SPECIFICATIONS, PUMPS, REFERENCE		
					DRAWN BY: KV    PROJECT: PUMPS DATE: 3.14.01    SHEET 1 OF 1 SHEETS		
					APPV'D BY: <b>B</b> 147234 DATE:		
HOLE	DESCRIPTION	QTY	3	CLEANUP	DUI	KV	6/18/01
NO.	REVISIONS	LOG NO.	APP'D	MADE	DATE		

**9.3.20 COOLING,POS607**

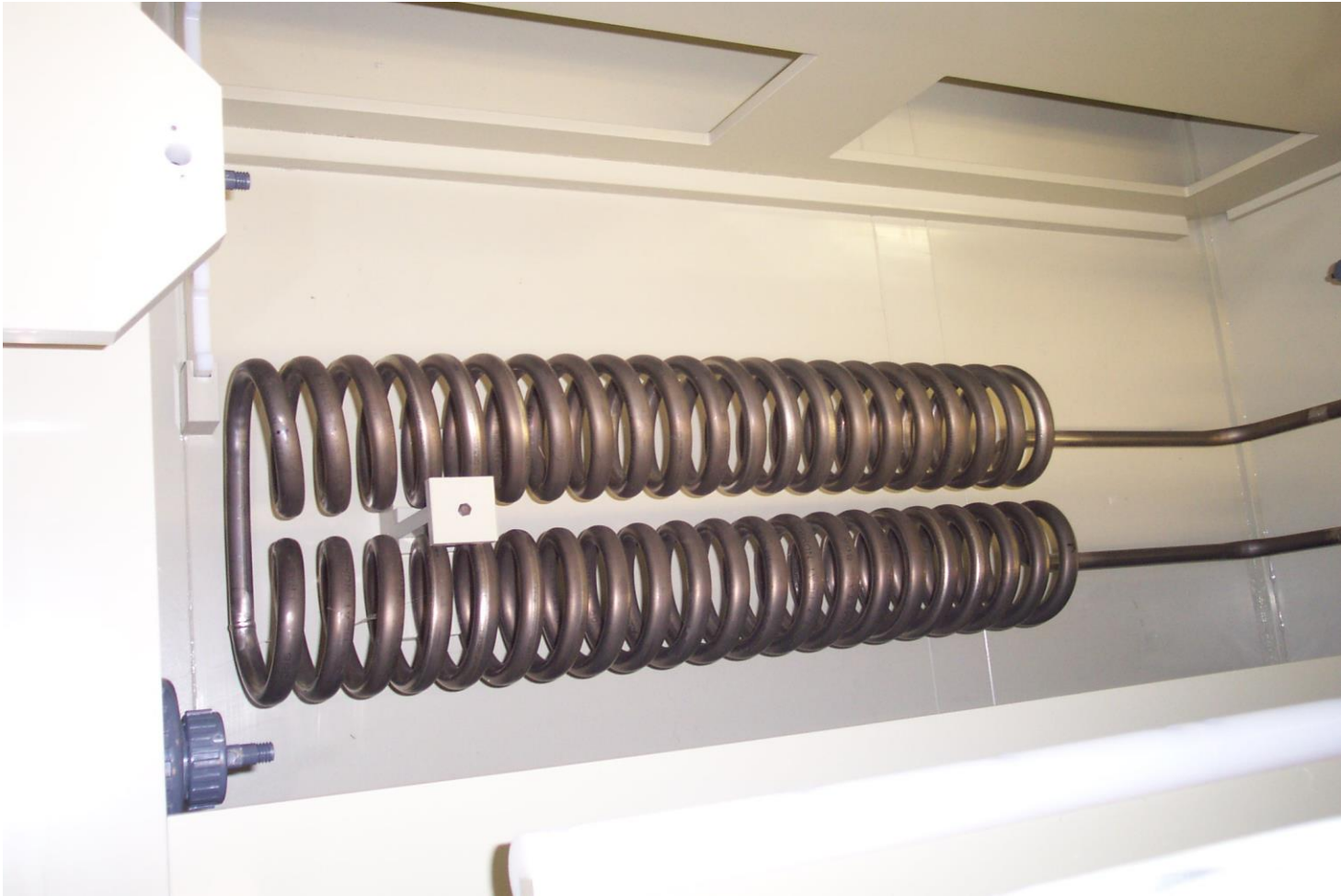

COOLING, POS607





**503099 COOLING,POS607**

ITEM_#_ON	DRAWING	PART_NUMBER	DESCRIPTION	QUANTITY
1		176034	COIL,COOLING,TI,DPEM	1.
2		141853	GASKET,COOLING COIL,1.5 X 2	2.
3		003056	WASHER,FLAT,TI,1/4 NOM	8.
4		003032	NUT,HEX,TI,1/4-20	8.
5		014819	CLAMP,COIL,PVC,3/4IN	3.
6		023837	UNION,PVC,3/4NPT,SCH80,EPDM S	1.
7		028992	ELBOW,90,PVC,3/4SOC,SCH80 S	1.
8		011905	VALVE,SOL,PAINT,BRS,3/4NPT,N/C	1.
9		002165	PIPE,PVC,3/4IN,SCH80 S	7.750
10		150674	CLAMP,TRIM-FIT,3/4",PVC	1.
11		141381	COOLING COIL,DRAIN SUPPORT	1.
12		069565	PVC,1/2 X 1/2	2.500
13		002380	ELBOW,90,PVC,3/4NPT,SCH80 S	1.
14		080302	UNION,PVC,3/4SOC,SCH80,VITON S	2.
15		080063	ELBOW,45,PVC,3/4SOC,SCH40	2.

**9.3.21 GAUGE INSTL,POS607,0-60 (40)**

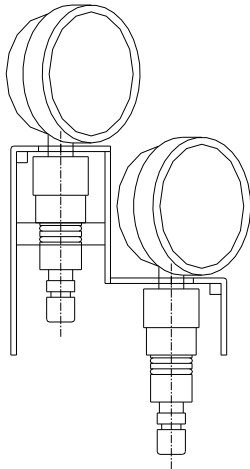
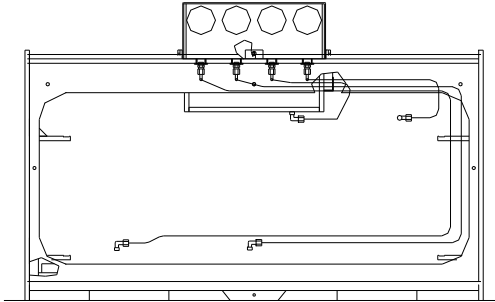
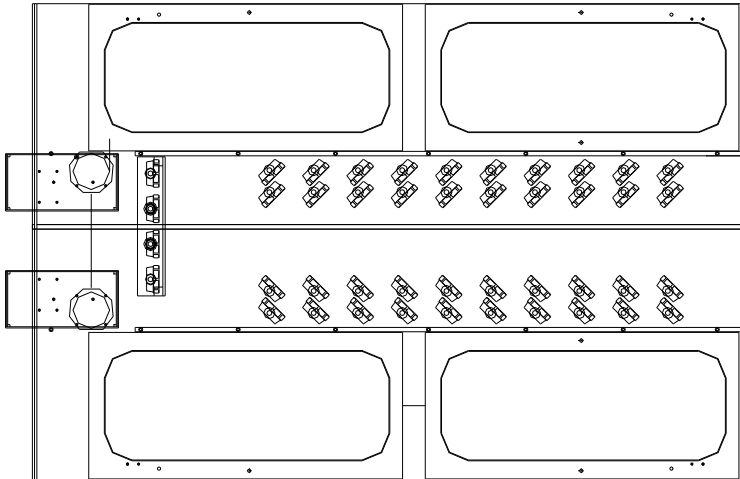

**503113 GAUGE INSTL,POS607,0-60 (40)**

ITEM_#_ON	DRAWING	PART_NUMBER	DESCRIPTION	QUANTITY
0		103650	GAUGE,PRESS,0-60/4BAR,W/ISOL	40.
0		003833	CONNECTOR,MALE,PP,1/4TX1/4NPT	40.
0		017905	INSERT,PP,1/4OD TUBE	80.
0		011974	TUBING,PE,1/4"ODX.040 W	450.000
0		016108	ELBOW,MALE,PP,1/4TX1/4NPT	40.
0		137355	SHEET,PVC,EUROGRY,1/2X51X122IN	8.000
0		137353	SHEET,PVC,EUROGRY,1/8X48X96IN	8.000
0		002712	SCREW,RD,TI,1/4-20 X 1/2	40.
0		025980	RETAINER,TUBE,PVC,MOLDED	120.
14		501791	INSERT,MALE,1/8"ID,PPL	40.
15		501792	INSERT,FEMALE,1/8"ID,PPL	40.
0		144178	THUMBSCREW,TI,1/4-20X1-1/2,CAP	8.
0		023353	PIN,GRAPHITE,1/4ODX1LG	16.
0		133930	INSERT,THD,TI,1/4-20X.472	8.
0		002709	SCREW,RD,TI,1/4-20 X 1-1/2"	16.
21		503216	COVER ASSY,20 PRESSURE GAUGE	2.
22		503218	COUPLING ASSY,10 HOSE	4.
23		012803	GASKET,RD,TY,7/32"IDX1"ODX1/4	20.

### 9.3.22 GAUGE INSTL,PRESS,PEM,(2)

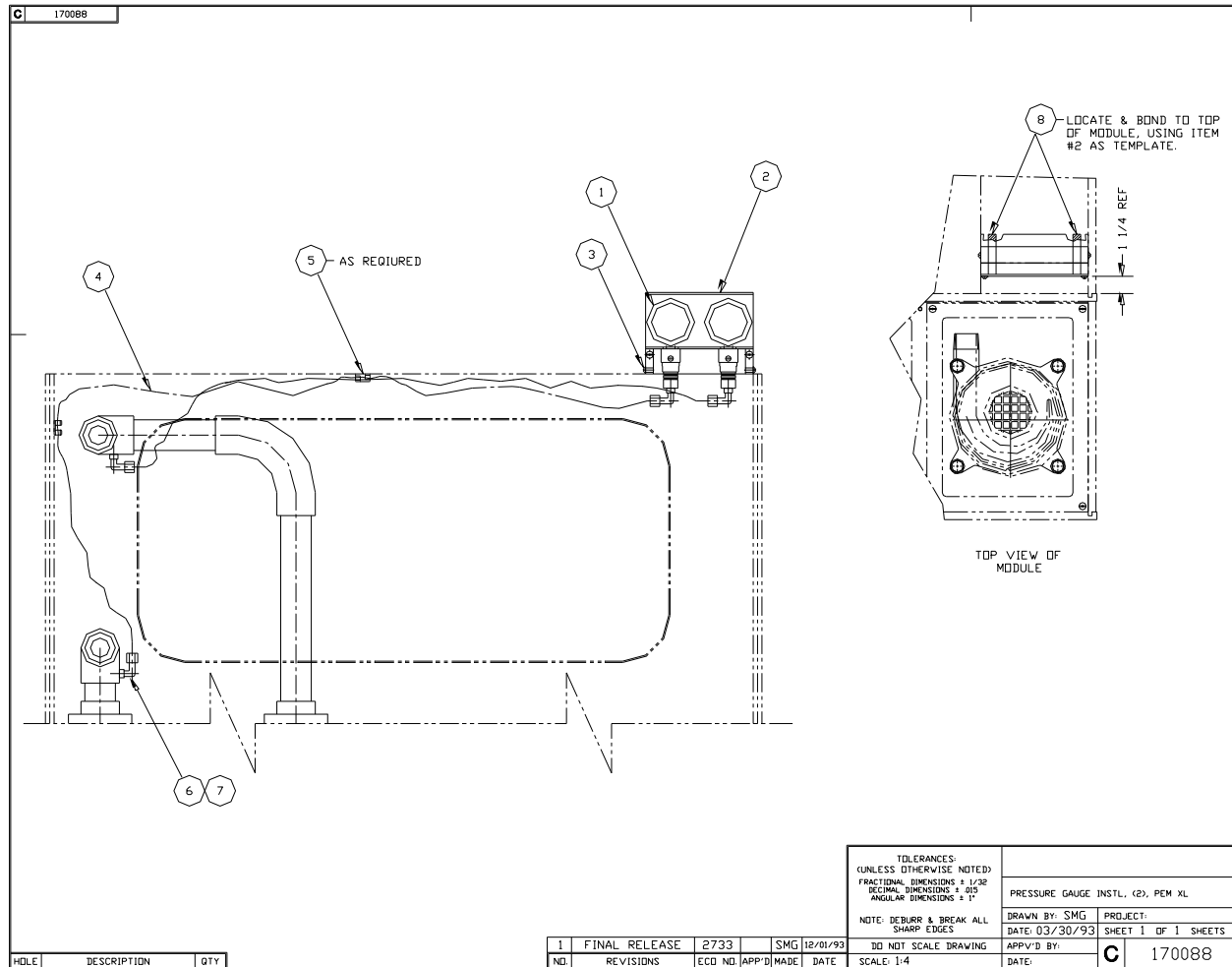

**170088 GAUGE INSTL,PRESS,PEM,(2)**

ITEM_#_ON	DRAWING	PART_NUMBER	DESCRIPTION	QUANTITY
1		103650	GAUGE,PRESS,0-60/4BAR,W/ISOL	2.000
2		170404	COVER ASSY,PG,PVC,(2)	1.000
3		002711	SCREW,RD,TI,1/4-20 X 3/4"	2.000
4		011974	TUBING,PE,1/4"ODX.040 W	12.000
5		025980	RETAINER,TUBE,PVC,MOLDED	2.000
6		016108	ELBOW,MALE,PP,1/4TX1/4NPT	4.000
7		017905	INSERT,PP,1/4OD TUBE	4.000
8		069565	PVC,1/2 X 1/2	2.625
8		069565	PVC,1/2 X 1/2	2.625

### 9.3.23 NOZZLE INSTL,EDGE ETCH

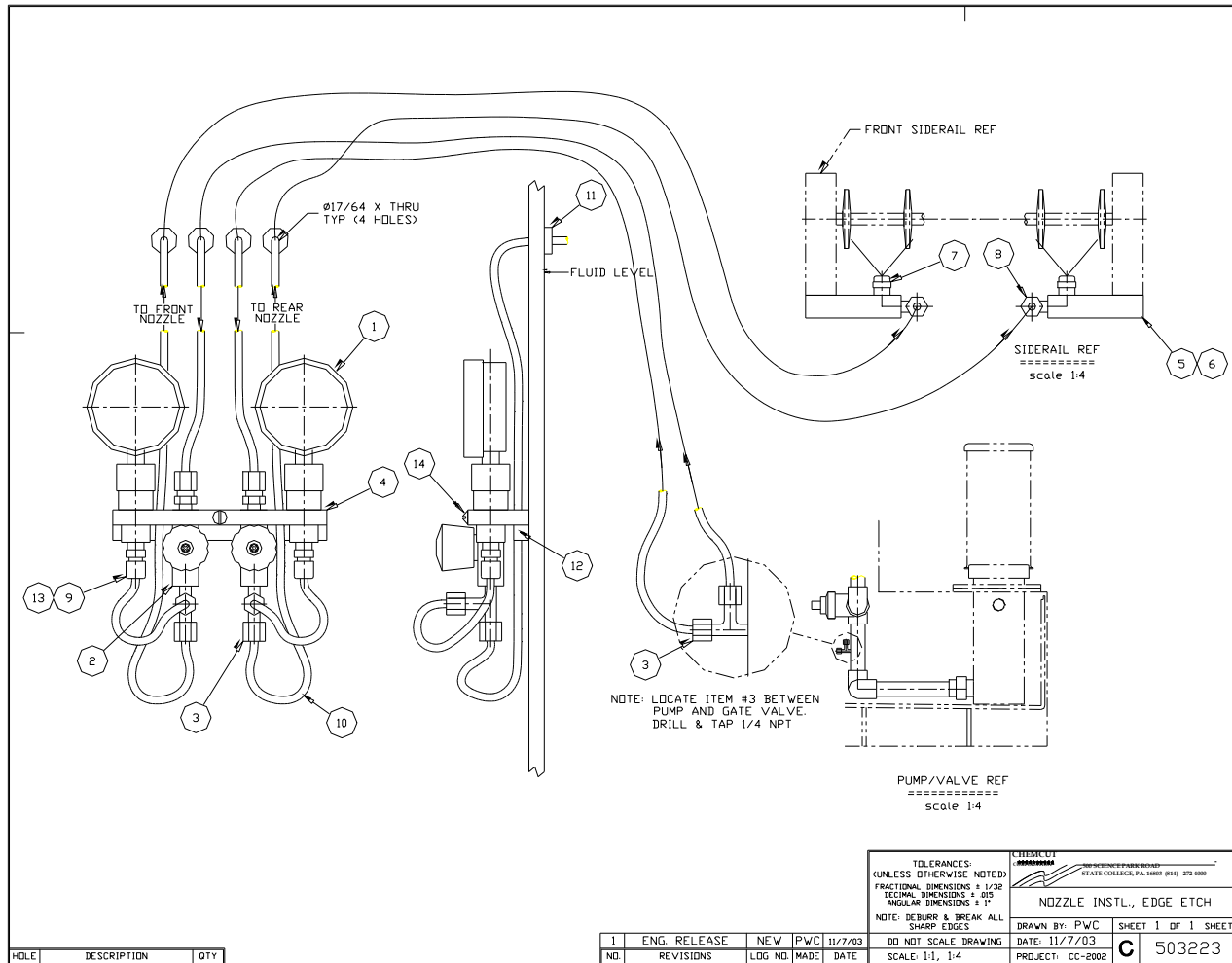

503223 NOZZLE INSTL,EDGE ETCH

ITEM_#_ON	DRAWING	PART_NUMBER	DESCRIPTION	QUANTITY
1	103650	GAUGE,PRESS,0-60/4BAR,W/ISOL		2.
2	156718	VALVE,NEEDLE,PVC,1/4NPT		2.
3	106935	TEE,MALE RUN,PPL,1/4NPTX1/4T		3.
4	503225	CLAMP,MTG,GAUGE/VALVE		1.
5	503224	BLOCK,MTG,NOZZLE		2.
6	002710	SCREW,RD,TI,1/4-20 X 1"		2.
7	149941	NOZZLE,SCRD,PVDF,.75GPM,80DEG		2.
8	016108	ELBOW,MALE,PP,1/4TX1/4NPT		2.
9	003833	CONNECTOR,MALE,PP,1/4TX1/4NPT		4.
10	011974	TUBING,PE,1/4"ODX.040 W		25.000
11	012803	GASKET,RD,TY,7/32"IDX1"ODX1/4		4.
12	069565	PVC,1/2 X 1/2	7.000	
13	017905	INSERT,PP,1/4OD TUBE		12.
14	002709	SCREW,RD,TI,1/4-20 X 1-1/2"		1.

### 9.3.24 HEAT,6X6KW,440-480V,TI,M BLD

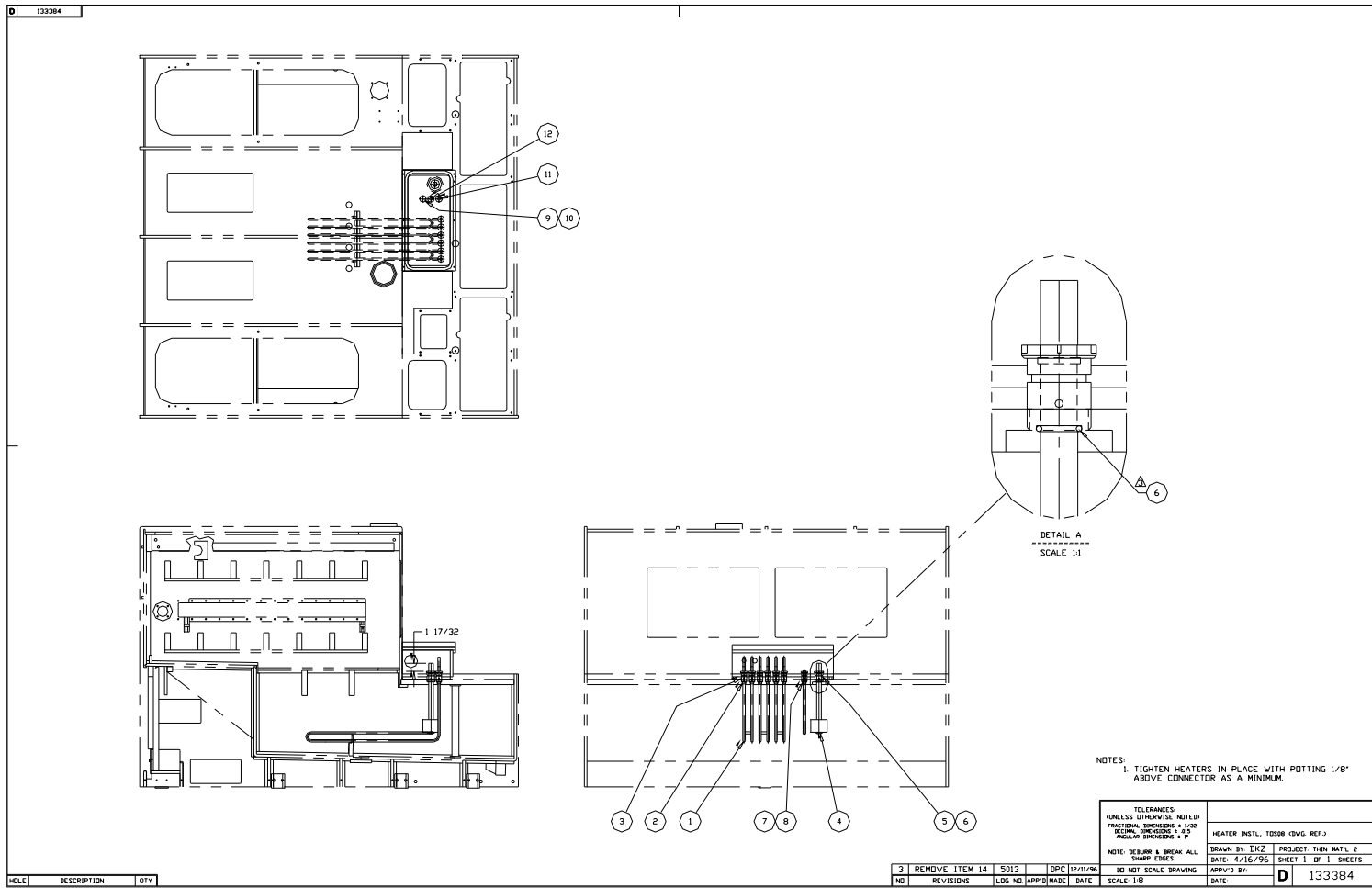



**503126 HEAT,6X6KW,440-480V,TI,M BLD**

ITEM_#_ON	DRAWING	PART_NUMBER	DESCRIPTION	QUANTITY
0		133384	HEATER INSTL,TOS08(REF DWG)	0.
1		128351	HEATER,IMM,6KW,480V,STUD,TI	6.
2		149937	INSERT,TPE,.440,CORD,MOLDED	12.
3		120526	CONNECTOR,BOX,HEATER,PP,1/2	12.
4		161614	SWITCH,LIQUID LEVEL ACTUATOR	1.
5		117113	CONNECTOR ASSY,BOX,PP,1/2PIPE	1.
6		149368	SEAL,O-RING,2-211,EPDM	1.
7		117111	CONNECTOR,BOX,PROBE,PP,1/2	2.
8		046328	INSERT,TPE,1/2,CORD,MOLDED	2.
9		117126	CONNECTOR,BOX,BLANK,PP	2.
10		046330	INSERT,TPE,7/32,CORD,MOLDED	2.
0		164422	PROBE,T-S/OT,132 F,14 IN,POLY	1.000
13		133651	BOOT,HEATER TERMINAL COVER	12.



**501676      JCT BOX INSTL,AIRGAP,POS06**

ITEM\_#\_ON

DRAWING	PART_NUMBER	DESCRIPTION	QUANTITY
0	501677	BOX ASSY,AIRGAP,POS06/08	1.0

### 9.3.26 RECIRC PUMP,(2)POS,3HP,W/FEEDS

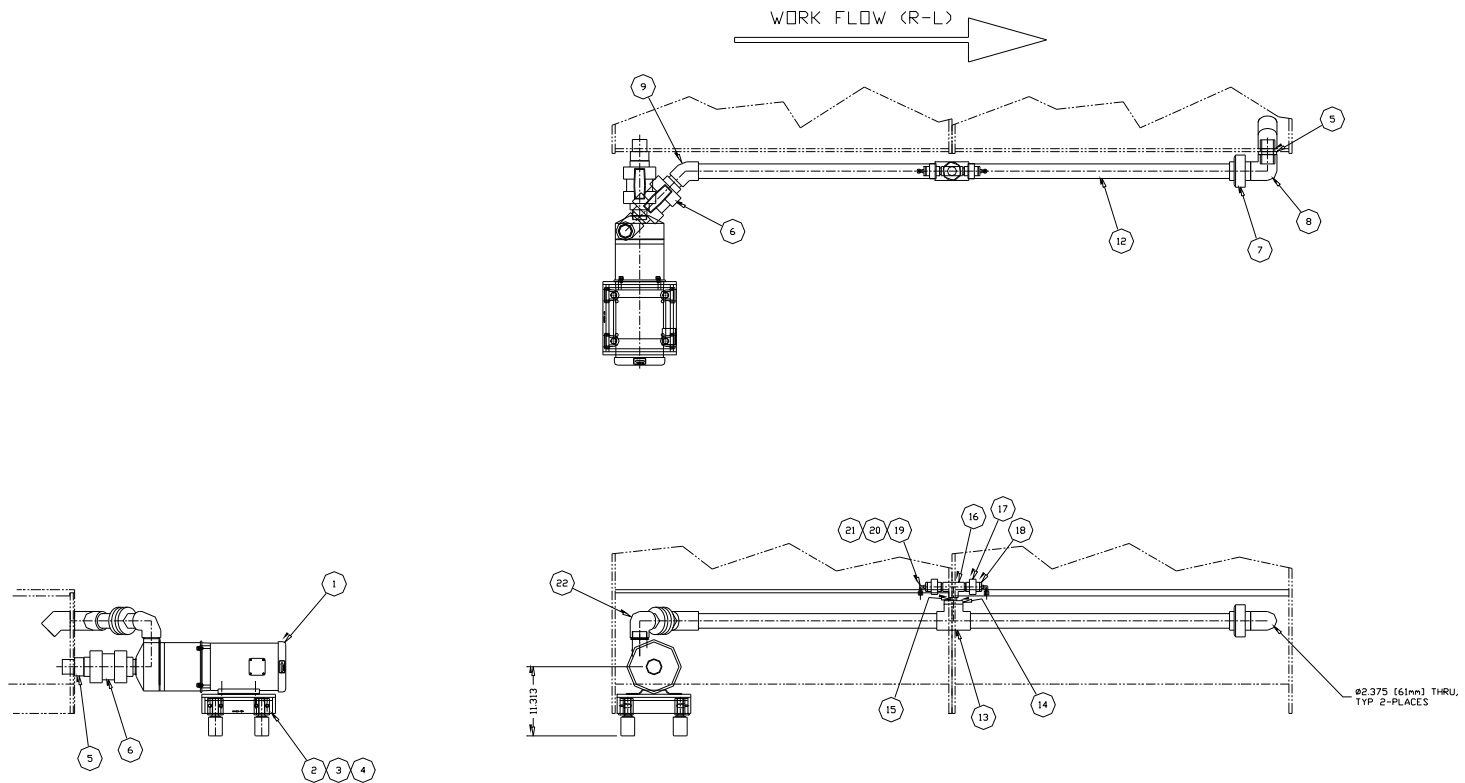

RECIRC INSTL, POS, 3-HP, W/FEEDS

502817

**502817 RECIRC PUMP,(2)POS,3HP,W/FEEDS**

ITEM_#_ON	DRAWING	PART_NUMBER	DESCRIPTION	QUANTITY
1		147075	PUMP,CENT,MD,3HPCE,KC22,NPT,RP	1.
2		135409	STAND,RECIRC,PUMP,OS,3 1/8"	1.
3		003010	BOLT,HEX,TI,3/8-16X1	4.
4		009314	WASHER,FLAT,TI,3/8"NOM	4.
5		135302	ADAPTER,PLUMBING,THRU WALL,2"	2.
6		018455	VALVE,BALL,PVC,2NPT,TU	2.
7		118537	UNION,PVC,2SOC,SCH80,EPDM	1.
8		015637	ELBOW,90,PVC,2SOC,SCH80 S	4.
9		034708	ELBOW,45,PVC,2SOC,SCH80	1.
10		153825	CLAMP,TRIM-FIT,2",PVC	2.
12		006724	PIPE,PVC,2IN,SCH80	10.000
13		025778	TEE,PVC,2SOC,SCH80	1.
14		028990	BUSHING,PVC,2MSX3/4FS	1.
15		002165	PIPE,PVC,3/4IN,SCH80 S	1.
16		028991	TEE,PVC,3/4SOC,SCH80 S	1.
17		118535	UNION,PVC,3/4SOC,SCH80,EPDM S	2.
18		142520	BUSHING,PVC,3/4MSX1/4FPT	2.
19		016108	ELBOW,MALE,PP,1/4TX1/4NPT	2.
20		017905	INSERT,PP,1/4OD TUBE	2.
21		011974	TUBING,PE,1/4"ODX.040 W	20.000
22		023949	ELBOW,90,PVC,2NPTX2SOC	1.

### 9.3.27 INTERCONNECT,SUMP,POS (4-EA)

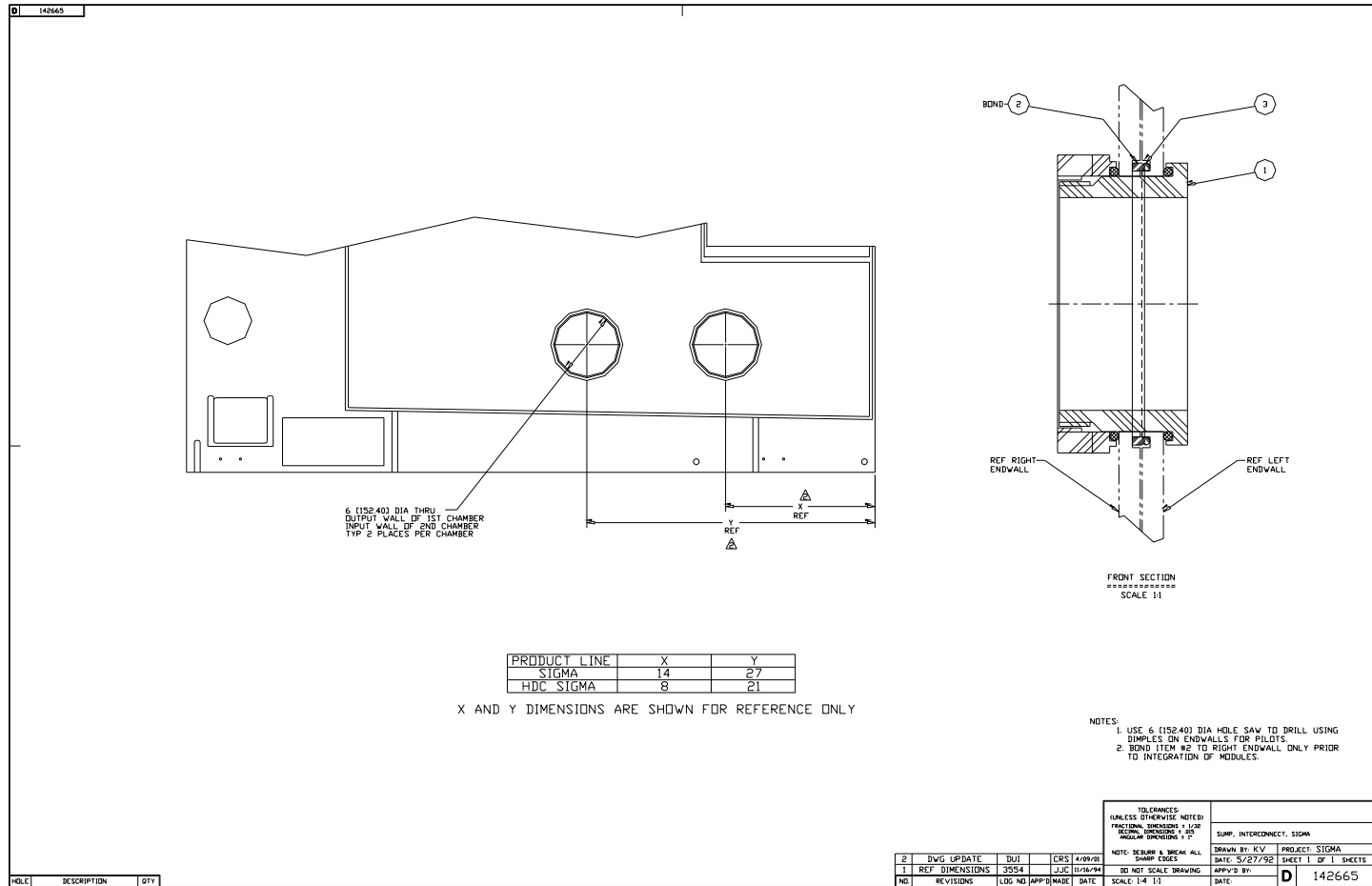

503137 INTERCONNECT,SUMP,POS (4-EA)

ITEM_#_ON	DRAWING	PART_NUMBER	DESCRIPTION	QUANTITY
0	T-2984		TOOL,WRENCH SPANNER,2 PIECES	0.
1	142665		SUMP INTERCONNECT,SIGMA,(2)	2.

142665 SUMP INTERCONNECT,SIGMA,(2)

ITEM_#_ON	DRAWING	PART_NUMBER	DESCRIPTION	QUANTITY
1	084601		ADAPTER ASSY,SUMP INTERCONNECT	2.
2	143114		RING,SUMP INTERCONNECT,OS	2.
3	022672		SEAL,O-RING,2-362,EPDM,BLACK	2.

### 9.3.28 SUPPLY,PVC SOL,1/2",POS

#### 503156 SUPPLY,PVC SOL,1/2",POS

ITEM_#_ON	DRAWING	PART_NUMBER	DESCRIPTION	QUANTITY
1		148694	COUPLING,PVC,1/2SOC,MOD	1.0
2		002176	PIPE,PVC,1/2IN,SCH80	1.0
3		118109	ELBOW,90,PVC,1/2SOC,SCH80 S	1.0
4		118534	UNION,PVC,1/2SOC,SCH80 S	1.0
5		163838	VALVE,SOL,PVC,1/2NPT,N/C,2WAY*	1.0



## 9.4 POS607 Ferric Chloride Etch

### 9.4.1 POS607M-1 POS607,MEC PARTS,NO/AIR SEAL

ITEM_#_ON	DRAWING	PART_NUMBER	DESCRIPTION	QUANTITY
0	503094	POS607 MOD ASSY,NO/AIR SEAL		1.
0	503095	MODULE INT,POS607,TI,N/AIRSEAL		1.

### 9.4.2 POS607 MOD ASSY,NO/AIR SEAL

#### 503094 POS607 MOD ASSY,NO/AIR SEAL

ITEM_#_ON	DRAWING	PART_NUMBER	DESCRIPTION	QUANTITY
0	503056	CHAMBER,POS607,NO/AIR SEAL		1.
0	503105	PLUMBING,POS607		1.
3	503106	SPRAYRACK INSTL,POS607,(40-PG)		1.
0	503097	DRIVE INSTL,OSCILLATION,POS607		2.
0	503099	COOLING,POS607		2.
0	503107	JCT BOX INSTL,AIRGAP,POS607		1.
0	131577	COVER INSTL,FRONT,TOS*06		1.
0	144090	COVER INSTL,OSC,OS		2.
0	501748	COVER,SUMP ACCESS/SAMPLE,POS		1.
0	501749	COVER,SUMP ACCESS,POS		2.
0	600404	PLUG,PORT,PVC,XLI		1.
0	170088	GAUGE INSTL,PRESS,PEM,(2)		2.
	136179	LABELS,SIGMA,TOS,STD		1
	502809	BAG,FILTER,80MIC,PLYESTR,(2)		1

502817	RECIRC PUMP,(2)POS,3HP,W/FEEDS	1
503113	GAUGE INSTL,POS607,0-60 (40)	1
503126	HEAT,6X6KW,440-480V,TI,M BLD	1
503129	CNVR,ROLL,POS607,LR,N/OUT ROLL	1
503135	PUMP,2X7.5,P-55CJ-CI,TI IMPELL	1
503136	NOZZLE,1.5GPM,073711,SCRD(140)	1
503137	INTERCONNECT,SUMP,POS (4-EA)	1
503156	SUPPLY,PVC SOL,1/2",POS	1
503223	NOZZLE INSTL,EDGE ETCH	1

### 9.4.3 MODULE INT,POS607,TI,N/AIRSEAL

#### 503095 MODULE INT,POS607,TI,N/AIRSEAL

ITEM_#_ON	DRAWING	PART_NUMBER	DESCRIPTION	QUANTITY
0	503108	DOOR INSTL,FRONT,POS*07,N/AIRS		1.
0	503192	DOOR INSTL,REAR,POS*07,N/AIRS		1.
0	503109	LID INSTL,TOP POS607,N/AIRSEAL		1.
0	503096	GASKET,CNVR,P-SIGMA,60,TPE55A		1.
0	503104	ANGLE,OPENING,P-SIGMA,60,TI		4.
0	141115	BOLT,HEX,TI,1/4-20X1-1/4		58.
0	003032	NUT,HEX,TI,1/4-20		58.
0	142534	PIN,GRAPHITE,1/4ODX3/4LG		2.
0	143787	LABEL,UPPER,INPUT		1.
0	143788	LABEL,UPPER,OUTPUT		1.
0	143789	LABEL,LOWER,INPUT		1.
0	143790	LABEL,LOWER,OUTPUT		1.
0	049817	ADAPTER,VENT,PVC,MOLDED,4"		2.
0	501035	PLATE,CONN,FRONT,P-SIGM,TI		2.
0	501036	PLATE,CONN,REAR,P-SIGMA,TI		2.

9.4.4 DRIVE INSTL, OSCILLATION, POS607

503097 No Drawing



**503097 DRIVE INSTL,OSCILLATION,POS607**

ITEM_#_ON	DRAWING	PART_NUMBER	DESCRIPTION	QUANTITY
1		144240	MOTOR,GEAR,DC,1/4HP,68RPM,RITE	1.
2		144630	CLAMP ASSY,MOTOR,OSC,PVC,TOS	1.
3		003024	BOLT,HEX,TI,1/4-20X1	4.
4		003056	WASHER,FLAT,TI,1/4 NOM	4.
5		501596	BUSHING,UPPER,OSC,POS	1.
6		069565	PVC,1/2 X 1/2	12.000
7		501718	BEARING,LOWER,OSC,UHMW	1.
8		031243	PIN,TI,.125ODX1LG	2.
9		144243	COUPLING,DRIVE,OSC,OS	1.
10		148916	KEY,SQ TI,3/16X1-1/2LG	1.
11		029163	SETSCREW,TI,1/4-20X1/4",CUP PT	2.
12		503085	PLATE,SEAL,OSCILLATION,POS,MOD	1.
12		503092	BRACKET,SHAFT,OSC,LWR,POS607	0.00000
13		159857	SEAL,O-RING,2-241,EPDM,BLACK	2.
14		002711	SCREW,RD,TI,1/4-20 X 3/4"	4.
15		082298	SEAL,V-RING,CVU-1220,PTFE	1.
16		148952	CAP,BEARING,PVC	1.
17		502731	SHAFT ASSY,OSC,POS	1.
18		501080	CAM,OSCILLATION,POS	2.
19		003008	BOLT,HEX,TI,3/8-16X1-1/2	2.
20		003012	NUT,HEX,TI,3/8-16	2.

**9.4.5 SPRAYRACK INSTL,POS607,(40-PG)**

**Lower Rack Shown**



**503106      SPRAYRACK INSTL,POS607,(40-PG)**

ITEM_#_ON			
DRAWING	PART_NUMBER	DESCRIPTION	QUANTITY
0	503114	SPRAYRACK ASSY,UP/LEFT,POS607	1.
0	503141	SPRAYRACK ASSY,LOW/LEFT,POS607	1.
0	503151	SPRAYRACK ASSY,UP/RIGHT,POS607	1.
0	503169	SPRAYRACK ASSY,LOW/RHGT,POS607	1.
5	503120	PIN,RACK SUPPORT ROLLER	8.
6	503119	ROLLER,RACK SUPPORT	16.
7	130994	WASHER,HDPE,.380IDX1ODX1/16THK	16.
8	503121	COLLAR,LOCK,RACK ROLLER	8.

**9.4.6 SPRAYRACK ASSY,UP/LEFT,POS607**



**503114      SPRAYRACK ASSY,UP/LEFT,POS607**

ITEM_#_ON	DRAWING	PART_NUMBER	DESCRIPTION	QUANTITY
1		503115	PLATE,TOP,UPPER RACK,LFT,40 NZ	1.
2		503116	PLATE,BOT,UPPER RACK,LFT,40 NZ	1.
0		700404	SEAL,O-RING,EPDM,1/8 X RANDOM	50.000
9		501073	ROLLER GUIDE,SPRAY RACK	8.
10		502552	PIN,ROLLER,SPRAYRACK	8.
11		002710	SCREW,RD,TI,1/4-20 X 1"	10.
12		503128	BLOCK,ROLLER MTG,OFFSET,POS607	4.
13		003029	SCREW,RD,TI,1/4-20 X 1-1/4"	10.
17		503132	BRACE,SPRAYRACK,UPR LFT,65.25"	1.
19		503134	BRACE,SPRAYRACK,TI,65.250"	1.
23		503138	BRACE,SPRAYRACK,TI,14.250"	20.
25		009356	BOLT,HEX,TI,1/4-20X1-3/4	115.
26		003032	NUT,HEX,TI,1/4-20	115.
28		501098	ADAPTER,ADJUST PLUG,1-14 UNF	10.
31		501097	PLUG,ADJUSTING,PPL,1-14 UNF	10.
37		145556	SCREW,FLAT,TI,10-24 X 3/4"	2.
39		503139	CAM LOCK INSTL,POS60*	1.
41		142534	PIN,GRAPHITE,1/4ODX3/4LG	2.
42		003056	WASHER,FLAT,TI,1/4 NOM	6.



**9.4.7 SPRAYRACK ASSY,LOW/LEFT,POS607**



**503141      SPRAYRACK ASSY,LOW/LEFT,POS607**

ITEM_#_ON	DRAWING	PART_NUMBER	DESCRIPTION	QUANTITY
1		503142	PLATE,TOP,LOWER RACK,LFT,40 NZ	1.
2		503143	PLATE,BOT,LOWER RACK,LFT,40 NZ	1.
0		700404	SEAL,O-RING,EPDM,1/8 X RANDOM	50.000
9		501073	ROLLER GUIDE,SPRAY RACK	8.
10		502552	PIN,ROLLER,SPRAYRACK	8.
11		002710	SCREW,RD,TI,1/4-20 X 1"	10.
12		503150	BLOCK,ROLLER MTG,SPRAYRACK,LWR	4.
13		003029	SCREW,RD,TI,1/4-20 X 1-1/4"	10.
17		503149	BRACE,SPRAYRACK,LWR LFT,65.25"	1.
19		503134	BRACE,SPRAYRACK,TI,65.250"	1.
23		503138	BRACE,SPRAYRACK,TI,14.250"	20.
25		009356	BOLT,HEX,TI,1/4-20X1-3/4	115.
26		003032	NUT,HEX,TI,1/4-20	115.
28		501098	ADAPTER,ADJUST PLUG,1-14 UNF	10.
31		501097	PLUG,ADJUSTING,PPL,1-14 UNF	10.
37		145556	SCREW,FLAT,TI,10-24 X 3/4"	2.
39		503139	CAM LOCK INSTL,POS60*	1.
41		142534	PIN,GRAPHITE,1/4ODX3/4LG	2.
42		003056	WASHER,FLAT,TI,1/4 NOM	6.

**9.4.8 SPRAYRACK ASSY,UP/RIGHT,POS607**

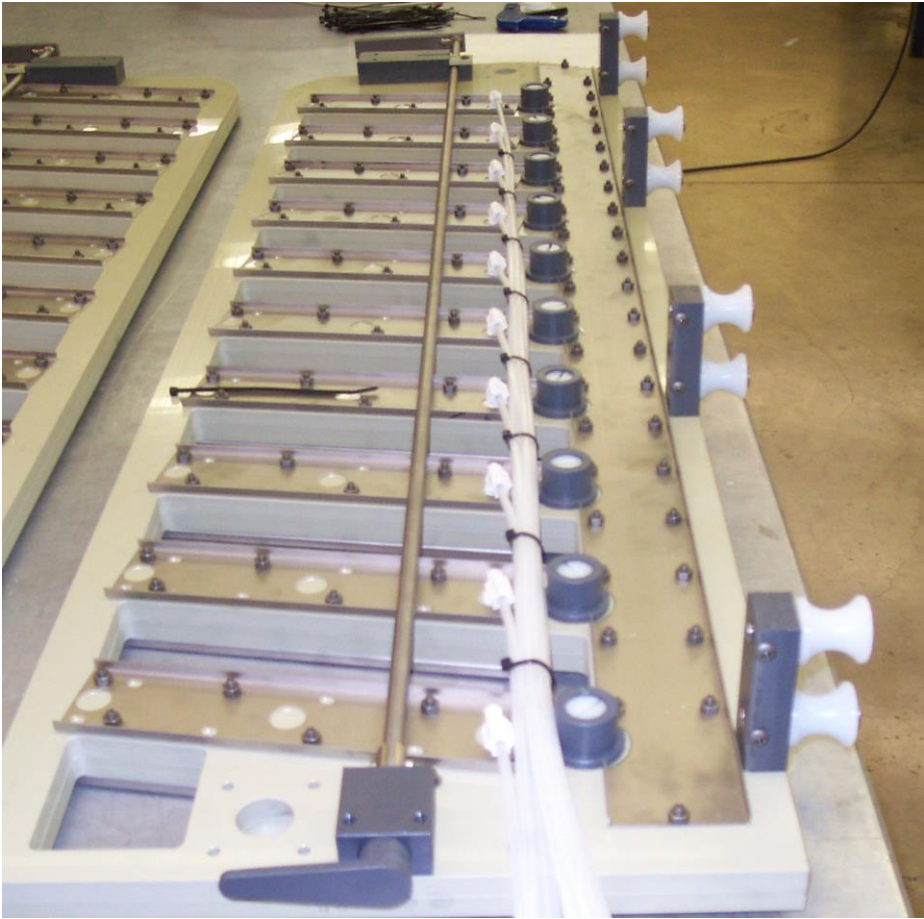

**503151      SPRAYRACK ASSY,UP/RIGHT,POS607**

ITEM_#_ON	DRAWING	PART_NUMBER	DESCRIPTION	QUANTITY
1		503152	PLATE,TOP,UPPER RACK,RHT,30 NZ	1.
2		503153	PLATE,BOT,UPPER RACK,RHT,30 NZ	1.
0		700404	SEAL,O-RING,EPDM,1/8 X RANDOM	50.000
9		501073	ROLLER GUIDE,SPRAY RACK	8.
10		502552	PIN,ROLLER,SPRAYRACK	8.
11		002710	SCREW,RD,TI,1/4-20 X 1"	10.
12		503128	BLOCK,ROLLER MTG,OFFSET,POS607	4.
13		003029	SCREW,RD,TI,1/4-20 X 1-1/4"	10.
17		503167	BRACE,SPRAYRACK,UPR RHT,65.25"	1.
19		503134	BRACE,SPRAYRACK,TI,65.250"	1.
23		503168	BRACE,SPRAYRACK,TI,11.875"	20.
25		009356	BOLT,HEX,TI,1/4-20X1-3/4	104.
26		003032	NUT,HEX,TI,1/4-20	104.
28		501098	ADAPTER,ADJUST PLUG,1-14 UNF	10.
31		501097	PLUG,ADJUSTING,PPL,1-14 UNF	10.
37		145556	SCREW,FLAT,TI,10-24 X 3/4"	2.
39		503139	CAM LOCK INSTL,POS60*	1.
41		142534	PIN,GRAPHITE,1/4ODX3/4LG	2.
42		003056	WASHER,FLAT,TI,1/4 NOM	6.

9.4.9 SPRAYRACK ASSY,LOW/RHGT,POS607



**503169      SPRAYRACK ASSY,LOW/RHGT,POS607**

ITEM_#_ON	DRAWING	PART_NUMBER	DESCRIPTION	QUANTITY
1		503170	PLATE,TOP,LOWER RACK,RHT,30 NZ	1.
2		503171	PLATE,BOT,LOWER RACK,RHT,30 NZ	1.
0		700404	SEAL,O-RING,EPDM,1/8 X RANDOM	50.000
9		501073	ROLLER GUIDE,SPRAY RACK	8.
10		502552	PIN,ROLLER,SPRAYRACK	8.
11		002710	SCREW,RD,TI,1/4-20 X 1"	10.
12		503150	BLOCK,ROLLER MTG,SPRAYRACK,LWR	4.
13		003029	SCREW,RD,TI,1/4-20 X 1-1/4"	10.
17		503172	BRACE,SPRAYRACK,LWR RHT,65.25"	1.
19		503134	BRACE,SPRAYRACK,TI,65.250"	1.
23		503168	BRACE,SPRAYRACK,TI,11.875"	20.
25		009356	BOLT,HEX,TI,1/4-20X1-3/4	104.
26		003032	NUT,HEX,TI,1/4-20	104.
28		501098	ADAPTER,ADJUST PLUG,1-14 UNF	10.
31		501097	PLUG,ADJUSTING,PPL,1-14 UNF	10.
37		145556	SCREW,FLAT,TI,10-24 X 3/4"	2.
39		503139	CAM LOCK INSTL,POS60*	1.
41		142534	PIN,GRAPHITE,1/4ODX3/4LG	2.
42		003056	WASHER,FLAT,TI,1/4 NOM	6.

### 9.4.10 CNVR,ROLL,POS607,LR,N/OUT ROLL

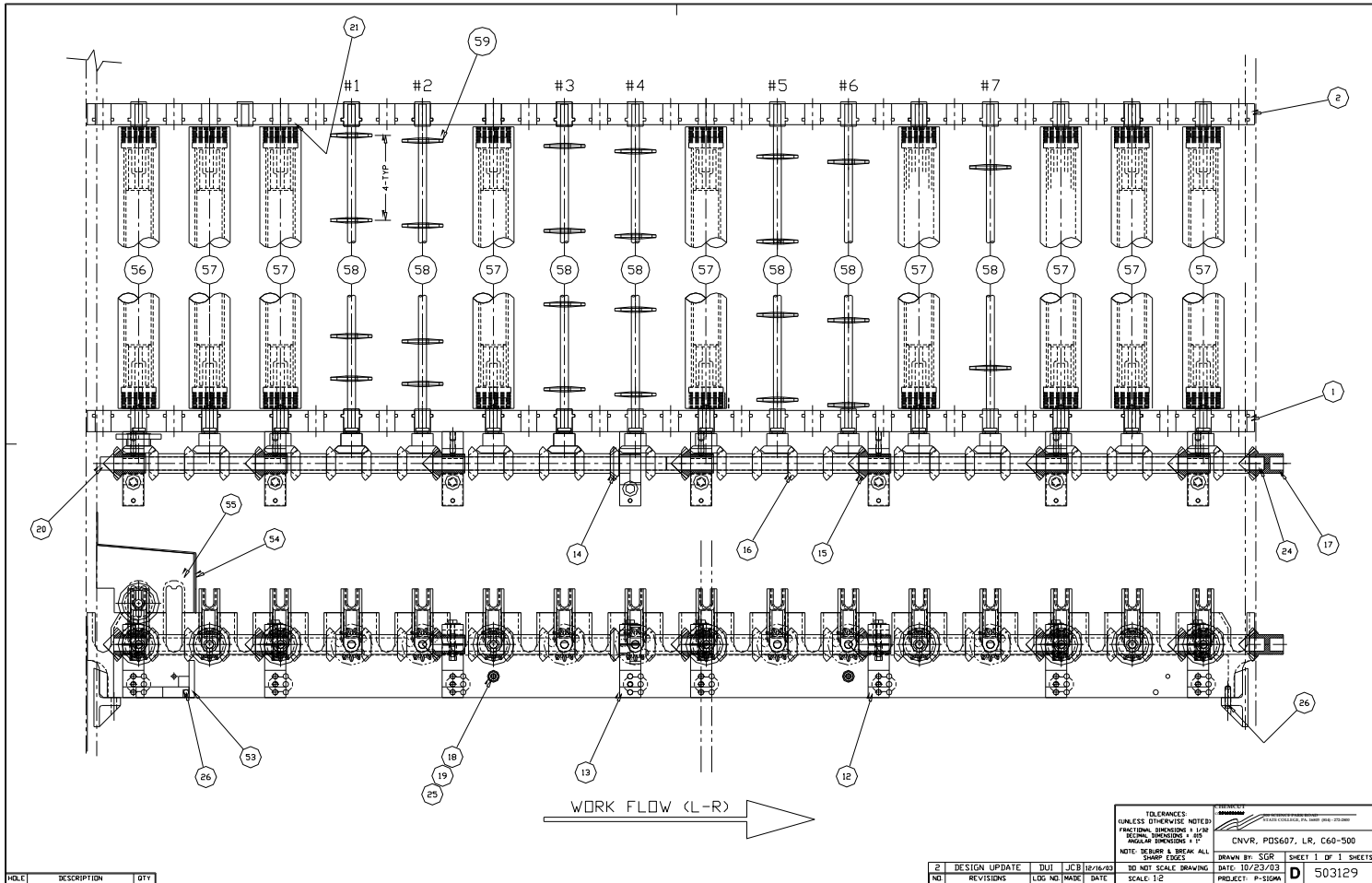



**503129 CNVR,ROLL,POS607,LR,N/OUT ROLL**

ITEM_#_ON	DRAWING	PART_NUMBER	DESCRIPTION	QUANTITY
1		500995	SIDERAIL,FRONT,33 ROD,POS07	1.
2		500996	SIDERAIL,REAR,33 ROD,POS07	1.
12		500932	STRUT,P-SIGMA,STD,TI *	7.
13		500933	STRUT,P-SIGMA,L-R,TI	1.
14		501024	GEAR,MITER,13T,PVDF,.929,9P *	1.
15		501025	GEAR,MITER,13T,PVDF,1.500,9P *	7.
16		501026	GEAR,MITER,13T,PVDF,1.662,9P	24.
17		501027	GEAR,MITER,13T,BLIND,PVDF,9P *	1.
18		503259	ROD,TIE,CNVR,TI,60	2.
19		003032	NUT,HEX,TI,1/4-20	8.
20		501358	SHAFT,LINE,TI,26.576	1.
21		501107	BRACE,SIDERAIL,POS07	2.
24		501359	SHAFT,LINE,TI,28.057	1.
25		003056	WASHER,FLAT,TI,1/4 NOM	4.
26		023353	PIN,GRAPHITE,1/4ODX1LG	4.
53		604176	BAFFLE,LWR,60,1-ROLL,PVC,EXT	1.
54		604177	BAFFLE,UPPER,TI,60,POS607	1.
55		502467	END PLATE,BAFFLE,POS	2.
56		503123	ROLL,60,2X2,SOLID,TPN/TI*	1.
57		503130	ROLL,60,2X2,SOLID,LWR,TPN/TI	8.
58		503281	ROD,60,2X2,LWR ONLY,GRAPHITE	7.
59		106950	WHEEL,CNVR,TPN45D,2SX3/8,5HOLE	108.



9.4.11 ROLL,60,2X2,SOLID,TPN/TI\*

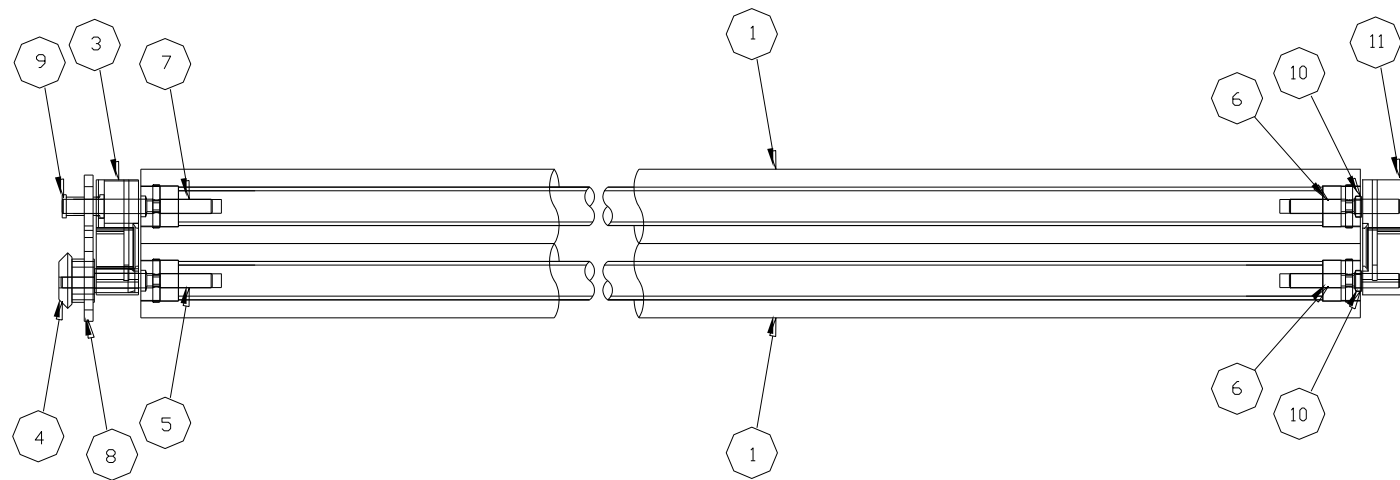

ROLL, 60, 2X2, SOLID, TPN/TI  
503123

**503123      ROLL,60,2X2,SOLID,TPN/TI\***

ITEM_#_ON	DRAWING	PART_NUMBER	DESCRIPTION	QUANTITY
1		501536	ROLL,D,61-3/4X1.9,TPN	2.
3		501015	INSERT,SRAIL,SLTD1-15/16,PVDF*	1.
4		501019	GEAR,MITER,SPUR,13T,PVDF .920*	1.
5		149401	SHAFT,PIN,TI,3/8X3-15/16LG *	1.
6		149399	SHAFT,PIN,TI,3/8X2-7/8LG *	2.
7		137116	SHAFT ASSY,1PIN/SK,TI *	1.
8		501020	GEAR,SPUR,15T,EXT,PVDF *	1.
9		501041	GEAR,SPUR,15T,TABBED,PVDF *	1.
10		141546	CLIP,RETAINER,PPL	2.
11		501016	INSERT,SRAIL,BLIND1-15/16PVDF*	1.

9.4.12 ROLL,60,2X2,SOLID,LWR,TPN/T

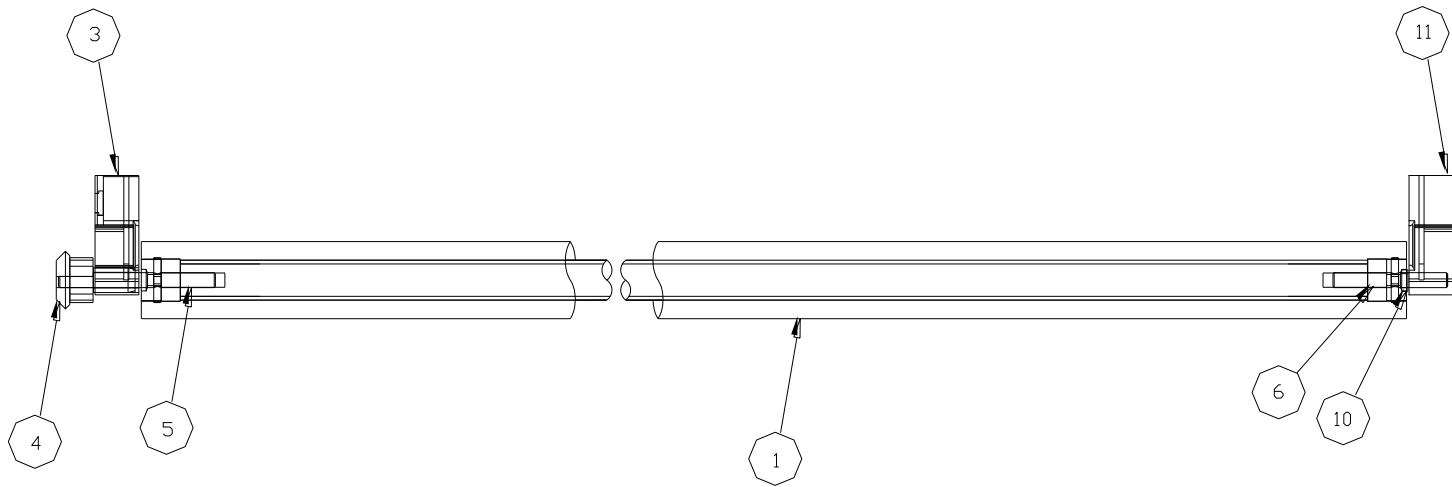

ROLL, 60, 2X2, SOLID, LWR  
503130

**503130      ROLL,60,2X2,SOLID,LWR,TPN/T**

|

ITEM\_#\_ON

DRAWING	PART_NUMBER	DESCRIPTION	QUANTITY
1	501536	ROLL,D,61-3/4X1.9,TPN	1.
3	501015	INSERT,SRAIL,SLTD1-15/16,PVDF*	1.
4	501019	GEAR,MITER,SPUR,13T,PVDF .920*	1.
5	149401	SHAFT,PIN,TI,3/8X3-15/16LG *	1.
6	149399	SHAFT,PIN,TI,3/8X2-7/8LG *	1.
10	141546	CLIP,RETAINER,PPL	1.
11	501016	INSERT,SRAIL,BLIND1-15/16PVDF*	1.

### 9.4.13 ROD,60,2X2,LWR ONLY,GRAPHITE



ROD 2X2,LWR ONLY 30 GFK

501007

**503281      ROD,60,2X2,LWR ONLY,GRAPHITE**

ITEM_#_ON	DRAWING	PART_NUMBER	DESCRIPTION	QUANTITY
0	501007	ROD,30,2X2,LWR ONLY,FBRGL	*	0.00000000
1	503282	ROD,GRAPHITE,3/8X65,D	*	1.
2	501015	INSERT,SRAIL,SLTD1-15/16,PVDF*		1.
3	501016	INSERT,SRAIL,BLIND1-15/16PVDF*		1.
4	501019	GEAR,MITER,SPUR,13T,PVDF .920*		1.

#### 9.4.14 PLUMBING,POS607

#### 503105 PLUMBING,POS607

ITEM_#_ON			
DRAWING	PART_NUMBER	DESCRIPTION	QUANTITY
1	503146	PLUMBING,POS607,LOWER RACK	1.
2	503165	PLUMBING,POS607,UPPER RACK	1.
3	503166	PLUMBING,POS607,DRAIN	1.

### 9.4.15 PLUMBING, POS607, LOWER RACK

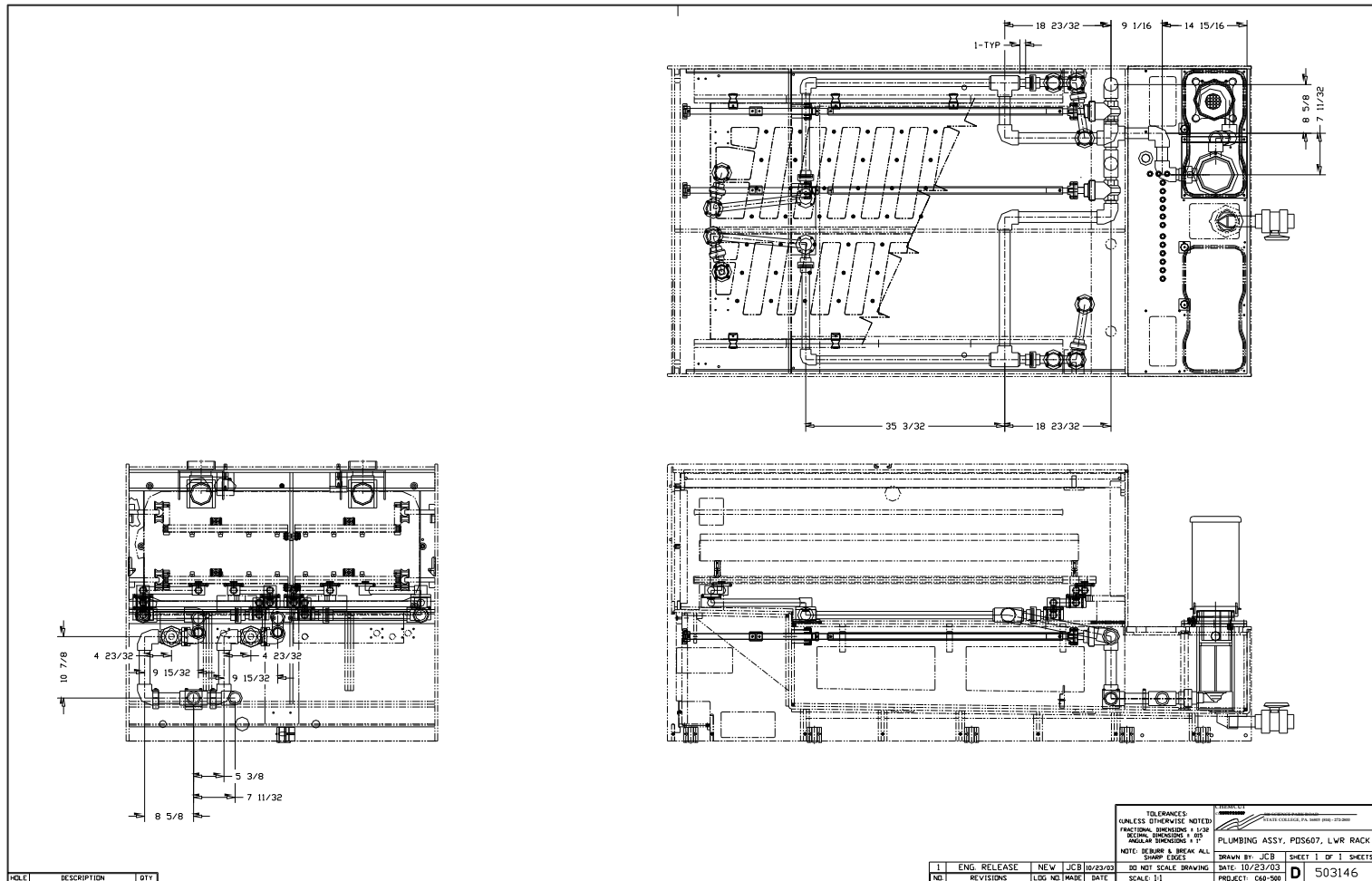



**503146 PLUMBING,POS607,LOWER RACK**

ITEM_#_ON	DRAWING	PART_NUMBER	DESCRIPTION	QUANTITY
1	501045		FILTER/CARAPACE,POS***,PVC	1.
2	002401		ELBOW,90,PVC,1-1/2SOC,SCH80 S	10.
3	025781		TEE,PVC,1-1/2SOC,SCH80 S	3.
4	143841		VALVE,GATE,PVC,1-1/2SOC S	2.
5	153955		BUSHING,PVC,1-1/2MSX1FS S	4.
6	151193		CLAMP,TRIM-FIT,1",PVC/TI	4.
7	002133		PIPE,PVC,1-1/2IN,SCH80 S	12.000
8	153684		CLAMP,TRIM-FIT,1-1/2,PVC/TI	2.
9	503144		HANDLE INSTL,POS60	2.
10	147259		CLAMP,PVC/TI,1-1/2,SCH80 FIT	3.
11	003023		BOLT,HEX,TI,1/4-20X1-1/2	4.
12	003024		BOLT,HEX,TI,1/4-20X1	4.
13	069565		PVC,1/2 X 1/2	24.000
14	002155		PIPE,PVC,1IN,SCH80 S	10.000
15	503157		HOSE ASSY,MECHANICAL,PVC,POS60	4.
16	002710		SCREW,RD,TI,1/4-20 X 1"	8.

# 9.4.16 PLUMBING, POS607, UPPER RACK

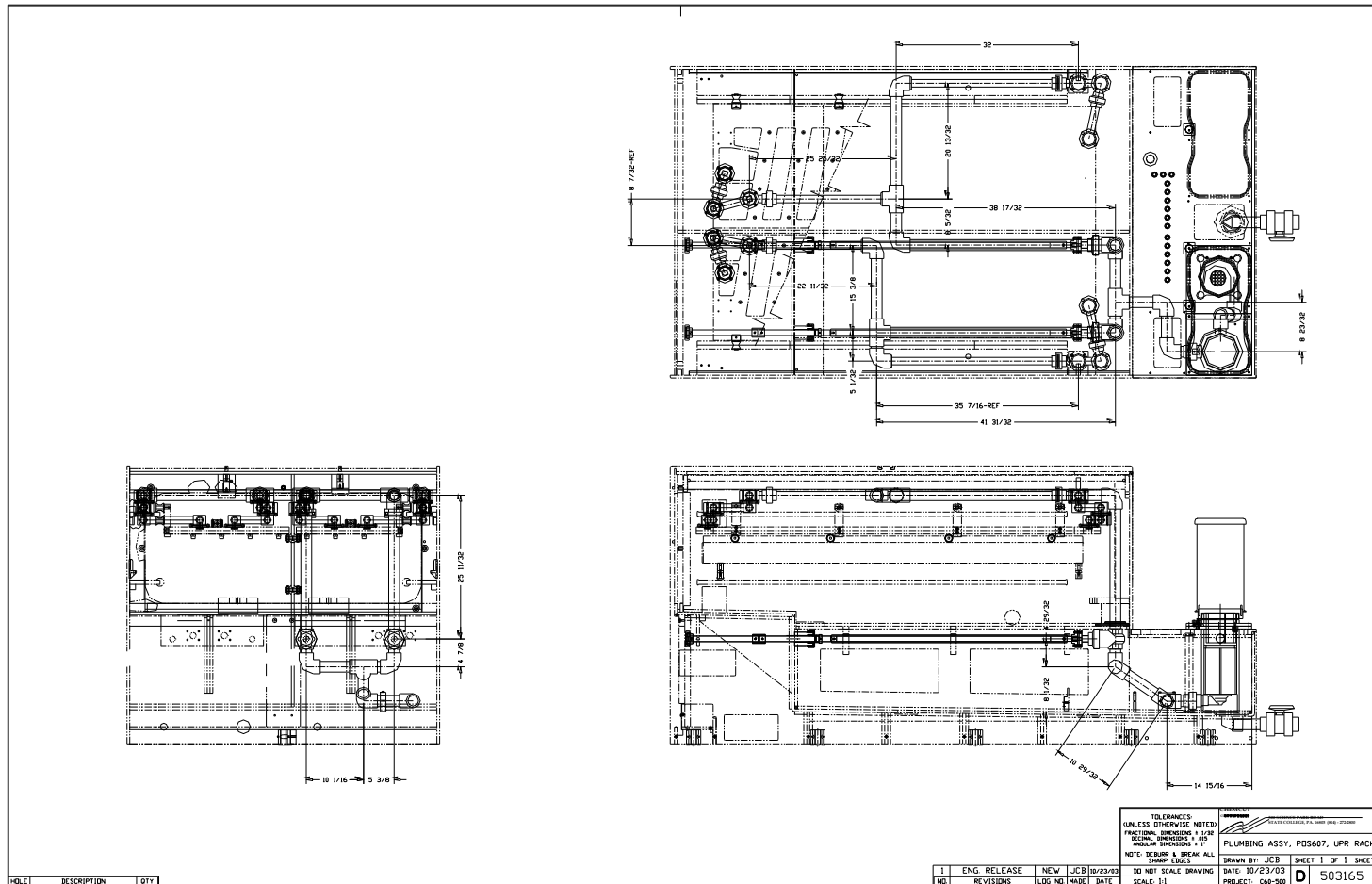

**503165 PLUMBING,POS607,UPPER RACK**

ITEM_#_ON	DRAWING	PART_NUMBER	DESCRIPTION	QUANTITY
1	501045		FILTER/CARAPACE,POS***,PVC	1.
2	002401		ELBOW,90,PVC,1-1/2SOC,SCH80 S	10.
3	025781		TEE,PVC,1-1/2SOC,SCH80 S	3.
4	143841		VALVE,GATE,PVC,1-1/2SOC S	2.
5	153955		BUSHING,PVC,1-1/2MSX1FS S	4.
6	151193		CLAMP,TRIM-FIT,1",PVC/TI	4.
7	002133		PIPE,PVC,1-1/2IN,SCH80 S	12.000
8	153684		CLAMP,TRIM-FIT,1-1/2,PVC/TI	2.
9	503144		HANDLE INSTL,POS60	2.
10	147259		CLAMP,PVC/TI,1-1/2,SCH80 FIT	3.
11	003023		BOLT,HEX,TI,1/4-20X1-1/2	4.
12	003024		BOLT,HEX,TI,1/4-20X1	4.
13	069565		PVC,1/2 X 1/2	24.000
14	002155		PIPE,PVC,1IN,SCH80 S	10.000
15	503157		HOSE ASSY,MECHANICAL,PVC,POS60	4.
16	002710		SCREW,RD,TI,1/4-20 X 1"	8.
17	145520		SUPPORT,PLUMB,1-1/2,OS	2.

**9.4.17 PLUMBING,POS607,DRAIN**

**503166 PLUMBING,POS607,DRAIN**

ITEM_#_ON				
DRAWING	PART_NUMBER	DESCRIPTION		QUANTITY
1	018454	VALVE,BALL,PVC,1-1/2NPT,TU V S		1.
0	106242	NIPPLE,PVC,1-1/2"(TXS)5"LG		1.



**138498 PUMP SUBASSY,P-55J-C1**

ITEM_#_ON	DRAWING	PART_NUMBER	DESCRIPTION	QUANTITY
0		145430	PUMP SUBASSEMBLY(REF.DWG)	0.0
0		147234	SPECIFICATION,PUMPS,CHEMCUT	0.0
1		025261	MOTOR,AC,7-1/2HP(60HZ)5HP(50HZ)	1.
2		080073	COWL,MOTOR,LARGE,3,5,7-1/2 HP	1.
3		037989	SCREW,SELF TAP,10-32X3/4	1.
4		084594	COVER,HOLE,BLACK,1 INCH	1.
5		133714	MOUNT,MOTOR,RPP,P-25	1.
6		043122	BOLT,HEX,SST316,1/2-13X1-1/4	4.
7		040328	WASHER,FLAT,TI,1/2"NOM	4.
8		043089	WASHER,LOCK,SST316,1/2"NOM	4.
9		163463	SHAFT,PUMP,TI,1-1/2DIA X7/8-14*	1.
11		105644	COLUMN ASSY,PUMP,PPL (SH)	1.
12		105492	SLEEVE,PUMP COLUMN,TFE,P-24/25	1.
13		031925	SEAL,O-RING,2-225,EPDM,BLACK	1.
14		145908	PLATE,PUMP,OS,0DEG,1-1/2"	1.
15		075961	KEY,"L",TI,1/4X1/4X1"LG	1.
16		104608	COLLAR,SHAFT,SST303,1-1/2ID	1.
17		029171	COLLAR,MODIFIED	1.
18		170012	SEAL,O-RING,2-365,EPDM,BLACK	1.
19		126509	IMPELLER,TI,7/8-14,5.75X5.75,T	1.
20		135380	BOLT,HEX,TI,1/4-20X 3/4	1.
21		015811	WASHER,FLAT,TI,9/32IDX1-1/4OD	1.
22		149058	SEAL,O-RING,2-360,EPDM,BLACK	1.
23		003069	LABEL,MYLAR,(PUMP)	1.
24		014133	LABEL,WARNING,(PUMP ROTATION)	1.
25		015392	LABEL,IDENT,(ROTATION,R-L)	1.
26		145721	LABEL,"CAUTION HOT"	1.

## 9.4.19 Pump Specifications

<b>B</b>	147234							
<h3>Pump Specifications</h3>								
<p><u>CHEMCUT Pumps</u></p> <p>P/N 043122    1/2" stainless bolts into mount P/N 133714 on P/N 159000, 025261 motors 210 IP.  P/N 003785    3/8" stainless bolts into mount P/N 105642 on P/N 018336, 018277, 005088, 079177 motors 165 IP.  All shaft collar bolts 150 IP.  P/N 015809    1/4-20 Ti bolt for all impellers 90 IP.  P/N 041760    3/8" Ti bolts into P/N 046276 columns 160 IP  P/N 003032    1/4-20 Ti nuts on all pump housings 45 IP.  P/N 041760    3/8" Ti bolts into P/N 041741 mount to P/N 141017 column 160 IP.  P/N 023736    3/8" Ti bolts into P/N 040736 column 160 IP.  P/N 040327    1/2" Ti bolts into P/N 046420, 040325 column 200 IP.  P/N 089736    1/2" Ti bolts into P/N 084577, etc. (large carapace) 125 IP.  P/N 003645    3/8" Ti bolts into P/N 110607, etc. (small carapace) 100 IP.</p>								
<p><u>Finish Thompson Pumps</u></p> <p>KC-6, 8, 10  1/4-20 SST Setscrews 65 IP  3/8" SST bolt into motor 130 IP  Phillips head screws in housing 30 IP.  KC-11  3/8" SST setscrew 200 IP  3/8" socket head bolts into motor face 130 IP  Phillips head screws in housing 30 IP</p>								
					TOLERANCES: (CUNLESS OTHERWISE NOTED) FRACTIONAL DIMENSIONS ± 1/32 DECIMAL DIMENSIONS ± .015 ANGULAR DIMENSIONS ± 1°			
					NOTE: DEBURR & BREAK ALL SHARP EDGES	DRAWN BY: KV DATE: 3.14.01	PROJECT: PUMPS SHEET 1 OF 1 SHEETS	
					DO NOT SCALE DRAWING SCALE: X	APPV'D BY: <b>B</b>		
					3 NO.	CLEANUP REVISIONS	DUI LOG NO.	
					KV MADE	6/18/01 DATE	147234	
HOLE	DESCRIPTION	QTY	NO.	REVISIONS	LOG NO.	APP'D	MADE	DATE

**9.4.20 COOLING,POS607**





COOLING,POS607





**503099 COOLING,POS607**

ITEM_#_ON	DRAWING	PART_NUMBER	DESCRIPTION	QUANTITY
1	176034	COIL,COOLING,TI,DPEM		1.
2	141853	GASKET,COOLING COIL,1.5 X 2		2.
3	003056	WASHER,FLAT,TI,1/4 NOM		8.
4	003032	NUT,HEX,TI,1/4-20		8.
5	014819	CLAMP,COIL,PVC,3/4IN		3.
6	023837	UNION,PVC,3/4NPT,SCH80,EPDM S		1.
7	028992	ELBOW,90,PVC,3/4SOC,SCH80 S		1.
8	011905	VALVE,SOL,PAINT,BRS,3/4NPT,N/C		1.
9	002165	PIPE,PVC,3/4IN,SCH80 S		7.750
10	150674	CLAMP,TRIM-FIT,3/4",PVC		1.
11	141381	COOLING COIL,DRAIN SUPPORT		1.
12	069565	PVC,1/2 X 1/2		2.500
13	002380	ELBOW,90,PVC,3/4NPT,SCH80 S		1.
14	080302	UNION,PVC,3/4SOC,SCH80,VITON S		2.
15	080063	ELBOW,45,PVC,3/4SOC,SCH40		2.

**9.4.21 GAUGE INSTL, POS607,0-60 (40)**

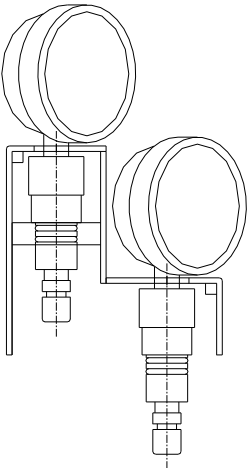
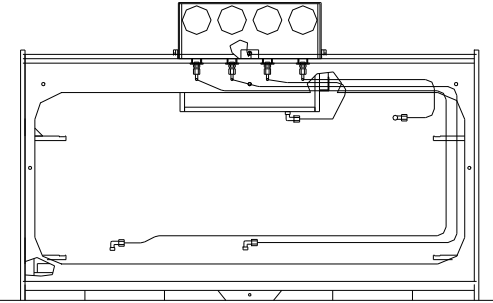
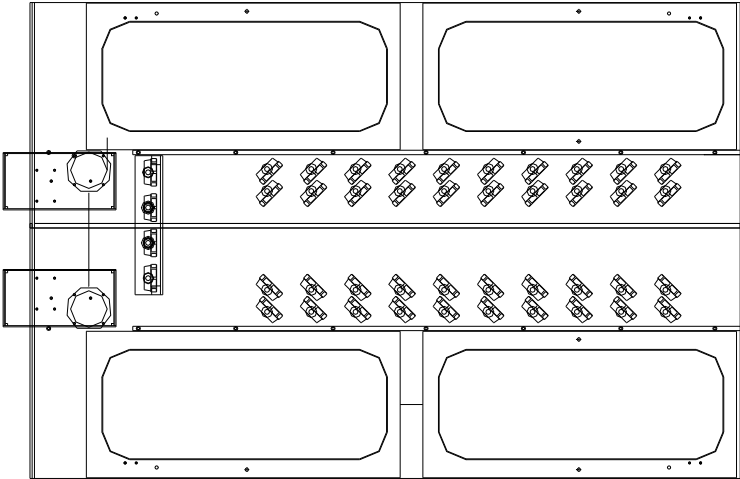

**503113 GAUGE INSTL,POS607,0-60 (40)**

ITEM_#_ON	DRAWING	PART_NUMBER	DESCRIPTION	QUANTITY
0		103650	GAUGE,PRESS,0-60/4BAR,W/ISOL	40.
0		003833	CONNECTOR,MALE,PP,1/4TX1/4NPT	40.
0		017905	INSERT,PP,1/4OD TUBE	80.
0		011974	TUBING,PE,1/4"ODX.040 W	450.000
0		016108	ELBOW,MALE,PP,1/4TX1/4NPT	40.
0		137355	SHEET,PVC,EUROGRY,1/2X51X122IN	8.000
0		137353	SHEET,PVC,EUROGRY,1/8X48X96IN	8.000
0		002712	SCREW,RD,TI,1/4-20 X 1/2	40.
0		025980	RETAINER,TUBE,PVC,MOLDED	120.
14		501791	INSERT,MALE,1/8"ID,PPL	40.
15		501792	INSERT,FEMALE,1/8"ID,PPL	40.
0		144178	THUMBSCREW,TI,1/4-20X1-1/2,CAP	8.
0		023353	PIN,GRAPHITE,1/4ODX1LG	16.
0		133930	INSERT,THD,TI,1/4-20X.472	8.
0		002709	SCREW,RD,TI,1/4-20 X 1-1/2"	16.
21		503216	COVER ASSY,20 PRESSURE GAUGE	2.
22		503218	COUPLING ASSY,10 HOSE	4.
23		012803	GASKET,RD,TY,7/32"IDX1"ODX1/4	20.

## 9.4.22 GAUGE INSTL,PRESS,PEM,(2)

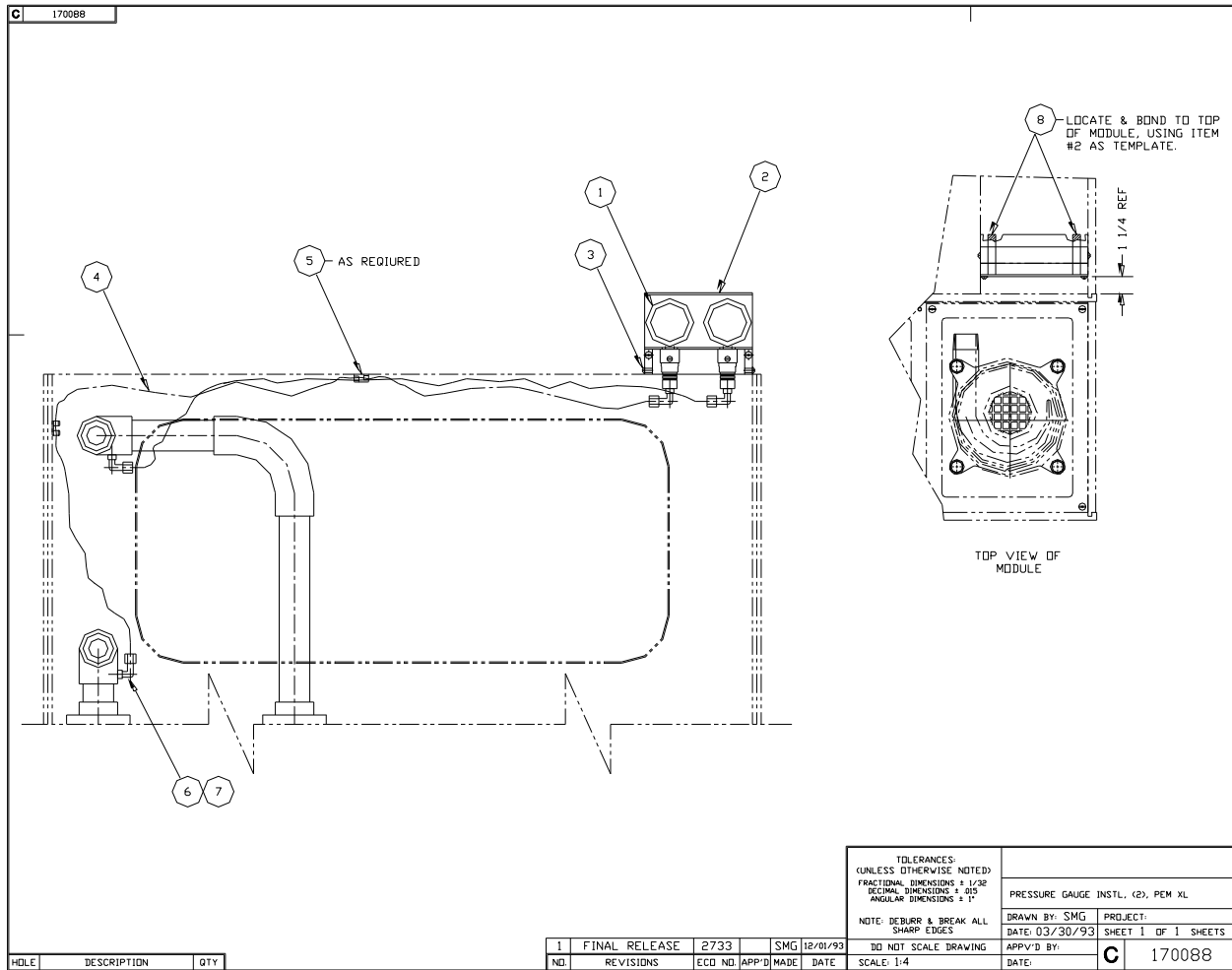

**170088 GAUGE INSTL,PRESS,PEM,(2)**

ITEM_#_ON	DRAWING	PART_NUMBER	DESCRIPTION	QUANTITY
1		103650	GAUGE,PRESS,0-60/4BAR,W/ISOL	2.000
2		170404	COVER ASSY,PG,PVC,(2)	1.000
3		002711	SCREW,RD,TI,1/4-20 X 3/4"	2.000
4		011974	TUBING,PE,1/4"ODX.040 W	12.000
5		025980	RETAINER,TUBE,PVC,MOLDED	2.000
6		016108	ELBOW,MALE,PP,1/4TX1/4NPT	4.000
7		017905	INSERT,PP,1/4OD TUBE	4.000
8		069565	PVC,1/2 X 1/2	2.625
8		069565	PVC,1/2 X 1/2	2.625

### 9.4.23 NOZZLE INSTL,EDGE ETCH

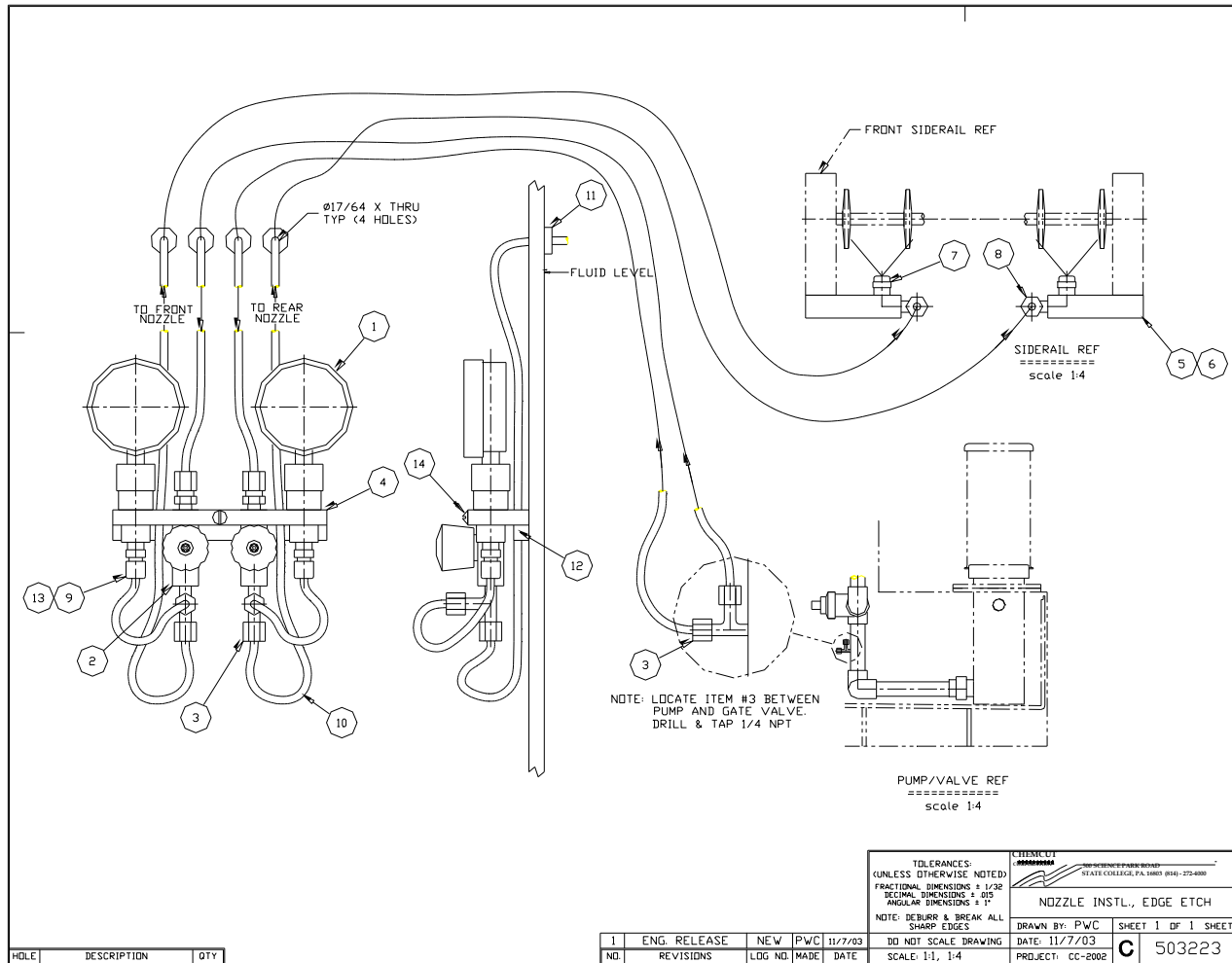



503223 NOZZLE INSTL,EDGE ETCH

ITEM_#_ON	DRAWING	PART_NUMBER	DESCRIPTION	QUANTITY
1		103650	GAUGE,PRESS,0-60/4BAR,W/ISOL	2.
2		156718	VALVE,NEEDLE,PVC,1/4NPT	2.
3		106935	TEE,MALE RUN,PPL,1/4NPTX1/4T	3.
4		503225	CLAMP,MTG,GAUGE/VALVE	1.
5		503224	BLOCK,MTG,NOZZLE	2.
6		002710	SCREW,RD,TI,1/4-20 X 1"	2.
7		149941	NOZZLE,SCRD,PVDF,.75GPM,80DEG	2.
8		016108	ELBOW,MALE,PP,1/4TX1/4NPT	2.
9		003833	CONNECTOR,MALE,PP,1/4TX1/4NPT	4.
10		011974	TUBING,PE,1/4"ODX.040 W	25.000
11		012803	GASKET,RD,TY,7/32"IDX1"ODX1/4	4.
12		069565	PVC,1/2 X 1/2	7.000
13		017905	INSERT,PP,1/4OD TUBE	12.
14		002709	SCREW,RD,TI,1/4-20 X 1-1/2"	1.

### 9.4.24 HEAT,6X6KW,440-480V,TI,M BLD

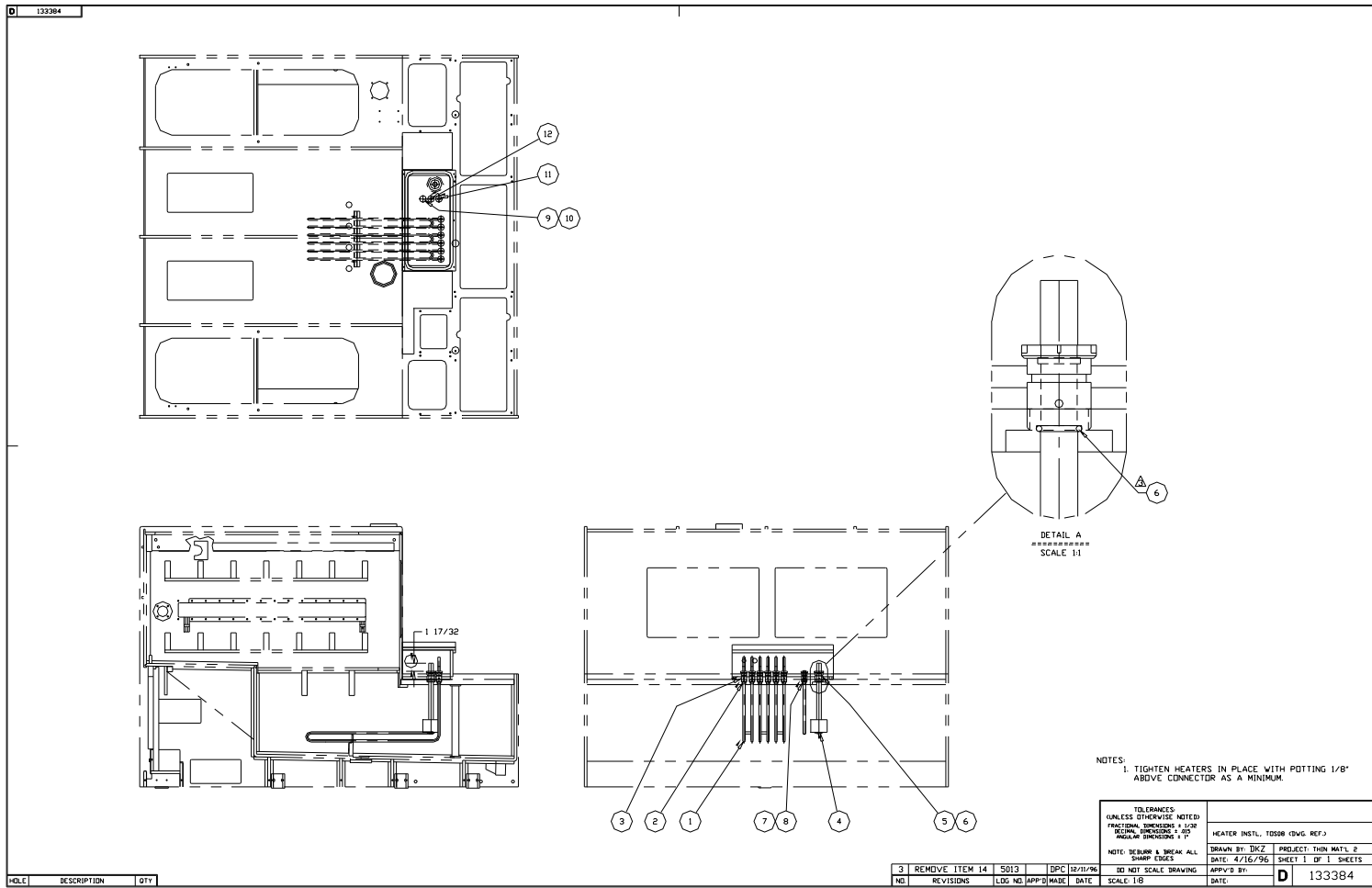

**503126 HEAT,6X6KW,440-480V,TI,M BLD**

ITEM_#_ON	DRAWING	PART_NUMBER	DESCRIPTION	QUANTITY
0		133384	HEATER INSTL,TOS08(REF DWG)	0.
1		128351	HEATER,IMM,6KW,480V,STUD,TI	6.
2		149937	INSERT,TPE,.440,CORD,MOLDED	12.
3		120526	CONNECTOR,BOX,HEATER,PP,1/2	12.
4		161614	SWITCH,LIQUID LEVEL ACTUATOR	1.
5		117113	CONNECTOR ASSY,BOX,PP,1/2PIPE	1.
6		149368	SEAL,O-RING,2-211,EPDM	1.
7		117111	CONNECTOR,BOX,PROBE,PP,1/2	2.
8		046328	INSERT,TPE,1/2,CORD,MOLDED	2.
9		117126	CONNECTOR,BOX,BLANK,PP	2.
10		046330	INSERT,TPE,7/32,CORD,MOLDED	2.
0		164422	PROBE,T-S/OT,132 F,14 IN,POLY	1.000
13		133651	BOOT,HEATER TERMINAL COVER	12.



**501676      JCT BOX INSTL,AIRGAP,POS06**

ITEM\_#\_ON

DRAWING	PART_NUMBER	DESCRIPTION	QUANTITY
0	501677	BOX ASSY,AIRGAP,POS06/08	1.0

9.4.26 RECIRC PUMP,(2)POS,3HP,W/FEEDS

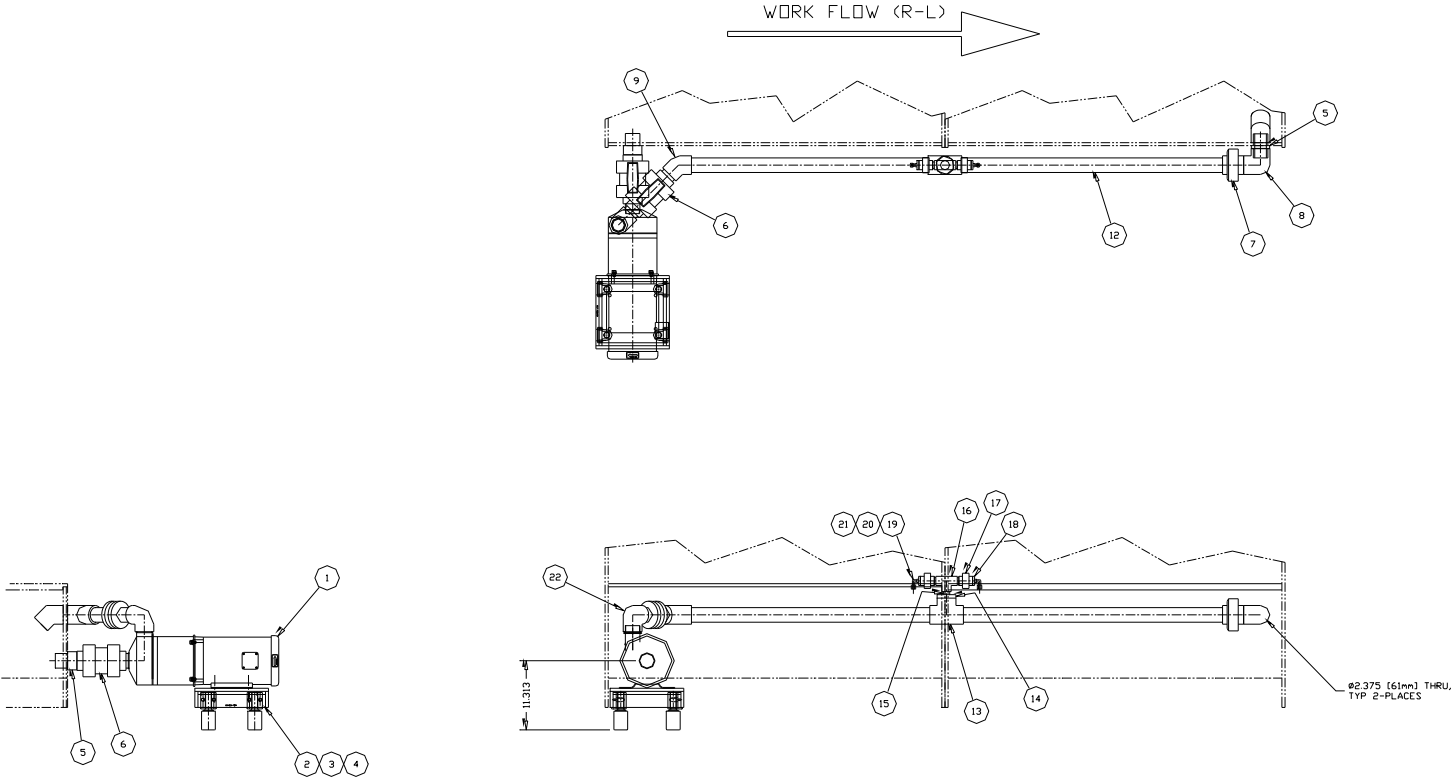

RECIRC INSTL, POS, 3-HP, W/FEEDS

502817

**502817 RECIRC PUMP,(2)POS,3HP,W/FEEDS**

ITEM_#_ON	DRAWING	PART_NUMBER	DESCRIPTION	QUANTITY
1		147075	PUMP,CENT,MD,3HPCE,KC22,NPT,RP	1.
2		135409	STAND,RECIRC,PUMP,OS,3 1/8"	1.
3		003010	BOLT,HEX,TI,3/8-16X1	4.
4		009314	WASHER,FLAT,TI,3/8"NOM	4.
5		135302	ADAPTER,PLUMBING,THRU WALL,2"	2.
6		018455	VALVE,BALL,PVC,2NPT,TU	2.
7		118537	UNION,PVC,2SOC,SCH80,EPDM	1.
8		015637	ELBOW,90,PVC,2SOC,SCH80 S	4.
9		034708	ELBOW,45,PVC,2SOC,SCH80	1.
10		153825	CLAMP,TRIM-FIT,2",PVC	2.
12		006724	PIPE,PVC,2IN,SCH80	10.000
13		025778	TEE,PVC,2SOC,SCH80	1.
14		028990	BUSHING,PVC,2MSX3/4FS	1.
15		002165	PIPE,PVC,3/4IN,SCH80 S	1.
16		028991	TEE,PVC,3/4SOC,SCH80 S	1.
17		118535	UNION,PVC,3/4SOC,SCH80,EPDM S	2.
18		142520	BUSHING,PVC,3/4MSX1/4FPT	2.
19		016108	ELBOW,MALE,PP,1/4TX1/4NPT	2.
20		017905	INSERT,PP,1/4OD TUBE	2.
21		011974	TUBING,PE,1/4"ODX.040 W	20.000
22		023949	ELBOW,90,PVC,2NPTX2SOC	1.

## 9.4.27 INTERCONNECT,SUMP,POS (4-EA)

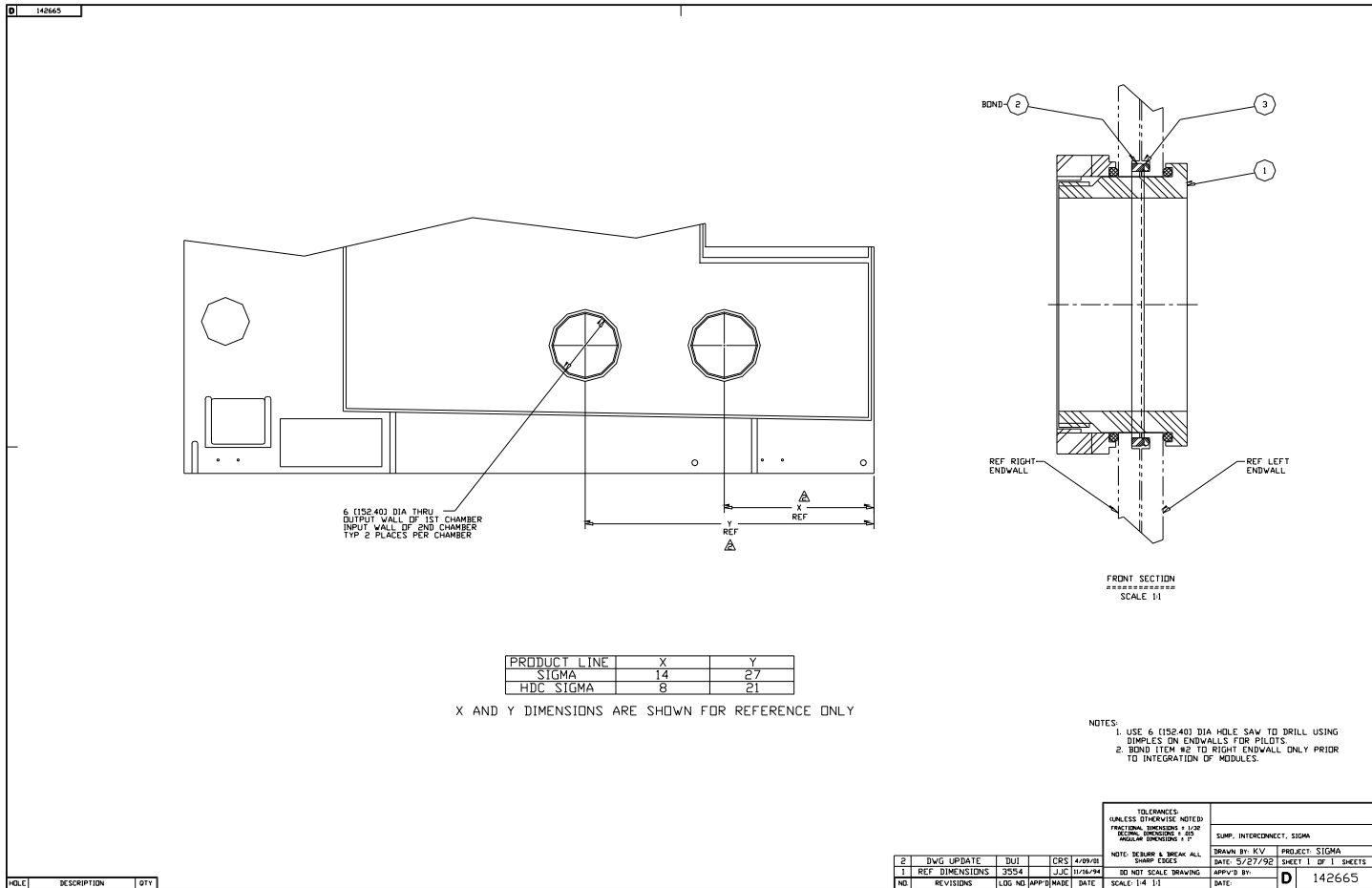



503137 INTERCONNECT,SUMP,POS (4-EA)

ITEM_#_ON	DRAWING	PART_NUMBER	DESCRIPTION	QUANTITY
0	T-2984		TOOL,WRENCH SPANNER,2 PIECES	0.
1	142665		SUMP INTERCONNECT,SIGMA,(2)	2.

142665 SUMP INTERCONNECT,SIGMA,(2)

ITEM_#_ON	DRAWING	PART_NUMBER	DESCRIPTION	QUANTITY
1	084601		ADAPTER ASSY,SUMP INTERCONNECT	2.
2	143114		RING,SUMP INTERCONNECT,OS	2.
3	022672		SEAL,O-RING,2-362,EPDM,BLACK	2.

### 9.4.28 SUPPLY,PVC SOL,1/2",POS

#### 503156 SUPPLY,PVC SOL,1/2",POS

ITEM_#_ON	DRAWING	PART_NUMBER	DESCRIPTION	QUANTITY
1		148694	COUPLING,PVC,1/2SOC,MOD	1.0
2		002176	PIPE,PVC,1/2IN,SCH80	1.0
3		118109	ELBOW,90,PVC,1/2SOC,SCH80 S	1.0
4		118534	UNION,PVC,1/2SOC,SCH80 S	1.0
5		163838	VALVE,SOL,PVC,1/2NPT,N/C,2WAY*	1.0

## 9.5 PIA634 Conveyor

### 9.5.1 PIA634M PIA634,MEC PARTS,P-SIGMA

ITEM_#_ON	DRAWING	PART_NUMBER	DESCRIPTION	QUANTITY
0	503183	CHAMBER,PIA634		1.
3	750034	COVER,SIDERAIL,REAR,PIA334		1.
4	750035	COVER,SIDERAIL,FRONT,PIA334		1.
5	503159	PLENUM,PRE634		1.
5	503188	PLENUM,PLE634		1.
6	131644	COVER INSTL,FRONT,33.882		1.
7	503158	MOD.INT.PARTS,P-SIGMA,60,TI		1.
	136186	LABELS,SIGMA,TIA,STD		1
	503127	CNVR,ROLL,PIA634,LR,C60-500		1
	503181	DRIVE,PIA634,NO-DRIVE,PAN ONLY		1
	503194	VENT INSTL,P-SIGMA,60"		1

### 9.5.2 CNVR,ROLL,PIA634,LR,C60-500

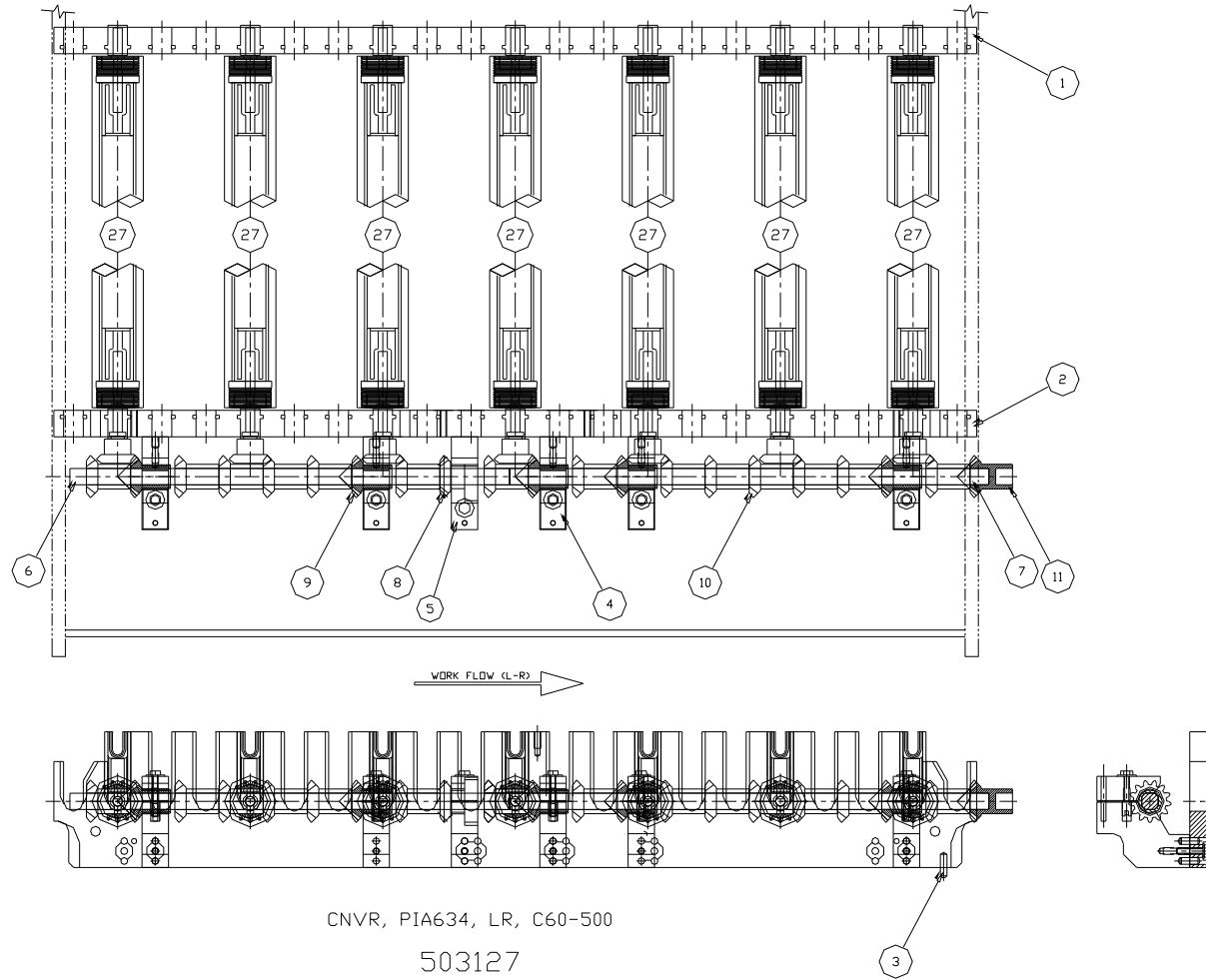

**503127 CNVR,ROLL,PIA634,LR,C60-500**

ITEM_#_ON	DRAWING	PART_NUMBER	DESCRIPTION	QUANTITY
1		501492	SIDERAIL,REAR,21 ROD,PIA34	1.
2		501493	SIDERAIL,FRONT,21 ROD,PIA34	1.
3		023353	PIN,GRAPHITE,1/4ODX1LG	2.
4		500932	STRUT,P-SIGMA,STD,TI *	5.
5		500933	STRUT,P-SIGMA,L-R,TI	1.
6		501508	SHAFT,LINE,TI,16-9/16	1.
7		502995	SHAFT,LINE,TI,18	1.
8		501024	GEAR,MITER,13T,PVDF,.929,9P *	1.
9		501025	GEAR,MITER,13T,PVDF,1.500,9P *	5.
10		501026	GEAR,MITER,13T,PVDF,1.662,9P	14.
11		501027	GEAR,MITER,13T,BLIND,PVDF,9P *	1.
27		503130	ROLL,60,2X2,SOLID,LWR,TPN/TI	7.

9.5.3 ROLL,60,2X2,SOLID,LWR,TPN/T

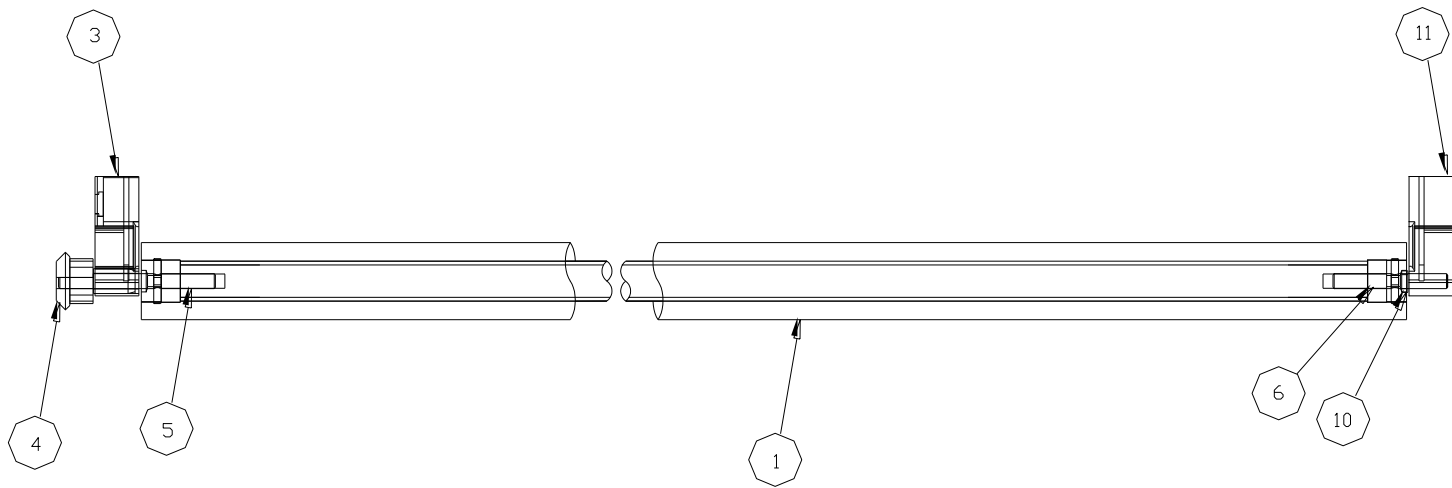

ROLL, 60, 2X2, SOLID, LWR  
503130

**503130      ROLL,60,2X2,SOLID,LWR,TPN/T**

|

ITEM\_#\_ON

DRAWING	PART_NUMBER	DESCRIPTION	QUANTITY
1	501536	ROLL,D,61-3/4X1.9,TPN	1.
3	501015	INSERT,SRAIL,SLTD1-15/16,PVDF*	1.
4	501019	GEAR,MITER,SPUR,13T,PVDF .920*	1.
5	149401	SHAFT,PIN,TI,3/8X3-15/16LG *	1.
6	149399	SHAFT,PIN,TI,3/8X2-7/8LG *	1.
10	141546	CLIP,RETAINER,PPL	1.
11	501016	INSERT,SRAIL,BLIND1-15/16PVDF*	1.

### 9.5.4 VENT INSTL,P-SIGMA,60"

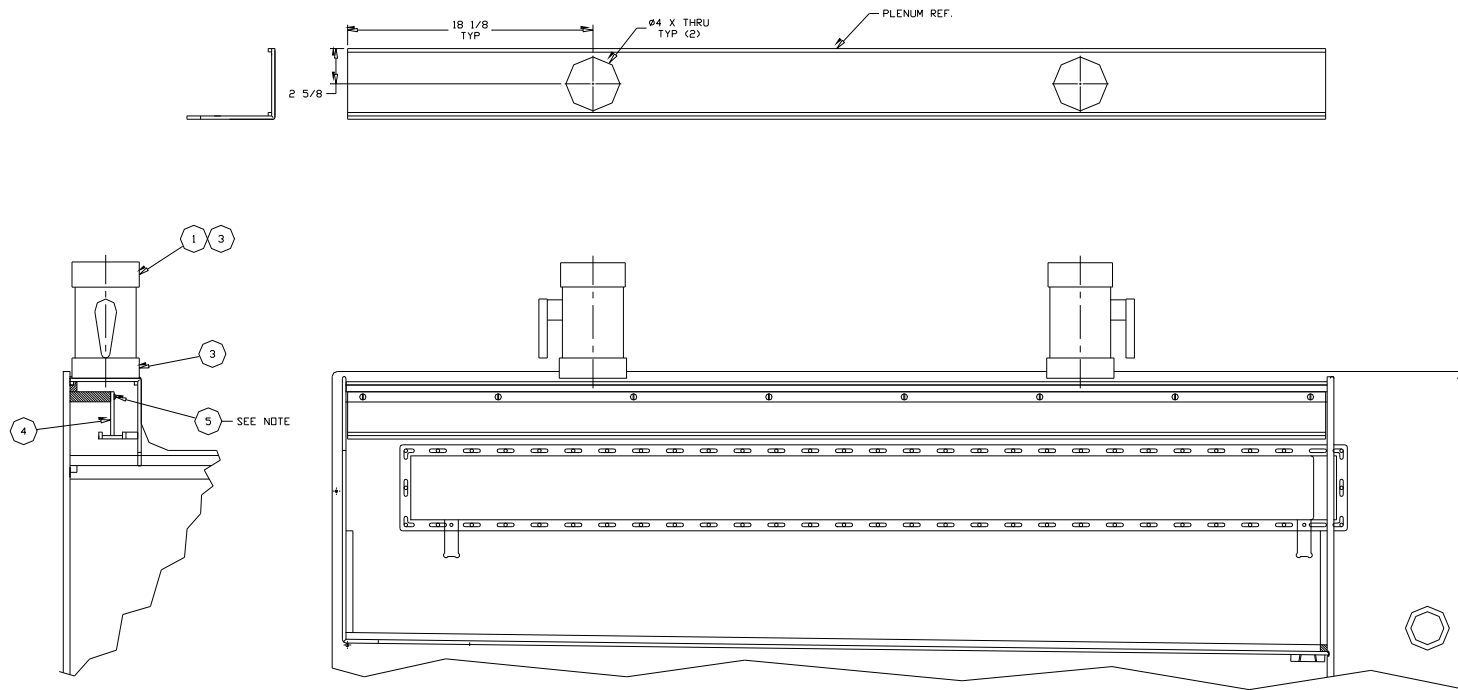

NOTE: DRILL AND TAP 1/4-20 X 13/4 DP. USING ITEM #4 AS TEMPLATE.  
TYP (Ø HOLES)

VENT INSTL., P-SIG, 60"  
503194



**503194 VENT INSTL,P-SIGMA,60"**

ITEM\_#\_ON

DRAWING	PART_NUMBER	DESCRIPTION	QUANTITY
0	503159	PLENUM,PRE634	0.00000
0	503188	PLENUM,PLE634	0.00000
1	023936	COLLAR,VENT,PVC,MOLDED,4"	2.
2	011607	DAMPER ASSY,PVC,4"ID	2.
3	049817	ADAPTER,VENT,PVC,MOLDED,4"	2.
4	503195	BAFFLE ASSY,PLENUM,60,P-SIG	1.
5	002711	SCREW,RD,TI,1/4-20 X 3/4"	8.

## 9.6 PRE634      Unload & Drive

### 9.6.1    PRE634M      PRE634,MEC PARTS,P-SIGMA

ITEM_#_ON	DRAWING	PART_NUMBER	DESCRIPTION	QUANTITY
1	503160	CHAMBER,PRE634		1.
3	502770	COVER,SIDERAIL,FRNT,PRE334		1.
7	502771	COVER,SIDERAIL,REAR,PRE334		1.
5	503159	PLENUM,PRE634		1.
6	131644	COVER INSTL,FRONT,33.882		1.
7	503158	MOD.INT.PARTS,P-SIGMA,60,TI		1.
	136187	LABELS,SIGMA,TLE\TRE,STD		1
	503131	CNVR,ROLL,PRE634,LR,C60-500		1
	503154	DRIVE,PRE634,140IPM,TI,C60-500		1
	503164	DRAIN BACK,PLE/PRE-PIA-POS,1"		1

## 9.6.2 CNVR,ROLL,PRE634,LR,C60-500

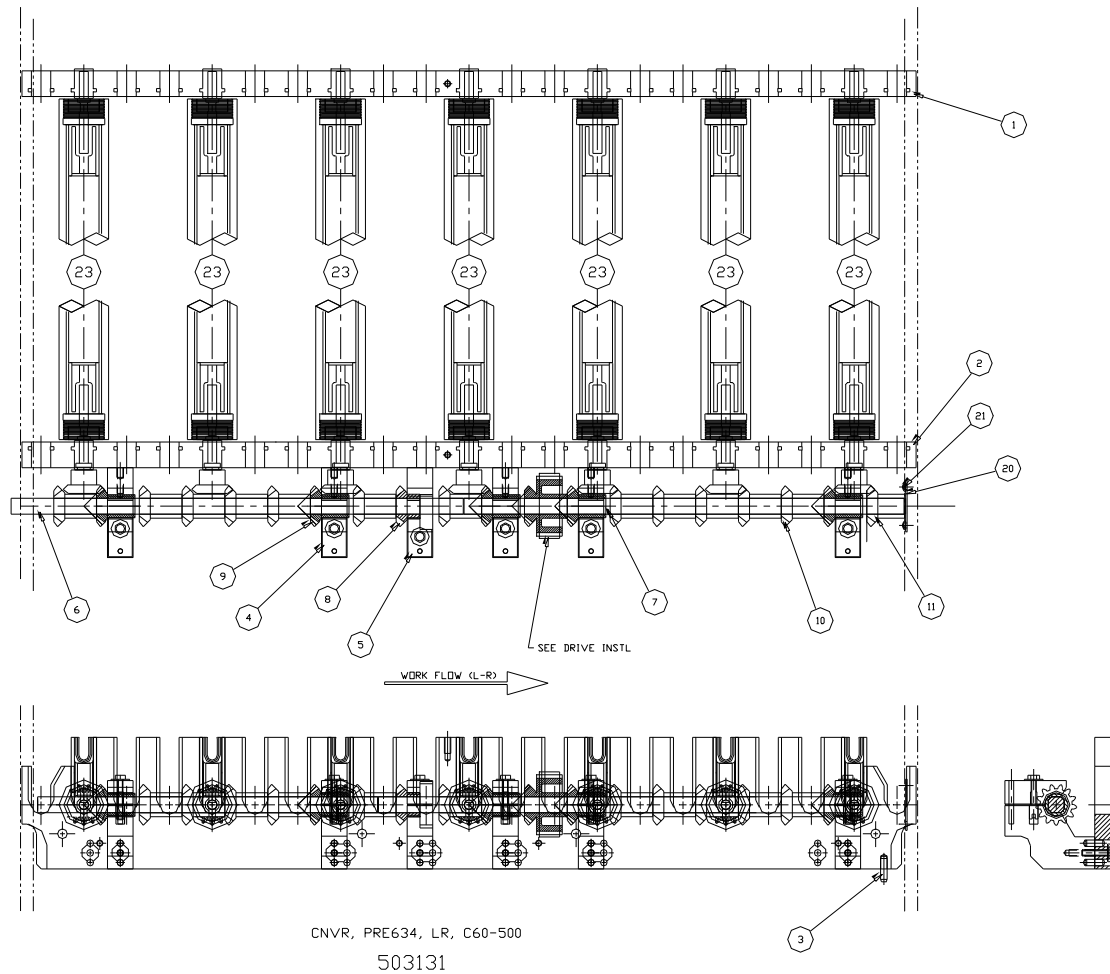

**503131 CNVR,ROLL,PRE634,LR,C60-500**

ITEM_#_ON	DRAWING	PART_NUMBER	DESCRIPTION	QUANTITY
1		501492	SIDERAIL,REAR,21 ROD,PIA34	1.
2		501493	SIDERAIL,FRONT,21 ROD,PIA34	1.
3		023353	PIN,GRAPHITE,1/4ODX1LG	2.
4		500932	STRUT,P-SIGMA,STD,TI *	5.
5		500933	STRUT,P-SIGMA,L-R,TI	1.
6		502998	SHAFT,LINE,TI,17-9/16	1.
7		502999	SHAFT,LINE,TI,17-3/16	1.
8		501024	GEAR,MITER,13T,PVDF,.929,9P *	1.
9		501025	GEAR,MITER,13T,PVDF,1.500,9P *	5.
10		501026	GEAR,MITER,13T,PVDF,1.662,9P	13.
11		501060	GEAR,MITER,13T,PVDF,1.474,9P *	1.
18		501064	GEAR,SPUR,11T,1/2ID,PVDF *	1.
20		501065	PLATE,SKID,DRIVELINE *	1.0
21		003615	SCREW,PAN,SST18-8,10-32 X 1/4"	2.0
23		503130	ROLL,60,2X2,SOLID,LWR,TPN/TI	7.

9.6.3 ROLL,60,2X2,SOLID,LWR,TPN/T

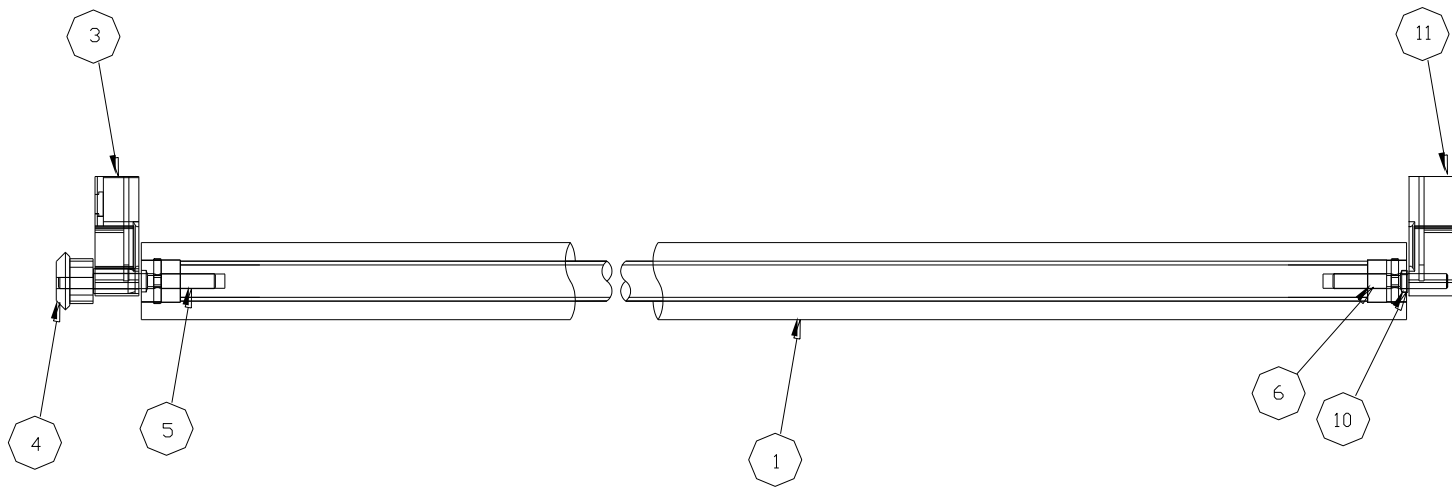

ROLL, 60, 2X2, SOLID, LWR  
503130



**503130      ROLL,60,2X2,SOLID,LWR,TPN/T**

|

ITEM\_#\_ON

DRAWING	PART_NUMBER	DESCRIPTION	QUANTITY
1	501536	ROLL,D,61-3/4X1.9,TPN	1.
3	501015	INSERT,SRAIL,SLTD1-15/16,PVDF*	1.
4	501019	GEAR,MITER,SPUR,13T,PVDF .920*	1.
5	149401	SHAFT,PIN,TI,3/8X3-15/16LG *	1.
6	149399	SHAFT,PIN,TI,3/8X2-7/8LG *	1.
10	141546	CLIP,RETAINER,PPL	1.
11	501016	INSERT,SRAIL,BLIND1-15/16PVDF*	1.

# 9.6.4 DRIVE, PRE634, 140IPM, TI, C60-500

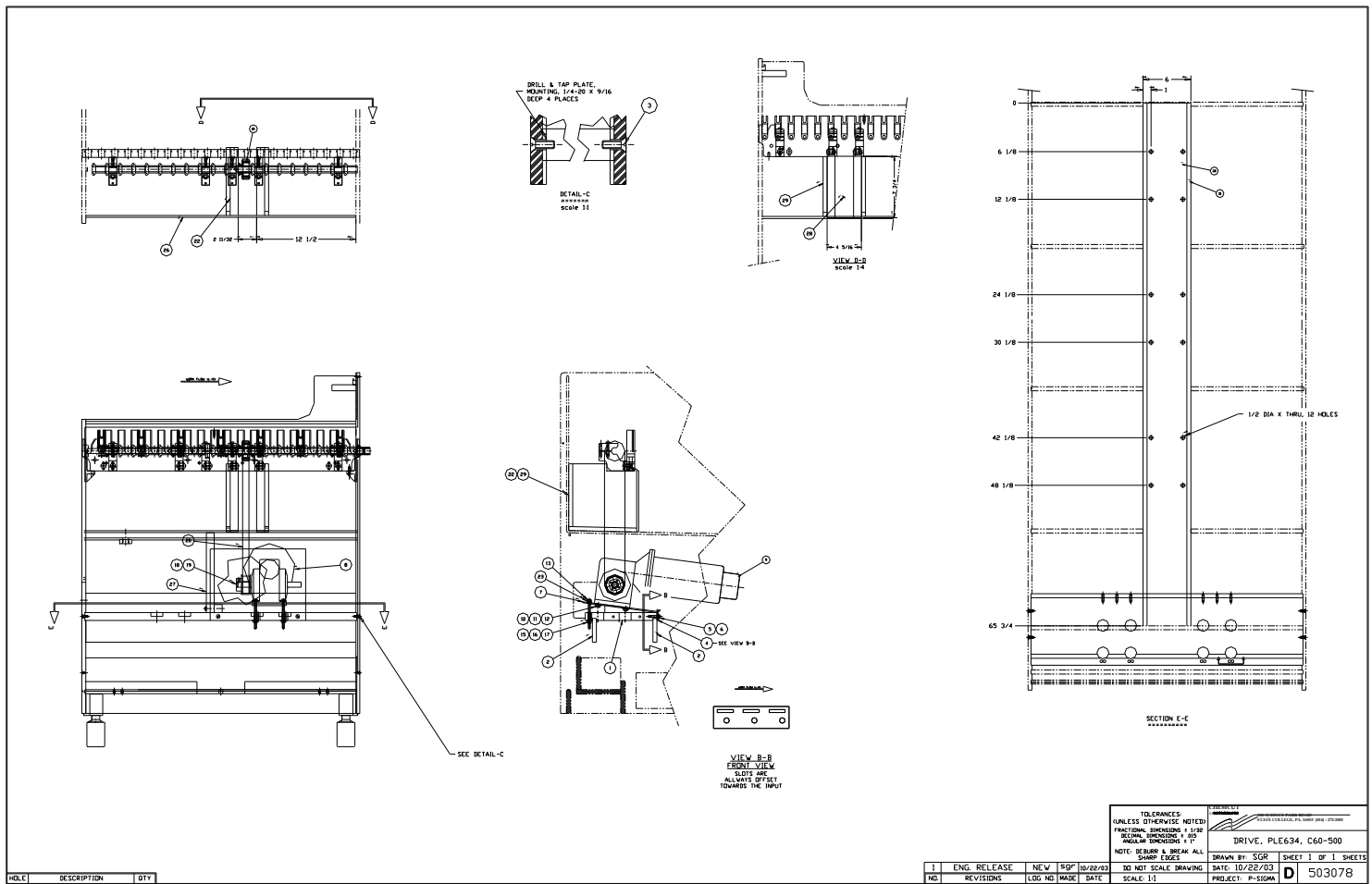



**503154 DRIVE,PRE634,140IPM,TI,C60-500**

ITEM_#_ON	DRAWING	PART_NUMBER	DESCRIPTION	QUANTITY
1		502383	MOUNT,MOTOR,DRIVE,PIA*34	1.
2		067264	PVC,1/2 X 3	34.000
2		067264	PVC,1/2 X 3	34.000
3		035566	SCREW,FLAT,SST316,1/4-20X1	4.0
4		502361	PLATE,MTG,TENSION ADJ,P-S,TI	1.
5		003019	BOLT,HEX,TI,5/16-18X3/4	3.
6		003055	WASHER,FLAT,TI,5/16"NOM	3.
7		502362	PLATE,TENSION ADJUST,P-SIG,TI	1.
8		114593	REDUCER,SPEED,60:1	1.0
9		105659	MOTOR,DC,1/4 HP,TACH-7V/K,CE *	1.0
10		003019	BOLT,HEX,TI,5/16-18X3/4	4.
11		003055	WASHER,FLAT,TI,5/16"NOM	4.
12		013155	WASHER,LOCK,SST316,5/16"NOM	4.0
13		100128	BOLT,HEX,TI,1/4-20X3	2.
15		003056	WASHER,FLAT,TI,1/4 NOM	2.
16		026866	WASHER,LOCK,SST316,1/4"NOM	2.0
17		003032	NUT,HEX,TI,1/4-20	2.
18		087396	SPROCKET,BELT,HTD,BLK,5/8ID,24	1.0
19		170135	KEY,SQ TI,3/16X3/4LG	1.
20		080853	BELT,HTD,1040-8M-20	1.0
21		501087	GEAR,DRIVE,PVDF,9P,1.662,24T	1.0
22		501085	SUPPORT,DRIVE,SIDERAIL,P-SIGMA	2.0
23		501229	WASHER,DOMED,SST303,5/16-NOM	2.
26		503155	PAN,PRE634,OUTPUT DRIVE	1.
27		501230	COVER/BASE PAN SUPPORT,P-SIGMA	1.0
28		137354	SHEET,PVC,EUROGRY,1/4X48X100IN	24.0
29		069565	PVC,1/2 X 1/2	24.0
30		067246	PVC,1/2 X 6	65.750
31		069686	PVC,1/2 X 1	65.750
31		069686	PVC,1/2 X 1	65.750



## **9.7 General Parts Ordering Instructions**

To order replacement parts refer to the appropriate section of Chapter 9, locate the desired part, its part number, and its name and description.

**WHEN ORDERING REPLACEMENT PARTS, SELECT THOSE PART NUMBERS, WHICH PERTAIN TO THE CONVEYOR SIZE AND THE PROCESS STATIONS IN YOUR SYSTEM.**

**IMPORTANT: WHEN ORDERING REPLACEMENT PARTS, ALWAYS INDICATE SYSTEM SERIAL NUMBER, MODULE SERIAL NUMBER, PART NAME, PART NUMBER, PART DESCRIPTION, AND EQUIPMENT CONVEYOR WIDTH. CONTACT THE CUSTOMER SERVICE PARTS DEPARTMENT FOR PLACING OF ORDERS. (SEE FOLLOWING PAGE)**

**NOTE: ELECTRICAL PART NUMBERS:** Part numbers for electrical parts used in this system are shown on the electrical schematic and layout drawings provided with your equipment. These drawings are placed inside the remote electrical enclosure when your system is ready for shipment from Chemcut. Refer to these electrical drawings to locate part numbers for the electrical components in your system.

**IMPORTANT: THE ELECTRICAL SCHEMATICS AND LAYOUTS SHIPPED WITH YOUR SYSTEM ARE THE ONLY DOCUMENTATION FOR THE PARTS USED IN THE ELECTRICAL CONTROL SYSTEM.** At least one set of these electrical drawings should be kept with the instruction manual to be used as your electrical parts reference.

Chemcut makes every effort to maintain an adequate supply of replacement parts for all of our customer's needs. For fastest response of your parts order or for technical information, refer to the following page for our 1-800 number.



**9.8 Parts Ordering Call 1-800-243-6288**

Ordering Parts & Service for your  
Wet Processing Equipment  
Is now easier than ever!

**Call 1-800-243-6288**  
***It's as simple as that!***

*Chemcut Corp. manufactures and services quality WET PROCESSING EQUIPMENT.*

*No matter where you are, Quality Original Equipment Parts & Factory Trained Service for your Chemcut Equipment is but a phone call away!*

*Your call will be automatically routed to ensure that you will receive fast, courteous service when you want it.*

*And, we offer full service and maintenance on every make of wet processing equipment too! Give it a try; we're here to keep you in production.*

**CHEMCUT CORP. • 500 Science Park • State College, PA 16803**  
**Tel (814) 272-2800 • FAX (814) 272-5208**

## 9.9 Recommended Spare Parts

### SYSTEM C60-500

It is recommended that the parts listed in this section be carried as spares by users of system C60-500. The information provided consists of recommended stocking quantity for each part, CHEMCUT part number for each part, and name and description of each part.

<u>Part Number</u>	<u>Description</u>	<u>Qty.</u>	<u>Unit\$</u>	<u>Ext\$</u>
007526	VALVE, SOL, PAINT, BRS, 1/2NPT, N/C	1	222.00	222.00
011905	VALVE, SOL, PAINT, BRS, 3/4NPT, N/C	1	259.00	259.00
012758	HYDROMETER, SPECIFIC-GRAVITY	1	25.50	25.50
018836	SEAL, O-RING, 2-330, EPDM, BLACK	1	5.40	5.40
019748	SEAL, O-RING, 2-121, VITON, BROWN	10	.65	6.50
023082	LAMP, INCANDESCENT	1	2.95	2.95
023651	WASHER, THRUST, TFE, .030	7	1.65	11.55
023759	FUSE, CART, FNM-5 A, 250 VOLT	1	3.90	3.90
027320	SCREW, CAP, PVC, 5/16-18X1/2"LG	1	3.85	3.85
029913	HOUSING, MAGNET, PVC, 3/8	1	21.60	21.60
031926	SEAL, O-RING, 2-232, EPDM, BLACK	1	2.15	2.15
034665	SWITCH ASSY, REED, PVC, 12'	1	49.00	49.00
035031	SEAL, V-RING, V-12S, NITRILE	1	3.70	3.70
040107	SWITCH, LIQUID LEVEL, PPL, COMPAC	1	40.50	40.50
043105	SOCKET, RELAY BLADE TYPE	1	19.10	19.10
043734	INSERT, SIDERAIL, RPE, 3/8DIA	8	5.10	40.80
044191	RELAY, 4PDT, 120VAC-C	1	15.00	15.00
044192	RELAY, 4PDT, 24 VDC-C	1	13.60	13.60
044426	INSERT, SIDERAIL, RPE, 3/8, DEWEBB	7	5.95	41.65
044648	GEAR, SPUR, RPE, 15T, EXT	4	5.75	23.00
044652	INSERT, SIDERAIL, RPE, DE-WEBBED	1	7.45	7.45
046372	SWITCH ASSY, EMERGENCY STOP	1	57.50	57.50
046914	FUSE, CART, FNM-2 A, 250 VOLT	1	8.65	8.65
073711	NOZZLE, SCRD, PVDF, 1.5GPM, 70DEG	10	8.05	80.50
075246	SEAL, O-RING, 2-209, EPDM, BLACK	20	.60	12.00
080192	SWITCH, FLUID LEVEL, CS/SIGMA	1	71.00	71.00
081141	SWITCH ASSY, ILLUMINATED, STOP	1	55.00	55.00
081142	SWITCH ASSY, ILLUMINATED, START	1	55.00	55.00
084577	CARAPACE SUBASS, LARGE, RPP, NPT	1	268.00	268.00
088395	CAP, PIPE, PVC, MACHINED	3	15.95	47.85
103650	GAUGE, PRESS, 0-60/4BAR, W/ISOL	1	102.00	102.00
109975	PIN ASSY, INT GEAR, RPP	1	20.80	20.80
114264	CONTROLLER, DC MOTOR SPEED	1	145.00	145.00
115941	FUSE, CART, ABC-10 A, 250 VAC	1	2.40	2.40
116673	INSERT, SIDERAIL, RPE, BLIND	21	5.30	111.30
117858	SENSOR, PHOTOELECTRIC, 10-30 VDC	1	153.00	153.00

118289	FUSE, CART, CLASS J, 10A, 600 VOLT	1	11.90	11.90
118290	FUSE, CART, CLASS J, 15A, 600 VOLT	1	11.90	11.90
118291	FUSE, CART, CLASS J, 20A, 600 VOLT	1	9.55	9.55
119055	FUSE, CART, ABC-2 A, 250 VOLT	1	3.20	3.20
123440	CONTACTOR, IEC, 30A, 10HP, AB	1	77.50	77.50
125942	METER, LOOP POWERED, 3-1/2 LCD	1	173.00	173.00
128115	TRANSMITTER, ISOLATOR, UNIVERSAL	1	492.00	492.00
146043	RELAY, OVERLOAD, MCS 1-2.9A, AB	1	53.50	53.50
146045	RELAY, OVERLOAD, MCS 3.7-12A, AB	1	53.00	53.00
148916	KEY, SQ TI, 3/16X1-1/2LG	1	7.60	7.60
156728	GEAR, SPUR, RPP, 15T, 3/8, MOD	1	7.25	7.25
164282	TIMER, OMRON, 24-230V AC/DC	1	108.00	108.00
164422	PROBE, T-S/OT, 132 F, 14 IN, POLY	1	165.00	165.00
170033	CAM, OSC, 5762, TI	1	167.00	167.00
170034	COUPLING, DRIVE, OSC, TI	1	171.00	171.00
170069	GEAR, DRIVE, PVC, 8P, 2.000, 24T	1	15.70	15.70
170076	BLOCK, BEARING, RPE/TI	2	24.55	49.10
170131	SPRAYTUBE ASSY, PEM, XL	1	96.50	96.50
170173	LINK, OSCILLATION, RPP, XL	7	19.60	137.20
170787	MOTOR, GEAR, DC, 1/8HP, 30RPM, TACH	1	626.00	626.00
402227	SPROCKET, BELT, HTD, BLK, 3/4ID, 24	1	98.00	98.00
600521	INSERT, SIDERAIL, 1.437, DEWEBB	1	13.95	13.95
600523	INSERT, SIDERAIL, RPE, 3/8, BLIND	1	10.50	10.50
600590	GEAR, MITER/SPUR, RPE, "D", 1.419	2	2.60	5.20
600592	GEAR, MITER, LINE, RPP, 13T, XL *	6	3.95	23.70

Total cost: 4595.45

















## **9.10 General Parts Ordering Instructions**

To order replacement parts refer to the appropriate section of Chapter 9, locate the desired part, its part number, and its name and description.

**WHEN ORDERING REPLACEMENT PARTS, SELECT THOSE PART NUMBERS, WHICH PERTAIN TO THE CONVEYOR SIZE AND THE PROCESS STATIONS IN YOUR SYSTEM.**

**IMPORTANT: WHEN ORDERING REPLACEMENT PARTS, ALWAYS INDICATE SYSTEM SERIAL NUMBER, MODULE SERIAL NUMBER, PART NAME, PART NUMBER, PART DESCRIPTION, AND EQUIPMENT CONVEYOR WIDTH. CONTACT THE CUSTOMER SERVICE PARTS DEPARTMENT FOR PLACING OF ORDERS. (SEE FOLLOWING PAGE)**

**NOTE: ELECTRICAL PART NUMBERS:** Part numbers for electrical parts used in this system are shown on the electrical schematic and layout drawings provided with your equipment. These drawings are placed inside the remote electrical enclosure when your system is ready for shipment from Chemcut. Refer to these electrical drawings to locate part numbers for the electrical components in your system.

**IMPORTANT: THE ELECTRICAL SCHEMATICS AND LAYOUTS SHIPPED WITH YOUR SYSTEM ARE THE ONLY DOCUMENTATION FOR THE PARTS USED IN THE ELECTRICAL CONTROL SYSTEM.** At least one set of these electrical drawings should be kept with the instruction manual to be used as your electrical parts reference.

Chemcut makes every effort to maintain an adequate supply of replacement parts for all of our customer's needs. For fastest response of your parts order or for technical information, refer to the following page for our 1-800 number.





**9.11 Parts Ordering Call 1-800-243-6288**

Ordering Parts & Service for your  
Wet Processing Equipment  
Is now easier than ever!

**Call 1-800-243-6288**  
***It's as simple as that!***

*Chemcut Corp. manufactures and services quality WET PROCESSING EQUIPMENT.*

*No matter where you are, Quality Original Equipment Parts & Factory Trained Service for your Chemcut Equipment is but a phone call away!*

*Your call will be automatically routed to ensure that you will receive fast, courteous service when you want it.*

*And, we offer full service and maintenance on every make of wet processing equipment too! Give it a try; we're here to keep you in production.*

**CHEMCUT CORP. • 500 Science Park • State College, PA 16803**  
**Tel (814) 272-2800 • FAX (814) 272-5208**

## 9.12 Recommended Spare Parts

### SYSTEM C60-500

It is recommended that the parts listed in this section be carried as spares by users of system C60-500. The information provided consists of recommended stocking quantity for each part, CHEMCUT part number for each part, and name and description of each part.

<u>Part Number</u>	<u>Description</u>	<u>Qty.</u>	<u>Unit\$</u>	<u>Ext\$</u>
007526	VALVE, SOL, PAINT, BRS, 1/2NPT, N/C	1	222.00	222.00
011905	VALVE, SOL, PAINT, BRS, 3/4NPT, N/C	1	259.00	259.00
012758	HYDROMETER, SPECIFIC-GRAVITY	1	25.50	25.50
018836	SEAL, O-RING, 2-330, EPDM, BLACK	1	5.40	5.40
019748	SEAL, O-RING, 2-121, VITON, BROWN	10	.65	6.50
023082	LAMP, INCANDESCENT	1	2.95	2.95
023651	WASHER, THRUST, TFE, .030	7	1.65	11.55
023759	FUSE, CART, FNM-5 A, 250 VOLT	1	3.90	3.90
027320	SCREW, CAP, PVC, 5/16-18X1/2"LG	1	3.85	3.85
029913	HOUSING, MAGNET, PVC, 3/8	1	21.60	21.60
031926	SEAL, O-RING, 2-232, EPDM, BLACK	1	2.15	2.15
034665	SWITCH ASSY, REED, PVC, 12'	1	49.00	49.00
035031	SEAL, V-RING, V-12S, NITRILE	1	3.70	3.70
040107	SWITCH, LIQUID LEVEL, PPL, COMPAC	1	40.50	40.50
043105	SOCKET, RELAY BLADE TYPE	1	19.10	19.10
043734	INSERT, SIDERAIL, RPE, 3/8DIA	8	5.10	40.80
044191	RELAY, 4PDT, 120VAC-C	1	15.00	15.00
044192	RELAY, 4PDT, 24 VDC-C	1	13.60	13.60
044426	INSERT, SIDERAIL, RPE, 3/8, DEWEBB	7	5.95	41.65
044648	GEAR, SPUR, RPE, 15T, EXT	4	5.75	23.00
044652	INSERT, SIDERAIL, RPE, DE-WEBBED	1	7.45	7.45
046372	SWITCH ASSY, EMERGENCY STOP	1	57.50	57.50
046914	FUSE, CART, FNM-2 A, 250 VOLT	1	8.65	8.65
073711	NOZZLE, SCRD, PVDF, 1.5GPM, 70DEG	10	8.05	80.50
075246	SEAL, O-RING, 2-209, EPDM, BLACK	20	.60	12.00
080192	SWITCH, FLUID LEVEL, CS/SIGMA	1	71.00	71.00
081141	SWITCH ASSY, ILLUMINATED, STOP	1	55.00	55.00
081142	SWITCH ASSY, ILLUMINATED, START	1	55.00	55.00
084577	CARAPACE SUBASS, LARGE, RPP, NPT	1	268.00	268.00
088395	CAP, PIPE, PVC, MACHINED	3	15.95	47.85
103650	GAUGE, PRESS, 0-60/4BAR, W/ISOL	1	102.00	102.00
109975	PIN ASSY, INT GEAR, RPP	1	20.80	20.80
114264	CONTROLLER, DC MOTOR SPEED	1	145.00	145.00
115941	FUSE, CART, ABC-10 A, 250 VAC	1	2.40	2.40
116673	INSERT, SIDERAIL, RPE, BLIND	21	5.30	111.30
117858	SENSOR, PHOTOELECTRIC, 10-30 VDC	1	153.00	153.00

118289	FUSE, CART, CLASS J, 10A, 600 VOLT	1	11.90	11.90
118290	FUSE, CART, CLASS J, 15A, 600 VOLT	1	11.90	11.90
118291	FUSE, CART, CLASS J, 20A, 600 VOLT	1	9.55	9.55
119055	FUSE, CART, ABC-2 A, 250 VOLT	1	3.20	3.20
123440	CONTACTOR, IEC, 30A, 10HP, AB	1	77.50	77.50
125942	METER, LOOP POWERED, 3-1/2 LCD	1	173.00	173.00
128115	TRANSMITTER, ISOLATOR, UNIVERSAL	1	492.00	492.00
146043	RELAY, OVERLOAD, MCS 1-2.9A, AB	1	53.50	53.50
146045	RELAY, OVERLOAD, MCS 3.7-12A, AB	1	53.00	53.00
148916	KEY, SQ TI, 3/16X1-1/2LG	1	7.60	7.60
156728	GEAR, SPUR, RPP, 15T, 3/8, MOD	1	7.25	7.25
164282	TIMER, OMRON, 24-230V AC/DC	1	108.00	108.00
164422	PROBE, T-S/OT, 132 F, 14 IN, POLY	1	165.00	165.00
170033	CAM, OSC, 5762, TI	1	167.00	167.00
170034	COUPLING, DRIVE, OSC, TI	1	171.00	171.00
170069	GEAR, DRIVE, PVC, 8P, 2.000, 24T	1	15.70	15.70
170076	BLOCK, BEARING, RPE/TI	2	24.55	49.10
170131	SPRAYTUBE ASSY, PEM, XL	1	96.50	96.50
170173	LINK, OSCILLATION, RPP, XL	7	19.60	137.20
170787	MOTOR, GEAR, DC, 1/8HP, 30RPM, TACH	1	626.00	626.00
402227	SPROCKET, BELT, HTD, BLK, 3/4ID, 24	1	98.00	98.00
600521	INSERT, SIDERAIL, 1.437, DEWEBB	1	13.95	13.95
600523	INSERT, SIDERAIL, RPE, 3/8, BLIND	1	10.50	10.50
600590	GEAR, MITER/SPUR, RPE, "D", 1.419	2	2.60	5.20
600592	GEAR, MITER, LINE, RPP, 13T, XL *	6	3.95	23.70

Total cost: 4595.45

# 10 Warranty

## Chemcut Corp. TERMS AND CONDITIONS OF SALE - ELECTRONICS EQUIPMENT GROUP

*These are the terms and conditions of sale governing the transaction on front hereof. The following terms and conditions of sale supersede any conflicting terms included in Buyer's purchase order.*

### **1. Drawings, Specifications, Confidentiality and Trademarks**

Any drawings, specifications or descriptions accompanying the quotation are estimates and approximations and do not represent the terms of the Agreement between Buyer and Chemcut. Any drawings, documentation or information delivered with a quotation are the property of Chemcut and shall be held in confidence by Buyer. Buyer agrees to protect the trademarks of Chemcut and not to remove or deface such trademarks affixed to any goods or equipment sold by Chemcut.

### **2. Delivery**

***All sales by Chemcut are F.O.B. point of shipment. By accepting delivery F.O.B. at point of shipment, Buyer acknowledges that it shall provide, at its cost, all facilities for shipment, insurance, unloading and installation of equipment sold by Chemcut. All reasonable means will be used to make shipment at the time specified, but we assume no liability for loss or damage arising from delays due to fires, strikes, or any causes beyond our control. Quoted deliveries from stock are subject to prior sale.***

### **3. Payment**

Terms of payment shall be net 30 days from date of invoice.

***Should buyer for any reason fail to make timely payments, without affecting any other right which Chemcut may have, Chemcut shall be entitled to interest accruing at the rate which is the lower of 1% per month or the highest aggregate rate of interest permitted by law. Chemcut shall also have the right to offset the outstanding balance against any payments due by Chemcut.***

### **4. Security Interest in Goods Sold**

Upon placing an order for goods or equipment, Buyer grants to Chemcut a security interest in the goods or equipment purchased as security for the satisfaction of Buyer's account balance. Buyer shall deliver to Chemcut at Chemcut's request, such executed financing statements, continuation statements and other documents as are required to perfect, preserve and continue Chemcut's security interest in such goods or equipment. Upon default in the payment terms agreed upon by the parties, Chemcut may declare all obligations secured hereby immediately due and payable and shall have the remedies of a secured party under the Uniform Commercial Code.

### **5. Equipment and Parts Warranty**

There are no warranties, expressed or implied by either distributor or the manufacturer on new equipment except the manufacturer's warranty against defects in material and workmanship set forth below:

***Chemcut warrants new equipment manufactured by Chemcut and delivered to the original retail purchaser F.O.B. Chemcut's factory, to be free from defects in material and workmanship under normal use and service, for a period of one year from delivery of the equipment or for the first 2000 hours of operation whichever occurs earlier. Chemcut***

**warrants parts for thirty (30) days from the date of purchase. These warranties are subject to the following limitations to which the Buyer expressly agrees:**

Chemcut's obligation under this warranty is limited solely to repairing or replacing, at our option and without charge, FOB Chemcut's factory in State College, PA with transportation prepaid by the Buyer within the warranty period and which, upon examination by Chemcut shall be found to be reasonable satisfaction to have been thus defective. THIS REMEDY IS EXPRESSLY SUBSTITUTED FOR ANY AND ALL OTHER REMEDIES POSSIBLE UNDER THE UNIFORM COMMERCIAL CODE, STATE, COMMON OR STATUTORY LAW OR OTHERWISE.

**B. The provisions of this warranty SHALL NOT APPLY:**

1. To any equipment which has been subject to misuse, negligence or accident or which has been repaired or altered outside Chemcut's factory in any way so as to, in Chemcut's sole but reasonable judgement, affect its performance and reliability.
  2. To any equipment or parts that are used with chemistry or temperature that is not compatible with the materials of construction. Compatibility of chemistry and temperature must be approved in writing by Chemcut..
  3. To any equipment and parts that are operated with the safety interlock system disconnected or bypassed.
  4. To any equipment or parts manufactured pursuant to design or specifications supplied by the Buyer which have not been formally accepted by Chemcut.
  5. To any equipment, parts or components which, under normal usage, would not or are not expected to last the warranty period, i.e. "wear" items (i.e. gears, sprockets, bearings, gear couplings, nozzles, oscillation assemblies, manifold packing, and manifold adapters).
  6. To any consumable parts or components with limited use potential, (i.e. water filters, air filters, scrubbing/deburring brushes, lamps, filters, thin material parts, drive belts, probes and brushes).
  7. To any equipment and parts which have not been subject to proper maintenance as set forth in the maintenance schedule provided. Maintenance records should be kept for verification.
- C. Chemcut shall not be liable for any damages, whether direct or indirect, economic, commercial, incidental, or consequential, and whether arising from Chemcut's negligence, breach of contract, product liability, warranty or any other reason.
- D. The 2000 hours of operation shall be determined solely by a timing device, which is built in the equipment. If, upon examination by Chemcut, it is determined that this timing device or its electrical connections have been tampered with to delay the expiration of this warranty, this warranty shall be immediately null and void.
- E. THIS WARRANTY IS EXPRESSLY IN LIEU OF ANY OTHER WARRANTIES, EXPRESSED OR IMPLIED INCLUDING ANY IMPLIED OR EXPRESSED WARRANTY OF MERCHANTABILITY, SUITABILITY OR FITNESS FOR A PARTICULAR PURPOSE and Chemcut neither assumes nor authorizes another to assume any liability in connection with such equipment, except as provided above.
- F. This warranty does not apply to equipment not manufactured by Chemcut. For equipment furnished, but not manufactured by Chemcut, Chemcut assigns to the Buyer any warranty and/or claim it may have against the manufacturer or supplier of the equipment.

**6. Taxes and Permits**

Buyer shall be responsible for all taxes on the sale, installation and use of goods sold by Chemcut. Buyer shall be responsible for obtaining all necessary permits and approvals.

**7. Termination**

Accepted purchase orders can be terminated only with the consent of Chemcut and in the event of such termination, Chemcut shall be entitled to recover its costs incurred as a result of its performance, including administrative, labor and materials, and a reasonable profit. Chemcut shall have the option to terminate a purchase order in the event of Buyer's dissolution, insolvency, or business failure, the appointment of a custodian, liquidator, receiver, or trustee of or for any part of Buyer's property, an assignment for the benefit of creditors by, or the commencement of any proceedings under any bankruptcy or insolvency law by or against the Buyer.

8. **Change Orders; Modifications**

Any change orders requested by Buyer shall be in writing and shall be treated as additional purchase orders, subject to acceptance by Chemcut.

9. **Field Service**

The schedule and cost of any field service to be provided by Chemcut shall be stated in the quotation. Chemcut will provide additional field service only upon its acceptance of an order for service and at its rates prevailing at the time.

10. **Installation Checklist**

Installation checkout is provided with the purchase of new Chemcut systems. This is performed by a qualified Chemcut representative after the system is completely installed to insure proper start up of the system. Included with the checkout is a training session of up to (4) hours in operation, care and maintenance of the system, both electrical and mechanical. NOTE: Additional training is available at a cost dependent upon the complexity of the system. For available training courses and cost information, please contact the Customer Service Department at Chemcut, State College at (814) 238-0514 or 1-800-243-6288.

11. **Manuals and Electrical Schematics**

One standard Chemcut equipment manual and one (1) set of electrical schematics are provided with every new Chemcut system.

12. **Clerical Errors**

Chemcut reserves the right to correct clerical errors.

13. **Force Majeure**

Chemcut shall not be liable for any damage or penalty for delays in delivery, installation, complying with the warranty provisions hereunder due to acts of God, acts or omissions of the customer, acts of Civil or Military authorities, government regulations or priorities, fires, floods, epidemics, quarantine restrictions, war, riots, strikes, differences with workmen, accidents to machinery, inability to obtain the necessary materials of manufacturing facilities, delays in transportation, failure of or delay in furnishing correct or complete information by customer with respect to details of work to be performed hereunder, impossibility of performance or any other cause or causes beyond the control of Chemcut, whether or not similar to the foregoing. In the event of any delay caused bas aforesaid, the delivery, installation, completion and/or warranty performance data shall be extended for a period equal to any such delay, and this contract shall not be void or voidable as a result of any such delay. CHEMCUT SHALL UNDER NO CIRCUMSTANCES BE LIABLE FOR SPECIAL OR CONSEQUENTIAL DAMAGES FOR DELAYS OR FAILURE TO GIVE NOTICE OF DELAY.

14. **Modifications; Governing Law**

The Agreement represented by an accepted purchase order may be modified only by a written agreement between Chemcut and Buyer. Such agreement will be governed by and construed in accordance with Pennsylvania Law. If any provision of the

agreement between Chemcut and Buyer shall be held illegal, invalid or unenforceable in any jurisdiction, it shall be ineffective in such jurisdiction only to the extent of such illegality, invalidity or unenforceability, and such illegality invalidity or unenforceability shall not invalidate the remaining provisions of such agreement.

**15. Claims**

- A. Buyer shall have no right to reject nonconforming goods or to rescind, but BUYER'S EXCLUSIVE REMEDY SHALL BE A CLAIM FOR MONETARY ADJUSTMENT,, or al Seller's option, shipment of conforming goods and return of disputed goods to Chemcut. Buyer shall afford Chemcut prompt and reasonable opportunity to inspect all material as to which any claim is made. If Chemcut and Buyer are unable to reach settlement of any claim relating to material covered hereby. Buyer must institute legal action against Chemcut within one (1) year after such claim arises and thereafter all such claims shall be barred notwithstanding any statutory period of limitation to the contrary.
- B. CHEMCUT'S LIABLITY ON ANY CLAIM, WHETHER BASED IN NEGLIGENCE, TORT, CONTRACT OR OTHERWISE, WITH RESPECT TO MATERIAL DELIVERED HEREUNDER OR TO NONDELIVERY OF MATERIAL, SHALL NOT EXCEED THE PURCHASE PRICE OF THAT PORTION OF THE MATERIAL IN RESPECT OF WHICH CLAIM IS MADE. IN NO EVENT SHALL SELLER BE LIABLE FOR INCIDENTAL OR CONSEQUENTIAL DAMAGES. Buyer assumes all risk of loss and liability from use or resale of any material delivered.

**16. Equipment and Parts Return**

All returns of equipment and/or spare parts will be subject to a 25% restocking fee.

QD 1072

REV #1

REV. DATE 5-1-2002

# 11 Chemcut Contacts

Contents.....		Page
11.1	General .....	233
11.2	State College contact information.....	233
11.3	Eastern Region, U.S. contact information .....	234
11.4	Central Region, U.S. contact information .....	235
11.5	Western Region, U.S. contact information.....	236
11.6	Europe Region contact information .....	237
11.7	Asia Region contact information.....	238



## 11.1 General

Chemcut Corp. main equipment facility is located in State College PA. This facility contains the sales, purchasing, engineering, manufacturing, information systems, customer service, (parts), and technical support functions for Chemcut Corp. equipment business.

In addition to the State College facility, several regional sales and service offices exist throughout the world. The United States is divided into 3 regions (East, Central, and West). Europe and Asia are also considered regions. Each of these 5 regions, has sales and/or service organizations to directly support customers within the geographic region.

The information contained in this section of the technical documentation, is intended to identify the proper contact point within the Chemcut Corp. organization.

## 11.2 State College contact information

Address:

Chemcut Corp.  
500 Science Park Road  
State College PA  
16803

Phone:

814-272-2800 (main switchboard, follow the automated menu)  
800-243-6288 (toll free within the U.S.)

Email:

[customer.support@chemcut.net](mailto:customer.support@chemcut.net) (support)  
[marketing@chemcut.net](mailto:marketing@chemcut.net) (request sales literature)  
[tech.support@chemcut.net](mailto:tech.support@chemcut.net) (technical assistance)  
[parts@chemcut.net](mailto:parts@chemcut.net) (parts)

## 11.3 Eastern Region, U.S. contact information

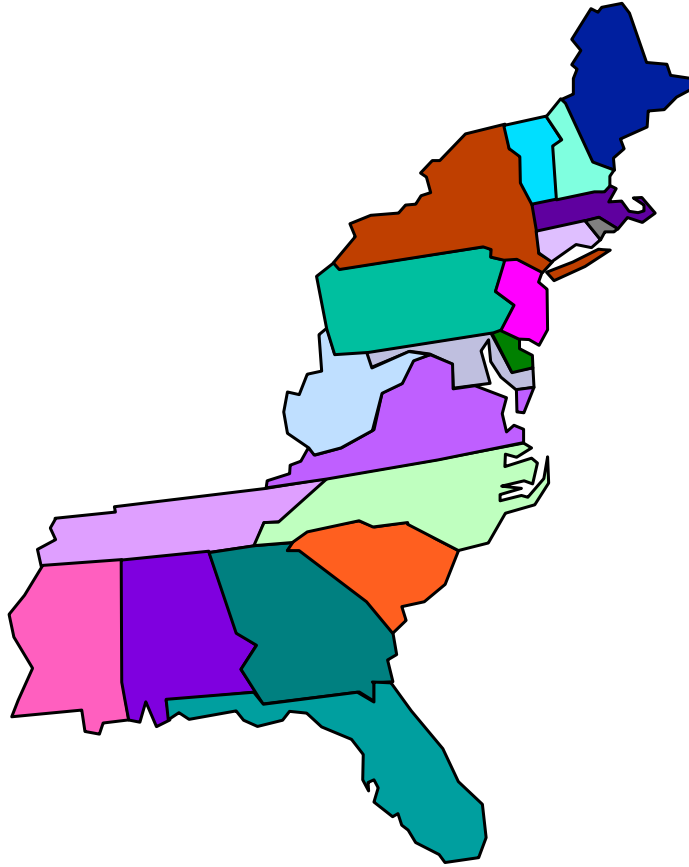

Phone:

814-272-2800 (main switchboard, follow the automated menu)  
800-243-6288 (toll free within the U.S., follow the automated menu)

Email:

[sales.east@chemcut.net](mailto:sales.east@chemcut.net) (sales)  
[service.east@chemcut.net](mailto:service.east@chemcut.net) (service)  
[customer.support@chemcut.net](mailto:customer.support@chemcut.net) (support)  
[tech.support@chemcut.net](mailto:tech.support@chemcut.net) (technical assistance)  
[parts@chemcut.net](mailto:parts@chemcut.net) (parts)

## 11.4 Central Region, U.S. contact information

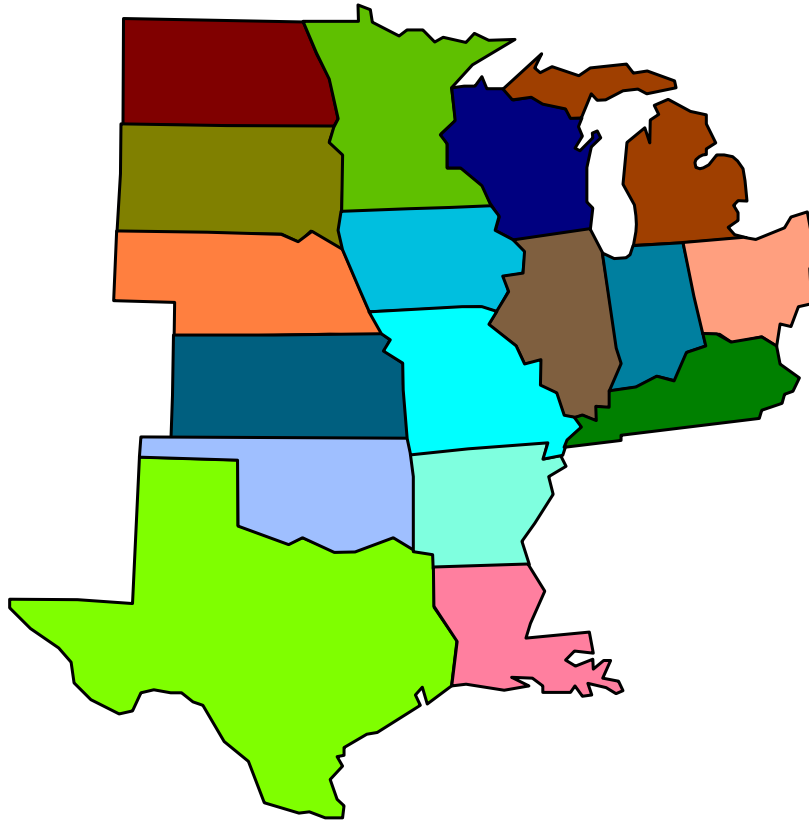

Phone:

814-272-2800 (main switchboard, follow the automated menu)  
800-243-6288 (toll free within the U.S., follow the automated menu)

Email:

[sales.central@chemcut.net](mailto:sales.central@chemcut.net) (sales)  
[service.central@chemcut.net](mailto:service.central@chemcut.net) (service)  
[customer.support@chemcut.net](mailto:customer.support@chemcut.net) (support)  
[tech.support@chemcut.net](mailto:tech.support@chemcut.net) (technical assistance)  
[parts@chemcut.net](mailto:parts@chemcut.net) (parts)

## 11.5 Western Region, U.S. contact information

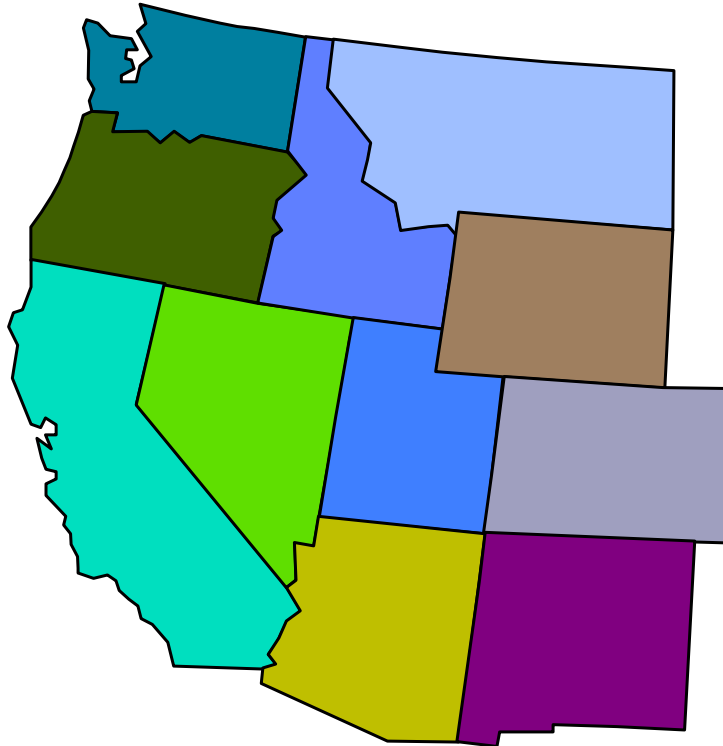

Phone:

814-272-2800 (main switchboard, follow the automated menu)  
800-243-6288 (toll free within the U.S., follow the automated menu)

Email:

[sales.west@chemcut.net](mailto:sales.west@chemcut.net) (sales)  
[service.west@chemcut.net](mailto:service.west@chemcut.net) (service)  
[customer.support@chemcut.net](mailto:customer.support@chemcut.net) (support)  
[tech.support@chemcut.net](mailto:tech.support@chemcut.net) (technical assistance)  
[parts@chemcut.net](mailto:parts@chemcut.net) (parts)

## 11.6 Europe Region contact information

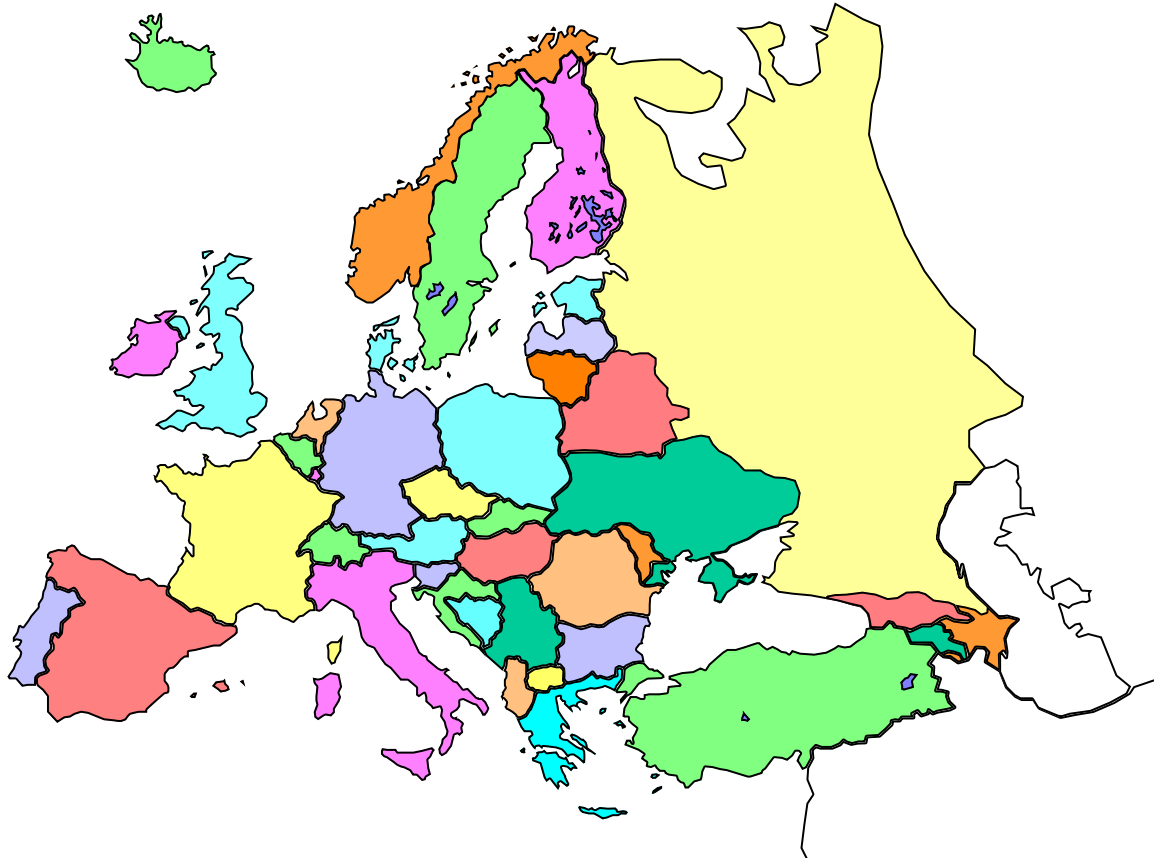

Phone:

001-814-272-2800 (main switchboard, follow the automated menu)

Email:

[sales.europe@chemcut.net](mailto:sales.europe@chemcut.net) (sales)  
[service.europe@chemcut.net](mailto:service.europe@chemcut.net) (service)  
[customer.support@chemcut.net](mailto:customer.support@chemcut.net) (support)  
[tech.support@chemcut.net](mailto:tech.support@chemcut.net) (technical assistance)  
[parts@chemcut.net](mailto:parts@chemcut.net) (parts)

## 11.7 Asia Region contact information



Phone:

001-814-272-2800 (main switchboard, follow the automated menu)

Email:

[sales.asia@chemcut.net](mailto:sales.asia@chemcut.net) (sales)  
[service.asia@chemcut.net](mailto:service.asia@chemcut.net) (service)  
[customer.support@chemcut.net](mailto:customer.support@chemcut.net) (support)  
[tech.support@chemcut.net](mailto:tech.support@chemcut.net) (technical assistance)  
[parts@chemcut.net](mailto:parts@chemcut.net) (parts)