

CLTM12-Series

Solid State Load Controller

PRODUCT WEBPAGE

request sample, configure part, watch video



The CLTM12-S is a compact, solid state load controller with 12 high-side outputs, 4 digital inputs, 3 discrete inputs, 2 address lines, and a CAN baud rate select line. It provides fast, low-loss, solid state on/off switching along with short circuit protection for each output, as well as load status and power diagnostics. Relative to electromechanical relays, the CLTM12 electronic control module increases thermal efficiency by providing lower power dissipation and higher power-to-weight densities.

6.5–32 VDC **IP69K Sealing**
 When Connected

Typical Applications

- On/Off-Highway
- Directional and Hazard Signals
- Site and Work Lights
- Headlamps and Sidelights
- Beacon and Alarm Systems
- Cab Illumination

Tech Specs

Mechanical

| | |
|-----------------------------------|-----------------------------------|
| Dimensions (L x W x H) | 5.7" x 4.2" x 1.33" |
| Weight (max) | 1.25 lbs. (0.567 kg) |
| Torque Value (voltage input stud) | 20 – 25 in-lbs. [2.26 – 2.82 N-m] |
| J2 Mating connector | Molex P/N 334721201 |
| J1 Mating connector | Molex P/N 0334721601 |

Electrical

| | |
|----------------------|--|
| Voltage Input | 6.5 to 32VDC |
| Max Current Capacity | 75 Amps |
| Serial Communication | CAN J1939 |
| 8 High Side Outputs | 10 Amps each |
| 4 High Side Outputs | 5 Amps each |
| 2 Address Lines | Active Low |
| Baud Rate Select | Connector J1 Pin 3: 250 Kbit/s open; connector J1 Pin 3 to connector J1 Pin 15: 500 Kbit/s |
| 4 Digital Inputs | Active High & Open |
| 3 Discrete Inputs | Active High & Open |
| Sleep Mode Current | <3mA |
| Operating Voltage | SAE J1455, Section 4.13.1 |
| Over Voltage | SAE J1455, Section 4.13.1 |
| Reverse Polarity | SAE J1455, Section 4.13.1 |
| Short Circuit | SAE J1455, Section 4.13.1 |
| Power Up | SAE J1455, Section 4.13.1 |

Electromagnetic

| | |
|-------------------------------|--|
| Transient Immunity | ISO 11451-1 & 11452-2 |
| Transient Emissions | ISO 13766, Section 5 Annex D And Annex E |
| Conducted Transients | ISO 7637-2, Annex A |
| Electrostatic Discharge (ESD) | ISO 13766 & ISO 10605 |

Environmental

| | |
|------------------------------|--|
| Operating Temp. | -40° to +85°C |
| Storage Temperature | -40° to +85°C |
| High Temperature | IEC 60068-2-2, Test Bb |
| Low Temperature | IEC 60068-2-1, Test Ad |
| Temp. Cycling (Operational) | IEC 60068-2-14, Test Nb |
| Temp. Shock (Storage) | IEC 60068-2-14, Test Na |
| Simulated Solar Radiation | IEC 60068-2-5, Procedure B |
| Altitude (Transport) | IEC 60068-2-13 |
| Altitude (Operational) | IEC 60068-2-13, Test M: Low air pressure |
| Humidity (Soak) | IEC 60068-2-78 |
| Humidity (Cyclic) | IEC 60068-2-30 |
| Sealing Protection | IP69k in accordance with DIN 40050-9 and IEC 60529 sections 13.4, 13.6, & 14 |
| Mechanical Shock (Drop Test) | IEC 60068-2-32, Test Ed: Free Fall, Procedure 1. |
| Mechanical (Shock) | 60068-2-27 |
| Mechanical (Bump) | 60068-2-29 |
| Vibration (Sine) | IEC 60068-2-6 |
| Vibration (Random) | IEC 60068-2-64, Method 1 |
| Vibration (Resonant Search) | IEC 60068-2-6 |
| Chemical Resistance | IEC 60068-2-74, Test Class B (Engine oil, Diesel, Hydraulic Oil, Ethylene Glycol, Urea Nitrogen, Liquid lime, NPX fertilizer, Ammonia, Calcium chloride) |
| Salt Spray | IEC 60068-2-52, Test Kb |
| Ozone | ASTM D1171-99, Method 1 |

Software Interface Integration

Click below on integrating the VM-Series into J1939 CAN network:

www.carlingtech.com/sites/default/files/documents/cltm12-s-series_interface.pdf

Ordering Scheme

Sample Part No. **CLTM 12 - S STANDARD**

Selection 1 2 3 4

1. SERIES

CLTM Control Module

3. SYSTEM

S Secondary

2. OUTPUT

12 12 Outputs

4. TYPE

Standard Off-the-Shelf Hardware

Dimensional Specs

inches [millimeters]

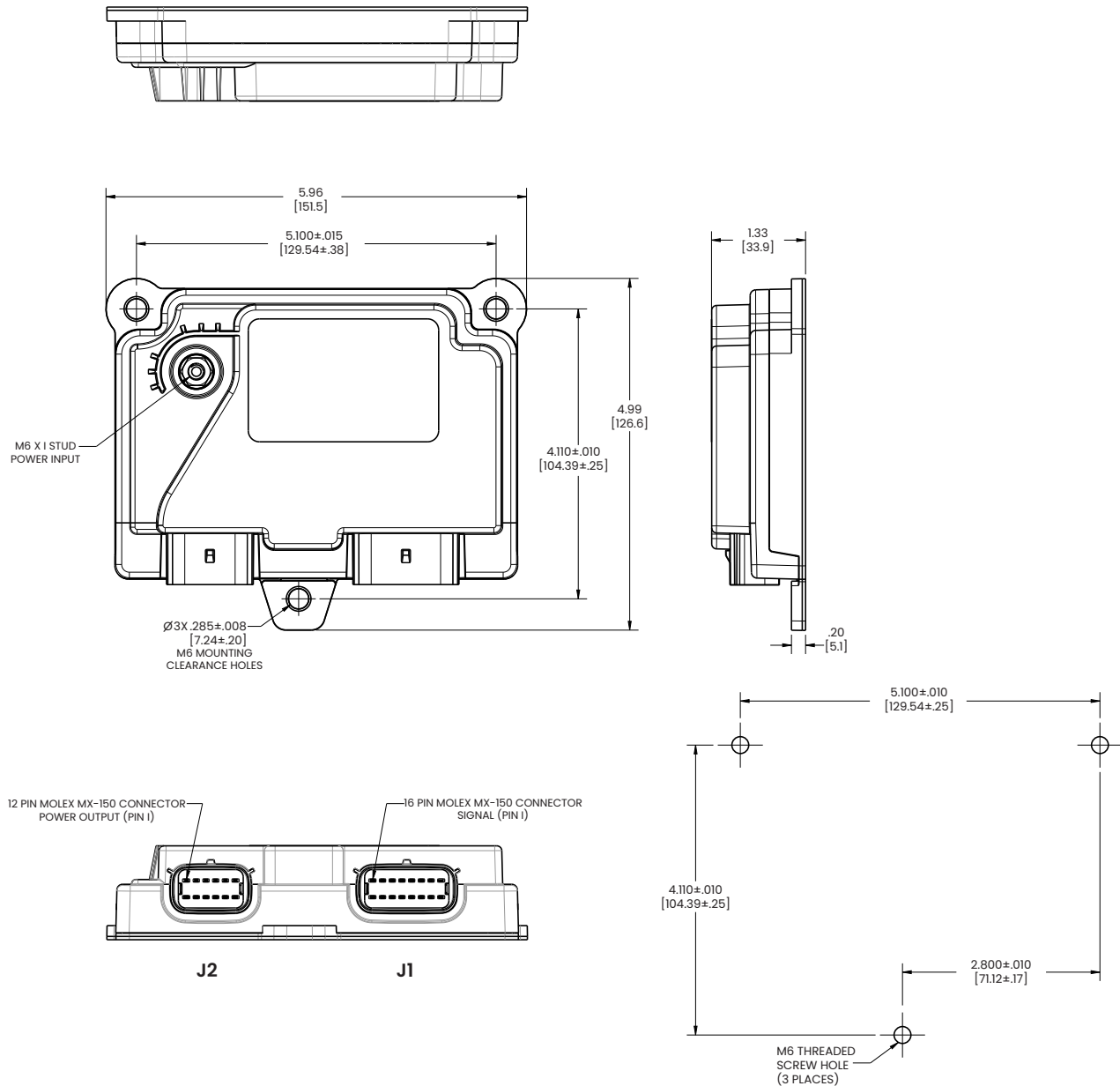

Connector Pin Out

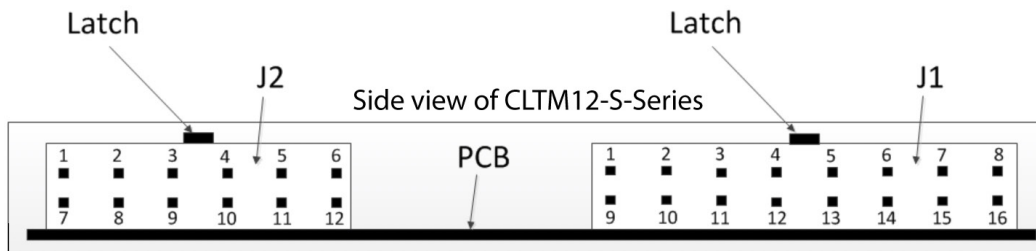

| J2 Connector Pin No. | Description | Output Rating in AMPS |
|----------------------|-------------|-----------------------|
| 1 | Output 5 | 10 |
| 2 | Output 4 | 10 |
| 3 | Output 8 | 10 |
| 4 | Output 2 | 10 |
| 5 | Output 10 | 10 |
| 6 | Output 1 | 10 |
| 7 | Output 7 | 10 |
| 8 | Output 9 | 5 |
| 9 | Output 6 | 5 |
| 10 | Output 12 | 5 |
| 11 | Output 3 | 5 |
| 12 | Output 11 | 10 |

| J1 Connector Pin No. | Description |
|----------------------|--|
| 1 | CAN High |
| 2 | System Ground |
| 3 | Baud Rate Select |
| 4 | Address #1 (active low) |
| 5 | Digital Input #3 (active high / open) |
| 6 | Digital Input #1 (active high / open) |
| 7 | Discrete Input #3 (active high / open) |
| 8 | Discrete Input #1 (active high / open) |
| 9 | CAN Low |
| 10 | CAN Shield |
| 11 | No connect |
| 12 | Address #2 (active low) |
| 13 | Digital Input #4 (active high) / Ignition Wake (active high) |
| 14 | Digital Input #2 (active high / open) |
| 15 | Pull-Down to Ground (for configuration address daisy-chain) |
| 16 | Discrete Input #2 (active high / open) |

Configuration

Digital inputs

The digital inputs (IND_1, IND_2, IND_3, IND_4_WKE) sense the presence of two voltage level states: "Active High", and "Open" are compatible with standard 5v logic devices (E.g. when the input is at +5v it will be read as a logic '1' or "High". When the input is at 0v or GND it will be read as logic '0') The unused digital inputs can be left disconnected.

- Absolute limits -2.3 to 36V
- Input resistance: 1K Ohm
- Input pin voltage open circuit: 2.75V

Configuration

Thresholds

Open = 1.58 to 4.28V

High = 4.78V to 6.63V

These thresholds apply when the CLTM12-S is not in sleep mode.

The IND_4_WKE pin is a special case. When the CLTM12-S is in sleep mode this pin serves as a means of waking the CLTM12-S from sleep when a low to high logic transition is detected.

The logic levels associated with this function are:

Logic high for levels no less than 3.70 V

In the sleep state the open circuit voltage on this pin is between 3.0 and 3.3V, so it must be pulled high to cross the threshold and wake the CLTM12-S.

Digital Input Impedance Model

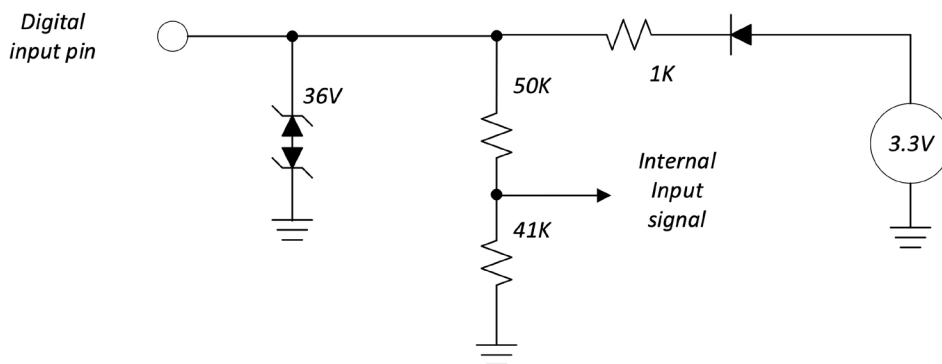

Discrete inputs

The discrete inputs (INA_1, INA_2, INA_3) are similar to the digital inputs in that they respond to two voltage level states "Active High", and "Open" (E.g. when the input is at V-Battery it will be read as a logic '1' or "High". When the input is at 0v or GND it will be read as logic '0') The unused discrete inputs can be left disconnected which results in an "open" state.

Absolute limits: -2.3 to 36V

Input resistance: 1K Ohm

Input voltage, open circuit: 2.75V

Thresholds:

Open = 1.51 to 4.31V

High = 4.82V to 32.0V

These thresholds apply when the CLTM12-S is not in sleep mode.

Configuration

Discrete Input Impedance Model

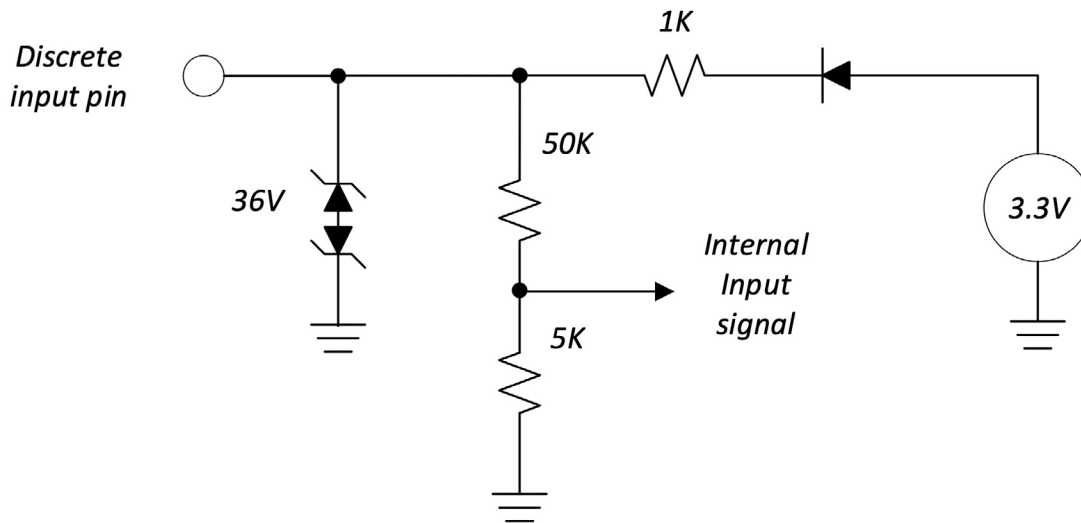

Address and Baud Rate select inputs

The address lines (ADD_1, ADD_2 and baud rate select) are active Low inputs that the software uses to identify the application based on the configuration of the wiring harness. These pins recognize two states Low and High.

| Address 1 | Address 2 | J1939 Source Address |
|-----------|-----------|----------------------|
| Open | Open | 49 (0x31) |
| Ground | Open | 50 (0x32) |
| Open | Ground | 51 (0x33) |

Open circuit voltage = 3.3V
Input resistance > 50K Ohms
Low = below 0.72V
High = above 1.65V

Baud Rate Select input

No connect (J1-3) for 250 Kbits/second select.
Connect (J1-3 to J1-15) for 500 Kbits/second select.
If the CLTM12-S-Series is configured for 500k Baud operation, several CAN errors will be visible on the bus at power-up. This is because the bootloader software is hard-configured for 250k Baud operation and will generate CAN errors as the software transitions from the bootloader to the application.

Configuration

Address & Baud Rate select Input Impedance Model

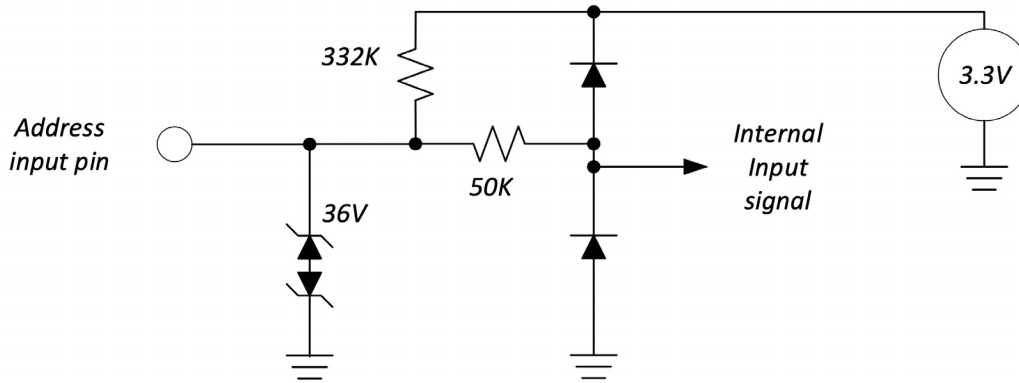

Output Channels

The 12 High side output channels are switched with MOSFETs connected in a back-to-back arrangement so that back-feeding is not possible when the channel is turned off.

| | |
|-----|--|
| 5A | Channels 3 (J2 pin 11), 6 (J2 pin 9), 9 (J2 pin 8) and 12 (J2 pin 10) |
| 10A | Channels 1 (J2 pin 6), 2 (J2 pin 4), 4 (J2 pin 2), 5 (J2 pin 1), 7 (J2 pin 7), 8 (J2 pin 3), 10 (J2 pin 5), 11 (J2 pin 12) |

The total current supplied by the CLTM12-S is limited to 75A.

All channels employ the following:

- Load Presence Detection
- Latched shutdown overcurrent detection with reset.
- Overcurrent surge allowance that prevents overcurrent latch tripping when starting high surge loads such as incandescent lamps.

Output Channel Schematic

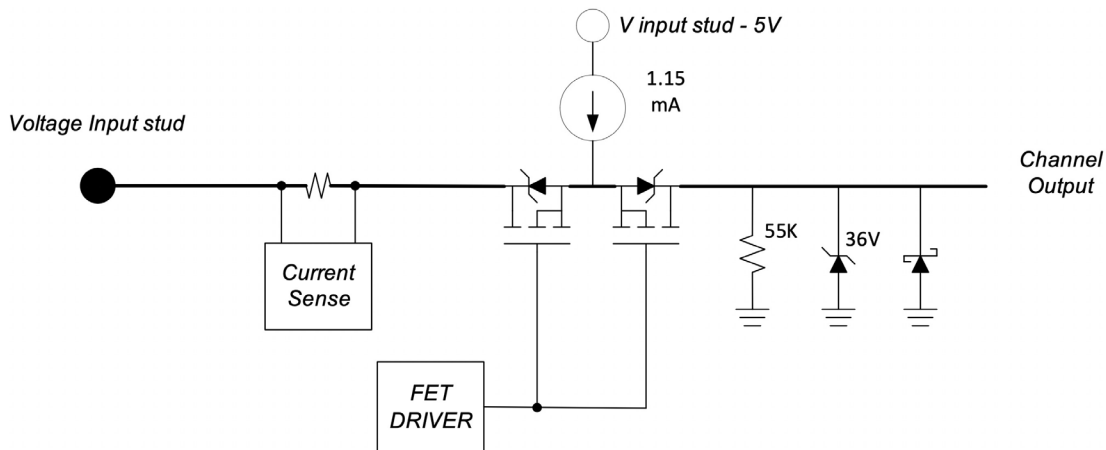

Configuration

Output Channel Schematic (continued)

When a channel is off, a current source supplies 1.15 mA to the load so that the channel output voltage can be used to determine its status. The real-time monitoring functions for the faults: "Open circuit" and "ON when commanded OFF" are implemented by comparing channel voltage to input voltage. "Open circuit" is asserted when the channel is OFF and the difference between the Input voltage and the Channel voltage is between 1.5V and 6.0 volts. If the difference between the Input and Channel voltages is between 0 and 1.5V when the channel is OFF, the "ON when commanded OFF" fault is asserted.

The OFF when commanded ON fault is asserted when a channel is ON and the channel voltage is 1.5V or less.

When an overcurrent condition is detected the hardware will latch the channel off and prevent it from being turned back on for the remainder of the continuously powered interval. The channel will be available again after a power cycle.

The surge allowance function is also implemented in hardware. Constant over-current levels are allowed for a time that is inversely proportional to the magnitude of overcurrent according to the following curve.

Most real loads have current draws that vary continuously with time for an interval of time. An incandescent lamp filament is an example where the instantaneous start current is a high peak that exponentially decays to the steady state level within a short time (100mS).

The surge allowance function does have a hard-peak limit that is not time dependent. The channel shuts down immediately when this limit is exceeded. The hard peak is greater than nine times (9x) the continuous current limit.

| | | |
|--------------------------|------|------|
| Channel current rating | 5A | 10A |
| Peak Current Limit | 70A | 140A |
| Continuous Current Limit | 7.5A | 15A |

Channel Current in Amperes vs. time to Overcurrent Shutdown in Seconds

