

PC-Series

Equipment Leakage Circuit Interrupters

PRODUCT WEBPAGE

request sample, configure part

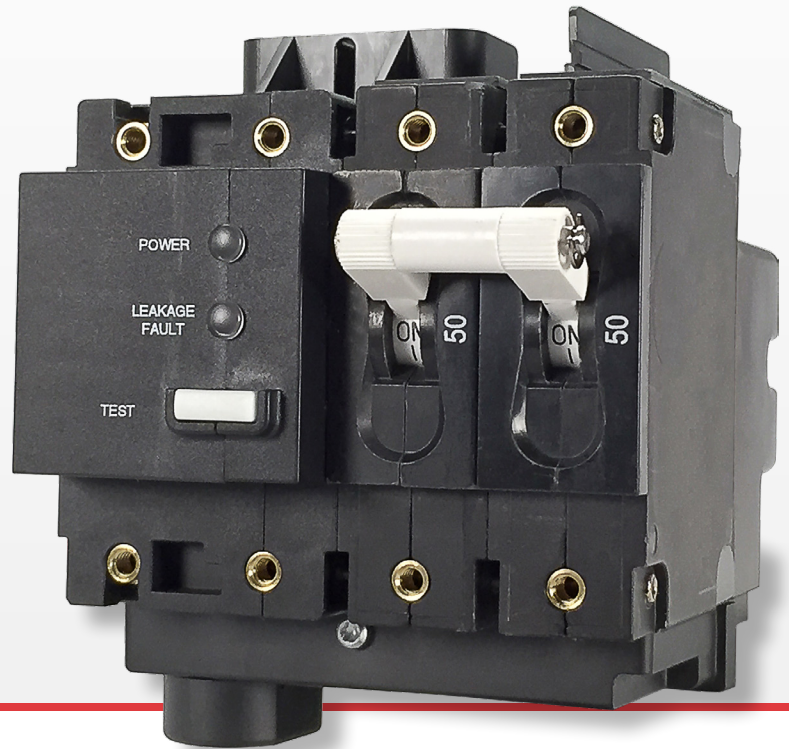

The PC-Series, AC Residual Current Circuit Breaker with Overcurrent Protection (RCBO), combines ground fault protection with the familiar overcurrent tripping characteristics of a normal circuit breaker to protect against low-level faults when installed near water. Based on the principles of hydraulic-magnetic design, the breaker also operates reliably when exposed to extreme heat or cold. This breaker series is available in one to three pole configurations and rated from .10-50 amps, 120VAC, 120/240VAC with max IC of 5,000 amps

1-3 Poles **0.10-50** Amps **120/240** VAC **5,000A Max** Interrupting Capacity



Typical Applications

- Marine
- Battery Chargers
- AC Water Heaters
- AC Main Ground Fault Protection for a boat's entire AC electrical system

Tech Specs

Electrical

Current Ratings	50 Amps maximum
Voltage Ratings	120 VAC, 120/240 VAC
Dielectric Strength	1480 VAC, 60Hz for 1 minute between all electrically isolated terminals
Insulation Resistance	Minimum of 100 Megohms at 500VDC
Leakage Current Trip Time	≤ 25 ms
EMI	UL 943 / IEC 61000-4-6, 0.5V 150KHz ~ 230 MHz
Operating Frequency	50/60 Hz
Reverse Polarity	A reversed Line / Load connection to the circuit breaker shall not cause damage to the device
Grounded Neutral	When neutral is grounded on load side of circuit
Overload	50 operations @ 600% of rated current on Breakers
Switched Neutral	2nd Pole on 120V and 3rd Pole on 120/240V, Optional
Manual Test	To be performed at least every month by pressing the test button on the ELCI to verify the device's ability to respond and trip when subjected to simulated leakage. Current imbalance is sufficient to cause tripping at 85% of rated voltage. Line Power at LI is required.

Impedance (Across Circuit breaker only)

RESISTANCE, IMPEDANCE VALUES
from Line to Load Terminals
(Values Based on Series Trip Circuit Breaker)

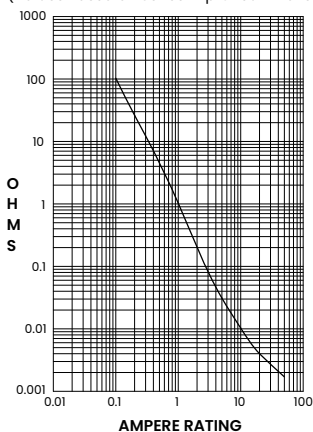

CURRENT (AMPS)	TOLERANCE (%)
0.10 - 5.0	± 15
5.10 - 20.0	± 25
20.10 - 50.0	± 35

Physical

Number of Poles	1-pole (1 Circuit Breaker + 1 ELCI Sensor Module), 120V. 2-pole (2 Circuit Breakers + 1 ELCI Sensor Module), 120/240V or 120V with Switched Neutral. 3-pole (3 Circuit Breakers + 1 ELCI Sensor Module), 120/240V with Switched Neutral.
Termination	Circuit Breaker Line Side: #10-32 ELCI Sensor Module Load Side: #10-32. Neutral pigtail provided with non-switched neutral units.
Mounting	Front Panel, #6-32 or M3 threaded inserts.
Actuator	Handle, Flat Rocker, Curved Rocker (with or without rocker guard), Push-to-Reset Rocker
Internal Circuit Config.	Circuit Breaker, Series Trip Switch only (without over-current protection)
Weight	1-pole: approx. 300 grams (10.6 ounces). 2-pole: approx. 375 grams (13.2 ounces) 3-pole: approx. 500 grams (17.6 ounces)
Standard Colors	Housing – Black, Test Button – White, Text – White

Environmental

Designed and tested in accordance with requirements of specification MIL-PRF- 55629 and MIL-STD-202G as follows:

Shock	Withstands 100 G, 6ms, sawtooth at rated current per Method 213, Test Condition "I".
Thermal Shock	Method 107D, Condition A (5-cycle at -55°C to +25°C to +85°C to +25°C)
Vibration	Withstands 0.06" excursion from 10-55 Hz, and 10 G 55-500 Hz, at rated current per Method 204C, Test Condition A. Instantaneous & ultrashort curves tested at 90% of rated current.
Moisture Resistance	93% RH at 30°C for 168 Hours.
Operating Temperature	-35°C to +66°C
Corrosion	3 weeks Humidity: 30±2%, 70±2% relative humidity Mixed Flowing Gases: 100 ppb H ₂ S, 20 ppb Cl ₂ , 200±50 ppb NO ₂

Mechanical

Endurance	10,000 "On-Off" Operations at 6 per minute; 6000 with Rated Current & Voltage (3000 test button and 3000 manual operations) and 4000 on/off operations with no load.
Trip Free	Trips on short circuit, overload or leakage to ground, even when actuator is forcibly held in the "On" position

Tech Specs

Agency Approvals

UL 1053	Ground Fault Sensing and Relaying Equipment
UL 1500	Ignition Protection

Tables

Table A: UL Recognized as an Equipment Leakage Circuit Interruptor - 120 and 120/240V

UL Recognized Configurations as an Equipment Leakage Circuit Interruptor							
Circuit Configuration	Voltage			Current Rating (Amps)	Short Circuit Capacity (Amps)	Ground Fault Trip Level (Milliamps)	Construction Notes
	Max Rating	Frequency (Hertz)	Phase				
Series	120	50 / 60	1	1 - 50	5000	30	1 or 2 Poles. One pole of a two pole unit must be Neutral
	120 / 240						2 or 3 Poles. One pole of a three pole unit must be Neutral
Series Ignition Protection	120	50 / 60	1	1 - 50	3000	30	1 or 2 Poles. One pole of a two pole unit must be Neutral
	120 / 240				5000		2 or 3 Poles. One pole of a three pole unit must be Neutral

Table B: UL Recognized as an Equipment Leakage Circuit Interruptor - 240V

UL Recognized Configurations as an Equipment Leakage Circuit Interruptor - 240V							
Circuit Configuration	Voltage			Current Rating (Amps)	Short Circuit Capacity (Amps)	Ground Fault Trip Level (Milliamps)	Construction Notes
	Max Rating	Frequency (Hertz)	Phase				
Series	240	50 / 60	1	1 - 30	5000	30	2 or 3 Poles. One pole of a three pole unit must be Neutral. Suffix 11
Series Ignition Protection				1 - 50	3000		2 or 3 Poles. One pole of a three pole unit must be Neutral. Suffix 12

ELCI Test Instructions

1. Turn "OFF" the Breaker actuator. Turn on the power to the panel. The green and red LED's should be off.
2. Turn "ON" the Breaker actuator. The green "POWER" LED should show steady illumination and the red "LEAKAGE FAULT" LED should flash every 3 seconds to indicate a successful self-test.
3. Depress the "TEST" button. This will cause the actuator to move to the "OFF" position and the red LED to turn on and show steady illumination, indicating that the ELCI is functioning properly. The green LED will also go from steady to off. If the actuator fails to move to the "OFF" position or the red LED fails to illuminate, the unit MUST be replaced.
4. Turn the Breaker actuator to the "ON" position. The green LED should flash every 3 seconds and the Red LED should show be off.
5. This test is to be performed on a monthly basis and recorded on the "Monthly Test Reminder" label.

ELCI LED Indication

Indicator - Two integrated LEDs, Red & Green

1. Green LED On, Red LED Off - Line Voltage is present, the breaker is closed, and the device is protecting the circuits against over current and leakage current.
2. Green LED Off, Red LED On - The device has detected leakage current and has opened the circuit breaker.
3. Green LED Flashing, Red LED Off - The circuit breaker has opened due to over current or has been turned off manually
4. Green LED Off, Red LED Off - Line Voltage is not present
5. Green LED Flashing, Red LED Off, Amber LED ON - Indicates Hot & Neutral are reversed and the circuit breaker is open

Neutral Protection - When neutral is grounded on load side of circuit

Test Button - Located on Ground Fault Module

Ordering Scheme

Sample Part Number

PC B - B A - 24-620 - 1 B A - E 11

Selection

1 2 3 4 5 6 7 8 9 10 11

1. SERIES

PC

2. SYSTEM VOLTAGE / POLES

- A 120 VAC single phase, 1 pole
- B 120/240 VAC single phase, 2 pole
- C 120/240 VAC single phase with switched neutral, 3 pole
- D 120 VAC single phase with switched neutral, 2 pole
- G 240 VAC single phase, 2 pole

3. CIRCUIT

- B Series Trip (Current)

4. ACTUATOR

- | | |
|-------------------------------------|-----------------------------------|
| Handle | Single Color Curved Rocker |
| A 1 per breaker pole | Push-to-Reset |
| B 1 per unit | R Vertical legend |
| Two Color Curved Visi-Rocker | U Horizontal legend |
| C Indicate ON, vertical legend | Two Color Flat Visi-Rocker |
| D Indicate ON, horizontal legend | 1 Indicate OFF, vertical legend |
| F Indicate OFF, vertical legend | 2 Indicate OFF, horizontal legend |
| G Indicate OFF, horizontal legend | Single Color Flat Rocker |
| Single Color Curved Rocker | 3 Vertical legend |
| J Vertical legend | 4 Horizontal legend |
| K Horizontal legend | Two Color Flat Visi-Rocker |
| Two Color Curved Visi-Rocker | Push-to-Reset |
| Push-to-Reset | 5 Indicate OFF, vertical legend |
| N Indicate OFF, Vertical legend | 6 Indicate OFF, horizontal legend |
| O Indicate OFF, Horizontal legend | Single Color Flat Rocker |
| | Push-to-Reset |
| | 7 Vertical legend |
| | 8 Horizontal legend |

ROCKER STYLE DESCRIPTIONS					
	INDICATE "ON"	INDICATE "OFF"	SINGLE COLOR	INDICATE "OFF"	SINGLE COLOR
VERTICAL STYLE	CODE "C" 	CODE "1", "N" 	CODE "J", "R" 	CODE "1", "5" 	CODE "3", "7"
	INDICATE LOCATION 		INDICATE LOCATION 		
HORIZONTAL STYLE	CODE "D" 	CODE "G", "O" 	CODE "K", "U" 	CODE "2", "6" 	CODE "4", "8"
	INDICATE LOCATION 		INDICATE LOCATION 		

5. FREQUENCY & DELAY

- 20 50 / 60Hz Instantaneous
- 21 50 / 60Hz Ultra Short
- 22 50 / 60Hz Short
- 24 50 / 60Hz Medium
- 26 50 / 60Hz Long

6. CURRENT RATING (AMPERES)

CODE	AMPERES	CODE	AMPERES	CODE	AMPERES	CODE	AMPERES
410	1.00	445	4.50	610	10.00	618	18.00
512	1.25	450	5.00	710	10.50	620	20.00
415	1.50	455	5.50	611	11.00	622	22.00
517	1.75	460	6.00	711	11.50	624	24.00
420	2.00	465	6.50	612	12.00	625	25.00
522	2.25	470	7.00	712	12.50	630	30.00
425	2.50	475	7.50	613	13.00	635	35.00
527	2.75	480	8.00	614	14.00	640	40.00
430	3.00	485	8.50	615	15.00	650	50.00
435	3.50	490	9.00	616	16.00		
440	4.00	495	9.50	617	17.00		

7. TERMINAL

- 1 Stud, 10-32 threaded

8. ACTUATOR COLOR & LEGEND

Handle Actuator Color	I-O	ON-OFF	Dual	Rocker Actuator Color	Single	Visi-Rocker
White	A	B	1	Black	Black	White
Black	C	D	2	White	White	N/A
Red	F	G	3	White	White	Red
Green	H	J	4	White	White	Green
Blue	K	L	5	White	White	Blue
Yellow	M	N	6	Black	Black	Yellow
Gray	P	Q	7	Black	Black	Gray
Orange	R	S	8	Black	Black	Orange

9. MOUNTING / BARRIERS

MOUNTING STYLE	BARRIERS
Threaded Insert, 2 per pole	
A 6-32 X 0.195 inches	yes
B ISO M3 x 5mm	yes
Rockerguard Bezel	
Threaded Insert, 2 per pole	
C 6-32 X 0.195 inches	yes
D ISO M3 x 5mm	yes
Standard Bezel with Recessed Off-Side Flat Rocker	
Threaded Insert, 2 per pole	
E 6-32 X 0.195 inches	yes
F ISO M3 x 5mm	yes
Push-to-Reset Bezel	
Threaded Insert, 2 per pole	
G 6-32 X 0.195 inches	yes
H ISO M3 x 5mm	yes

10. LEAKAGE CURRENT TRIP LEVEL - MAX. TRIP CURRENT

- E 30 MA (ELCI) ¹

11. AGENCY APPROVAL

- AA without Approvals
- 11 30 mA: UL 1053 Recognized Component, CSA Recognized Component with UL Listed Circuit Breakers ¹
- 12 30 mA: UL 1053 Recognized Component, CSA Recognized Component with UL 1077 Supplementary Protectors with UL 1500 Ignition Protection ¹

Notes:

- 1 This device meets the requirements of ABCY EII.

[Configure Complete Part Number >](#)

[Browse Standard Parts >](#)

Dimensional Specs

inches [millimeters]

INDICATE OFF / SINGLE COLOR
ROCKER ACTUATOR

HANDLE / INDICATE ON
ROCKER ACTUATOR

TERMINAL
LOCATIONS

PCA
120 VAC
VERSION

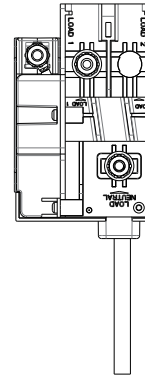
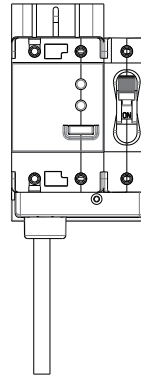
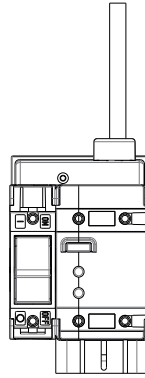

PCB
120/240 VAC
VERSION

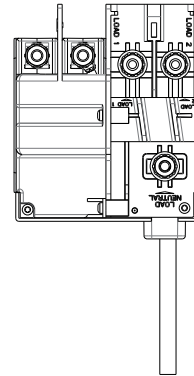
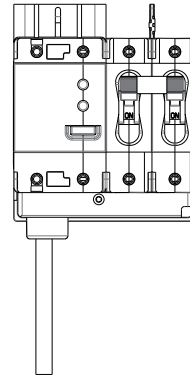
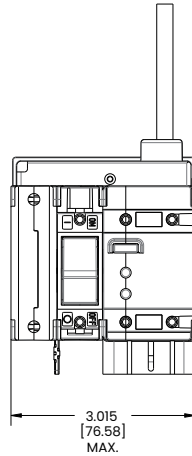

PCC
120/240 VAC
VERSION
W/ NEUTRAL BREAK

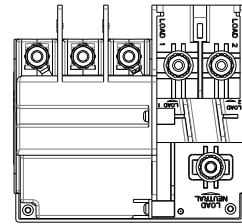
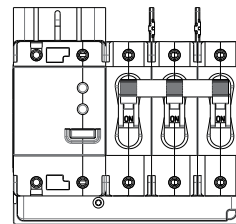
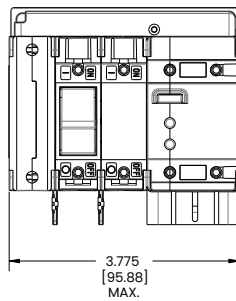

PCD
120 VAC
VERSION
W/NEUTRAL BREAK

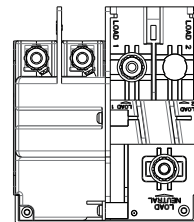
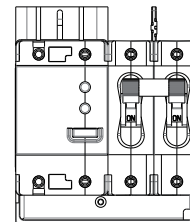
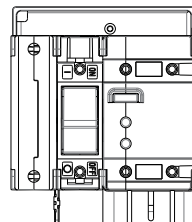

Dimensional Specs

inches [millimeters]

NOTE: NEUTRAL - SUPPLIED 12" LONG MIN. (CIRCUIT CODES A,B,E & F)

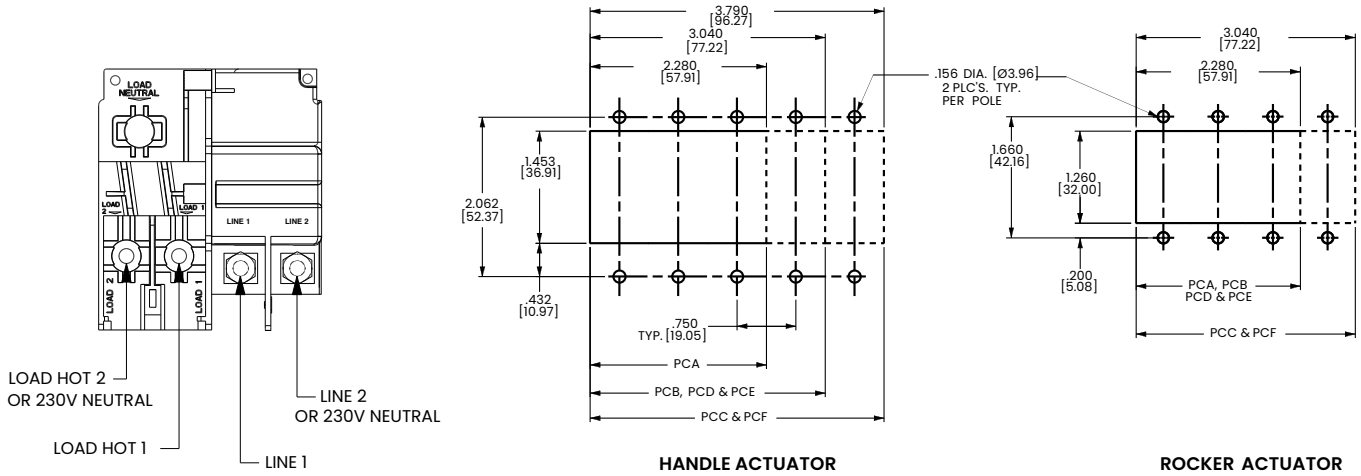

PANEL CUTOUT DETAIL

TOLERANCES ±.005[.12]

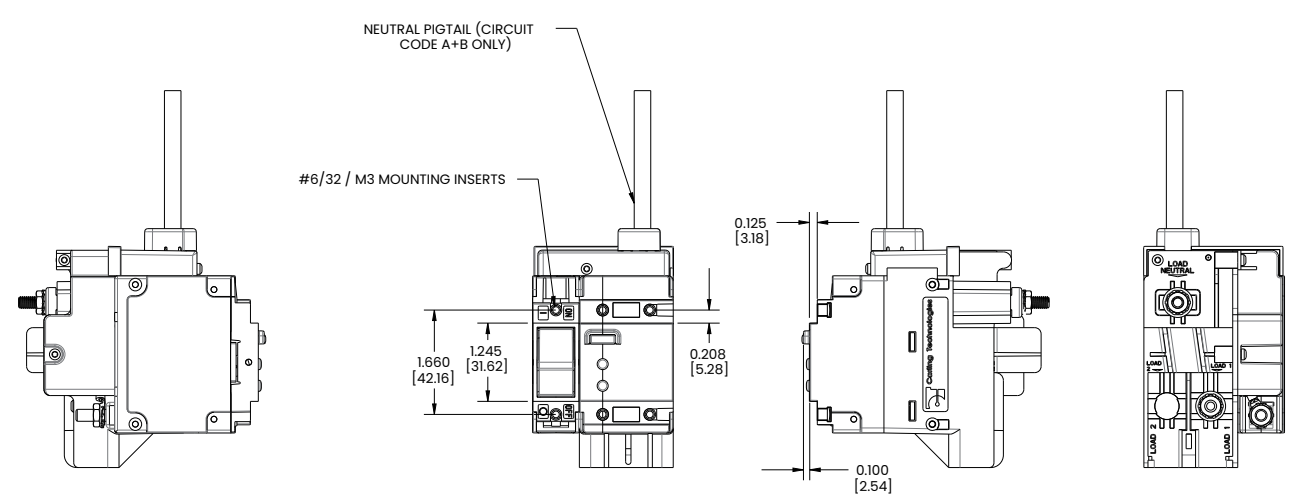
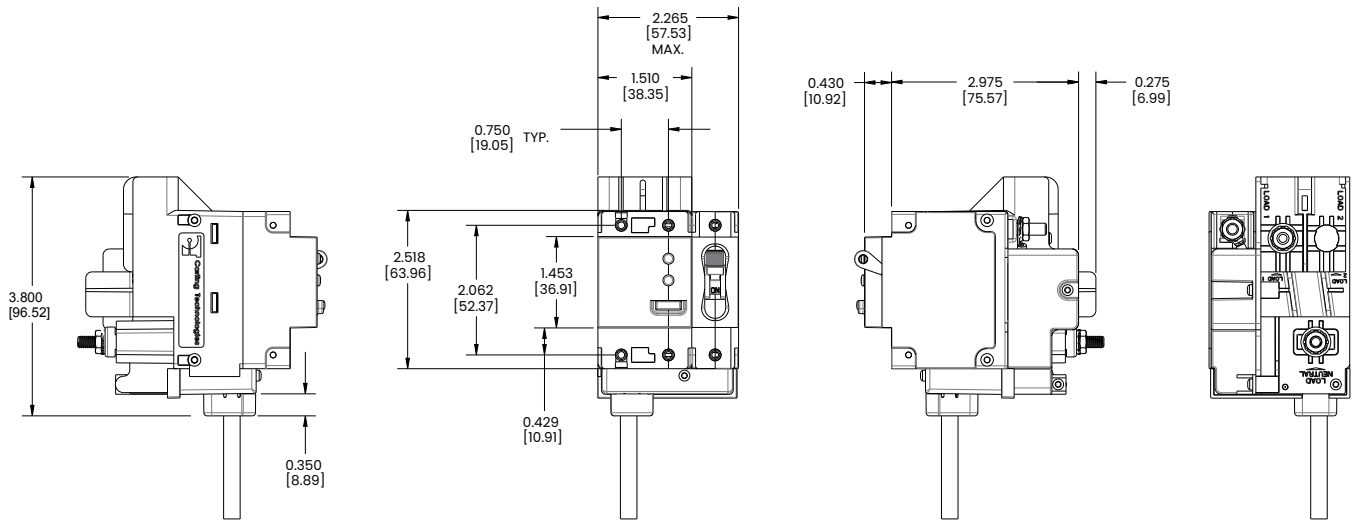

Notes:
For additional circuit breaker dimensions, reference the C-Series Breakers in the Carling Circuit Protection catalog

Ordering Scheme

Sample Part Number 8 PC - 1 3 1

Selection 1 2 3 4 5

1. TYPE NUMBER

8 Circuit Breaker Assembly

2. SERIES

PC

3. ACTUATOR TYPE

- 1 Handle, one per pole
- 2 Handle, one per multipole unit
- A Rocker

4. POLES PER UNIT - INCLUDING ELECTRONIC MODULE

- 3 Three
- 5 Five

5. MOUNTING SCREWS / PLATE MATERIAL ¹

- 1 6-32 Thread Phillips Head
- 2 M-3 Thread Phillips Head
- 3 6-32 Thread Slotted Head
- 4 M-3 Thread Slotted Head
- 5 6-32 Thread Phillips Head with Stainless Steel Plate
- 6 M-3 Thread Phillips Head with Stainless Steel Plate
- 7 6-32 Thread Slotted Head with Stainless Steel Plate
- 8 M-3 Thread Slotted Head with Stainless Steel Plate

Notes:

- 1 Screws supplied to accommodate mounting panel thickness of $1/8" \pm 1/32"$. Consult Factory for additional options
- 2 Available for Flat and Curved Rocker options - No Rockerguard Bracket

Handle Style Panel Seal

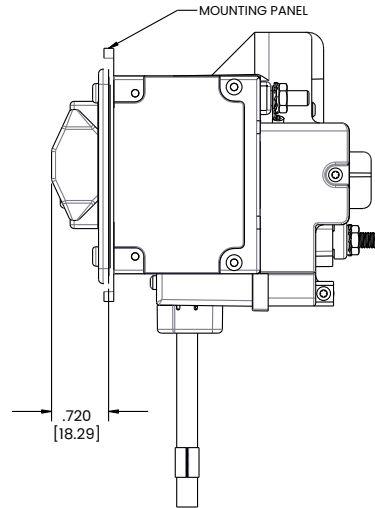
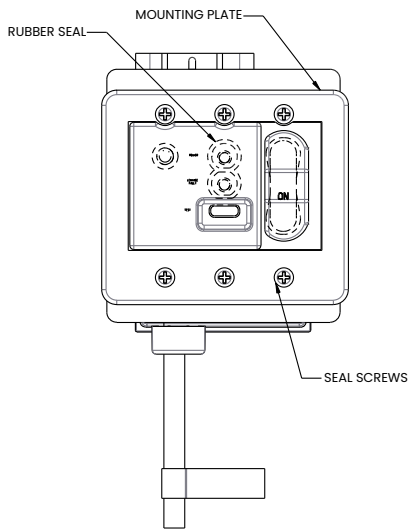

Rocker Style Panel Seal

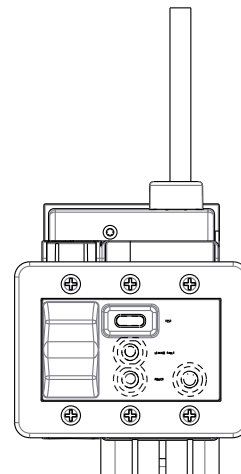
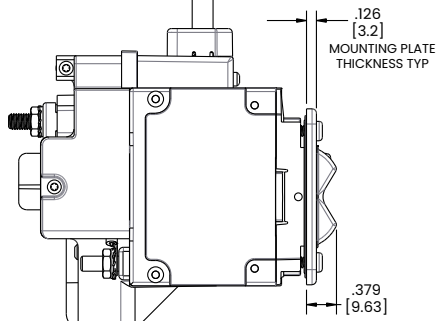

Dimensional Specs

Handle Actuator

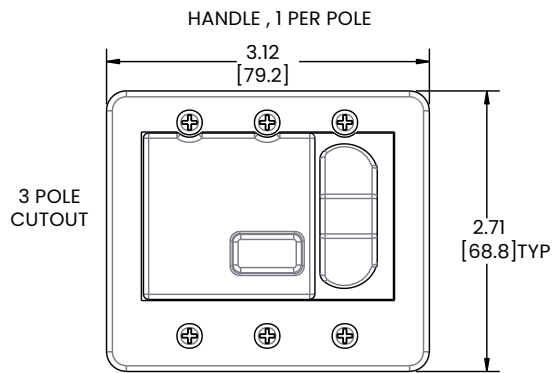

8PC-13

HANDLE, 1 PER MULTIPOLE UNIT

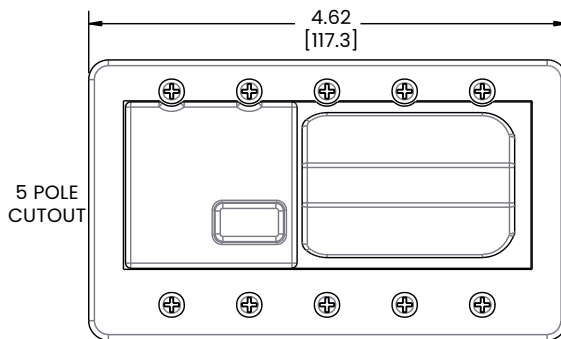

8PC-15

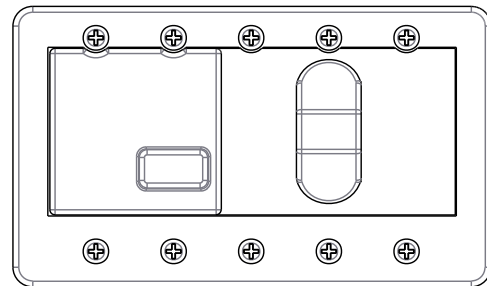

8PC-25

Rocker Actuator

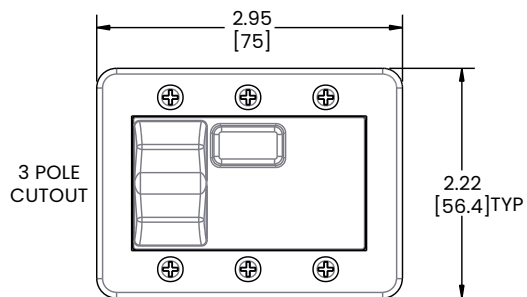

8PC-A3

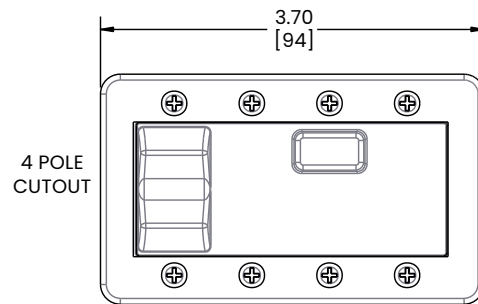

8PC-A4

Time Delay

Instantaneous

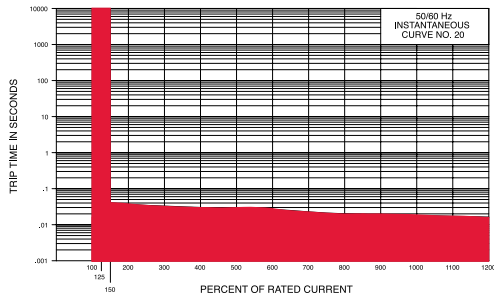

Medium

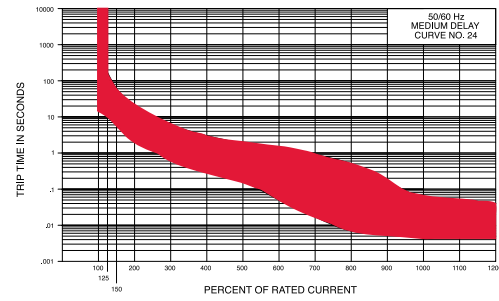

Ultra Short

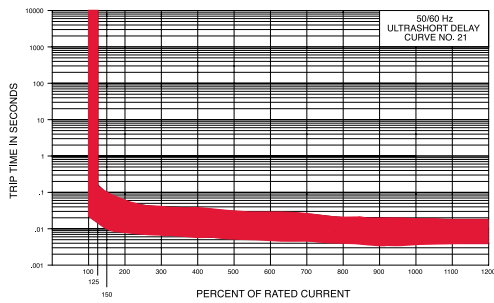

Long

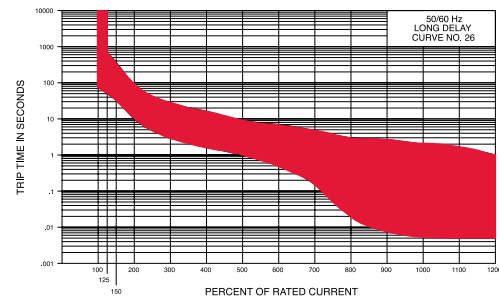

Short

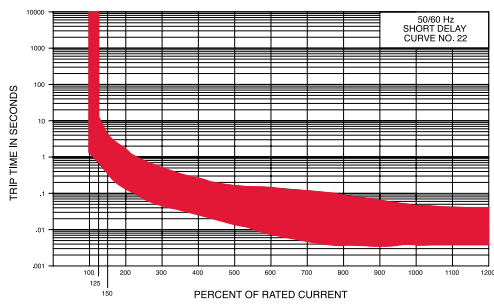

Time Delay Values									
Percent of Rated Current									
Delay	100%	125%	150%	200%	400%	600%	800%	1000%	1200%
20	No Trip	May Trip	.040 MAX	.035 MAX	.030 MAX	.025 MAX	.020 MAX	.017 MAX	.015 MAX
21	No Trip	.014 - .150	.011 - .095	.008 - .055	.006 - .035	.005 - .027	.005 - .021	.004 - .018	.004 - .017
22	No Trip	.700 - 12.0	.350 - 4.00	.130 - 1.30	.027 - .220	.008 - .130	.004 - .090	.004 - .045	.004 - .040
24	No Trip	10.0 - 160	6.00 - 60.0	2.20 - 20.0	3.00 - 3.00	.050 - 1.30	.007 - 5.00	.005 - 0.60	.005 - .040
26	No Trip	50.0 - 700	32.0 - 350	10.0 - 90.0	1.50 - 15.0	.500 - 7.00	.020 - 3.00	.006 - 2.00	.005 - 1.00

Notes:

Other time delay values available, consult factory.

Delay Curves 21,22,24,26: Breakers to hold 100% and must trip at 125% of rated current and greater within the time limit shown in this curve.

Delay Curve 20: Breakers to hold 100% and must trip at 150% of rated current and greater within the time limit shown in this curve.

All Curves: Curve data shown represents breaker response at ambient temperature of 77°F (25°C) with no preloading. Breakers are mounted in standard wall-mount position.

The minimum inrush pulse tolerance handling capability is 12 times the rated current. These values are based on a 60 Hz 1/2 cycle, 8.33 ms pulse.