

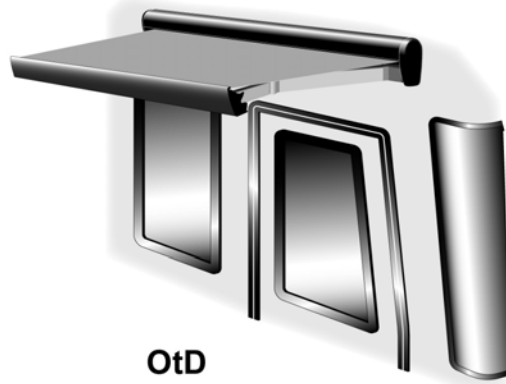

RV



WINDOW



OtD

TABLE OF CONTENTS

Product Overview 3
 Component Checklist.....3

Installation 4
 Installation Using an Awning Rail4

Electrical 5
 Standard Switch Installation5
 Wiring the Connector.....5
 Installer Furnished Switches.....6
 Alternate Switch A6
 Alternate Switch B6
 Setting the Motor Limits7
 Optional Factory Installed LED (OEM)8
 Switch Installation.....8

PROPRIETARY STATEMENT

The Marquee Window and OtD Awnings are products of Carefree of Colorado, located in Broomfield, Colorado, USA. The information contained in or disclosed in this document is considered proprietary to Carefree of Colorado. Every effort has been made to ensure that the information presented in the document is accurate and complete. However, Carefree of Colorado assumes no liability for errors or for any damages that result from the use of this document.

The information contained in this manual pertains to the current configuration of the models listed on the title page. Earlier model configurations may differ from the information given. Carefree of Colorado reserves the right to cancel, change, alter or add any parts and assemblies, described in this manual, without prior notice.

Carefree of Colorado agrees to allow the reproduction of this document for use with Carefree of Colorado products only. Any other reproduction or translation of this document in whole or part is strictly prohibited without prior written approval from Carefree of Colorado.

SAFETY INFORMATION

WARNING

A WARNING INDICATES A POTENTIALLY HAZARDOUS SITUATION WHICH, IF NOT AVOIDED, COULD RESULT IN DEATH OR SERIOUS INJURY AND/OR MAJOR PROPERTY DAMAGE.

CAUTION

A CAUTION INDICATES A POTENTIALLY HAZARDOUS SITUATION THAT MAY CAUSE MINOR TO MODERATE PERSONAL INJURY AND/OR PROPERTY DAMAGE. IT MAY ALSO BE USED TO ALERT AGAINST UNSAFE PRACTICES.

NOTE: A note indicates further information about a product, part, or step.

Tip: A tip provides helpful suggestions.

Safety Notes:

- Always disconnect battery or power source before working on or around the electrical system.
- Always wear appropriate safety equipment (i.e. goggles).
- Always use appropriate lifting devices and/or helpers when lifting or holding heavy objects.
- When using fasteners, use care to not over tighten. Soft materials such as fiberglass and aluminum can be "stripped out" and lose the ability to grip and hold.

Reference Publications located @ www.carefreeofcolorado.com

052549-001 Marquee Installation Manual

052549-201 Marquee Owner's Manual

052549-301 Marquee Service Manual

PRODUCT OVERVIEW

The Marquee Window and OtD (Over the Door) Awnings are state of the art lateral arm awnings. When retracted, the housing provides protection against the elements while the streamlined styling blends in with the coach side wall. The full tension canopy fabric allows the awning to be partially or fully extended for best shade coverage. No vertical arms interfere with coach sidewalls, custom graphics or equipment that may be mounted on the sidewalls.

Awning Specifications:

- Fully retractable and self storing;
- The sealed awning motor operates on standard 12VDC (range 10VDC to 14VDC);
- Fabric is woven acrylic;
- Case and frame are constructed of high-strength aluminum extrusions, protected with a polyester paint finish;

EXTENSION: 36"	AVAILABLE WIDTHS:	<i>OtD</i>	50", 54",60", 66", 72"
		<i>Window</i>	50", 54",60", 66", 72", 7', 8', 9', 10' 11', 12' & 13'

LEADING EDGE POSITION ACTUATION AND CONTROL

<i>Power:</i>	Lateral Arm Spring	<i>Minimum Tension</i>	Open
<i>Position Control:</i>	<i>Motorized:</i>	Roll Out/In Controlled by Electrical Motor	
<i>Motor Type:</i>	Tubular		
<i>Power:</i>	12VDC	<i>Minimum:</i> 8VDC	<i>Output:</i> 30 Watts
	<i>Nominal Current:</i> 2.5Amps		<i>Max Current:</i> 14Amps (stall @ min voltage)
<i>Power Source:</i>	Motor and controls are routed and hardwired into the vehicle's 12V system		
<i>Torque</i>	<i>Continuous:</i> 6Nm/4.5 ft-lbs.		<i>Tightening:</i> 18Nm/13.2 ft-lbs.
<i>Speed</i>	15 rpm		
FABRIC:	Woven Acrylic Fabric (refer to sales literature for colors available)		

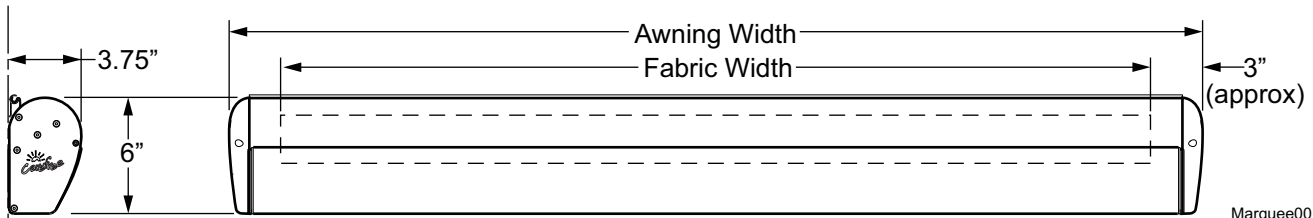

COMPONENT CHECKLIST

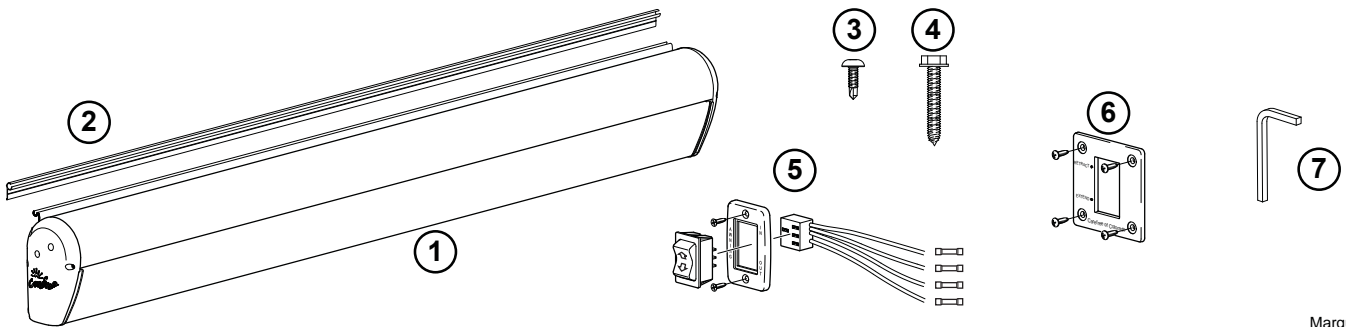

<input checked="" type="checkbox"/>	ITEM	DESCRIPTION		QTY	NOTE
<input type="checkbox"/>	1	Awning Assembly		1	1
<input type="checkbox"/>	2	Awning Rail		1	
<input type="checkbox"/>	3	Screw, Truss Head, Square Drive	#10 x 1	20	
<input type="checkbox"/>	4	Screw, Lag	1/4 x 1 1/2	3	
<input type="checkbox"/>	5	Switch Kit		1	
<input type="checkbox"/>	6	Switch Plate Kit, Square		1	2
<input type="checkbox"/>	7	Manual Override Key		1	3

- Notes:
1. Awning configuration is specified at time of order, including awning length, fabric, color etc.
 2. Square switch plate kit is optional and must be specified at time of order.
 3. Place override key (item 8) with RV owner information.

INSTALLATION

The awning is mounted using a standard awning rail.

If there is an awning rail installed, check that the awning rail runs the full length of the awning. The awning rail must be extremely straight to accommodate the awning mount. If a full length awning rail is installed, skip to step 6 below.

INSTALLATION USING AN AWNING RAIL

- Determine the optimum positioning of the awning.
 - The centerline of the awning fabric is offset from the centerline of the awning assembly. To align the center of the fabric, use the backplate of the awning assembly for measurements.
 - For OtD applications, set the center of the awning rail a minimum of 13" above the door. When installed, the bottom of the awning case is 5 7/8" from the centerline of the awning rail. The bottom of the case must be a minimum of 7" above the door.
 - For window applications, set the center of the awning rail a minimum of 7 1/2" above the window molding.
 - Measure each end of the rail position so that the rail will be mounted parallel to the ground.
- Mark the position with a chalk line.
- Coat the back of the rail with silicone sealant or putty tape.
- Align the awning rail onto the wall and secure with the truss head, square drive #10 x 3/4 screws. Use all the attach holes and ensure that the rail is securely mounted to the structural frame.
- Lightly coat the outside of the mounting rail of the awning case with a silicone lubricant or equivalent.
- Lift the awning up and tilt as shown.
- Hook the mounting rail of the awning into the awning rail and roll down.
- Adjust the position of the awning horizontally as required. It may be necessary to lightly lift the awning so that it will slide in the awning rail.
- Route the motor wires into the vehicle:
 - Lift the awning upward slightly. On the coach wall, mark the location of where the motor wires exit the awning case. If the location interferes with interior features, the location may be adjusted horizontally along the back of the case. The wires can be routed behind the case to hole.
 - Measure and drill one 3/8" hole through the outer wall at the mark.
 - Route the motor wires through the hole and seal with silicone sealant.
- Rotate the awning down.
- Open the awning. To open the awning, momentarily connect the motor wires to a 9-14VDC drill battery or car battery. If the motor runs in the reverse direction, reverse the leads.

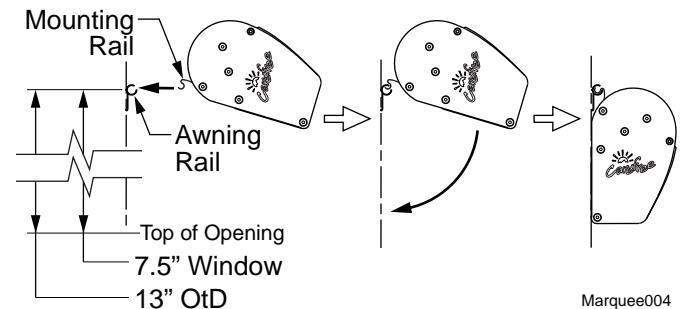

- (Refer to figure 4) Drill three (3) 3/16" holes through the back of the case into the mounting surface and into the structure. Use care to not drill through the inner wall.

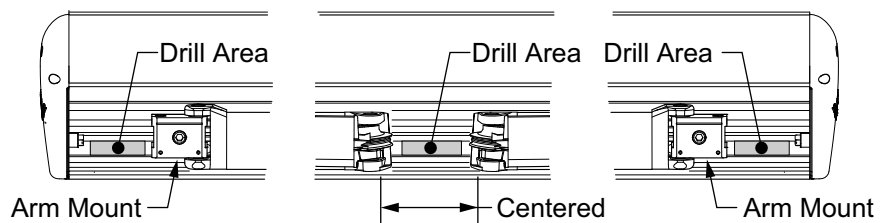

- Drill out the 3/16" holes in the awning case to 5/16". Do not allow the drill to extend into the wall.

⚠ CAUTION The screws must be located in the open areas of the awning case as shown. The arms cannot close completely if the screw heads are underneath.

- Secure the awning case to the RV using three (3) 1/4 x 1 1/2 lag screws.

ELECTRICAL

⚠ CAUTION Always disconnect the electrical sources before working with the electrical wiring.

STANDARD SWITCH INSTALLATION

The standard switch plate uses a rectangular hole to mount the switch. An optional square switch plate is available and is used when a round mounting hole is preferred or may be used for replacement of existing switches that used a round mounting hole.

1. Route the motor wires from the awning to the switch location. There is approximately 70" [180cm] of wire from the awning motor. If the distance to the switch exceeds the furnished wire, the installer must furnish 18 awg wire and butt splice to the motor wires.

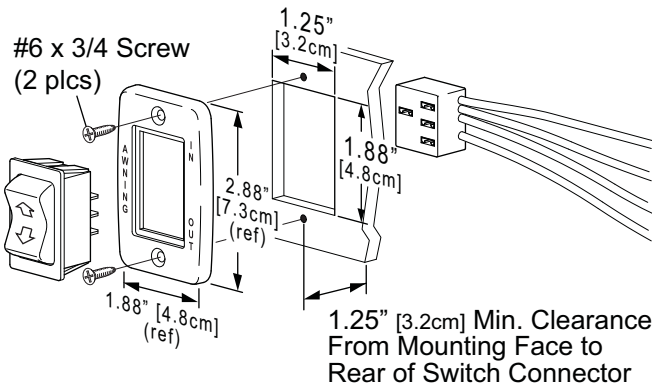

DETAIL A
Narrow Plate w/ Right Side Orientation

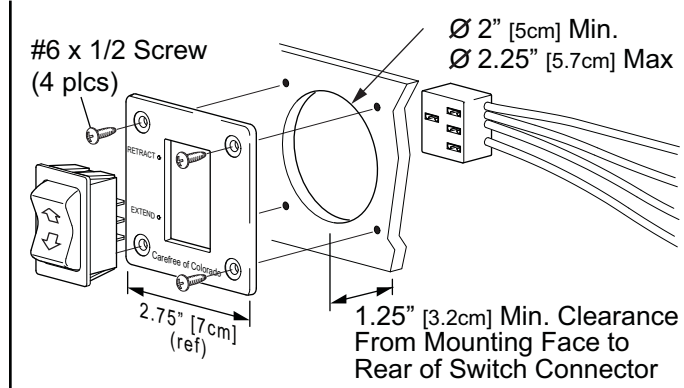

DETAIL B
Square Plate w/ Right Side Orientation

2. At the switch location:
 - 2.1. For a narrow switch plate (detail A), cut a rectangular hole 1.25"(3.2cm) x 1.88" (4.8cm) through the mounting surface.
 - 2.2. For a square switch plate (detail B), use a 2" (5cm) hole saw and cut a hole through the mounting surface.
3. Determine the switch orientation:
 - 3.1. The wires of the connector extend from the side of the switch with 3 terminals on the back.
 - 3.2. For wire routing on the right side of the switch as shown in Details A and B, orient the switch with the 3 terminals on the right.
 - 3.3. For wire routing on the left side of the switch as shown, orient the switch with the 3 terminals on the left.
 - 3.4. Push the switch into the faceplate until the tabs on the switch "click" into place behind the faceplate. Ensure that the switch and faceplate are oriented so that the lettering is up and the wires are oriented as desired.

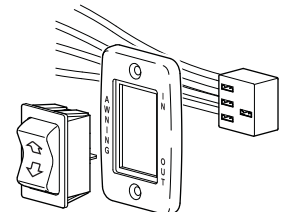

Example of Left Side Orientation SK002c

Wiring the Connector

1. Route the awning motor wires through the switch hole and splice to the switch connector:

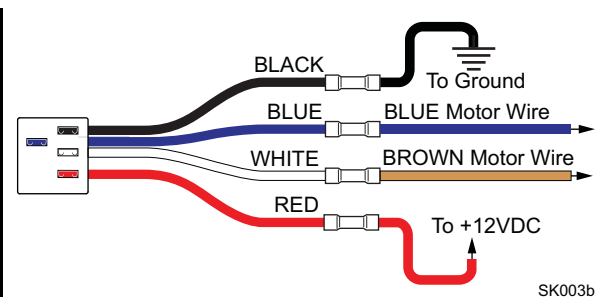
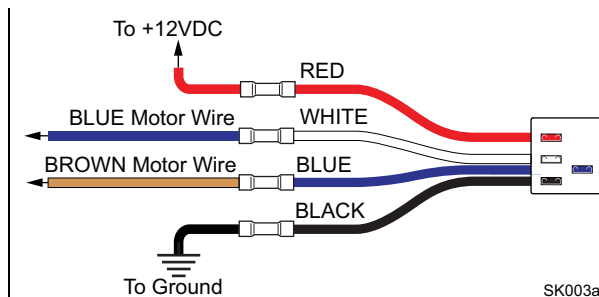

CONNECTOR WIRE COLOR	LH CONNECTOR ORIENTATION	RH CONNECTOR ORIENTATION
RED →	+12VDC	+12VDC
WHITE →	BLUE (motor wire)	BROWN (motor wire)
BLUE →	BROWN (motor wire)	BLUE (motor wire)
BLACK →	Ground	Ground

5. Run a minimum 14 awg wire from the power distribution panel (auxiliary battery circuit) or equivalent. The circuit should be protected by a 15-amp fuse.
6. Run a minimum 14 awg wire to system ground.

NOTE: If the wire run is 30 feet or longer, use 12awg wire to prevent voltage drop.

2. Route the two wires through the mounting hole. Butt splice the 12VDC wire to the RED connector wire. Butt splice the ground wire to the BLACK connector wire.
3. Attach the connector to the switch.
4. Restore power and test the switch operation.
5. If the awning operates opposite to the switch plate markings:
 - Shut off power;
 - Reverse motor wires connected to the blue and white connector wires;
 - Restore power and test.
6. Push the wires, connector and switch into the mounting hole and secure the switch plate.
 - For the narrow plate, use two (2) #6 x 3/4" flat head screws.
 - For the square plate, use four (4) #6 x 1/2" oval head screws.

INSTALLER FURNISHED SWITCHES

Two switch alternatives are available for installers wishing to furnish the control switch.

Alternate Switch A

The installer can use a double pole, double throw switch with momentary ON, center OFF (Momentary ON – OFF – Momentary ON). The switch MUST have polarity reversal between the two ON positions.

Alternate Switch B

Used with the Carefree relay module, the installer may use up to two (2) single pole switches. The switch(es) must be momentary on, single pole, double throw, center OFF (Momentary ON – OFF – Momentary ON).

1. Route a cable for the motor wires from the motor location through the carriage walls to the location of the switch/relay module. The recommended cable from the switch to the awning should be 2-conductor, 20AWG, stranded, PVC coated, unshielded wire.
2. Butt-splice the motor wires to the installer furnished cable wires. Match the wire colors.
3. Determine the location of the switch.
 - Location should provide the operator a view of the shade during operation.
 - Follow the switch manufacturer's directions for preparing the switch mount location.
 - The relay module must be mounted within 16" or less of the switch location.
4. Separate the wires from the relay module into 3 groups:
 - Brown, yellow and gray (primary switch),
 - Black and red (power leads),
 - Connector bundle with: Brown, yellow and gray (switch); and, Blue and white (motor).

NOTE: The relay module harness is supplied with one connector installed. The installer must furnish the mating connector (p/n 1-480704) and terminals (p/n 350547-3) for the exterior switch and motor cables. Vendor: AMP/Tyco Electronics.

5. Measure and cut away any excess cable from the motor and primary switch wires. Terminate the wires and install in the mating connector as shown.
4. Run a wire from chassis ground to the relay module. Suitable ground would be the vehicle chassis or conductive structure connected to the chassis. Butt splice to the black (ground) relay wire.
5. Run an 18 gauge wire from the power distribution panel (auxiliary battery circuit) or equivalent to the relay module. The circuit should be protected by a 5 amp fuse (the motor has a maximum 2 amp stall current). Butt splice to the red (+12VDC) relay wire.

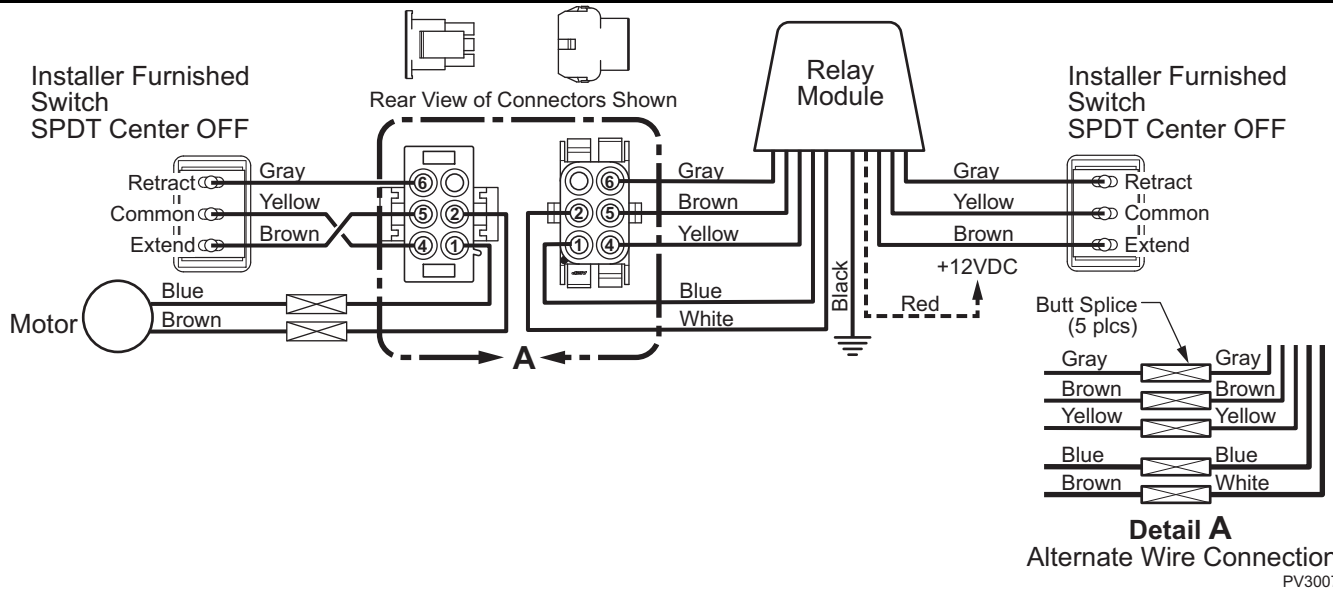

6. Restore vehicle power and test the switch operation. Note which direction extends the awning and which direction retracts the awning.
7. Orient the switch so that pushing the switch up corresponds with retracting the awning, pushing the switch down corresponds with extending the awning. Install the switch into the mounting surface.
NOTE: If the switch cannot be reoriented, reverse the top and bottom leads to the switch to reverse awning direction.
8. On the relay module, remove the paper cover on the adhesive foam and press the module onto a flat surface.

SETTING THE MOTOR LIMITS

The motor limit switches are preset at the factory for best operation of the awning. The "OUT" limit switch is used to stop the motor when the awning is fully extended. The "IN" limit switch is used to stop the motor when the awning is fully retracted.

For motor replacement and/or if limit adjustments are necessary, refer to the "Marquee Service Manual" available on-line @ www.carefreeofcolorado.com

OPTIONAL FACTORY INSTALLED LED (OEM)

1. Follow the standard mounting instructions for the awning (these are found in the awning installation instructions).
2. The twisted wire cable for the LED lighting is routed along the top of one arm and into the vehicle with the motor cable wire. Seal the hole and wires with a quality silicone sealant.

NOTE: There is approximately 13 feet of wire from the wall entry point. Controls should be located within this distance.

CAUTIONS:

- ⚠ The wire should be secured to the wall of the vehicle where it is exposed on the outside of the vehicle. Use a quality silicone sealant/adhesive.
- ⚠ Do not route the wire over sharp edges or heat sources that can cut or fray the wires or wire insulation.
- ⚠ Damage that is a result of improper routing may void warranty.

Switch Installation

NOTE: Installers may choose to furnish the control switch. The installation requires that the power line (+12VDC) be attached to a dedicated 2A circuit breaker or a 2A in-line fuse must be installed between the switch and power source. For easy access, locate the fuse close to the switch.

1. Determine the location of the switch.
2. At the switch location, cut a 1 1/8" x 1 1/2" hole.
3. Wire the switch as shown below. Wire terminals at the switch are .187, 18-24 awg female disconnects.

NOTE: Allow adequate slack in the 12VDC power line so that the in-line fuse (installed in step 4) can be accessed from behind the switch.

4. Install the in-line fuse:
 - 4.1. Near the switch, cut the red 12VDC power line to the switch. Do not strip the insulation.
 - 4.2. Insert a wire end into one of the wire channels until it butts up against the stop.
 - 4.3. Fold that half of the connector body over until the element contacts the wire. Use pliers to crimp the connector closed.
 - 4.4. Repeat for the second wire end.
 - 4.5. Slide the fuse into the fuse port. Ensure that it is firmly seated.

5. Press the in-line fuse, wires and switch into the mounting hole. Secure the switch using two (2) #6 x 1/2" screws.

6. Snap the switch bezel over the switch frame.

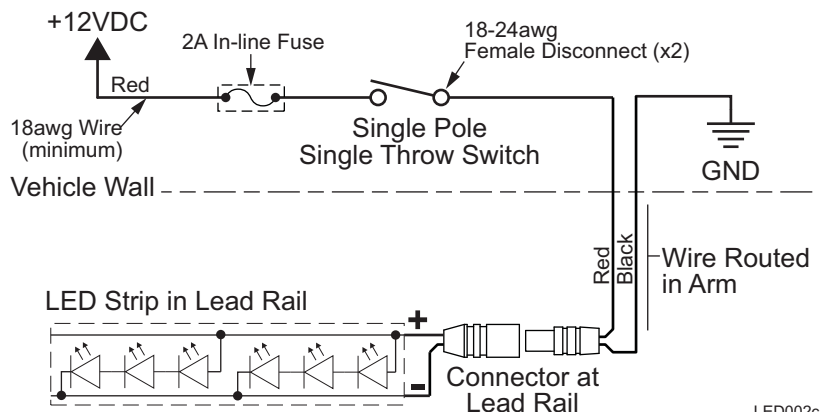
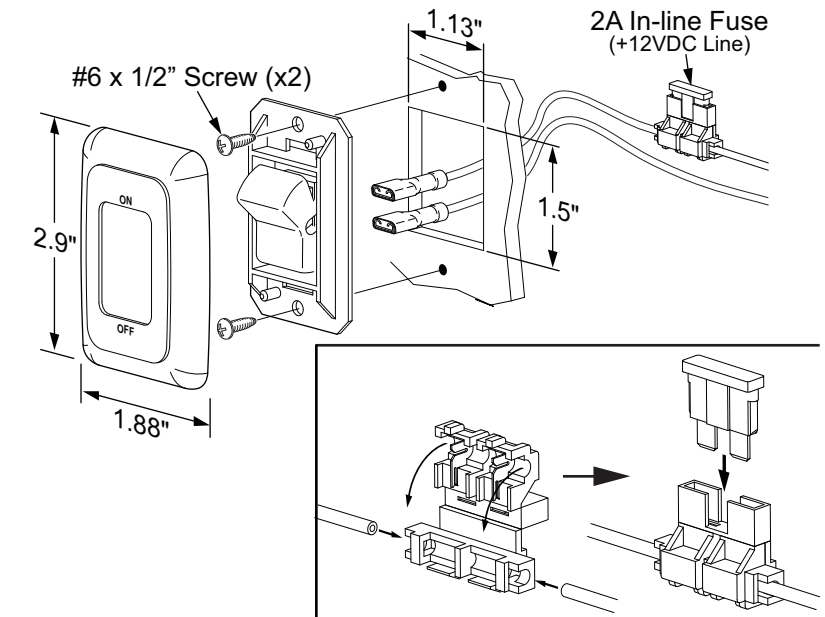

LED002c