



Service Manual APEX

RV

With Direct Response Electronics



Single Awning

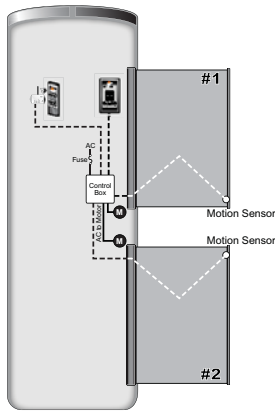

Dual Awnings

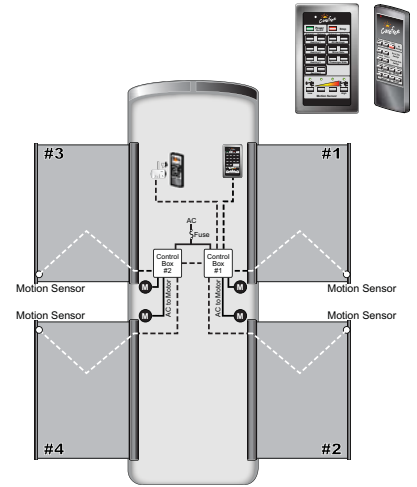

4 - Awnings

RTA105b

For LED parts and service, refer to 070013-301 "LED Service Manual for Box Awnings" available on-line at www.carefreeofcolorado.com

TABLE OF CONTENTS

Product Overview	1
Apex Patio Awning Specifications.....	1
Standard System Adjustments	2
Setting the Motor Limits.....	2
OUT Limit Switch	2
IN Limit Switch	3
Adjusting the Pitch.....	3
Programming the Remote Receiver	4
Operational Notes:.....	4
Key FOB Batteries	5
Manual Override	5
Standard Maintenance.....	6
Fabric Care	6
Mildew	6
Pooling	6
Arm Care.....	6
Motor Maintenance	6
Canopy Replacement	7
Motor Replacement	8
Modifying the Top Cover.....	10
Spring Arm Replacement	11
Replacing the Arm	11
Replacing the Lead Rail Connector:	12
Replacing the Case Arm Support.....	12
Removing the Awning	13
Diagnostics/Troubleshooting	14
Common Operation Items	14
Diagnostic Tests – Direct Response for Single Awning.....	15
Testing the System – Single Awnings	15
Diagnostic Tests – Direct Response for Multiple Awnings	18
Testing the System – Multiple Awnings	18
Electrical	22
Wiring Diagram – Single Awning	23
Wiring Diagram – 2-Awnings	24
Wiring Diagram – 4 Awnings	26
Connection Flex w/ "110VDR" Control Boxes	28
Optional Manual Bypass Switch	28
Sensor Replacement for Direct Response	29
Installing the Vertical Mount Bracket.....	29
Installing a New Sensor	30
Replacing the Touch-Pad with a Key Pad	31
Remove the Existing Control Pad	31
Installing the New Key Pad	31
Illustrated Parts Listings	32
Serial Number Location	32
Awning Components.....	32
Electronics Components.....	34
Component Identification.....	36
Control Panel and Remotes Identification.....	36
Control Box Enclosure Identification	37

PROPRIETARY STATEMENT

The Apex Awning is a product of Carefree of Colorado, located in Broomfield, Colorado, USA. The information contained in or disclosed in this document is considered proprietary to Carefree of Colorado. Every effort has been made to ensure that the information presented in the document is accurate and complete. However, Carefree of Colorado assumes no liability for errors or for any damages that result from the use of this document.

The information contained in this manual pertains to the current configuration of the models listed on the title page. Earlier model configurations may differ from the information given. Carefree of Colorado reserves the right to cancel, change, alter or add any parts and assemblies, described in this manual, without prior notice.

Carefree of Colorado agrees to allow the reproduction of this document for use with Carefree of Colorado products only. Any other reproduction or translation of this document in whole or part is strictly prohibited without prior written approval from Carefree of Colorado.

SAFETY INFORMATION



This is the safety alert symbol. It is used to alert individuals to potential personal injury hazards. Obey all safety messages that follow this symbol to avoid possible personal injury or death.



Indicates a hazardous situation, which if not avoided, could result in death or serious bodily injury.

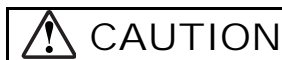

Indicates a hazardous situation, which if not avoided, may result in minor or moderate bodily injury.



Indicates a situation that may result in equipment-related damage.

General Safety:



WARNING Shock Hazard. Always disconnect battery or power source before working on or around the electrical system.



WARNING Always wear appropriate safety equipment (i.e. goggles).



CAUTION Always use appropriate lifting devices and/or helpers when lifting or holding heavy objects.



When using fasteners, do not over tighten. Soft materials such as fiberglass and aluminum can be "stripped out" and lose the ability to grip and hold.

CALIFORNIA PROPOSITION 65

WARNING This product contains chemicals known to the state of California to cause cancer or birth defects or other reproductive harm. California's Proposition 65 requires this warning to be given to customers in the state of California.

Reference Publications located at www.carefreeofcolorado.com:

- 052522-002: Apex Installation Manual
- 052522-201 Apex Owner's Manual, Single Awning, Switch Button Controls
- 052522-220 Apex Owner's Manual, Multiple Awning, Full Time Direct Response
- 052522-230 Apex Owner's Manual, Multiple Awning, Key Pad Controls
- 052522-301 Apex Service Manual

Electric components in this product have been tested by the following agencies:



Motor: UL Recognized (USA)
CSA Approved (Canada)



Controls: UL Listed (USA & Canada)

PRODUCT OVERVIEW

The Apex Patio Awning offers the coach owner an awning system that provides as much or as little shade as required. The canopies are housed in an aluminum case that easily blends in with the coach roof. The awning extends to a maximum of 10 feet from the side wall. The canopy is made from Acrylic fabric.

Each unit is equipped with lateral support arms that are the strongest available on the market. No vertical arms interfere with coach sidewalls or equipment that may be mounted on the roof. These arms can also be adjusted to vary the canopy pitch up to 3 feet (it is strongly recommended that service and adjustments be performed by trained technicians).

The unique and innovative 110V electronic control system provides Carefree's *Direct Response* system with interior touch pad controls for standard extend/retract functions. At the master control panel the auto-retract system can be engaged to automatically retract the awnings in windy conditions with sensitivity, set by the user, to respond to a variety of wind speed conditions. An RF remote is furnished with the *Direct Response* system.

Apex Patio Awning Specifications

The following information is for reference only. Specific information is detailed in the installation instructions.

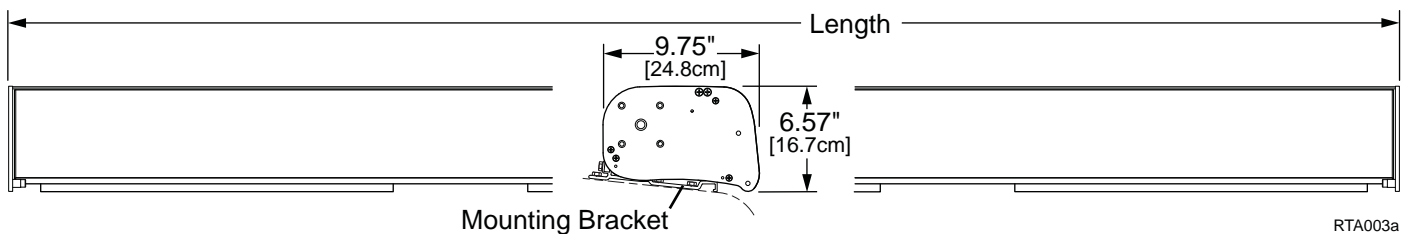

LENGTH	12' [3.7m] – 21' [6.4m] (in 1 foot [.305m] increments)		
EXTENSION:	10' [3m]	DROP:	12" [30.5cm] @ Minimum Pitch; 36" [91.4cm] @ Maximum Pitch
<i>Values are approximate, actual dimensions may vary with specific installations.</i>			
MOTOR:	Tubular	Available in LH or RH configurations	
	Power:	120V, 60Hz, 2.5A	Torque: 60nm Speed: 14 RPM
CONTROLS:	Direct Response with a single master control and single remote for all awnings.		
COLOR:	Hardware:	Black	
	Fabric:	Woven Acrylic (refer to sales literature for colors)	

APPROXIMATE WEIGHT (LBS.)					
Awning Length (ft.)	Weight	Awning Length (ft.)	Weight	Awning Length (ft.)	Weight
12	155	16	192	20	227
13	162	17	198	21	234
14	169	18	205		
15	185	19	216		

- Notes:
1. The Apex awning measurement is end of case to end of case.
 2. The awning uses 4 mounting brackets that are 7" wide and 24" long.

Optional factory installed 12V LED lighting (mounted in the lead rail) is available for the Apex awning. LED lighting requires a separate 12V control switch.

There are two configurations of the Apex based on the canopy construction as shown.

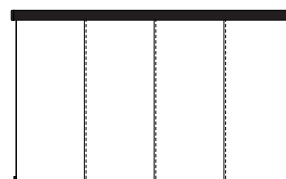

VS Configuration
Canopy construction with vertical seams

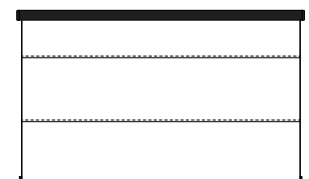

HS Configuration
Canopy construction with horizontal seams

Mirage056

STANDARD SYSTEM ADJUSTMENTS

SETTING THE MOTOR LIMITS

The "OUT" limit switch stops the motor when the awning is fully extended. The "IN" limit switch is used to stop the motor when the awning is fully retracted. The "IN" limit is NOT USED with the *Direct Response* system.

The limit switches are located inside the case, near the end plate.

To access the switches:

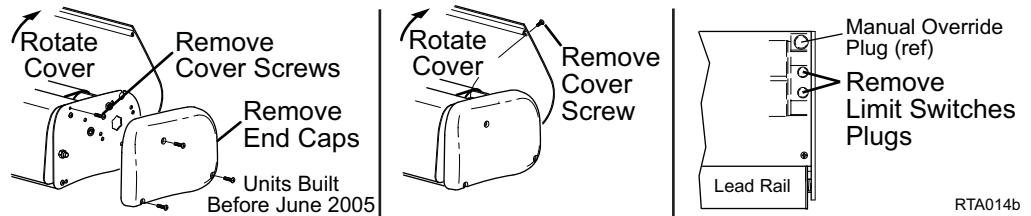

RTA014b

Configuration 1 (Discontinued)

NOTE: There are three (3) motor limit switch configurations. Visually inspect the limit switches to determine which configuration is installed in the awning. Use the illustrations to determine the correct turning direction for adjustments.

LH Motor **RH Motor**

Configuration 2 (Inactive)

The limit switches are located inside the case, near the end plate. To access the switches, remove the rubber plugs on top of the case next to the end plate.

Configuration 3 (Current)

Configuration 1 (Discontinued)

Configuration 2 (Inactive)

Configuration 3 (Current)

Paramount014

OUT Limit Switch

1. Extend the awning out completely.
2. Confirm that the arms are fully extended. The motor should stop and the fabric should be tight. If the motor continues to run, the fabric will sag; or, if the motor quits before the arms are fully extended, it will be necessary to adjust the "OUT" limit switch.

NOTE: It is best to make the adjustments in increments of a single turn. 3 full turns of the screw equals approximately 2" of fabric extension.
3. If the fabric sags:
 - 3.1. Retract the awning until the fabric is tight then retract an addition 10"-12".
 - 3.2. Using a 4mm Allen wrench turn the "OUT" limit switch to reduce the time the motor runs.
 - 3.3. Extend to confirm that the adjustment is correct.
 - 3.4. Repeat the procedure until the awning extends correctly.
4. If the arms do not extend completely:
 - 4.1. Retract the awning approximately 10"-12".
 - 4.2. Using a 4mm Allen wrench turn the "OUT" limit switch to increase the time the motor runs.
 - 4.3. Extend to confirm that the adjustment is correct.
 - 4.4. Repeat the procedure until the awning extends correctly.

IN Limit Switch

NOTE: The "IN" limit switch is not adjusted with the Direct Response system. The system electronics monitors the motor and shuts the motor off when the awning is fully retracted.

If the IN limit switch is accidentally adjusted, the motor may shut off before the awning is fully closed. If this occurs, turn the "IN" adjustment screw to INCREASE the motor run time. It is not necessary that the screw matches the closed position.

NOTE: It is normal for the lead rail to slightly relax after the awning closes completely.

ADJUSTING THE PITCH

The awning is factory set with minimum pitch. The amount of adjustment for increasing pitch may be limited by the mounting height above a door opening. The diagram chart below provides the minimum distance required above an opening with a swing-out door or window when the awning is set at MINIMUM and MAXIMUM pitch:

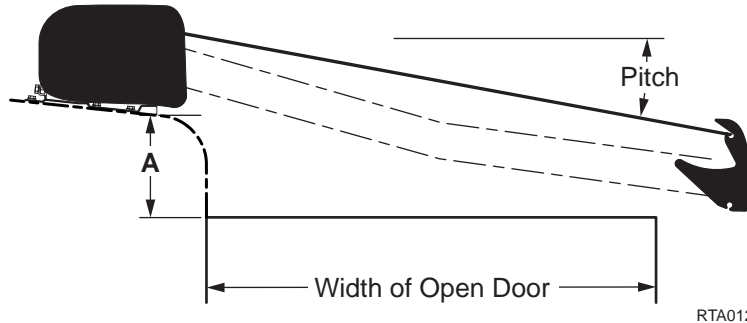

Door Width	0"	12"	18"	24"	30"	36"
A @ MINIMUM PITCH	1"	1.25"	1.5"	1.75"	2"	2.5"
A @ MAXIMUM PITCH	1"	3.5"	5.25"	7"	8.75"	10.5"

NOTE: Minimum Height (A) is measured from the door opening to the bottom of the mounting plate. The value given is a minimum requirement.

NOTICE During installation or when the pitch of the awning is adjusted, it is important that the lead rail is parallel to the awning housing.

1. Extend the awning fully.
2. (refer to Detail A) On one end, loosen the 6mm hex drive screw located on the spring arm knuckle.
3. SLIGHTLY loosen the 3/4" hex head (screw) on the side of the knuckle.
4. Turn the 3/4" adjustment nut located on the bottom of the knuckle. CLOCKWISE raises the pitch, COUNTERCLOCKWISE lowers the pitch.
5. Repeat steps 2 through 4 for the other end. Note the caution information above.
6. When the pitch adjustments are completed, tighten the set screw (6mm allens head) and the 3/4" hex head (screw) on the side of the knuckle.

NOTE: When raising the pitch, it is helpful to have a second person lift up on the lead rail.

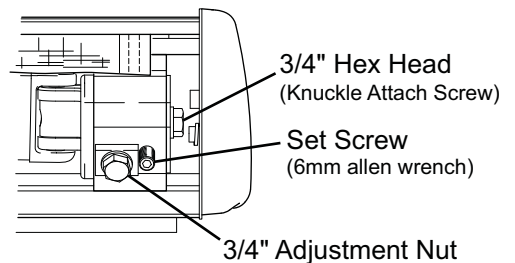

DETAIL A

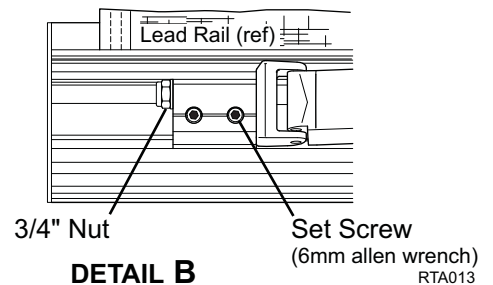

DETAIL B

When the pitch is adjusted, it is necessary to adjust the angle of the lead rail for the awning to close correctly. (Refer to Detail B).

7. SLIGHTLY loosen the 3/4" nut on the side of each arm knuckle on the lead rail.
8. Turn the INSIDE set screws (6mm allens wrench) of each knuckle to increase or decrease the angle of the lead rail. The bottom of the lead rail should be parallel with the ground.
9. When the lead rail adjustments are completed, tighten the 3/4" nut on the side of the knuckles.

PROGRAMMING THE REMOTE RECEIVER

Early transmitters & receivers operate on a frequency of 418MHz. Models for 2007 & on operate on 433MHz. The transmitter and receiver frequencies must match. Frequency identification is described under the operational notes below.

1. Power to the control box must be on.
2. Press and release the "Press to Learn Transmitter" button on the bottom of the receiver box. The receiver is in program mode when the red light comes on.
3. For Gray Button Key FOBS & Multiple Awning Remotes: Press and release ANY button on the remote. It is recommended to use the STOP button. The red light will go out after the receiver learns the remote signal.

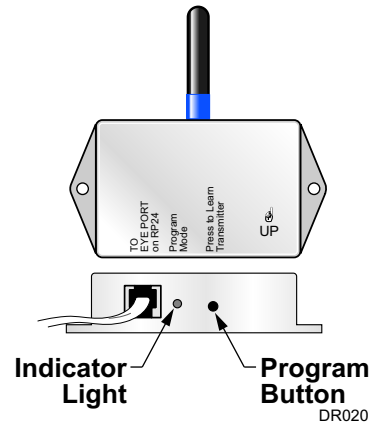

NOTICE When the receiver learns the transmitter signal the system will perform the operation of the button pressed. Example: Pressing an "Extend" button during the learning phase will cause the awning to extend when the receiver learns the signal. Use caution to avoid unexpected movement by the awning.

4. For Key FOBS w/ Antenna: Press and release the STOP button on the remote. The red light will go out after the receiver learns the remote signal.

NOTE: Pressing the stop button will cause the blue up arrow button to default as the open (extend) function. If a function button is pressed to train the receiver, it will be programmed as the open (extend) button. Example: Pressing the bottom button will program the bottom button for extend and the top button as retract.

5. Repeat for each additional remote.

Operational Notes:

- a. Transmitter and receiver must match in frequency (418 MHz or 433 MHz).

Key FOBS:

- The gray button Key FOBS are marked with a label for 418MHz or 433MHz.
- Key FOBS w/ antenna are 433MHz.
- Multiple awning remotes WITHOUT a "Stop All" button are 418 MHz.
- Multiple awning remotes WITH a "Stop All" button are 433 MHz

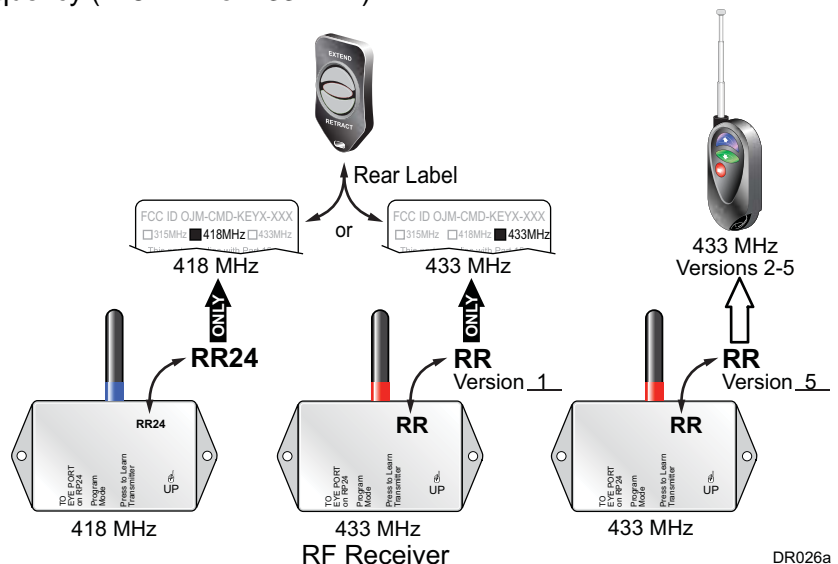

Receivers:

- 418 MHz receivers are marked "RR24".
 - 433 MHz receivers marked "RR" Version-1 can only be used with the 433 MHz gray button Key FOB.
 - 433 MHz receivers marked "RR" Version-2 can be used with either of the 433 MHz Key FOBs.
 - If replacing the remote receiver, version 5 is compatible with 433MHz key fobs versions 2 thru 5. If the key fob is an older version, it will be necessary to replace the key FOB.
- b. The receiver exits the program mode after ten seconds.
 - c. If the light does not come on above, the memory is full and must be cleared.
 - d. If the light does not go out above, the receiver already knows the transmitter's signal or the battery in the remote needs to be replaced.
 - e. To clear the memory: PRESS AND HOLD the transmitter learn button. While holding the button, the indicator light should be OFF for the full 5 seconds then come on.
 - f. The system may be programmed for up to 5 remotes. Additional remotes may be ordered separately.

Key FOB Batteries

The Gray Button Key FOB remote uses a flat 3V Lithium Battery (p/n CR2032) that should provide a long period of service. To access: carefully pry off the back of the case. Lift the circuit board out then slide the old battery out of the battery holder and slide a new battery in. The + should face away from the circuit board.

The Key FOB remote w/ antenna uses a battery (Radio Shack p/n 23-279 or equivalent) that should provide a long period of service. To access: Remove the small screw from the back of the case and carefully snap off the back. Lift the old battery out and insert the new battery.

Multiple awning remotes use two standard AAA Batteries that should provide a long period of service. To access: open the access cover on the back of the case.

Batteries are available through local battery outlets.

Battery life is dependent on frequency of use, environmental conditions and condition of remote.

MANUAL OVERRIDE

If 110V power is not available to the coach, the Apex awning can still be safely retracted using the manual override. The bypass is located inside the case, near the end cap.

The limit switches are located inside the case, near the end plate.

To access the switches:

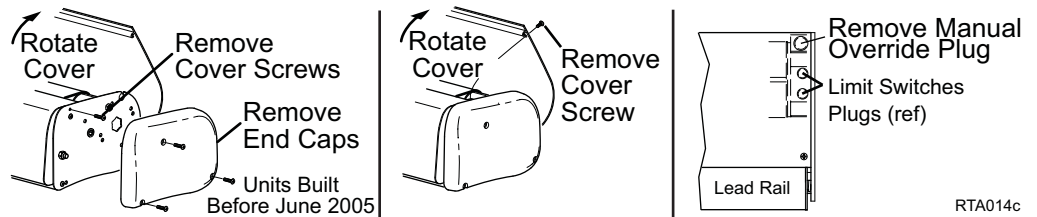

RTA014c

1. Chuck the 7mm hex key into a 3/8" battery powered drill.
2. Insert the hex key into the manual override on the awning.
3. Operate the drill in the direction shown in the diagram to close the awning. Reverse the drill to open the awning.
4. Reinsert the rubber plug or reattach the top cover.

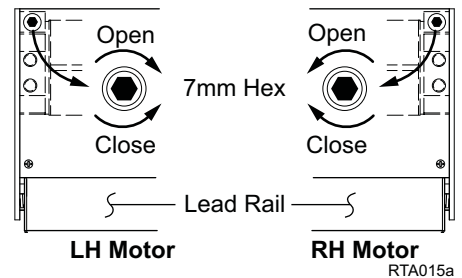

STANDARD MAINTENANCE

Maintaining the Carefree APEX Awning is easy. Just follow these basic steps:

- Always operate the awning according to the instructions.
- Periodically check that the fasteners are tight. Tighten if necessary.
- Keep the awning fabric and arms clean.

Fabric Care

NOTICE Do not use oil based cleaners or any caustic, granulated, or abrasive type cleaners on your Carefree product.

1. One of the best ways to keep the fabric looking good and to delay the need for deep or vigorous cleanings is to hose fabrics off on a monthly basis with clear water. This practice will help prevent dirt from becoming deeply imbedded in the fabric. In most environments, a thorough cleaning will be needed every two to three years.
2. When it's time for a thorough cleaning, the fabric can be cleaned while still on an awning frame.
 - For Vinyl Fabric – Use a soft brush and warm water with soap.
 - For Acrylic Fabric – Use a stiff brush and warm water with soap.
3. When cleaning the fabric, it is important to observe the following:
 - Always use a natural soap, never detergent.
 - Water should be cold to lukewarm, never more than 100°F.
 - Air-dry only. Never apply heat to the fabric.
 - Always allow the fabric to dry thoroughly before rolling up the awning.

Mildew

Mildew is a fungus growth that looks like dirt. Vinyl coated polyester fabrics are mildew resistant because of a chemical biocide in the vinyl coating. Under ordinary conditions, mildew will not appear. However, in areas where high temperature and humidity are common, mildew can be a problem and required the material to be washed more frequently. Thoroughly rinse the fabric with clean water and allow to air dry completely before rolling up the awning.

Pooling

When water collects on the top of the fabric, this is known as "pooling". This can occur during inclement weather or if a running air conditioner discharges over the awning. The water is dumped when the awning is retracted. It is recommended that if water accumulates on the top; retract the awning in steps (8"-12") to dump the water. This will help prevent the fabric from stretching or distorting.

The effects of wind and rain on an awning are unpredictable. Severe damage to the awning and the vehicle may result. IF WIND OR EXTENDED PERIODS OF RAIN ARE EXPECTED, ROLL UP THE AWNING AND SECURE FOR TRAVEL.

Arm Care

The best method of keeping the arms and braces operating smoothly is to clean them. Dirt and debris can cause the channels not to slide easily.

NOTE: Avoid introducing water into the motorized housings.

Periodically wash out the channels with running water (i.e. a hose) to keep them clean. If the channels still do not slide easily, lightly spray the joints with a dry silicone lubricant after the arms have been cleaned and dried thoroughly.

Motor Maintenance

- Check all wiring and connections for wear. Repair when needed.

CANOPY REPLACEMENT

1. Disconnect power to the awning.
2. Using the manual override (page 5), open the awning 18"-24".
3. Push the lead rail toward the case so that the arms collapse and the fabric is slack. Firmly tie the elbows of the spring arms together. Use a minimum 1/2" rope - do not use bungee cords. When tying the rope, use a non-slip knot such as a square knot or equivalent.

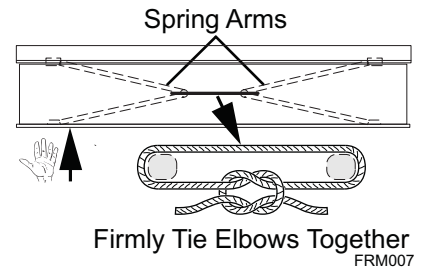

CAUTION Failure to secure the lead rail as described will allow the spring arms to extend out possibly causing personal injury and damage to the awning.

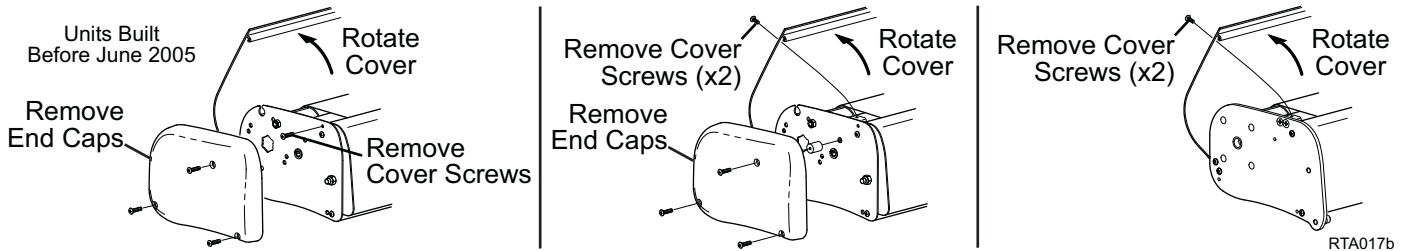

1. If installed, remove the end cap from the idler side.

NOTE: On early units, the attach screws for the cover went through the end plates, under the end caps. If this is an older unit, it will be necessary to remove both end caps to access the cover screws.

2. Remove the cover screws holding the top cover. Rotate the top cover back and out of the way. If rotated back without obstructions, the top cover will disengage from the pivot rail and can be set aside.
3. Remove the two fabric retainer screws on both sides of the lead rail and set aside.
4. Using the manual override, completely unroll the canopy to expose the fabric slot of the roller tube.
5. Remove the retainer screw from the idler end of the roller tube. There is no screw on the motor side.
6. Remove the idler end plate and set aside.
7. From the idler side, slide the old canopy out of the roller tube and lead rail.

NOTE: It will be necessary to support the roller tube do not allow the roller tube to pull off the motor.

8. Slide the new canopy into the lead rail and roller together. The large polycord goes into the lead rail, the smaller polycord goes into the roller tube. The hem should be on the down side.

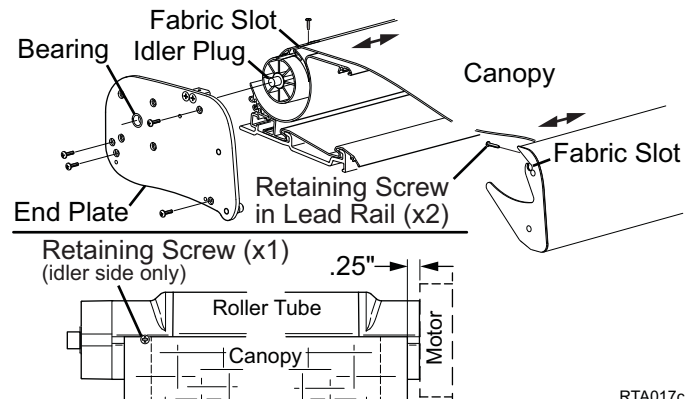

9. The the canopy should be approximately .25" from the end of the motor crown.
10. Attach the end plate to the case with the roller tube idler plug seated into the glide bearing.
11. In the fabric slot on the idler side, stake the canopy to the roller tube using one (1) #8 x 1" flat head screw through the fabric, polyrod and roller tube.
12. Use the manual override to roll the canopy onto the roller tube, the material must roll over the top of the roller tube. Ensure the fabric rolls evenly onto the roller tube.
13. Once the fabric is taut, remove the rope used to secure the arms previously.
14. Restore power to the awning.
15. Extend and retract the awning to confirm the canopy is centered and rolls up correctly. Adjust as required.
16. Install the fabric retainer screws in the lead rail.
17. It may be necessary to adjust the motor limits. Refer to page 3.
18. Install the top cover.

MOTOR REPLACEMENT



WARNING Shock Hazard. Always disconnect battery or power source before working on or around the electrical system.

Important Note: The current replacement motor for the VS configuration awnings has a slightly different configuration for the limit switch locations. The new motor is orange and has different graphics around the limit switches (see page 23 for comparison). If replacing an original configuration motor, it will be necessary to modify the top cover limit switch access holes. This modification should be done prior to removing and replacing the motor to avoid damaging the new motor. See "Modifying the Top Cover" on page 10.

This procedure requires a minimum of two people.

For multiple awning installations where the awnings are mounted end to end it will be necessary to move the unaffected awning if the motors are next to each other.

1. Disconnect power to the awning(s).
2. To move an adjacent unaffected awning:
 - 2.1. Close the awning if open.
 - 2.2. Loosen the retaining bolts in the back of the mounting plates.
 - 2.3. Slide the awning away from the other awning; allow a minimum of 6" to 8" between awnings.
 - 2.4. Temporarily tighten at least one of the retaining screws.

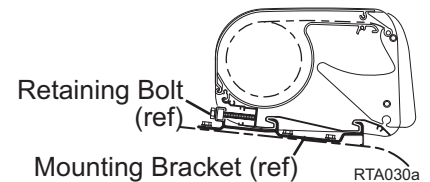

Replacing the motor:

1. Disconnect power to the awning.
2. Disconnect the motor wires at the junction box or control box and pull the cable out.
3. Use the manual override (refer to page 5) to over extend the awning. The arms should be extended completely, the canopy should be relaxed and the fabric slot of the roller tube should point up.

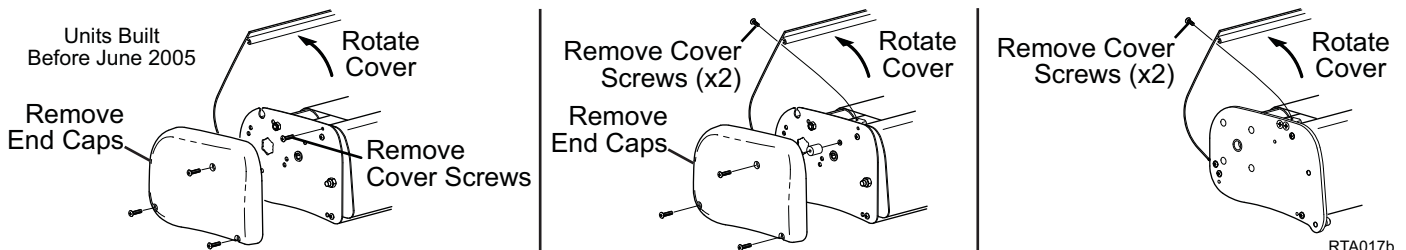

4. If installed, remove the end cap from the motor side.

NOTE: On early units, the attach screws for the cover went through the end plates, under the end caps. If this is an older unit, it will be necessary to remove both end caps to access the cover screws.

5. Remove the cover screws holding the top cover. Rotate the top cover back and out of the way. If rotated back without obstructions, the top cover will disengage from the pivot rail and can be set aside.

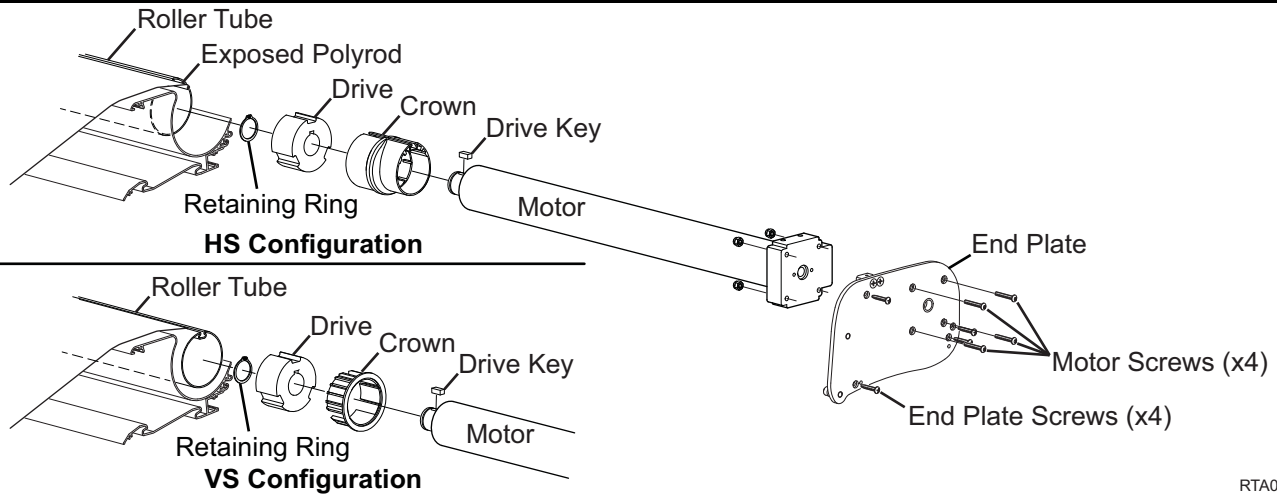

RTA030b

6. Remove the attaching screws for the end plate then carefully pull the end plate and motor partially out from the awning case.
7. Remove the screws and nuts holding the motor to the end plate. Set the end plate aside. Note the orientation of the motor then pull the motor, crown and drive out of the roller tube.

NOTE: For the HS configuration: When the crown is removed the canopy edge with the polyrod will be exposed and extend past the roller tube.

8. For HS configuration: Remove the crown from the old motor. This will be used with the new motor. The crowns are configuration specific.
9. Assemble the new motor:

NOTE: The new and old motor components are not interchangeable.

- 9.1. Slide the crown onto the motor.

NOTE: For VS configurations, use the new crown that is included with the motor. For HS configurations, discard the included crown and use the existing crown that was removed previously.

- 9.2. Place the drive key into the slot of the motor shaft and slide the new drive onto the motor shaft and over the drive key.
- 9.3. Secure the drive using the supplied retaining ring.

10. Attach the new motor assembly to the end plate using the new screws and nuts provided.
11. Slide the new motor assembly into the roller tube. Ensure that the motor drive gear and crown are properly seated inside the roller tube.

NOTICE For the HS configuration: When the crown is seated in the roller tube, the canopy edge with the polyrod must be in the fabric groove of the crown.

12. Route the motor cable through the access hole in the back of the case.
13. Ensure the roller tube idler plug is seated in the glide bearing.
14. Position motor end plate on the case and attach using the screws removed previously.
15. Route the new motor wire into the vehicle and attach at the junction box or control box (refer to wiring diagrams on page 22 for the appropriate control system). **All wiring must conform to NEC (National Electrical Code) and local codes.**
16. Use the manual override to begin rolling the canopy onto the roller tube, the material must roll over the top of the roller tube. Ensure the fabric rolls evenly onto the roller tube.
17. Restore power to the awning.
18. Extend and retract the awning.
19. It will be necessary to adjust the motor limits. Refer to page 2.
20. Install the top cover and end caps if installed previously.
21. Reposition the adjacent awning if it has been moved. Ensure that all the retaining bolts are properly tightened.

MODIFYING THE TOP COVER

When replacing an older configuration motor with the current motor, it is necessary to modify the top cover access holes for the limit switches.

1. Remove and save the two (3) small plugs from the top of the cover.
2. Measure and mark the new hole locations.
3. Drill two (2) $\frac{3}{8}$ " holes through the cover in the locations marked.
4. Clean and deburr the holes.
5. Insert the two plugs removed previously into the original holes.
6. Insert the new plugs into the new holes. The plugs will overlap.
7. Open the top cover and continue with the motor replacement. Clean any shavings that may have fallen into the case.

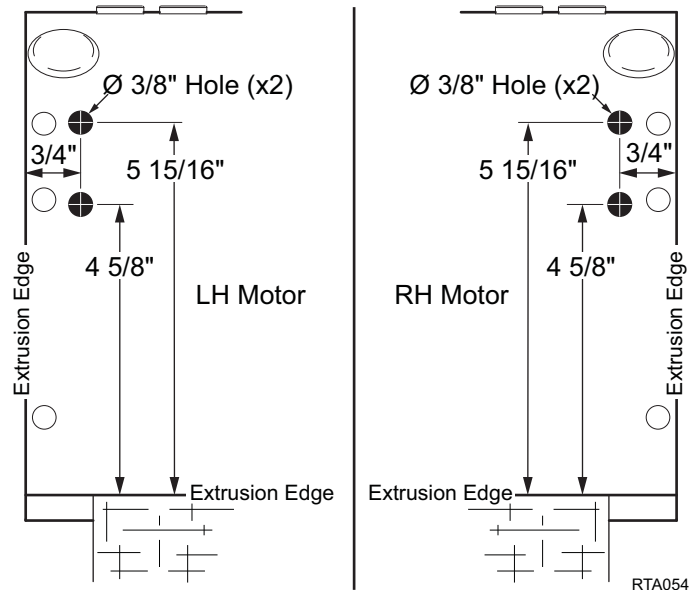

SPRING ARM REPLACEMENT

CAUTION The spring arm is under tension to open. Use extreme care to firmly hold the spring arms during assembly and disassembly to avoid any sudden or unexpected movement by the arm. Serious personal injury and/or property damage could occur.

NOTE: If replacing an original series arm, it will be necessary to also replace the lead rail connector (page 12)

REPLACING THE ARM

The following procedure requires two people.

1. Open the awning to the maximum extension or as wide as possible. This is to minimize the spring tension in the arms during this procedure.
2. Disconnect power to the awning.
3. Use a scaffold, ladder or other means to firmly support the lead rail.
4. For arms with the sensor cable mounted, carefully remove the sensor cable from the wire channel on top of the arm. Use care to not bend, break or compromise the cable.
5. (refer to Detail A) At the lead rail, remove the M12-1.25 lock washer and nut from the arm and lead rail connector.
6. Slightly loosen the 6mm adjustment screw. DO NOT loosen the outer set screw.
7. Firmly grasp the spring arm and slide the lead rail arm knuckle out of the lead rail connector. Allow the arm to extend to its maximum length outside the lead rail. Have a second person hold or otherwise support the unattached end.
8. (refer to Detail B) Inside the case, remove the M12-1.25 x 25 bolt and washer from the side of the arm support. Remove the M12-1.25 x 40 bolt, washer and saddle from the front of the support.
9. Slightly loosen the 6mm locking screw.
10. Firmly grasp the spring arm and slide the case arm knuckle out of the arm support. Set the old arm aside.
11. If the arm has wire channel mounted for the sensor cable, carefully remove the channel from the arm to reuse on the new arm.
12. On the replacement arm assembly, remove the lead rail connector and arm support bracket from the arm knuckles.

NOTE: The lead rail connector and arm support bracket are included in case there is damage to the existing brackets. If there is no damage, it is not necessary to replace them with the arm.

13. If replacing the lead rail connector or case arm support, go to page 12 then return to step 14.

14. Using two people firmly hold the new arm assembly and remove the shipping ties. Allow the arm to slowly open to its maximum extension.

Tip: Use a floor or ground cover and place one knuckle and arm half on the ground. Have one person firmly hold the arm half on the ground while the second person carefully opens the other arm half.

15. Lift the arm assembly into position.

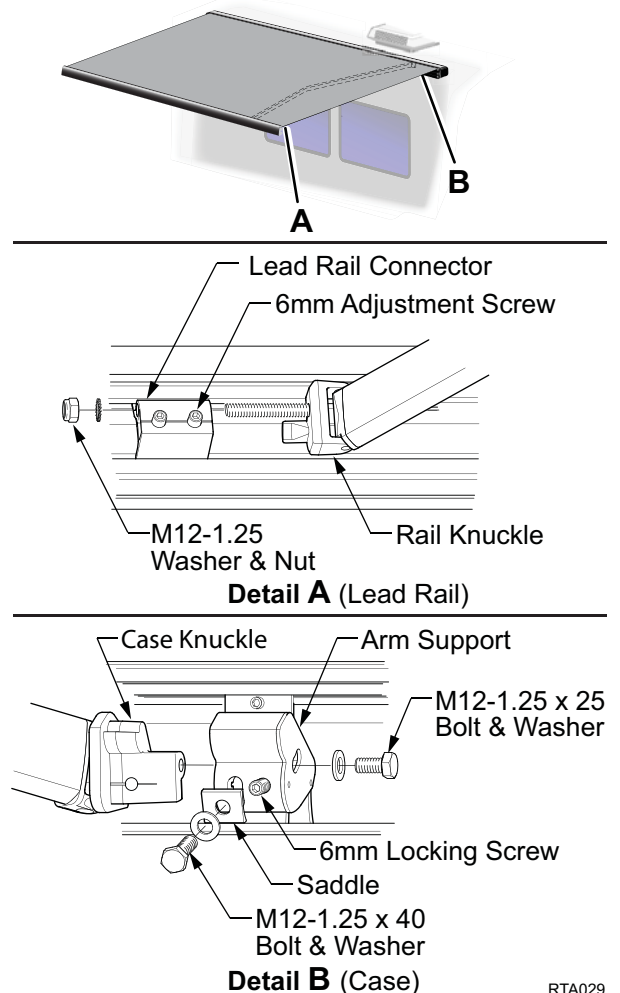

RTA029

16. (refer to Detail B) Slide the case arm knuckle into the support inside the case and secure with 1 each M12-1.25 x 25 bolt and washer and 1 each M12-1.25 x 40 bolt, washer and saddle. Do not tighten at this time.
17. (refer to Detail A) Insert the lead rail arm knuckle into the lead rail connector and secure with 1 each M12-1.25 bolt, washer and nut. Do not tighten at this time.
18. If the sensor cable is routed on the replacement arm:
 - Attach a piece of wire channel to the top of each section of the arm. If using new channel, cut each piece slightly shorter than the arm extrusion. Attach the channel using double sided tape.
 - Route the cable through the wire channel. At the arm joints, arch the cable slightly to avoid binding. Do not twist the cable.

Tip: Use a small tool, such as a flat bladed screwdriver to gently spread open the channel then insert the cable. Do this for the entire length of the channel until the cable is fully inserted.
19. Adjust the arm pitch as required. Follow the procedure for pitch adjustment on page 3.
20. Extend and retract the awning several times. This will allow the canopy to self-center.
21. It may be necessary to adjust the motor limits. Refer to page 2.

Replacing the Lead Rail Connector:

1. Remove the lead rail end plate.
2. Carefully mark the location of the existing connector.
3. Loosen the 6mm securing screw and slide the existing connector from the lead rail.
4. Insert the new connector assembly into the lead rail and position at the marks made previously.
5. Tighten the outer 6mm securing screw.
6. Attach the lead rail end plate.

Replacing the Case Arm Support

1. Carefully mark the location of the existing support.
2. Open the upper cover of the case.
3. Remove the end cap if installed.
4. Remove the end plate.
 - 4.1. *For the idler side*, remove the end plate screws then slide the end plate off of the roller tube idler and set aside.
 - 4.2. *For the motor side*, remove the end plate screws and slide the end plate and motor out 4"-6".
5. Loosen the clamping screws on the support and slide the old support out of the case.
6. Insert the new support assembly into the case and position at the marks made previously.
7. Tighten the clamping screws.
8. Reinstall the end plate.
 - 8.1. On the idler side ensure that the idler pin of the roller tube is properly seated.
 - 8.2. On the motor side ensure the drive and crown are properly seated in the roller tube.
9. Close and secure the top cover if open
10. Reinstall the end caps if previously installed.
11. Return to step 14 on the previous page.

REMOVING THE AWNING



CAUTION

The Apex awning is extremely heavy. Moving and/or lifting the awning requires a minimum of 3 people. The use of a lifting device is strongly recommended.

1. Retract the awning completely.
2. Disconnect power to the awning.
3. Locate the junction box where the motor wires are routed. Disconnect the motor wires and remove from the junction box. Make note of the wire colors. Bundle the wire to the awning.

NOTE: Some installations use a waterproof junction box located on the top of the coach, others may have the junction box located inside the coach at or near the cable entry point.
4. Disconnect the sensor cable.
 - For installations with a junction box: Some installs may route the cable into a junction box with a cable coupler. Disconnect the cable from the awning and remove from the junction box. Bundle the cable to the awning.
 - For installations hardwired to the control box (option 1). Trace the cable to the control box. Disconnect the cable from the control box and remove from the coach. Bundle the cable to the awning.
 - For installations hardwired to the control box (option 2). If it is not possible to disconnect the cable from the control box and remove from the coach, locate the cable inside the coach and at a convenient point, cut the cable. Pull the cable out and bundle to the awning. If using this method, it will be necessary to order a cable coupler and two phone cable connectors when reinstalling the awning.
5. The awning is mounted using 4 mounting brackets attached to the roof of the coach. Each mounting bracket has a retaining bolt in the back side to hold the awning into the bracket. Loosen all 4 of the retaining bolts. It is not necessary to remove the bolts from the brackets.
6. Slide the awning back and up to remove the awning from the brackets.
7. To reinstall the awning, reverse the procedure above.

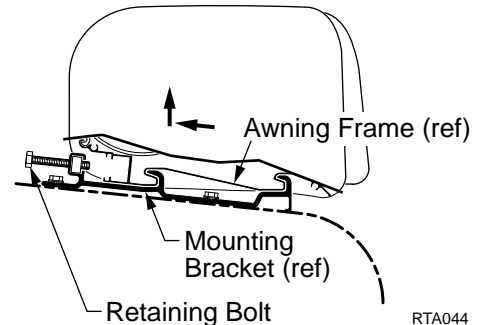

RTA044

Special Notes:

- a) When attaching the motor wires ensure that the wire colors match the previous configuration. All wiring must conform to NEC (National Electrical Code) and local codes.
 - b) If the sensor cable was cut to remove the awning, it is necessary to install a connector on each cut end of the cable. The connector must be attached as shown in the wiring diagrams on page 22. A coupler is then used to attach the two connectors.
8. After installing the awning, test the operation (refer to page 15 – Single Awning or page 18 – Multiple Awnings).

DIAGNOSTICS/TROUBLESHOOTING

The following procedures are intended to aid the service technician to logically resolve operational issues with the *Direct Response* installation.

Refer to the appropriate wiring diagram:

- Wiring Diagram – Single Awning page 23
- Wiring Diagram – Dual Awnings page 24
- Wiring Diagram – 4 Awnings page 26

<i>Procedures in this section:</i>	<i>Page</i>
<u>COMMON OPERATION ITEMS</u>	14
<u>DIAGNOSTIC TESTS – DIRECT RESPONSE FOR SINGLE AWNING</u>	15
<u>TESTING THE SYSTEM – SINGLE AWNINGS</u>	15
<u>D01 THE AWNING DOES NOT OPERATE</u>	16
<u>D02 THE AWNING OPERATES DIFFERENTLY THAN THE SWITCH MARKINGS</u>	17
<u>D03 AWNING DOES NOT AUTO-RETRACT IN WIND</u>	17
<u>DIAGNOSTIC TESTS – DIRECT RESPONSE FOR MULTIPLE AWNINGS</u>	18
<u>TESTING THE SYSTEM – MULTIPLE AWNINGS</u>	18
<u>D04 THE AWNING(S) OPERATE DIFFERENT THAN THE SWITCH MARKINGS</u>	19
<u>D05 THE AWNINGS DO NOT OPERATE (ALL)</u>	19
<u>D06 ONE AWNING DOES NOT OPERATE</u>	20
<u>D07 AWNING(S) DO NOT RETRACT DURING WINDY CONDITIONS</u>	20
<u>D08 AWNING DOES NOT MOVE WHEN REMOTE CONTROL BUTTONS ARE PUSHED</u>	21

Common Operation Items

The following items are operational items that may come up as questions during normal operation. These are also given in the operator's manual.

1. Each awning has an independent motion sensor. During windy conditions, the awnings may not retract concurrently.
2. If the optional Carefree EL ignition lockout is installed the system will disable the extend function while the vehicle ignition key is in the ON position.

Special order RTL ignition lockouts will fully retract the awning(s) and disable the extend function.

Functions will return to normal operation when the ignition key is turned OFF.

Coach manufacturers may install their own lockout design. Refer to the coach literature for AC power for accessories.

3. Pressing multiple buttons at the same time may cause the awnings to appear to move erratically. If this occurs, press the stop button. Use the individual controls to set the awning(s) to the desired position.
- 4.

DIAGNOSTIC TESTS – DIRECT RESPONSE FOR SINGLE AWNING



WARNING Shock Hazard. Always disconnect battery or power source before working on or around the electrical system.

Refer to the Wiring Diagrams in the next section for wire and cable connections.

TESTING THE SYSTEM – SINGLE AWNINGS

When 110VAC power is removed from the system, the controller DOES NOT retain previous positioning information. When power is restored, positioning information is updated when the first function is initiated.

The function LEDs (extend, retract and stop) perform a dual function. When the button is pressed, the LED illuminates. The LED stays illuminated during the selected operation and after the awning has fully extended or retracted. This provides an indicator of the awning position. When the stop button is pressed, the LED will illuminate and stay on until a function is pressed. If on, it indicates that the awning is partially extended/retracted.

All function buttons are press ON/press OFF. The auto-functions will continue until the awning is fully extended/retracted or when the stop button is pressed.

1. While observing the control panel, have a second person initiate 110VAC power to the coach and awning system. The following should occur:
 - 1.1 The Auto-Retract and Wind Speed LEDs should illuminate briefly then extinguish.
 - 1.2 The Power ON/OFF and function/position LEDs will briefly illuminate.
 - 1.3 The system then goes to the default settings: The POWER “ON”, AUTO-RETRACT “ON” and MEDIUM Wind Speed LED will be on.

NOTE: The function/position LEDs (extend, stop and retract) will not be illuminated. During power up the controller does not retain position information. The controller is updated with the first function used.

2. Press the POWER “OFF”. ALL LEDs should extinguish. The POWER ON/OFF button disables all functions including Auto-Retract and the optional RF remote if installed. It does not disconnect the 110VAC power.
3. Press the POWER “ON”. Press the EXTEND button, the LED should illuminate while the awning extends and stay on after the awning auto-stops. Observe the awning, it should fully extend. The system performs an auto-tension action when the awning is fully extended. The awning rolls in reverse to tension the fabric. The auto-tension feature works only with the extend function when the awning is fully extended or the stop button is pushed while extending.
4. After the awning is fully extended, press the RETRACT button, the EXTEND LED should extinguish and the Retract LED should illuminate while the awning is retracting. Press the STOP button.
5. When the STOP button is pressed, the awning will stop, the RETRACT LED should extinguish and the STOP LED should illuminate.
6. Press the RETRACT button, allow the awning to retract fully, the Retract LED will illuminate and stay lit.
7. Press the AUTO-RETRACT OFF. The AUTO-RETRACT and WIND SPEED LEDs should go out.
8. Press the AUTO-RETRACT ON. Press each Wind Speed button and confirm that the LEDs illuminate.
9. Test the Auto-Retract function:
 - 9.1 Fully extend the awning.
 - 9.2 With the AUTO-RETRACT ON, set the WIND SPEED to the lowest setting.
 - 9.3 Create a firm but gentle rocking motion with the leading edge of the awning. The awning should retract after 2-3 seconds of the motion.
10. *If the optional Ignition Sensor is installed:*
 - 10.1 Partially retract the awning.
 - 10.2 Turn the ignition key ON.
 - 10.3 Press the EXTEND button. The LED should flash for 2 seconds then shut off and the previous function LED will come back on.

In the charts below, YES is a positive response to the test; NO is a negative response.

D01 THE AWNING DOES NOT OPERATE			
A	Confirm 110VAC power to control box.		
	1. Shut off power source. 2. Open control box. 3. On some early units a fuse is installed on the circuit board (if installed). Check that fuses on circuit boards are intact. 4. Check that 110VAC connections are correct and secure. Refer to correct system schematic.	YES	Power is present; go to test B
		NO	Check vehicle circuits and fuses. Repair as required and retest
B	Confirm awning motor is functioning		
1	1.1 With power off, disconnect motor wires and AC power in from switches (system #1) or control box. 1.2 Connect awning motor directly to 110VAC power source. Motor White to Neutral (White) of AC cord Motor Green to Ground (Green) of AC cord Motor Red & Black are Motor Direction Control – connect Red to AC Hot (Black). 1.3 While observing awning, briefly apply power. 1.4 Disconnect power and attach other motor direction control wire (Black) to AC Hot (Black). 1.5 While observing awning, briefly apply power. 1.6 Does awning move when power is applied? Note: If the awning runs but does not extend or retract completely, it may be necessary to adjust the motor limits (refer to page 2).	YES	Awning motor is good, control circuit is defective – test and repair Go to Step C
		NO	Go to step B-2
2	Test continuity and connections of motor wire between control box and junction box.	YES	Continuity is good, motor is defective – replace
		NO	Repair wire as required and retest

D01 Continued on next page

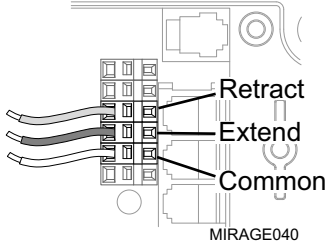
C	Test Touch Pad		
	1 Confirm 110VAC power to control box 1.1 Shut off power source. 1.2 Open control box. 1.3 On some early units a fuse is installed on the circuit board. Check that fuses on circuit boards are intact. 1.4 Check that 110VAC connections and splices to board is correct and secure. Refer to system schematic. 1.5 While observing the circuit boards, have power restored. The LEDs on the boards should blink red then green.	YES	Power is present; go to test B
		NO	Check vehicle circuits and fuses. Repair as required and retest
	2 Press the "Power On" button on the touch-pad. The "Power On" LED should illuminate.	YES	Power is on, go to step D-4
		NO	LED does not illuminate, go to step D-3
	3 Check the cable between the switch and control box. As a continuity check, Pin 1 of connector 1 goes to Pin 1 of connector 2; pin 2 goes to pin 2; pin 3 goes to pin 3 and pin 4 goes to pin 4.	YES	Continuity OK; go to step D-4
		NO	Replace cable and retest
	4 Check the function of the Touch pad 4.1 On the control board, locate the terminal strip next to the phone cord connectors. 4.2 Insert 3 wires into the terminals shown below 4.3 While observing the awning, short the wire ends between the Common and Extend terminals. Does the awning move? 4.4 Short the wire ends between the Common and Retract terminals. Does the awning move?	YES	Control Board is good, Touch pad is defective - replace
		NO	Control Board is defective – replace control box.
	 <p style="text-align: right;">MIRAGE040</p>		

D02 THE AWNING OPERATES DIFFERENTLY THAN THE SWITCH MARKINGS			
<i>This condition generally occurs during new installations or when major components have been replaced.</i>			
A	Does Awning operate in reverse of the switch plate labeling (i.e. extends when retract is pushed)?	YES	Motor wires from awning are reversed - locate motor wires in the control box, reverse the red and black wires.

D03 AWNING DOES NOT AUTO-RETRACT IN WIND			
A	Press the power on button then press the auto-retract button. Does the auto-retract LED flash?	YES	The flashing LED indicates that the sensor has been disengaged or otherwise disabled. Go to step C.
		NO	Function does not work with switch; go to procedure D01
B	Confirm that the retract function works using the push buttons.	YES	Function works using the switch; go to test C
		NO	Function does not work with switch; go to procedure D01
C	Test Motion Sensor		
	1 Confirm cable is plugged into connector on box marked "Shaker"	YES	Go to step 2
		NO	Correct as required and test.
	2 2.1 Unplug sensor from control box. 2.2 Connect a second sensor into control box. 2.3 Set the control switches for the auto retract function 2.4 Hold the second sensor horizontally and gently move up and down.	YES	Awning retracts; original sensor defective - replace
NO		Awning does not retract; control box defective - replace	

DIAGNOSTIC TESTS – DIRECT RESPONSE FOR MULTIPLE AWNINGS



! WARNING Shock Hazard. Always disconnect battery or power source before working on or around the electrical system.

Refer to the Wiring Diagrams in the next section for wire and cable connections.

TESTING THE SYSTEM – MULTIPLE AWNINGS

All function buttons are press ON. The auto-functions continue until the awning is fully extended or retracted. Pressing the button a second time will stop the function. It is not necessary to hold the button while the function is active.

1. While observing the control panel, have a second person initiate 110VAC power to the coach and awning system. The following should occur:
 - 1.1 The Power ON/OFF and Wind Speed LEDs will briefly illuminate.
 - 1.2 The system then goes to the default settings: The POWER “ON”, AUTO-RETRACT “ON” and MEDIUM Wind Speed LED will be on.

NOTE: If the awnings operate from the touch pad but no LEDs are illuminated, check that the jumper cable between the controllers is plugged into AUX (motor #1) and ACC (motor #2).

2. Press the POWER “OFF”. ALL LEDs should be extinguished. The POWER ON/OFF button disables all functions including Auto-Retract and the optional RF remote. It does not disconnect the 110VAC power.
3. Check the extend function.
 - 3.1 Press the POWER “ON”.
 - 3.2 Press the Awning #1 EXTEND button. The awning should extend.
 - 3.3 Press the extend button again. The awning should stop
 - 3.4 Press the extend button a third time. Observe the awning, it should fully extend. The system performs an auto-tension action when the awning is fully extended. The awning rolls in reverse to tension the fabric. The auto-tension feature works only with the extend function when the awning is fully extended.
4. Check the retract function.
 - 4.1 Press the Awning #1 RETRACT button. The awning should retract.
 - 4.2 Press the retract button again. The awning should stop
 - 4.3 Press the retract button a third time. Observe the awning; it should fully retract to the closed position.

NOTE: If the awning moves in the opposite direction than the label, the red and black MOTOR wires are reversed in the control box.

5. Repeat steps 3 and 4 for each of the Extend/Retract button combinations.

NOTE: The Extend All and Retract All buttons should extend/retract all awnings.

6. Test the Auto-Retract function:
 - 6.1 Fully extend awning #1.
 - 6.2 Set the WIND SPEED to the lowest setting.
 - 6.3 Create a firm but gentle vertical rocking motion with the leading edge of the awning. The awning should retract after 2-3 seconds of the motion.
7. Repeat step 6 for each of the awnings.
8. *If the optional Ignition Sensor is installed:*
 - 8.1 Partially retract the awning.
 - 8.2 Turn the vehicle ignition key ON.
 - 8.3 Press the EXTEND button. The awning(s) should not extend.

In the charts below, YES is a positive response to the test; NO is a negative response.

D04 THE AWNING(S) OPERATE DIFFERENT THAN THE SWITCH MARKINGS			
<i>The power switch at the touch pad must be on; the LED will be illuminated if power is present.</i>			
A	Does a different awning move when pressing the controls are pressed (i.e. Awning #2 moves when Awning #1 is pressed)? Board marked "Motor 1" corresponds with touch pad "Awning 1" etc.	YES	Awning #Y moves when Awning #X buttons are pressed. - Awning motor wires from Awning #X and Awning #Y are reversed. Remove motor wires from control boards, reattach motor #X wires to motor #X control board; motor #Y wires to motor #Y control board.
		NO	Go to test B
B	Does the awning operate in reverse of the switch plate labeling (i.e. extends when retract is pushed)	YES	Motor wires from affected awning are reversed in control box. - Open control box and locate motor wires from affected awning. Reverse the red and black wires. NOTE: <u>For LH motor configurations:</u> RED WIRE goes to terminal RED (1); BLACK WIRE goes to terminal BLACK (1). <u>For RH motor configurations:</u> BLACK WIRE goes to terminal RED (1); RED WIRE goes to terminal BLACK (1).
		NO	Reanalyze condition

D05 THE AWNINGS DO NOT OPERATE (ALL)			
<i>For one awning that does not operate, refer to D03</i>			
A	Confirm 110VAC power to control box 5. Shut off power source. 6. Open control box. 7. On some early units a fuse is installed on the circuit board. Check that fuses on circuit boards are intact. 8. Check that 110VAC connections and splices to both boards are correct and secure. Refer to system schematic. 9. While observing the circuit boards, have power restored. The LEDs on the boards should blink red then green.	YES	Power is present; go to test B
		NO	Check vehicle circuits and fuses. Repair as required and retest
B	Confirm that touch-pad operating.		
1	Press the "Power On" button on the touch-pad. The "Power On" LED should illuminate.	YES	Power is on, go to step B-4
		NO	LED does not illuminate, go to step B-2
2	At bridge, disconnect cable then observe LED while plugging cable into "BUS" of bridge. LED should flash red then green.	YES	Power is present, go to step B-4
		NO	Go to step B-3
3	Check the cable between the bridge and control box. As a continuity check, Pin 1 of connector 1 goes to Pin 1 of connector 2; pin 2 goes to pin 2; pin 3 goes to pin 3 and pin 4 goes to pin 4.	YES	Continuity OK; go to step B-4
		NO	Replace cable and retest
4	4.1 Disconnect jumper cable between controller boards. 4.2 Disconnect touch-pad from "ACC" of controller #1 and connect to "ACC" of controller #2. 4.3 Does Awning #2 operate when pressing a command button on the touch pad?	YES	Awning operates, Controller #1 is defective – Replace control box.
		NO	Awning does not respond, touch-pad/bridge is defective - replace

D06 ONE AWNING DOES NOT OPERATE

NOTE: The awnings are programmed sequentially (i.e. #1, #2, #3, #4). If power is missing from an awning, the subsequent awnings will not function (i.e. #1 and #2 works, #3 and #4 don't) and the touch-pad LEDs do not illuminate. Check the power to the first non functioning control board in sequence (i.e. #3) and correct as necessary before proceeding.

A	<ol style="list-style-type: none"> Shut off power source if not already done. Open control boxes and disconnect the non-working awning motor wires and a working awning's motor wires. Connect the non-operating awning to the functioning control board (i.e. awning #2 to control board #1). Restore power Test the operation of the awning using the controls for the functioning awning (in the example above #1 awning). 	YES	Awning functions, control board of non-working awning is defective – replace control box.
		NO	Return wires to original configuration. Go to step B
B	Confirm awning motor is functioning		
	<ol style="list-style-type: none"> <ol style="list-style-type: none"> With power off, connect awning motor directly to 110VAC power source. White = Hot Green = Ground Red & Black are Motor Direction Control – connect one Briefly apply power. Does awning move when power is applied? Test continuity and connections of motor wire between control box and awning motor. 	YES	Awning motor is good, control box is defective - replace
		NO	Go to step B-2
		YES	Continuity is good, motor is defective – replace
		NO	Repair as required and retest

D07 AWNING(S) DO NOT RETRACT DURING WINDY CONDITIONS

The Direct Response auto-retract system operates by gauging the motion of the awning's leading edge, not by the direct wind speed. Refer to the description in the operations section of the manual.

NOTE: The awnings have independent sensors and may not retract concurrently.

A	Press the power on button then press the auto-retract button. Do the auto-retract LED flash?	YES	The flashing LED indicate that the sensor(s) have been disengaged or other wise disabled. Go to step C
		NO	Go to test B
B	Confirm standard awning operation. From the touch-pad, operate the awnings.	YES	Operation is normal, Go to step C
		NO	Refer to the appropriate test D02 or D03
C	<ol style="list-style-type: none"> Check function of shaker sensor Open the affected awning (does not have to be open all the way). Open the second awning. Open control box and disconnect sensor from controller board of awning that does not auto-retract. If cable has been spliced between sensor and control box, check continuity of splice. Repair as required and retest before proceeding. Disconnect the sensor from the other controller and plug the cable into the "SHAKE" terminal of the affected awning controller. At touch-pad, turn power ON and auto-retract ON. Set auto-retract to the lowest setting. At the unaffected awning, create a firm but gentle rocking motion with the leading edge of the awning for about 3-4 seconds. 	YES	The affected awning retracts. Original sensor is defective replace. Return second shaker to the unaffected awning controller.
		NO	Awning does not retract, control box is defective – replace

NOTE: The touch pad LEDs will continue to flash after connecting good sensors. It is necessary to power off the system then turn it back on so that the touch-pad recognizes the sensors are connected

D08 AWNING DOES NOT MOVE WHEN REMOTE CONTROL BUTTONS ARE PUSHED			
	1. Confirm power is ON at the touch-pad	--	Correct as required
	2. Confirm batteries in remote are good. Pressing any button on the remote will illuminate the LED at the top of the remote.		Replace as needed
	3. Check the cable between the Receiver and control box. As a continuity check, Pin 1 of connector 1 goes to Pin 1 of connector 2; pin 2 goes to pin 2; pin 3 goes to pin 3 and pin 4 goes to pin 4. Cable must be plugged into the "BUS" port of controller #1.	YES	Cable is OK. Confirm that cable is securely plugged in; go to step 4
		NO	Repair or Replace cable as required.
	4. Confirm that the Receiver is programmed for the Remote	--	Refer to "Programming the Receiver" on page 4 and retest. If system does not work; go to step 5
	5. Program a second remote and test	YES	2 nd remote works. 1 st remote is defective.
		NO	2 nd remote does not work; go to step 6
	6. Replace the Receiver and test. (it will be necessary to program receiver for remote)	YES	System works OK. 1 st receiver is defective
		NO	System does not work. Reinstall 1 st receiver; go to step 7
	7. Replace control box	--	

ELECTRICAL

IMPORTANT NOTICES:

- Failure to follow the wiring instructions in this publication may void the motor warranty.
- All wiring must conform to NEC (National Electrical Code) and local codes.
- The SO cable from the 110VAC awning motor can only pass directly through a wall, it can not be laid up in the wall and must be connected to NM wire or individual wires in conduit no more than 6 inches past the point of entry.
- For 110VAC installations, enclosed junction boxes are required for all wire splices and direct connection switch installations. Boxes are required in conformance with prevailing construction codes. The servicing technician or installer is required to furnish the flush mounted, UL approved electrical duplex boxes where required.

The 110V electronic control system provides the user with simple pushbutton controls for the awnings installed. Four configurations are available:



WARNING Shock Hazard. Always disconnect battery or power source before working on or around the electrical system.

1) Direct Response for Single Awning Installations.

- System includes: Control box (single control board), Master control panel (w/ pushbutton awning control and windspeed sensitivity settings), motion sensor; and, an RF remote control.
- An optional ignition lockout is available.

2) Direct Response for Dual Awning Installations.

- System includes: Control box (2 control boards), Master control panel (w/ touchpad awning control and windspeed sensitivity settings), motion sensors; and, an RF remote control i.
- An optional ignition lockout is available.

3) Direct Response for Dual Awning Installations.

- System includes: 2-Control box (2 control boards each), Master control panel (w/ touchpad awning control and windspeed sensitivity settings), motion sensors; and, an RF remote control i.
- An optional ignition lockout is available.

The switches use a 5VDC signal to operate the control box; thus eliminating the need for a junction box for the control panel.

Components are connected using terminated cables. Terminated cable is 4-wire RJ11 terminated phone cord (straight, no twist). This does not include 110VAC power in or awning motor power.

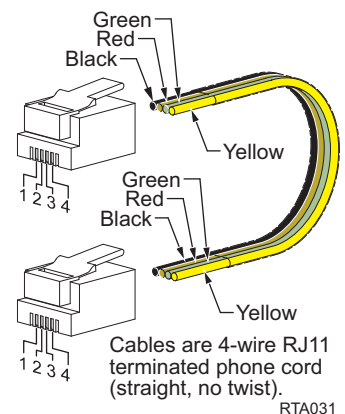

WIRING DIAGRAM – SINGLE AWNING

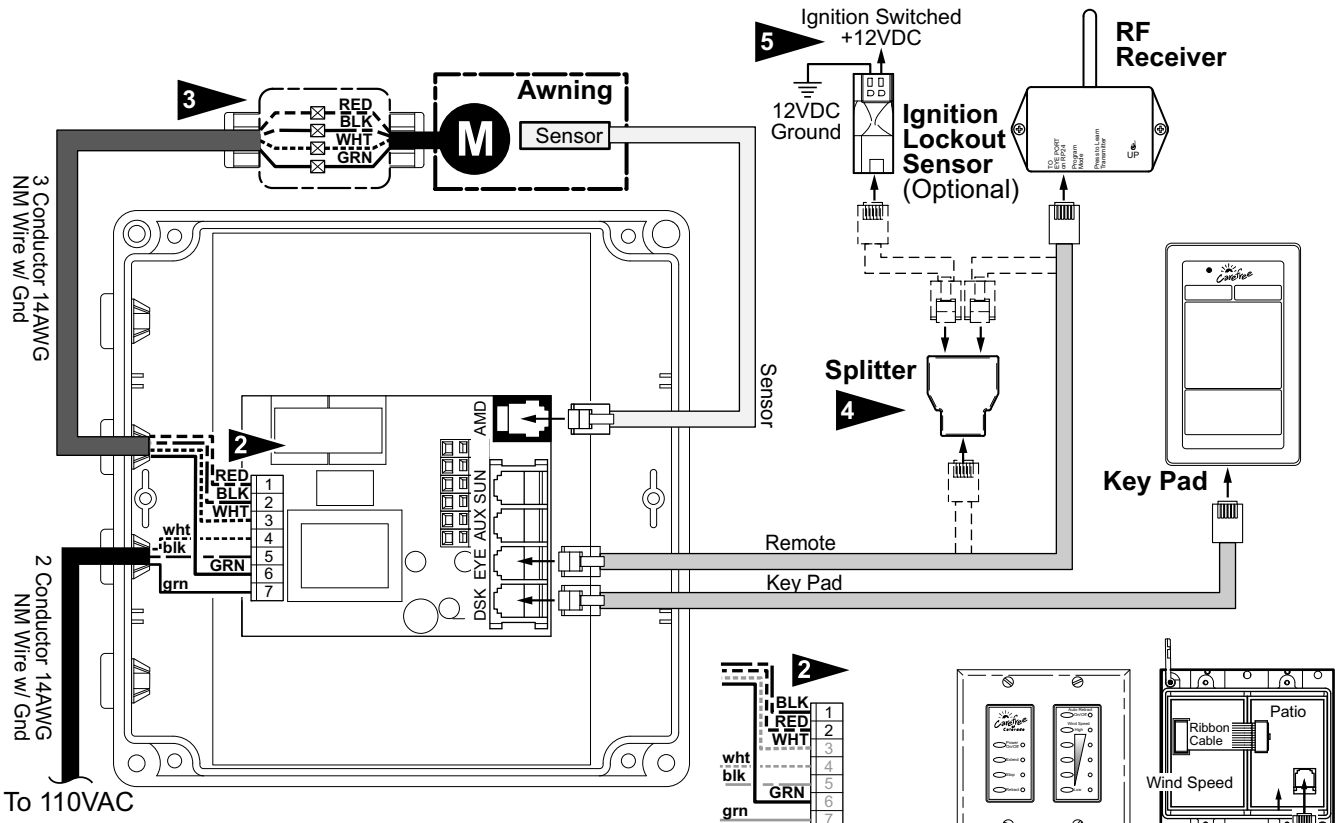

NOTES:

- 1** Wire Legend:
 - Red
 - Black
 - White
 - Green (Ground)
- 2** For LH Motor Configurations:
 Motor Red goes to Pin (1); Motor Black goes to Pin (2)
 For RH Motor Configurations:
 Motor Red goes to Pin (2) Black; Motor Black goes to pin (1)
- 3** The SO cable from the 110VAC awning motor can only pass through a wall, it cannot be laid up in the wall and must be connected to NM wire or individual wires in conduit no more than 6 inches past the point of entry.
- 4** Splitter is used only when Optional Lock-Out Sensor is installed. Connect RF Receiver directly to "EYE" if Lock-Out is not installed.
- 5** Wires for the Ignition Lock-Out Sensor are not pin specific.

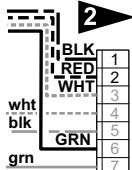

Detail A
For RH Configuration
Reverse Red & Black Wires

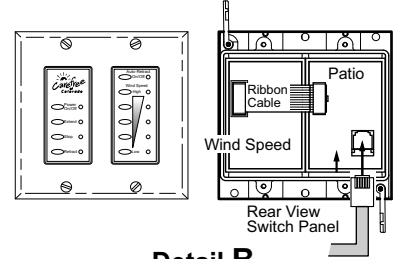

Detail B
Used thru 2006

DR012

FROM		TO (RH CONFIGURATION)		TO (LH CONFIGURATION)	
Motor	Black	Control Box	1	Control Box	2
	Red		2		1
	White		3		3
	Ground		6		6
AC Power Source	White	Control Box	4	Control Box	4
	Black		5		5
	Ground		7		7
Awning Sensor	10' Cable	Control Box	"AMD"	Control Box	"AMD"
Key Pad	60" Cable	Control Box	"DSK"	Control Box	"DSK"
Splitter	60" Cable	Control Box	"EYE"	Control Box	"EYE"
RF Receiver	60" Cable	Splitter		Splitter	
Ignition Lockout	60" Cable	Splitter		Splitter	

Notes: 1. Cable lengths are the lengths of the furnished cables. If a connection requires a length greater than the supplied cable, the installer must provide a terminated jumper cable from the box location to the cable end.

WIRING DIAGRAM - 2-AWNINGS

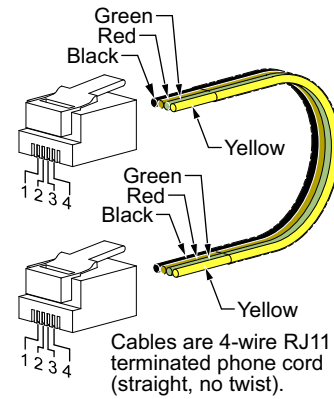
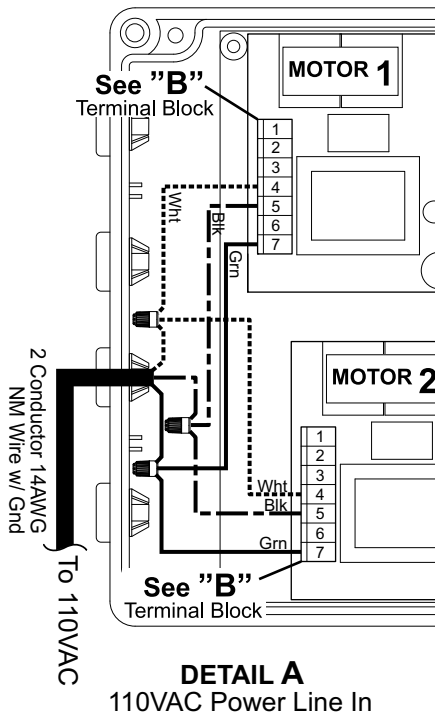
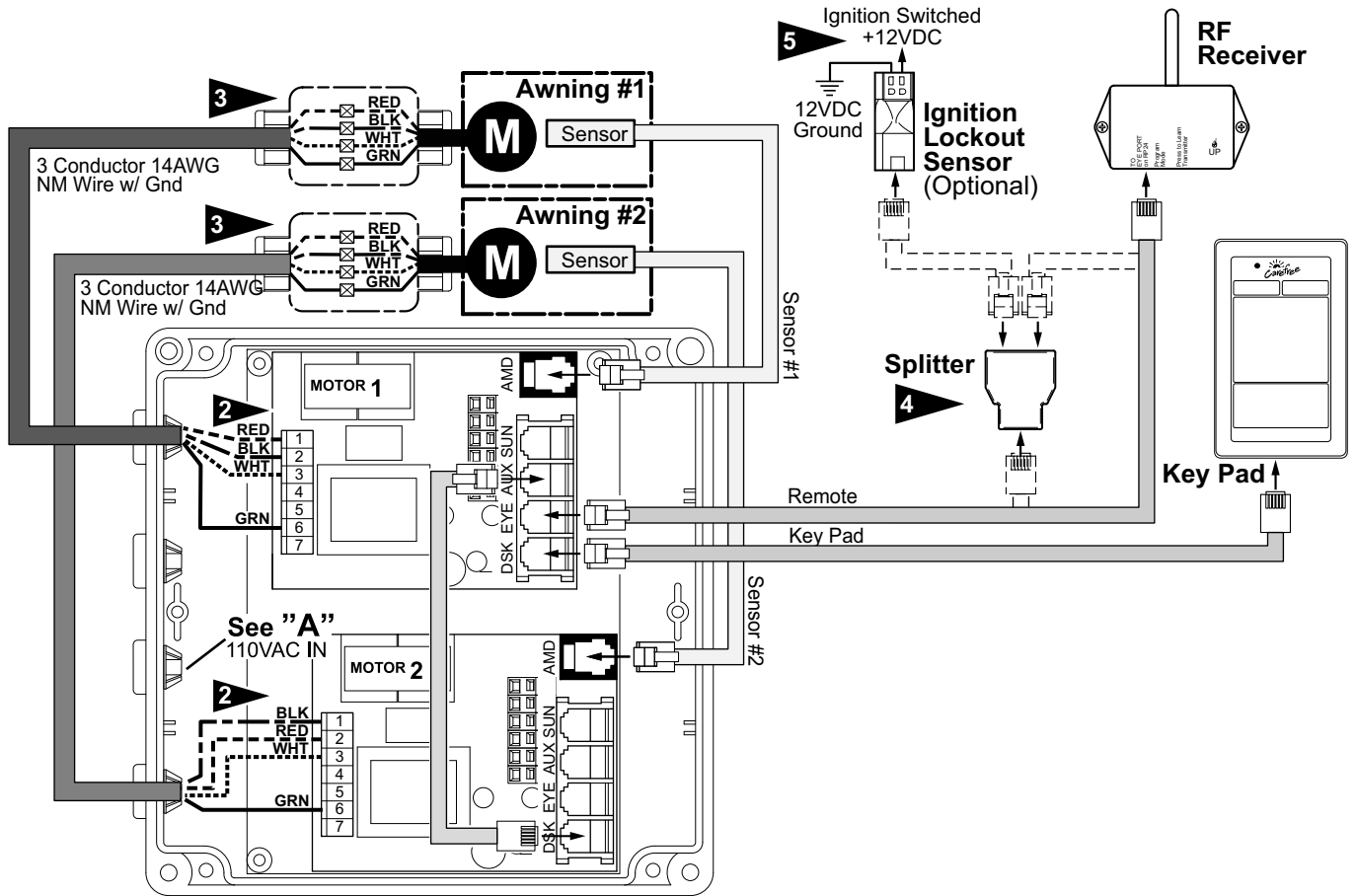

DR014

NOTES:

- 1 Wire Legend:
 ----- Red
 _____ Black
 White
 _____ Green (Ground)
- 2 Awnings #1 & #4 shown as LH Motor, Awnings #2 & #3 shown as RH Motor
For LH Motor Configurations:
 Motor Red goes to Pin (1); Motor Black goes to Pin (2)
For RH Motor Configurations:
 Motor Red goes to Pin (2); Motor Black goes to pin (1)
- 3 The SO cable from the 110VAC awning motor can only pass directly through a wall, it cannot be laid up in the wall and must be connected to NM wire or individual wires in conduit no more than 6 inches past the point of entry.
- 4 Splitter is used only when Optional Lock-Out Sensor is installed. Connect RF Receiver directly to "EYE" if Lock-Out is not installed.
- 5 Wires for the Ignition Lock-Out Sensor are not pin specific.
- 6 For screw type terminals: After testing connections, use Loctite 29005 or equivalent to secure screws in terminal block.
- 7 Cables are 4-wire RJ11 terminated phone cord (straight, no twist)
- 8 Terminal block designations are for reference only. Actual boards may not be marked.

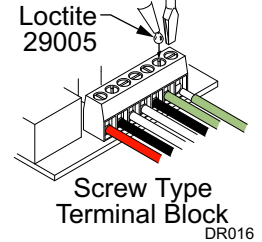

FROM		To (MOTOR #1)	To (MOTOR #2)	
AC Power Source	White	4	4	
	Black	5	5	
	Ground	7	7	
Awning #1 Motor	Black	Refer to Flag Note 2		
	Red			
	White			3
	Ground			6
Awning #2 Motor	Black		Refer to Flag Note 2	
	Red			
	White			3
	Ground			6
#1 Sensor	10' Cable	"AMD"		
#2 Sensor	10' Cable		"AMD"	
Key Pad	25' Cable	DSK		
Splitter	60" Cable	"EYE"		
RF Receiver	60" Cable	Splitter		
Ignition Lockout	60" Cable	Splitter		

Notes: 1. Cable lengths are the lengths of the furnished cables. If a connection requires a length greater than the supplied cable, the installer must provide a terminated jumper cable from the box location to the cable end.

WIRING DIAGRAM – 4 AWNINGS

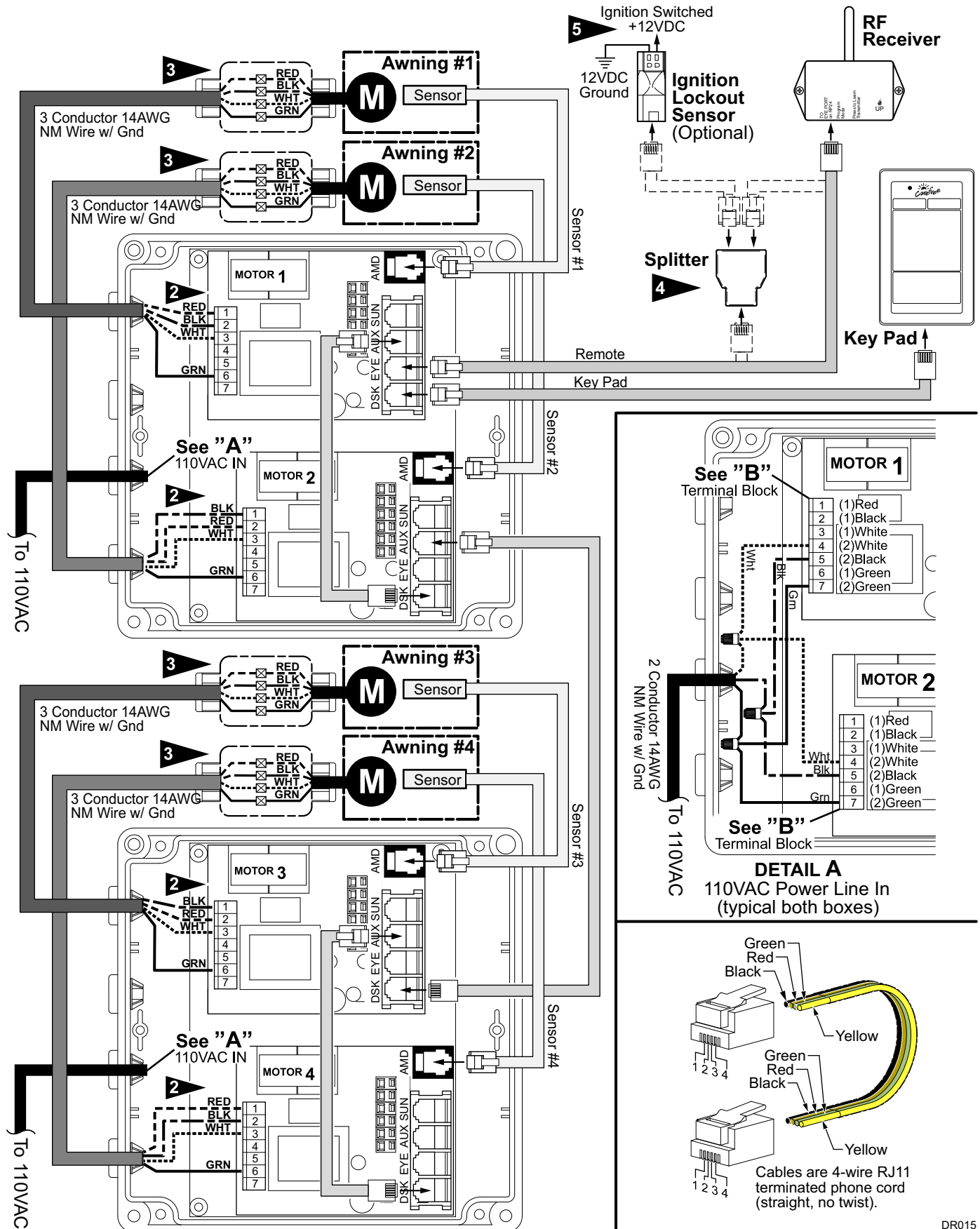

DR015

NOTES:

1 Wire Legend:
 ----- Red
 ----- Black
 ----- White
 ----- Green (Ground)

2 Awnings #1 & #4 shown as LH Motor, Awnings #2 & #3 shown as RH Motor

For LH Motor Configurations:

Motor Red goes to Pin (1); Motor Black goes to Pin (2)

For RH Motor Configurations:

Motor Red goes to Pin (2); Motor Black goes to pin (1)

3 The SO cable from the 110VAC awning motor can only pass directly through a wall, it cannot be laid up in the wall and must be connected to NM wire or individual wires in conduit no more than 6 inches past the point of entry.

4 Splitter is used only when Optional Lock-Out Sensor is installed. Connect RF Receiver directly to "EYE" if Lock-Out is not installed.

5 Wires for the Ignition Lock-Out Sensor are not pin specific.

6 For screw type terminals: After testing connections, use Loctite 29005 or equivalent to secure screws in terminal block.

7 Cables are 4-wire RJ11 terminated phone cord (straight, no twist)

8 Terminal block designations are for reference only. Actual boards may not be marked.

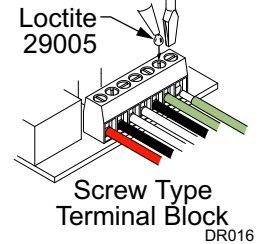

FROM		TO CONTROL BOARD				
		MOTOR #1	MOTOR #2	MOTOR #3	MOTOR #4	
AC Power Source	White	4	4	4	4	
	Black	5	5	5	5	
	Ground	7	7	7	7	
Awning #1 Motor	Black	Refer to Flag Note 2				
	Red					
	White					3
	Ground					6
Awning #2 Motor	Black		Refer to Flag Note 2			
	Red					
	White					3
	Ground					6
Awning #3 Motor	Black			Refer to Flag Note 2		
	Red					
	White					3
	Ground					6
Awning #4 Motor	Black				Refer to Flag Note 2	
	Red					
	White					3
	Ground					6
#1 Sensor	10' Cable	"AMD"				
#2 Sensor	10' Cable		"AMD"			
#3 Sensor	10' Cable			"AMD"		
#4 Sensor	10' Cable				"AMD"	
Key Pad	25' Cable	"DSK"				
Splitter	60" Cable	"EYE"				
RF Receiver	60" Cable	Splitter				
Ignition Lockout	60" Cable	Splitter				

Notes:
 2. Splitter is used w/ Ignition Lock-Out only. If Lock-Out is not installed, connect the receiver directly to "EYE".
 3. Cable lengths are the lengths of the furnished cables. If a connection requires a length greater than the supplied cable, the installer must provide a terminated jumper cable from the box location to the cable end.

CONNECTION FLEX W/ "110VDR" CONTROL BOXES

The wiring diagrams show the standard installation for multiple awning configurations. For control boxes marked w/ "110VDR", the installer may adjust the cable interconnections for greater flexibility during installation.

1. The key pad may be installed in the unused DSK port of any board with the jumper cables sequentially connected from the AUX port to the DSK port of the next board.

Example: Placing the keypad in the DSK of Board 3.

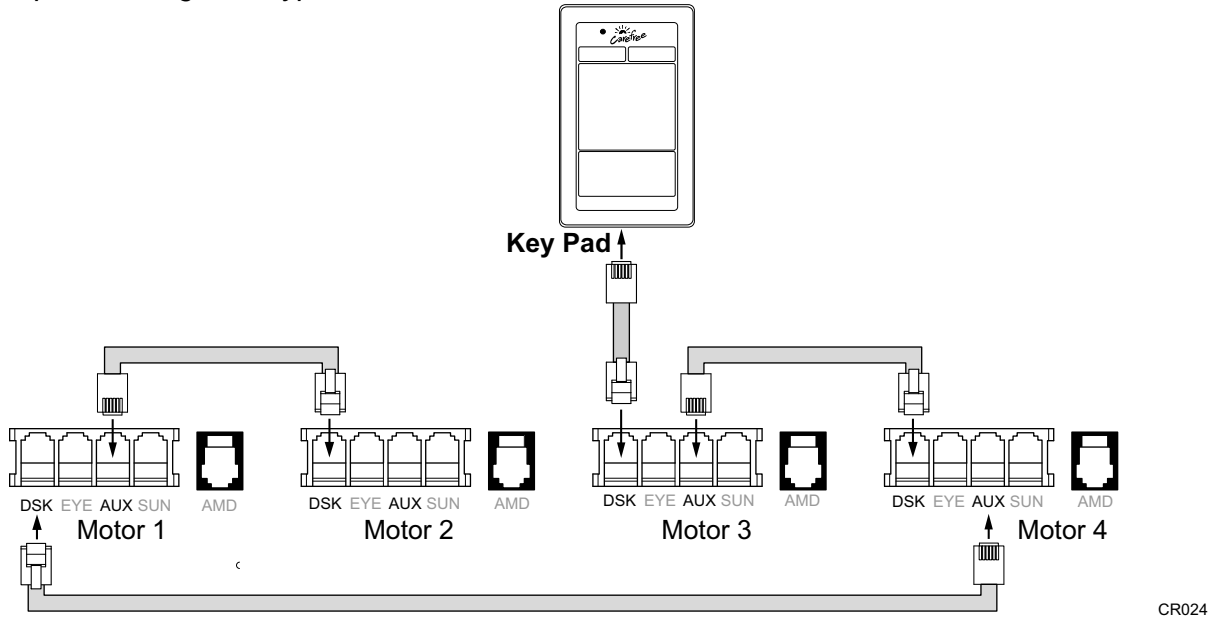

2. The RF Receiver and the optional ignition lock-out can be plugged into any unused "EYE" port. It is not necessary to use the splitter as shown in the diagrams.
3. The "110VDR" control boxes are compatible with integrator interfaces. Contact Carefree engineering for information and system requirements.

OPTIONAL MANUAL BYPASS SWITCH

Installers may elect to install a manual bypass switch for testing or emergency operation of the awning. The simple switch allows the operator to extend or retract the awning without using the keypad control panel. For multiple awning installations, a separate switch must be installed for each awning.

1. Open the control box and identify the terminal block next to the phone cord jacks.
2. Connect the switch to the terminal block as shown in the diagram.

The switch is a single pole, double throw, momentary ON, center OFF. Components are installer furnished.

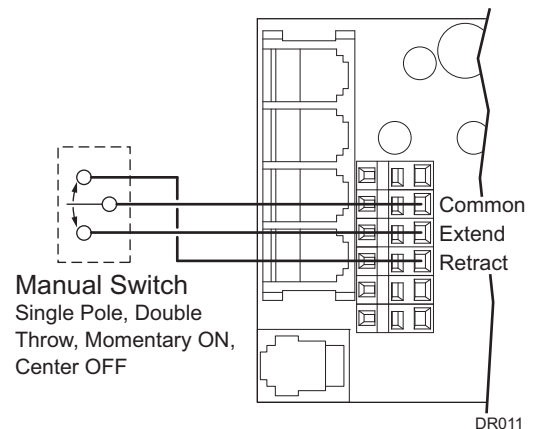

SENSOR REPLACEMENT FOR DIRECT RESPONSE

NOTICE The original Direct Response Shake Sensor was mounted horizontally on the inside of the lead rail. For product integrity, sensors are now mounted vertically. If replacing an original horizontally mounted sensor, it is necessary to install the vertical mounting bracket for the replacement sensor. Replacement sensors must be mounted vertically and will not work properly if mounted horizontally.

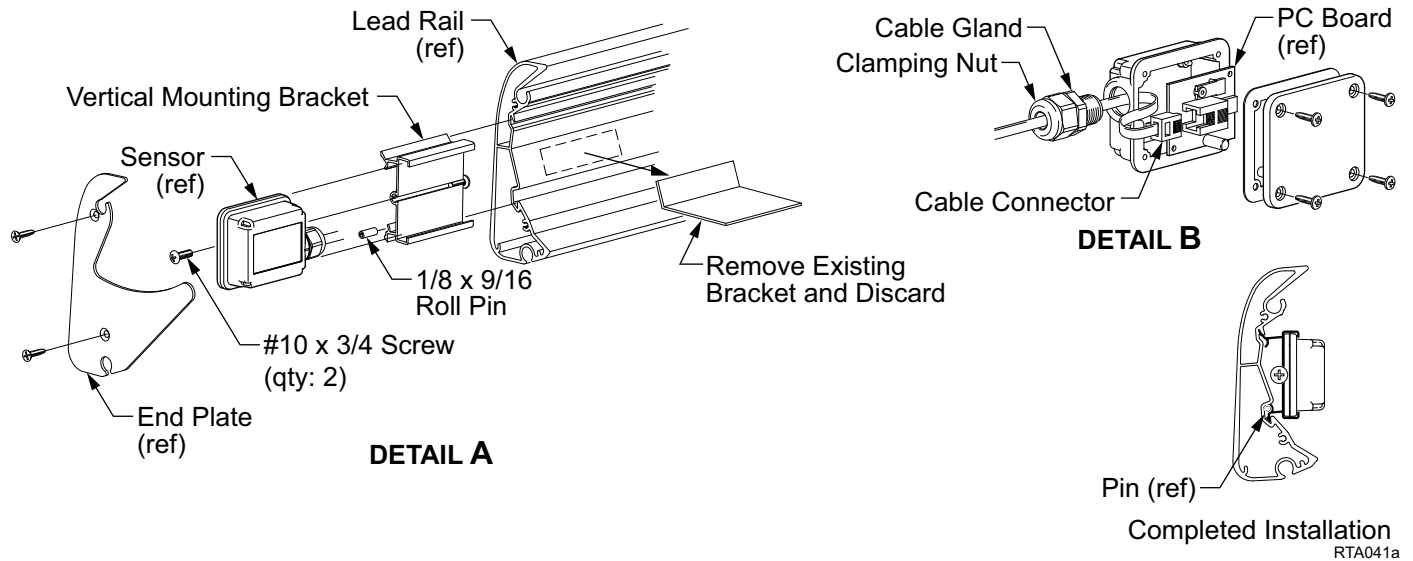

Figure 1. Replacing the Sensor.

*Installing the Vertical Mount Bracket
(Detail A)*

1. Remove the lead rail end plate and set aside.
2. Detach the existing sensor from the bracket. The sensor is attached with a strong adhesive double sided tape. It will be necessary to use a putty knife or similar tool to carefully pry the sensor off the bracket. Allow the sensor to hang from the cord. **DO NOT CUT THE SENSOR CABLE.**
3. Remove the existing mounting bracket from the lead rail. The bracket is either attached using the double sided tape or is riveted onto the inner skin of the lead rail.

NOTICE Use care to not damage the lead rail when removing the bracket. If drilling out rivets, do not allow the drill to go through the outer skin of the lead rail.

4. Use an acetone solvent and clean any glue residue from the inner surface of the lead rail. Follow the solvent manufacturer's directions.
5. The sensor is secured to the new bracket with a #10 x 3/4 screw on each side of the bracket. Insert one (1) screw into the edge of the bracket that will be pointed to the inside of the lead rail.
6. Slide the new vertical mount bracket into the grooves of the lead rail. Position in the approximate location of the old sensor.
7. Secure the bracket by pressing the 1/8 x 9/16 roll pin between the bracket and lead rail as shown.

Installing a New Sensor

The replacement sensor is furnished with a 25 foot cable. The cable is furnished in case the installed cable has been damaged or compromised.

NOTICE Do NOT attempt to cut and splice the cable. If damaged, the cable must be replaced to ensure system integrity.

REMOVING THE OLD SENSOR

(Detail B)

1. After detaching the sensor from the lead rail, loosen the clamping nut on the wire gland.
2. Unscrew the wire gland from the sensor case and slide down the wire and out of the way.
3. Remove the back of the sensor case to reveal the PC board.
4. Carefully remove the board from the case. In some instances, the board may be tacked with adhesive and must be pried out. Use care to not damage the cord or connector.
5. Disconnect the cable from the board and slip the connector out of the case. Set the old sensor parts out of the way.
6. Test the integrity (continuity) of the installed cable. Several cable testers are commercially available. If the cable is faulty, go to "Replacing a Sensor and Cable". If the cable is OK go "Installing a Sensor Only".

REPLACING A SENSOR AND CABLE

1. Remove the existing cable. Pay particular attention to the routing and attachment points of the existing cable.
2. Slide the new sensor into the vertical mounting bracket and secure with a #10 x 3/4 screw as shown.
3. Route the new cable and sensor to the control box. Arch the cable slightly at the arm joints to avoid binding.

Tip: Use a small tool, such as a flat bladed screwdriver, to gently spread open the channel then insert the cable into the channel. Do this for the entire length of the channel until the cable is fully inserted.

INSTALLING A SENSOR ONLY:

1. On the new sensor, loosen the clamping nut on the wire gland.
2. Unscrew the wire gland from the sensor case and slide down the wire.
3. Remove the back of the sensor case to reveal the PC board.
4. Carefully remove the board from the case.
5. Disconnect the cable from the board and slip the connector out of the case.
6. Slide the connector of the installed cable into the new sensor case.
7. Attach the wire gland to the case. Do not tighten the clamping nut at this time.
8. Attach the cable to the new board.
9. Reassemble the new sensor.
10. Tighten the cable gland clamping nut.
11. Slide the new sensor into the vertical mounting bracket and secure with a #10 x 3/4 screw as shown.

REPLACING THE TOUCH-PAD WITH A KEY PAD

The original touch pad control panel has been obsoleted and is replaced with a new Key Pad control panel. The new control panel provides a positive tactile feel and control of the awning(s). The Key Pad provides improved reliability and performance even after years of use.

Remove the Existing Control Pad

1. Disconnect power to the awning.
2. Locate the existing touch-pad control panel and bridge.
3. Disconnect the wires and RJ11 cable from the bridge. Set the bridge aside.
4. Remove the front cover from the touch pad assembly. It snaps off and on.
5. Rotate the touch pad board away from the mounting plate.
6. Remove the screws holding the mounting plate and pull the assembly and wires out and away from the wall and set aside, do not discard.

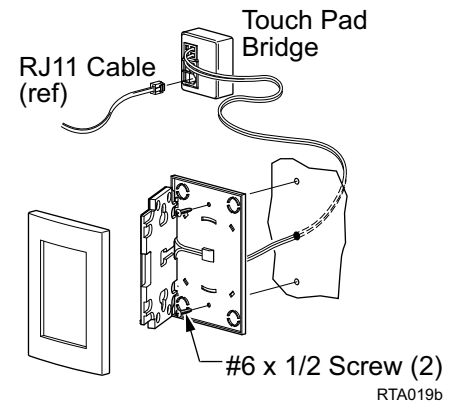

Installing the New Key Pad

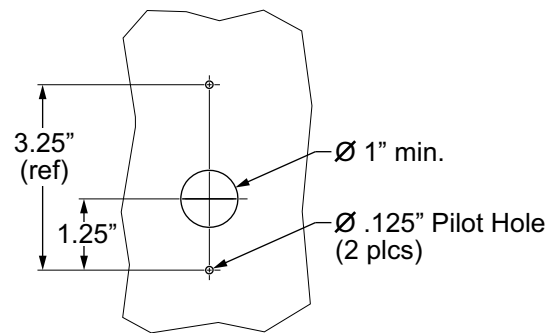
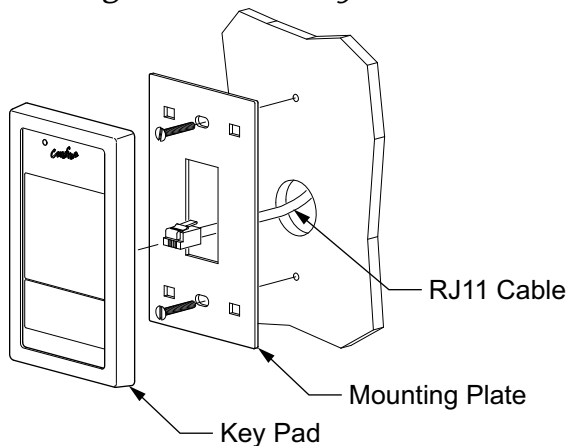

1. Locate the mounting location of the key pad. The key pad requires a flat area approximately 2 3/4" wide by 4 1/2" tall.
2. Use the mounting plate as a template and mark the location of the two mounting holes.

NOTE: The new mounting plate holes will match the mounting holes of the old touch pad.

3. Remove the plate, mark and cut a 1" hole in the position shown.
4. Mount the plate to the surface using the included screws.
5. Route the RJ11 cable, disconnected from the bridge, through the wall and mounting plate.
6. Attach the cable to the back of the key pad then attach the key pad to the mounting plate.

NOTE: The key pad attaches to the plate with magnetic latches. No additional attaching hardware is required.

ILLUSTRATED PARTS LISTINGS

SERIAL NUMBER LOCATION

Serial# / Part# Located on the Rear Outside Case on Motor Side

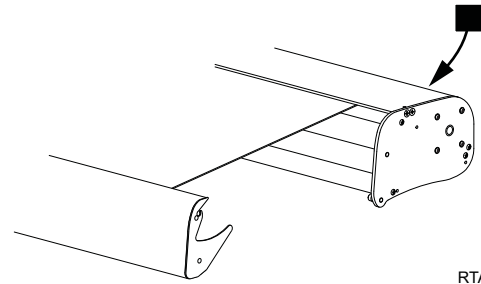

RTA048

AWNING COMPONENTS

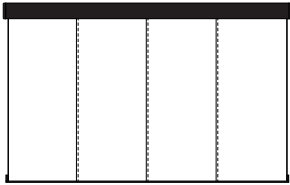

VS Configuration
Canopy construction with vertical seams (previous)

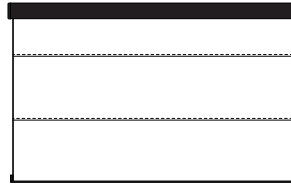

HS Configuration
Canopy construction with horizontal seams (current)

There are two configurations of the Apex based on the canopy construction as shown above.

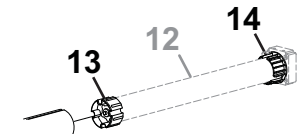

Original Motor Configuration
(Silver Body)

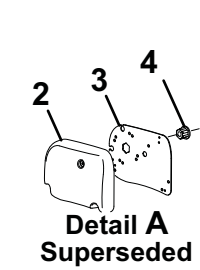

Detail A
Superseded

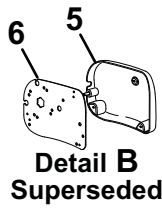

Detail B
Superseded

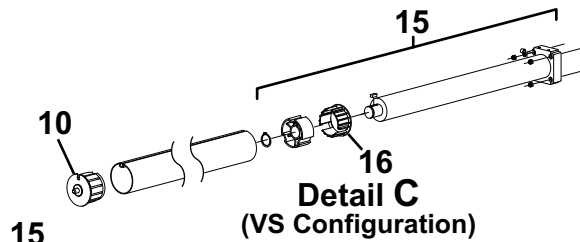

Detail C
(VS Configuration)

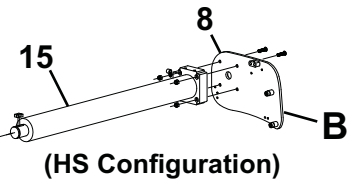

(HS Configuration)

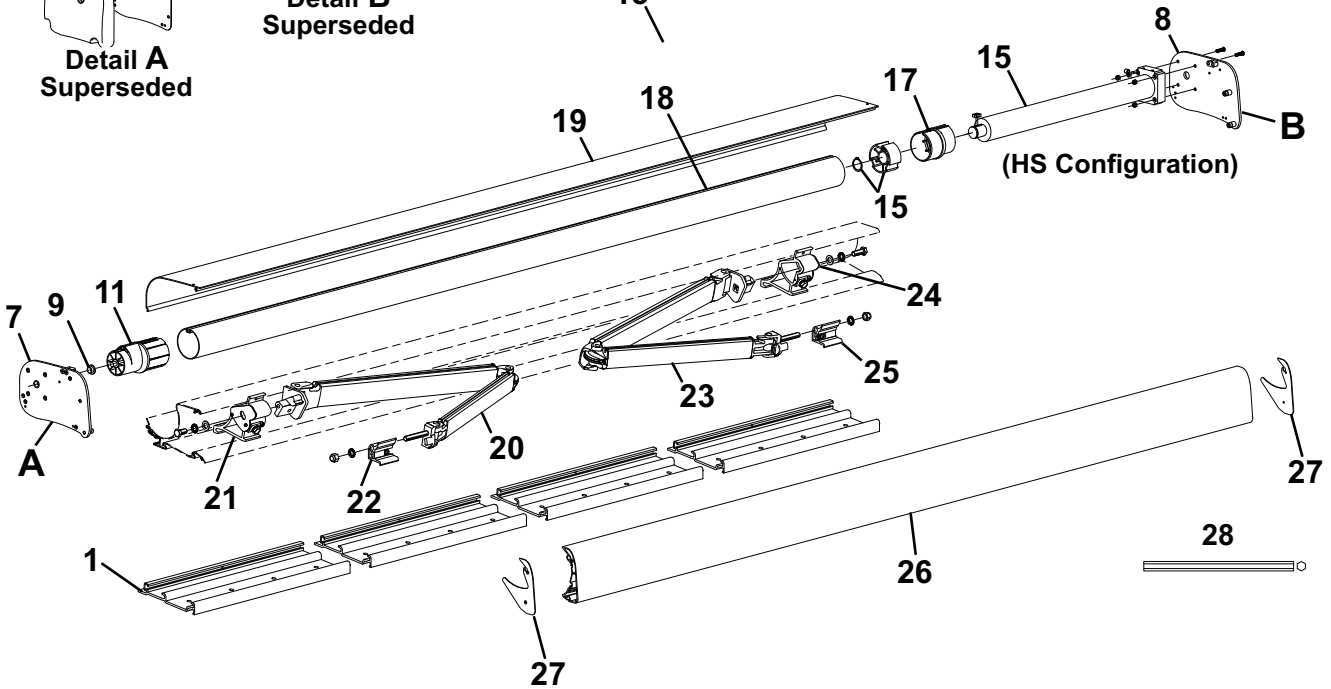

RTA501asm

Item	Part Number	Description	Notes
1	R076744-006	Mounting Plate	
2	Superseded	End Cap, LH	2
3	Superseded	End Plate, Housing, LH	2
4	R062755-001	Glide Bushing, Idler,	Used with items 8, or 9
5	Superseded	End Cap, RH	3
6	Superseded	End Plate, Housing, RH	3
7	R001190XXX	End Plate Assy, LH	
8	R001191XXX	End Plate Assy, RH	
9	R035310-002	Bushing, Idler	
10	R001054	End Plug, Idler	Used with VS Configuration
11	R041335-001	End Plug, Idler	Used with HS Configuration
12	NLA	Motor Assy, Silver Body	Discontinued FSO R001853
13	R030886-001	Drive Gear, Motor	Used with item 12
14	R030885-001	Crown, Motor	Used with item 12
15	R001853	Motor Assy, Orange Body	8
16	R041369-001	Crown, Motor	Used with VS Configuration
17	R041336-001	Crown, Motor	Used with HS Configuration
18	R001069-xxx.xx	Roller Tube	1 7/8 Dia
19	R001257XXX-xxx	Top Cover, used with RH Motor	
	R001579XXX-xxx	Top Cover, used with LH Motor	
20	R001612BLK	Spring Arm Assy, LH	5
21	R062768-001	Knuckle, LH, Spring Arm	5
22	R019263-23L	Connector, LH, Lead Rail	Black 5
23	R001614BLK	Spring Arm Assy, RH	5,6
24	R062769-001	Knuckle, RH, Spring Arm	5,6
25	R019263-23R	Connector, RH, Lead Rail	Black 5,6
26	R001516PBLK-xx	Lead Rail	
27	R036624-006	End Plate, Lead Rail	7
28	R030796-001	Hex Key, Manual Override	7mm
29		Canopy Replacement	See Canopy Order Form

- Notes:
1. XXX = Color; xxx = Length in inches.
 2. LH end plate (8) and end cap (9) is superseded. Use R001190XXX End Plate Assy (10) for replacement.
 3. RH end plate (11) and end cap (12) is superseded. Use R001191XXX End Plate Assy (13) for replacement.
 4. Glide bushing (14) used with item 11 only.
 5. Item 10 (LH Spring Arm Assy) includes items 21 and 22. Item 23 (RH Spring Arm Assy) includes items 24 and 25.
 6. For awnings 19' and longer with center arm, use RH arm (item 23 for center arm).
 7. Lead rail end plate (item 27) is universal and can be used on left or right side.
 8. Motor assembly (item 15) includes drive, crown (item 16) and attaching hardware. It does not include crown (item 17).

ELECTRONICS COMPONENTS

Single

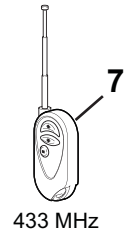
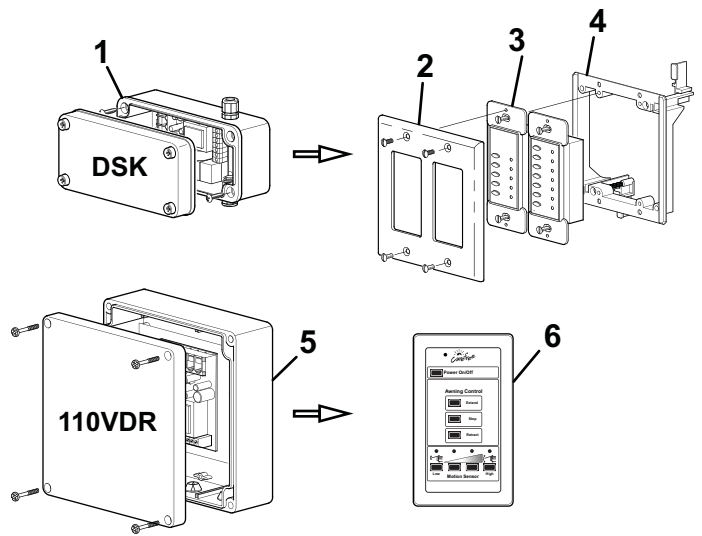

2-Awning

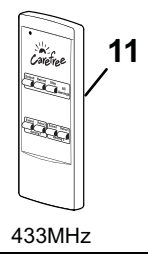
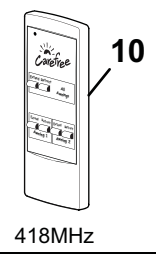
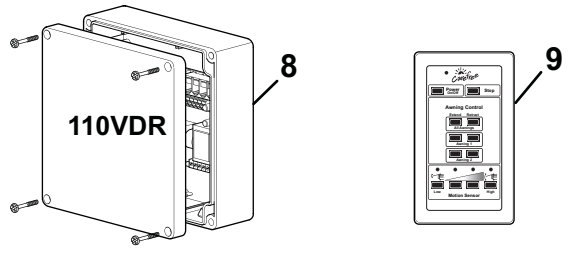

4-Awning

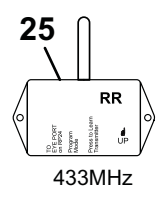
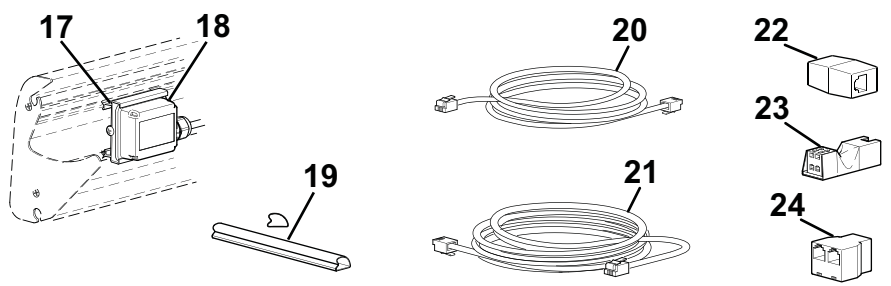
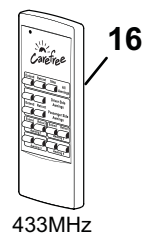
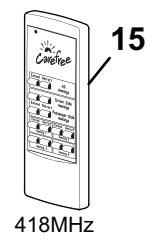
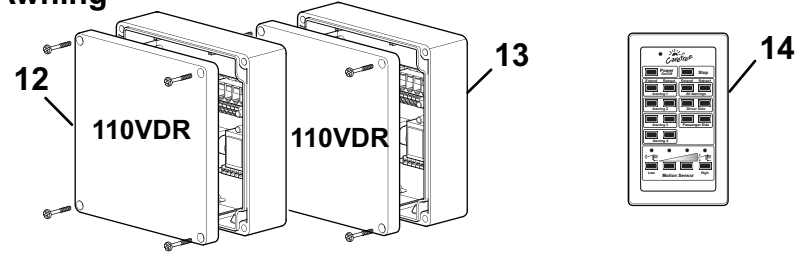

RTA501csm

<i>Item</i>	<i>Part Number</i>	<i>Description</i>		<i>Notes</i>
1	R060525-001	Control Box	DSK	Single Awning 2
2	R060535-001	Switch Plate		Single Awning 2
3	R019474-001	Switch Assy		Single Awning 2
4	R072141-001	Mounting Box, Switch		Single Awning 2
5	R060633-001	Control Box	110VDR	Single Awning 3
6	R060616-102	Key Pad		Single Awning 3
7	R060622-002	Key FOB, Remote, 433 MHZ, Version 5		Single Awning 6, 7
8	R060633-002	Control Box, Motor 1 & 2	110VDR	2-Awning 4
9	R060616-202	Key Pad		2-Awning 6, 7
10	R001391	Remote, 418 MHz		2-Awning 6, 7
11	R001393	Remote w/ Stop, 433 MHz		2-Awning 6, 7
12	R060633-002	Control Box, Motor 1 & 2	110VDR	4-Awning 4
13	R060633-004	Control Box, Motor 3 & 4	110VDR	4-Awning 6, 7
14	R060616-402	Key Pad		4-Awning 6, 7
15	R001392	Remote, 418 MHz		4-Awning 6, 7
16	R001394	Remote w/ Stop, 433 MHz		4-Awning 6, 7
17	R060538-002	Motion Sensor w/ cable		5
18	R001355	Bracket Kit, Vertical Sensor Mount, Apex		5
19	R040616-006	Cable Channel		Black
	R040616-005	Cable Channel		White
20	R060434-001	Phone Cable, 60"		
21	R060434-008	Phone Cable, 240"		
22	R060596-001	Coupler, Cable		
23	R060532-001	Ignition Lockout Sensor		
	R060532-002	Ignition Lockout Sensor, RTL		
24	R060589-001	Splitter		
25	R060429-003	RF Remote Receiver, 433 MHz, Version 5		6, 7, 8, 9

- Notes:
- Control boxes, switches and remotes are NOT interchangeable between systems.
 - Items 1 thru 4 are used for Apex single awning installations thru 2006; and for Mirage single awning installations thru 2007. DSK style switch assy (item 3) must be used with "DSK" control boxes (item 1).
 - Keypad (item 6) must be used with control box (item 5).
 - Original multiple awning installations uses a touch pad control panel. Touch pads have been superseded with a key pad control panel. For spares order item 9 for dual awnings; item 14 for 4-awning installations. Replacement instructions are found in the Apex service manual.
 - Replacement motion sensors must be mounted vertically. If replacing a horizontal mount sensor, it will be necessary to order and install R001355 bracket kit.
 - If replacing a 418MHz remotes and/or receiver marked "RR24" used for Apex thru 2006, it will be necessary to replace both the transmitter and receiver.
 - 433MHz remotes (items 7, 11, 16) and receiver (item 25) are used for Apex 2007 and on. Remote transmitter and receiver must match in frequency (433 MHz). The 433MHz receiver is marked with "RR".
 - For single awning applications, when replacing a 433MHz gray button key FOB (item 9) and/or a receiver marked "RR version 1", it will be necessary to replace both the FOB and receiver. Use items 7 and item 25 version 5.
 - Remote Receiver marked Version 5 (item 32) is compatible with all 433MHz remote marked version 2 thru 5.

For LED parts and service, refer to 070013-301 "LED Service Manual for Box Awnings" available on-line at www.carefreeofcolorado.com

COMPONENT IDENTIFICATION

Control Panel and Remotes Identification

Control Panels

Single Awning



2-Awning

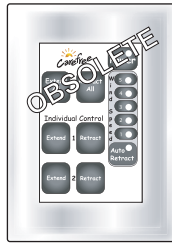

4-Awning



Series I

Multiple Awning Touch Pad Control Panels are Discontinued and Obsolete

Use Series III Key Pads for Replacements.

Single Awning DSK style Key Pads are available for Spares. CANNOT be replaced with a Series III Key Pad for single awnings.

Series I



Series II

Multiple Awning KeyPad Control Panels with "Full Time Auto-Retract" are Discontinued and Obsolete

Use Series III Key Pads for Replacements.

Single Awning DSK style Key Pads are available for Spares. CANNOT be replaced with a Series III Key Pad for single awnings.

Series II



Series III

Remotes & Receivers

FCC ID OJM-CMD-KEYX-XXX
□ 315MHz □ 418MHz □ 433MHz

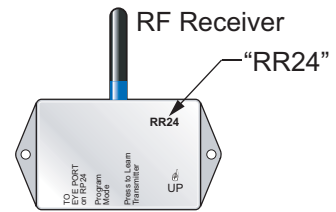

418 MHz

FCC ID OJM-CMD-KEYX-XXX
□ 315MHz □ 418MHz ■ 433MHz



433 MHz Remotes include a "STOP ALL" button

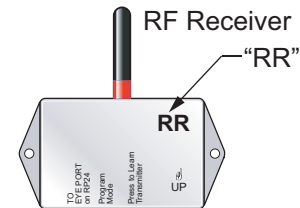

433 MHz

RR Version-1 can only be used with the 433MHz Gray Button Single Remote. All 433MHz remotes can be used with RR Version 2 thru 5.

Transmitter (remote) and receiver must have matching operating frequency.

*Control Box Enclosure Identification***ENCLOSURES**

Enclosures for the Apex control units may vary between installations. Actual installation is the same for all boxes with the noted exceptions shown below, primarily the box footprint. Wiring to the control board(s) is the same for all enclosure configurations. Boards are labeled "Motor 1", "Motor 2" etc. Multiple awning control boards are not interchangeable between boxes. Refer to the wiring diagrams starting on page .

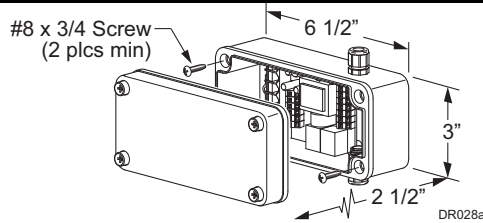
**Discontinued for RV products in 2007**

Single Awning "clam shell" style control box. Was typically used with the DSK style control switches. For replacements, use R060607-001 (UL Enclosure)

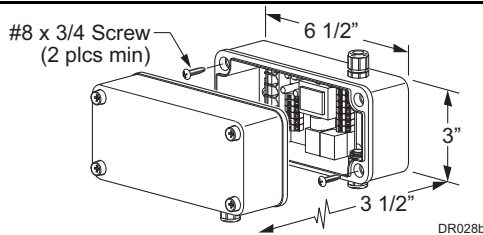
**Discontinued for RV products in 2007**

2-Awning "clam shell" style control box. Each box contains two control boards. One box is required for 2-awning configurations. Control Box is obsolete for replacements use the 2-awning 110VDR UL box.

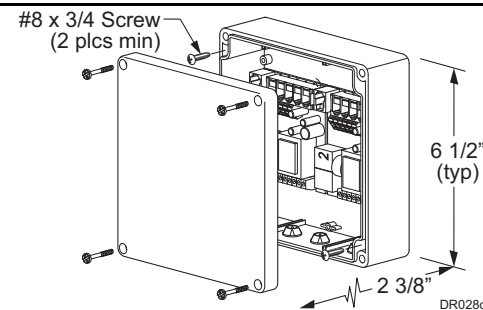
**Standard Control Enclosure (UL)**

Used for single, 2-awning and 4-awning configurations. Single awning contains one control board; 2-awning configuration contains two boards. Two boxes are required for 4-awning configurations. Boards are labeled "Motor 1", "Motor 2" etc. Multiple awning control boards are not interchangeable between boxes.

Single awning control boxes marked "110VDR" uses the keypad control panel. Single awning control boxes not marked or marked with "DSK" uses the DSK style switches.