

2-AXIS PRINTHEAD MICRO ADJUST
0.8" EACH AXIS

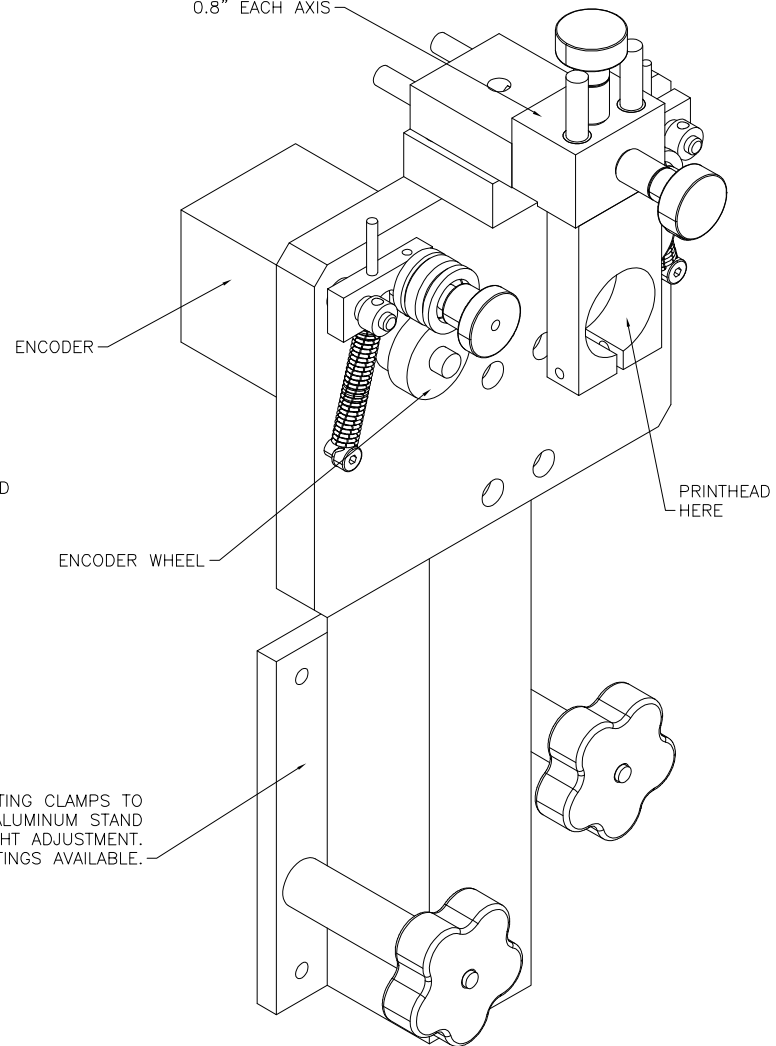

REVERSIBLE SPRING-LOADED
PINCH ROLLERS
WITH (2) GROOVE SIZES

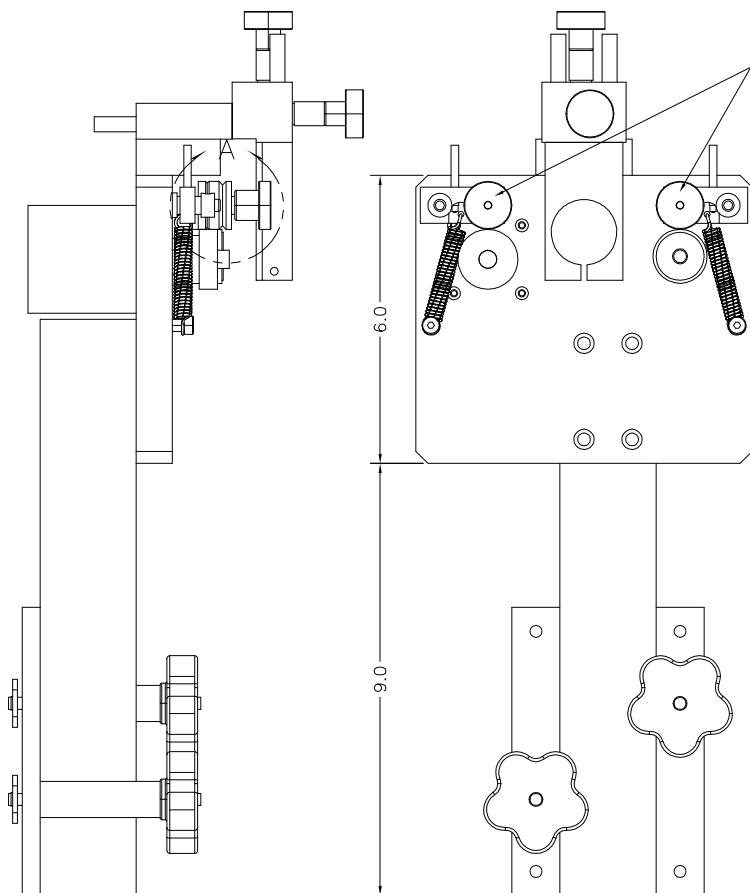

STANDARD MOUNTING CLAMPS TO
T-SLOTTED ALUMINUM STAND
FOR HEIGHT ADJUSTMENT.
OTHER MOUNTINGS AVAILABLE.

<p>Automation Plus Mechanical Division 3409 W. Harry, Wichita, Ks 67213 (316) 946-9988</p>		<small>Notice of Proprietary Property The information contained herein is the property of AUTOMATION-PLUS, INC. The possessor agrees to the following: (1) To maintain this document in confidence. (2) Not to reproduce or copy it. (3) Not to reveal or publish it in whole or part.</small>	
		DESIGN BY: _____	DATE _____
Tolerances Unless Otherwise Specified		TITLE SMALL GAUGE WIRE PRINTER 12 GAUGE AND SMALLER	
Angles € 1/2° Fractions € 1/16 .X € .1 .XX € .01 .XXX € .005 .XXXX € .0005		MATL: CUSTOMER	APPROVED BY: _____ DATE _____
		FINISH: _____ QTY: _____	JOB NO. _____ NEXT ASSY: _____ SCALE: _____ SHEET _____ OF _____ FILE NO. _____