

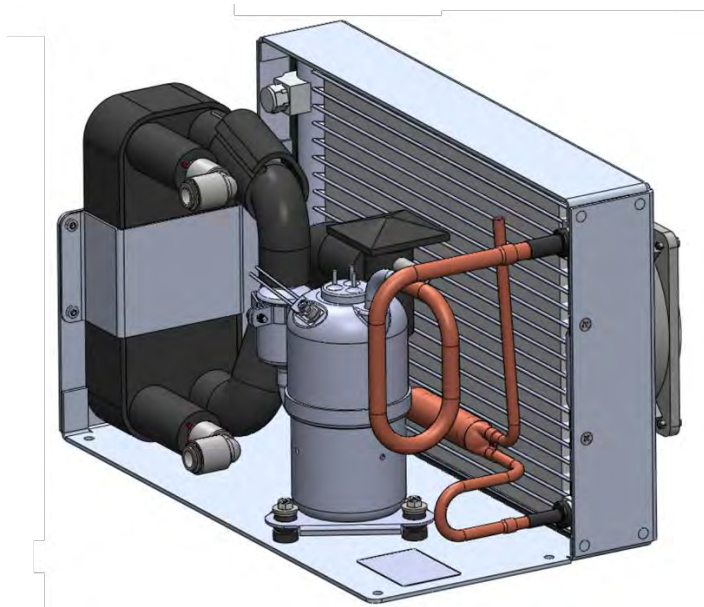

24 St. Martin Dr.
Marlborough, MA 01752

Installation and Operation Instructions

Liquid Chiller Module FP00066, FP00102



Installations Notes

Date of Purchase	
Date of Installation	
Installer	
Model Number	
Serial Number	

Contents

System Information	3
Safety	3
General Operation	4
Environmental.....	4
Condenser Fans.....	4
Fluid Connections.....	4
Mounting.....	4
Power Supply – FP00066 ONLY	6
Power Supply – FP00102 ONLY	6
Thermal Switch	6
Compressor Control	6
Performance	6
Maintenance	7
Customer Service	7
Commercial Product Warranty	7
Warranty Repairs	8
Technical Support	8
Aspen Contact Information.....	8
APPENDIX.....	8

System Information

The T-38 Liquid Chiller Module (LCM-1400) is a chassis mounted cooling system. The LCM is the core of a variable speed, vapor-compression chiller. When properly installed, the LCM uses vapor compressor technology to cool a circulating coolant. The LCM consists of a compressor (with drive board), condenser, over-pressure valve, filter dryer, expansion valve, evaporator, and fans.

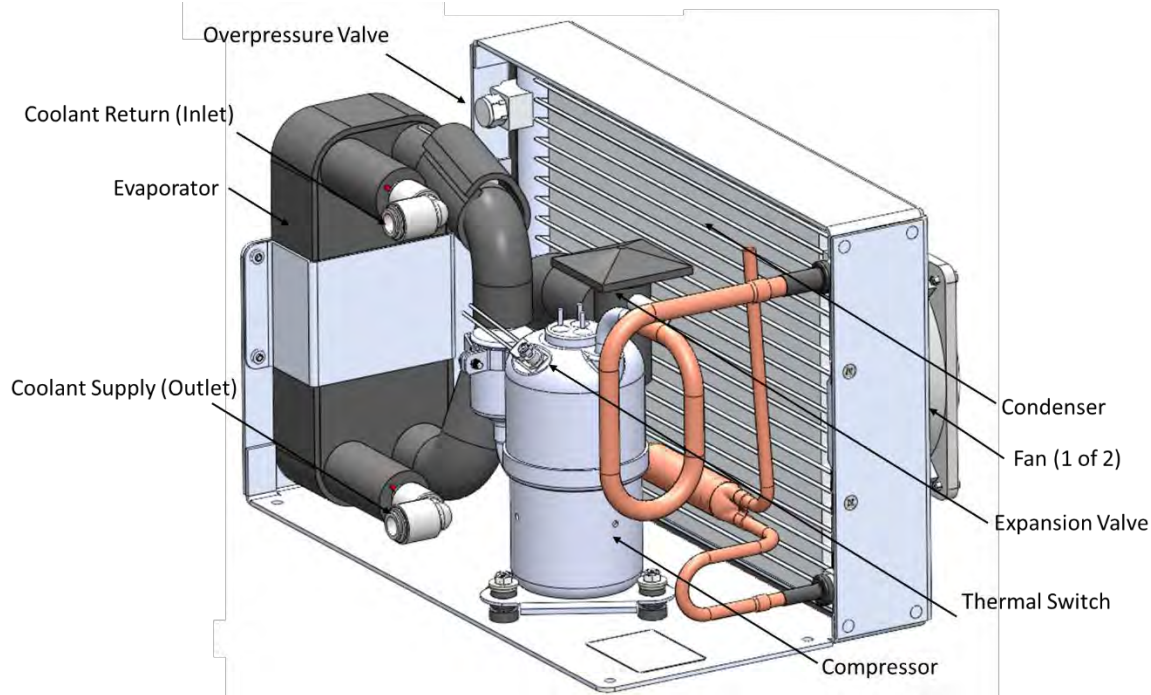

Figure 1: LCM (FP00066, FP00102) Assembly (drive board and cable not shown)

Safety

The LCM contains **Tetrafluoroethane (R-134a)** as a refrigerant. R-134a is an approved long-term replacement for CFC-based refrigerants and an approved ozone depleting substance (ODS) alternative. In the event that the LCM is damaged, general work clothing, leather gloves, and eye protection should be worn to prevent exposure to refrigerants. The LCM also contains Polyolester (POE) oil, which is used by the compressor. Contact Aspen for the MSDS for either of these internal fluids.

Precautions relating to the personnel hazards regarding contact with this substance should be outlined in training and technical manuals.

Disposal of R-134a must comply with federal, state, and local disposal or discharge laws.

WARNING! R-134A is subject to U.S. Environmental Protection Agency Clean Air Act Regulations Section 608 in 40 CFR Part 82 regarding refrigerant recycling, therefore the refrigerant must be evacuated from the LCM prior to disposal of the assembly.

CAUTION! Skin contact with refrigerant may cause frostbite.

General Operation

Environmental

Coolant	Water, Glycol/Water Mixtures (contact Aspen for use of other coolants)
Ambient (Operation)	-20°C to 50°C (32°F – 122°F)
Ambient (Storage)	-20°C to 50°C (-4°F – 122°F)
Weight	5.4 kg (12 lb)
Size	19.1 x 22.4 x 13.7 cm (7.6 x 8.8 x 5.4 in)

Condenser Fans

To operate properly, airflow must be provided to the condenser **prior to turning the compressor on**. Two fans are attached to the condenser, which requires a 48 VDC (FP00066) or 24 VDC (FP00102) power supply. The provided fans each generates 138 cfm (without restriction). Aspen Systems does NOT recommend using the available voltage output on the compressor drive board to operate the fan. Please connect the fan directly to a 24 VDC supply (FP00066) or 48 VDC supply (FP00102). See Figure 2 for airflow direction.

Fluid Connections

The LCM terminates with 3/8 inch John Guest push-to-connect (Speedfit) fittings. The user must adapt their cooling loop to these fittings. These fittings are rated to 140 psig with suitable tubing.

Provided Fittings: John Guest Superseal Speedfit: SI031212S

A customer supplied coolant pump must be used to generate coolant flow across the evaporator. In order to achieve the maximum performance from the system, proper insulation of the coolant lines may be required.

CAUTION! When using a water-based coolant, care must be taken to avoid freezing in the evaporator. THE LCM IS CAPABLE OF FREEZING WATER WITHIN THE EVAPORATOR IN LESS THAN 1 MINUTE IF WATER FLOW STOPS OR SLOWS WHILE THE LCM CONTINUES TO RUN. Freezing the evaporator could rupture the evaporator causing a water and/or refrigerant leak.

Mounting

The LCM is supplied on an 0.063 inch thick aluminum base plate. There are four #10 clearance holes (0.221 inch diameter) that can be used to hold down the LCM. See drawing (Figure 2) for hole locations and full outer dimensions. Insulation and screw heads may protrude beyond the defined overall geometry. Contact Aspen directly if a solid model is required.

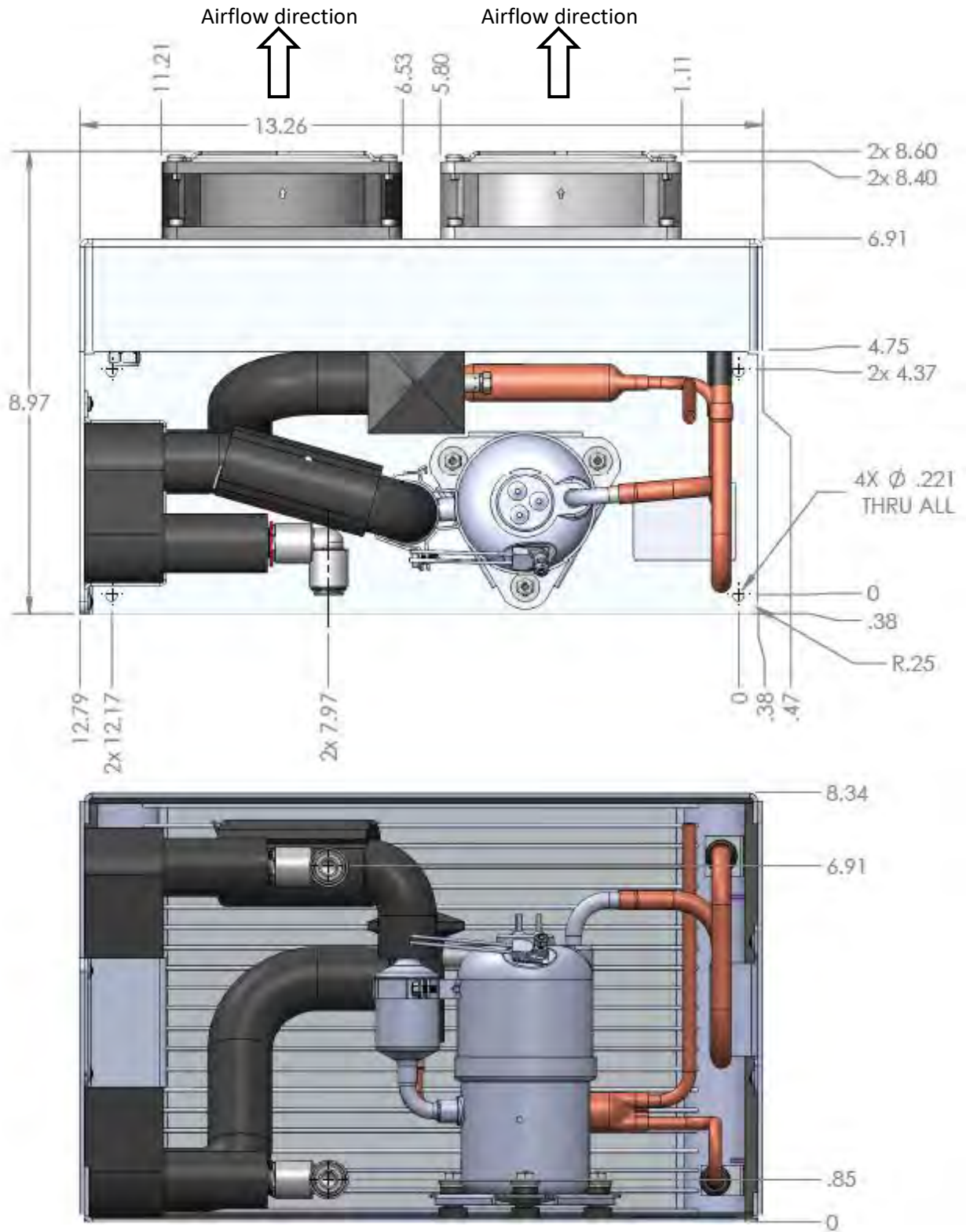

Figure 2: LCM Dimensional Drawing - Note all dimensions are in inches

CAUTION! The LCM must be operated in the vertical orientation. Operation of the system at an orientation of >30° from vertical may result in reduced system capacity or damage to the compressor.

Power Supply – FP00066 ONLY

The motor drive board PCB shipped with the LCM is a 48 VDC unit. The operating voltage range is 43 VDC – 50 VDC. The LCM may draw up to 10.5 A of current during normal operation (compressor and fans combined). Aspen recommends at least 16 AWG wire for the power supply to the compressor drive board with an in-line 10 A fuse (see Appendix page 1)

CAUTION! Operating the LCM outside the voltage range will void the system warranty.

Power Supply – FP00102 ONLY

The motor drive board PCB shipped with the LCM is a 24 VDC unit. The operating voltage range is 22 VDC – 30 VDC. The LCM may draw up to 16 A of current during normal operation (compressor and fans combined). Aspen recommends at least 12 AWG wire for the power supply to the compressor drive board with an in-line 15 A fuse (see Appendix page 1)

CAUTION! Operating the LCM outside the voltage range will void the system warranty.

Thermal Switch

The LCM is provided with a thermal switch attached to the top of the compressor. This thermal switch provides protection for the compressor to prevent overheating in the case of a failure condition (e.g. blocked air, failed fan, elevated ambient temperature, etc). This thermal switch shall be connected to the overheat tab (TB11) and the ground tab (TB9).

CAUTION! Operating the LCM without the thermal switch connected will void the system warranty.

Compressor Control

Please refer to the **Aspen Compressor Low Noise / Low Vibration Sinusoidal BLDC Drive** manual (see appendix) for detailed wiring and functionality of the drive board. Use the included three-conductor harness to connect the drive to the compressor.

The motor drive board is a variable speed drive. This allows the cooling capacity of the system to be adjusted by increasing or decreasing the compressor speed. The compressor drive board can use one of four different speed input signals: 0 – 5 V analog voltage, 0 – 10 VDC analog voltage, 4 – 20 mA, and frequency (see Appendix section 8). The firmware has a minimum speed of 1200 RPM (condition-dependent) and a maximum speed of 6500 RPM.

Performance

The performance curve below (Figure 3) defines the performance of the LCM. The data shown below is derived using 2 L/min water flow and a 30% glycol solution for subzero operation.

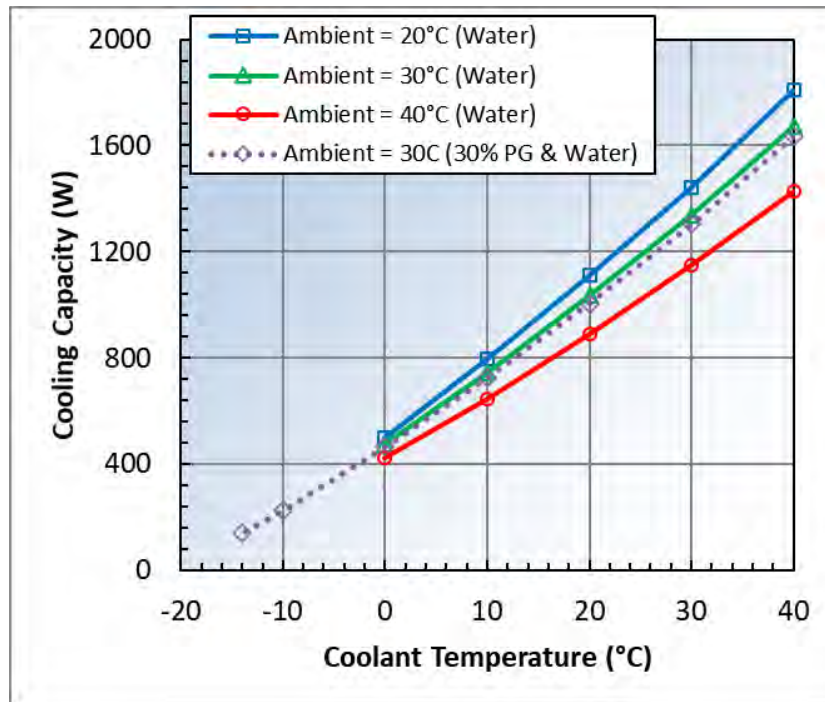

Figure 3: LCM Performance Map

Maintenance

The LCM is a sealed unit and does not require regular maintenance to operate. Depending on environmental conditions the condenser fins could become fouled with dust and debris. A fouled condenser will cause the LCM to operate inefficiently and potentially over-heat and shut down. To clean the condenser, follow the steps below. All work should be performed while wearing safety glasses and ear protection with the LCM powered off.

1. Use a damp (water), lint free towel and wipe the inner face of the condenser. Be careful not to bend or damage any of the fins.
2. Alternatively, the user may remove the fan and air may be blown through the condenser to remove any dust. Use a compressed air source regulated to between 50 and 100 psi and keep the nozzle at least 2 inches away from the condenser face. Be sure to reattach the fan and fan guard when finished cleaning the coils.

CAUTION! Directing airflow at the condenser fins at an angle may result in bending/damage of the LCM fins, resulting in decreased condenser performance.

Customer Service

Commercial Product Warranty

Aspen System LLC (hereinafter referred to as “Aspen”), warrants to the original purchaser that products sold shall be free from defects in material and workmanship for the warranty period not to exceed one year from the date of shipment. If buyer claims that a product violates such warranty, Aspen, upon notice promptly given, will either examine the product at buyer’s site, or issue shipping instructions for return to Aspen at buyer’s expense, transportation charges prepaid.

Aspen's sole obligation under its warranty shall be, at its option, to repair, replace or refund the price of any product thereof which is proved to violate such warranty. In no event, whether based on contract, indemnity, warranty, tort (including negligence), strict liability or otherwise, shall Aspen be liable to the buyer for special, indirect, incidental or consequential damages whatsoever including, without limitation, loss of profit or revenue.

The above warranty is buyer's exclusive remedy and Aspen hereby expressly disclaims all other warranties, express or implied, including the implied warranty of merchantability and the implied warranty of fitness for a particular purpose. The foregoing shall constitute the sole remedy of the buyer and the sole liability of Aspen.

This Limited Warranty shall not apply to any product or component thereof which has been repaired or altered outside of Aspen's factory in any manner so as, in Aspen's sole judgment, to affect its serviceability, or to any product that has been subject to alteration, accident, misuse, abuse, neglect or normal wear. The Limited Warranty shall not apply to products which have been assembled or installed or used in a manner contrary to Aspen's printed instructions, or due to failure to follow Aspen printed instructions for operation and maintenance. This product is designed and intended to be installed and operated in an enclosure that is sealed from the ambient environment. Exposure to water leakage into the enclosure and/or excessive condensation from exposure to humid ambient air during operation will void this warranty. Any technical assistance provided by Aspen's personnel or representatives in system design is construed to be a proposal and not a recommendation. The responsibility for determining feasibility rests with the user and should be subject to test. Only the terms expressed in this Limited Warranty shall apply and no distributor, corporation or individual is authorized to amend, modify or extend this warranty in any way on resale.

Warranty Repairs

Any product returned and found to be under warranty will be repaired or replaced at the discretion of Aspen Systems, LLC. Depending on the circumstances of the problem, it may be deemed necessary to return the products to Aspen Systems for repair. In order to return the product for repair, please contact Aspen Systems via email, telephone, or through the Aspen Systems' website (see Contact Information)

Technical Support

Technical Support is available from Aspen Systems from 8:00 AM to 5:00 PM (EST) Monday through Friday via phone or email (see contact information). Technical support can also be requested on-line. To expedite assistance for problems, be able to provide the following information:

- Your name, phone number, company, division and city.
- Product number, serial number and revision (located on the LCM evaporator bracket).
- A detailed description of your problem.

Aspen Contact Information

Email: info@aspensystems.com

Phone: 508-281-5322

Website: <http://aspensystems.com/contact>

APPENDIX

Wiring & Operating Instructions

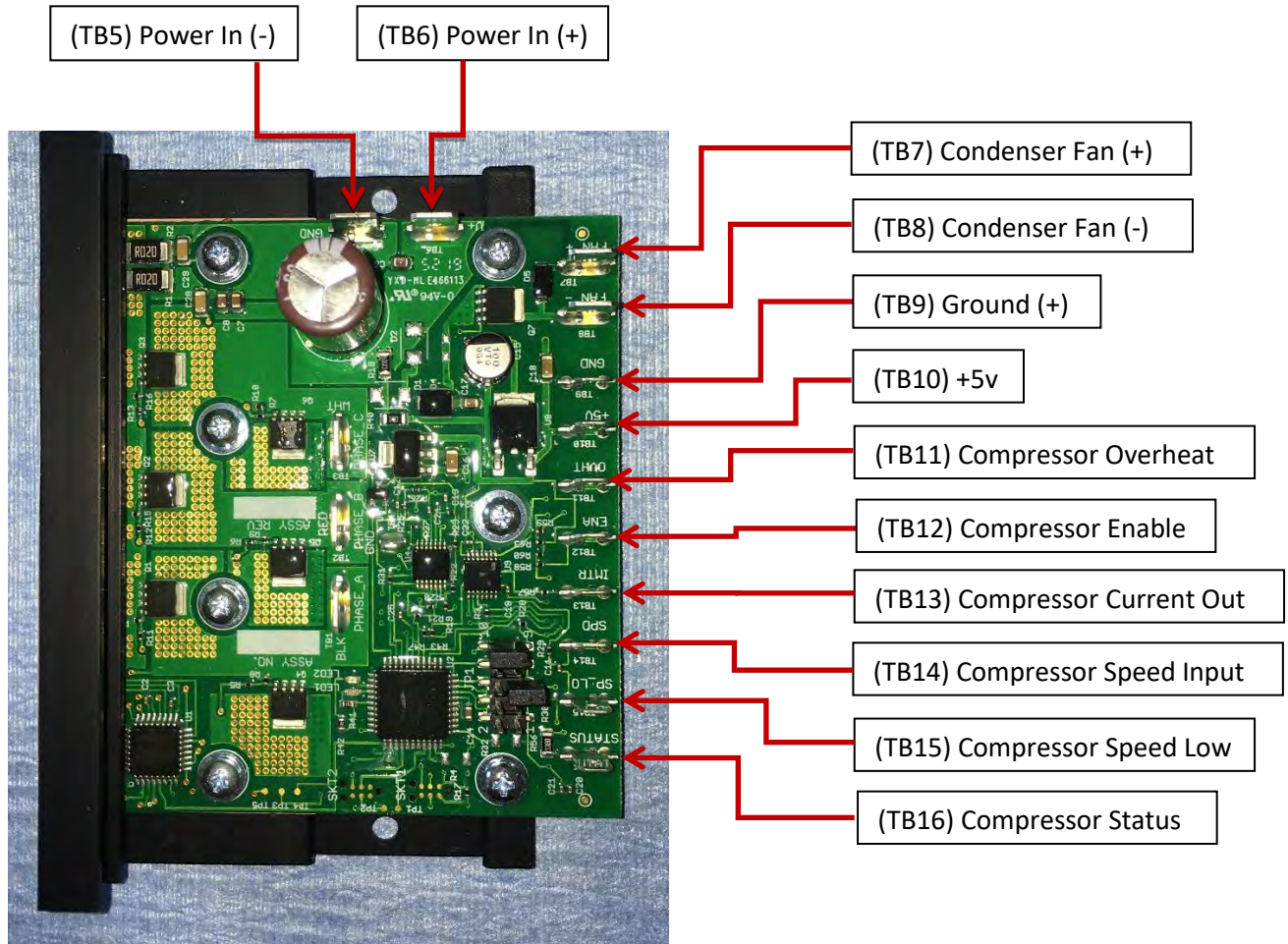

1. Power Supply Input (TB5 & TB6)

Aspen's Twin Compressor Sinusoidal Low Noise/Low Vibration Drive is available in 2 voltages, 24 and 48 volts.

The connections to the drive board power input are two .250" faston tabs.

The use of adequate wire gage and an inline fuse for short circuit protection is highly recommended.

The table below shows the recommended wire gage and fuse size for each of the Aspen drives

Drive Board	Operating Voltage Range	Recommend Wire AWG	Recommended Fuse
24 Volt	20-30 Volts	12	15A (Littlefuse 0312015)
48 Volt	43-50 Volts	16	8A/10A (Littlefuse 0312010)

2. Condenser Fan Output (TB7 & TB8)

An output has been provided for running condenser fan(s) from the Aspen drive. The voltage of this output will be equivalent to the DC input voltage provided to the board. The power to the condenser fan is enabled 10 seconds after the drive starts the compressor. Therefore, when the compressor is off, the power to the condenser fan(s) is off. When the compressor is signaled to run, the power to the condenser fan(s) will be enabled 10 seconds after the compressor has started running. This 10 second delay is intentional and is meant to reduce the total amount of inrush current when the compressor starts. The connections to the condenser fan outputs are two .250" faston tabs. The condenser fan output should be limited to a maximum of 5 amps on 12/24 volts boards and 3 amps on 48 volt boards.

3. Ground (TB9)

The ground tab is for connecting both the compressor enable and compressor over temp connections to. Both the compressor enable and the compressor overheat connections must be connected to ground in order for the compressor to operate. The connection to the ground is a .187" faston tab.

4. +5V (TB10)

The +5v tab is provided to give the user the ability to provide a low voltage speed signal input without the use of an additional power supply. The 5 volts can be wired directly to the speed input tab, which will cause the compressor to operate at full speed, or can be wired to a 20k potentiometer to allow the user to vary the voltage to the speed input tab and vary the speed of the compressor. The connection to the +5v is a .187" faston tab.

5. Compressor Overheat (TB11)

In order for the compressor to operate, the overheat tab connection must either be connected directly to ground, or connected to an optional thermal safety switch, which is then connected to ground. When used in conjunction with the thermal switch, the drive will shut the compressor off when the thermal switch indicates that the compressor has overheated. Once this has occurred, the board will flash the red LED a sequence of 16 flashes to indicate that the compressor has overheated. To restart the compressor, the thermal switch must reset and the user must either cycle the main power on the drive board or momentarily disconnect the enable wire from ground. The connection to the compressor overheat is a .187" faston tab.

6. Compressor Enable (TB12)

In order for the compressor to operate, the compressor enable tab connection must be connected to ground. This connection can also be wired through a thermostat and then to ground to cycle the compressor on and off via a thermostat. The connection to the compressor enable is a .187" faston tab.

7. Compressor Current Out (TB13)

The drive is equipped with a current out connection to allow the user to monitor the current consumption of the compressor. The current out connection puts out a voltage that correlates to the current being used by the compressor only and not the condenser fans if they are so attached. The correlation is .1 volts per amp, so if the compressor is using 5 amps of power, the voltage measure on the current out tab will be .5 volts. The connection to the compressor current out is a .187" faston tab.



8. Compressor Speed Input (TB14)

There are 4 different options for speed input. The chart below shows the different inputs and speed scaling relationship.

input	RPM/serial	5 Volt	10 volt	4-20 mA	freq
drop out	1200	0.66	1.32	6.11	33
pick up	1400	0.80	1.60	6.56	39
full speed	6500	4.50	9.00	18.40	180

Speed Range - The compressor has the ability to control speed from 1200-6500 RPM's. The compressor will only reduce speed below 2000 RPM's when the compressor current is below a stable operating threshold. This is done to increase operational reliability and prevent the compressor from stalling at very low operating speeds.

Option 1 (0-5v input) - The compressor speed input accepts a 0-5 vdc analog voltage signal and will regulate the speed of the compressor automatically with respect to this input voltage. The compressor will turn on once the input voltage has reached ~.8 volts and off once the input voltage has dropped below .66 volts. There will be a linear increase in speed from the turn on voltage of .8 volts (~1400 rpm) through the max speed voltage of 4.5 volts (~6500 rpm). There is no addition increase in speed between 4.5-5 volts. The connection to the compressor speed input is a .187" faston tab.

Option 2 (0-10 v input) - The compressor speed input accepts a 0-10 vdc analog voltage signal and will regulate the speed of the compressor automatically with respect to this input voltage. The compressor will turn on once the input voltage has reached ~1.6 volts and off once the input voltage has dropped below 1.32 volts. There will be a linear increase in speed from the turn on voltage of 1.6 volts (~1400 rpm) through the max speed voltage of 9 volts (~6500 rpm). There is no addition increase in speed between 9-10 volts. The connection to the compressor speed input is a .187" faston tab.

Option 3 (4-20mA input) - The compressor speed input accepts a 4=20mA input signal. The compressor will turn on once the input current reaches 6.56 mA and off once the current drops below 6.11 mA. There will be a linear increase in speed from the turn on current of 6.56 mA (~1400 rpm) through the max speed current of 18.4mA (~6500 rpm). There is no addition increase in speed between 18.4-20mA. The connection to the compressor speed input is a .187" faston tab. This signal carries a maximum voltage rating of 10 volts.

Option 4 (Frequency input) - The compressor speed input accepts a frequency input signal. The frequency signal should be a 5 VDC, 50% duty cycle, square wave. The compressor will turn on once the input frequency rises above 39Hz and off when the frequency drops below 33Hz. There will be a linear increase in speed from the 39Hz turn on (~1400 rpm) through the max speed of 180Hz (~6500 rpm). There is no addition increase in speed above 180Hz. The connection to the compressor speed input is a .187" faston tab.

To select the appropriate speed input, please refer to the DIP selection chart later in this document.

9. **Compressor Speed Low (TB15)**

This tab should be used when a secondary power supply is being used to supply power for speed control and the user wants the secondary supply to be isolated from the power supply being used to power the drive. In this case the factory installed jumper should be removed. This will decouple the board ground reference from the speed signal to allow for minor voltage differences between the power supply grounds. The common mode range is -1.0 to +1.0V. The secondary power supply for speed control can then be wired between the speed input and speed low connections to vary compressor speed. The connection to the compressor speed low is a .187" faston tab. See the jumper configuration table at the end of this section for details.

10. **Compressor Status (TB16)**

This tab is available to the end user so that they can monitor the normal operation of the compressor. When speed signal is being sent to the drive and the compressor is operating normally, there will be no voltage on this connection. However, if a speed signal is present and the compressor enable is satisfied but the compressor is not running, 5 volts will be present on this tab. This 5v signal can be monitored to alert the end user that there is a problem with the system and that the compressor is not running.

Additional Board Functions

1. **Compressor Start Delay** – The Aspen high capacity drive has the ability to delay the compressor start in situations where starting may be difficult due to an unbalanced system. The logic behind the delay is based on a minimum off time for the compressor and can be enabled by installing jumpers per the table at the end of this section. When activated the controller keeps track of how long the compressor has been turned off before trying to restart. If the compressor has been off for the minimum amount of time set by the dip switch when there is a call to restart, it will start immediately. If the minimum amount of time has not passed, the compressor will wait until the minimum time has been reached before attempting to start.
2. **Board Overheat** – The Aspen high capacity drive has an onboard thermistor that enables the drive to prevent itself from overheating. When the board detects that it has overheated, the drive will stop the compressor and emit a series of 8 flashes on the red LED.
3. **Automatic Current Limiting** – The Aspen high capacity drive has the ability to regulate the amount of current being used by the compressor. While the 24V drive has a 15 amp limit, the 48V drive has two limits for the current control. One is 10 amps and the other one is 8 amps and can be set by the dip switch in the table at the end of this section. The drive will automatically monitor the current consumption of the compressor. If the compressor begins to draw more than the maximum set current, the drive will automatically decrease the speed of the compressor in an effort to reduce the current being used. Once the speed of the compressor has been reduced below the minimum compressor speed, the drive will stop the compressor and flash the red LED continuously to allow the user to know



that the compressor has stalled from excessive current draw or a lock rotor condition. It should be noted that the automatic current limit only reduces the current used by the compressor and does not account for any current that may be drawn by the use of the condenser fan output.

4. **Low Speed Stall Protection** – The Aspen high capacity drive allows the compressor a speed range of 1200-6500 RPM's. The drive will only allow the compressor to operate at speeds below 2000 rpm's when the current is below a reliable operating threshold. If the current is not below a reliable operating threshold, the compressor will increase speed automatically between 1200 and 2000 to maintain operational reliability at the lowest possible speed, while preventing the compressor from stalling.
5. **Lock Rotor Protection** - The Aspen high capacity drive has the ability to detect if the compressor is not running due to a lock rotor condition. After the drive has made several unsuccessful attempts to start the compressor, the drive will stop attempting to start the compressor and flash the red LED continuously to allow the user to know that the compressor has stalled from excessive current draw or a lock rotor condition.
6. **Error Clearing** – The drive can go in to error mode for several reasons in which case the compressor will stop running. To clear the error and restart the compressor, the enable wire must be disconnected and then reconnected to ground. For a list of error conditions, see the error code table at the end of this section.

Compressor Wiring – The Aspen high capacity drive is supplied with a cable to attach the drive to the compressor. All other wiring is to be supplied by the end user. It is important to wire the compressor to the drive with the colors coded in the order per the picture below. If the order of the wires is not correct, the compressor will not operate properly.

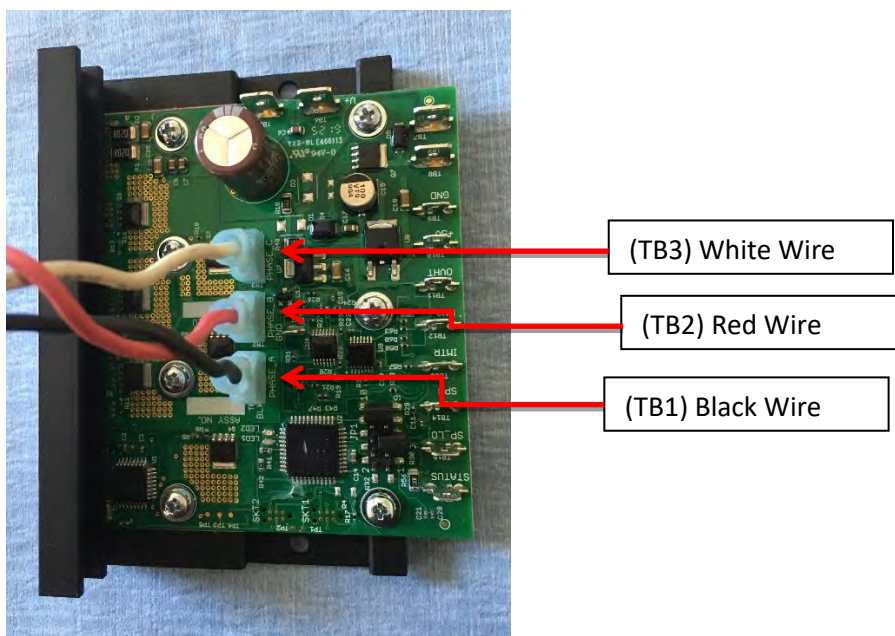

ASPEN COMPRESSOR

Low Noise / Low Vibration Sinusoidal BLDC Drive



Dip Switch Configuration – There are 5 jumpers that can be adjusted to change the configuration of the drive. The tables below provide detailed information on how to configure the jumpers.



Jumper Position	Function	Installed	Not Installed
5	Speed Low Isolation	Not Isolated (Factory Default)	Isolated
4	Speed Input	See Table Below	See Table Below
3	Speed Input	See Table Below	See Table Below
2	Start Delay	30 Seconds	None (Factory Default)
1	N/A	N/A	N/A

Speed Input	Jumper 3	Jumper 4
0-5v (Factory Default)	Not Installed	Not Installed
0-10v	Not Installed	Installed
4-20mA	Installed	Not Installed
Frequency	Installed	Installed

Troubleshooting Guide		
Symptom	Possible Cause	Remedy
Compressor will not run when speed input voltage is applied.	<ol style="list-style-type: none"> 1. Enable connection and or compressor overheat connection is not connected to ground. 2. Speed input voltage is less than (.7) volts. 3. Loose wire or connection 4. Power supply too small, voltage dropping at compressor startup. 5. Compressor is in lock rotor condition 	<ol style="list-style-type: none"> 1. Verify enable and overheat connections. 2. Verify speed input voltage to be greater than (.7) volts. 3. When speed input voltage is applied, verify green light changes from slow flashing (1x/sec) to fast flashing (5x/sec) 4. Verify all connections between compressor and drive are in place and in the proper order. 5. Measure input voltage to drive board and verify voltage is not dropping below minimum supply voltage when compressor is trying to start.

ASPEN COMPRESSOR

Low Noise / Low Vibration Sinusoidal BLDC Drive



		6. Check drive for flashing red light. If red light is flashing, check error code table for appropriate code.
Compressor turns off intermittently.	<ol style="list-style-type: none"> 1. Compressor overheating 2. Drive board overheating 3. Loose wire or connection 4. Inadequate power supply 	<ol style="list-style-type: none"> 1. Check drive for flashing red light. If red light is flashing, check error code table for appropriate code. 2. Verify all wiring connections 3. Verify compressor is not drawing more power than power supply can deliver.
Compressor speed ramps up and down automatically	<ol style="list-style-type: none"> 1. Drive board in current limiting mode 2. Drive board close to overheating 	1. Check drive for flashing red light. If red/green light is flashing, check error code table for appropriate code.
Compressor Overheating	<ol style="list-style-type: none"> 1. Ambient temperature too high 2. Inadequate airflow over compressor 3. Return gas temperature too high 	<ol style="list-style-type: none"> 1. Increase airflow over compressor 2. Verify superheat to be between recommended 8-12 deg. F.
Compressor Current Limiting	<ol style="list-style-type: none"> 1. Condensing pressure too high. 2. Liquid refrigerant being returned to the compressor. 	<ol style="list-style-type: none"> 1. Reduce condensing temperature / pressure. 2. Verify superheat to be between recommended 8-12 deg. F.

Drive LED / Error Code Table	Red LED	Green LED
Normal Operation (Compressor not running)		Slow Flash ~ 1x/sec
Normal Operation (Compressor Running)		Fast Flash ~ 5x/sec
Fault Occurring	Fast Flash ~ 5x/sec	Fast Flash ~ 5x/sec
Compressor stall / lock rotor	1 Flash Repeating	
Supply voltage too high	2 Flashes Repeating	
Supply voltage too low	4 Flashes Repeating	
Board overheated	8 Flashes Repeating	
Compressor overheated	16 Flashes Repeating	



Aspen Compressor, LLC 24 St. Martin Drive, Marlborough, MA 01752 ☎ 508-281-5322 📠 508-281-5323

web: www.aspencompressor.com

email: info@aspencompressor.com

Mounting Diagram

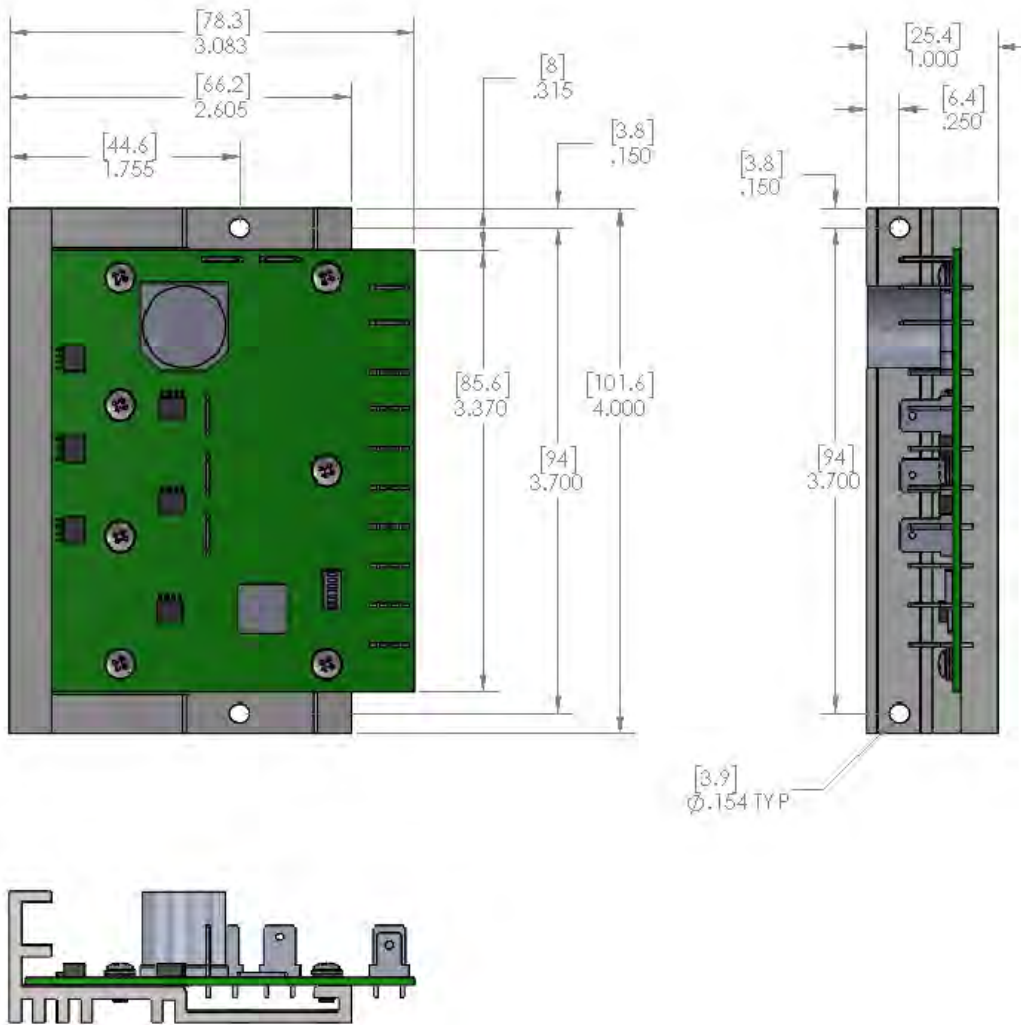

Typical Wiring Diagram

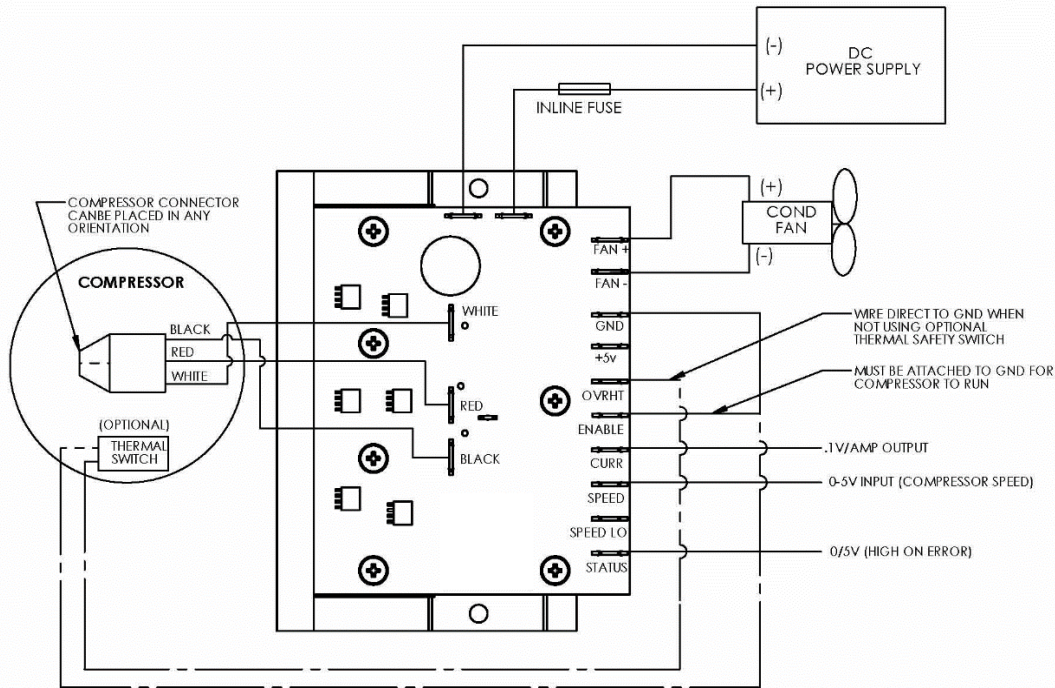

Wiring with user supplied speed input voltage

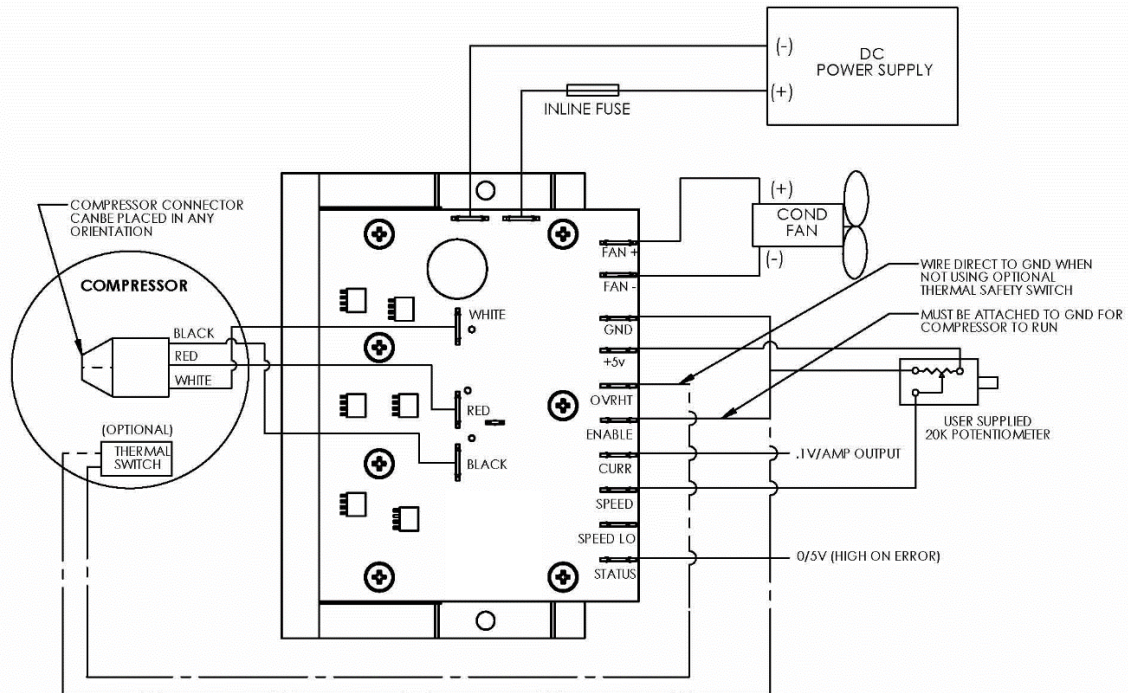

Wiring with user supplied 20k potentiometer