



ATD-6900

9 Pc. HVLP Spray Gun Set Owner's Manual



Read this manual carefully and understand it completely.
Retain manual for future use.

Always follow safety precautions to prevent personal injury and/or damage to the equipment.

Illustrations and photos are intended for reference only. Actual product may vary.
Specifications are subject to change without notice.

Important Safety Instructions

1. Always wear eye protection, gloves and respirator to prevent against harmful vapors while spraying.
2. Never use oxygen or any other combustible or bottle gas as a propellant. Explosion and serious injury or death may result.
3. Many paints and solvents can be highly flammable. Please use the spray gun only on well-ventilated areas, do not smoke or use near open flame.
4. Always disconnect the paint gun from air supply when not in use and during maintenance.
For emergency stopping and to prevent unintended operation, a valve near the gun is recommended.
5. Inspect the tool before each use to ensure there is no leakage or misaligned parts.
Be sure the trigger moves freely.
6. Never use halogenated hydrocarbon solvent, as it can chemically react with aluminum and zinc parts of this tool.
7. Do not make any modifications to this tool.



WARNING



WARNING: This product contains chemicals, including lead, known to the State of California to cause cancer, birth defects or other reproductive harm. **Wash hands after handling.**

Made in China to ATD Tools, Inc. Specifications
Visit us at www.atdtools.com

Figure 1:

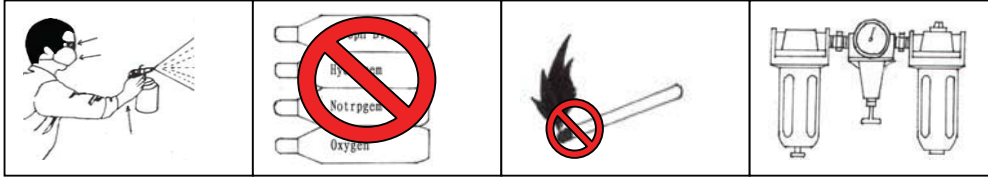

Operating Instructions

POWER SOURCE

This tool operates best on a clean, dry supply of compressed air delivered at 29 to 50 psi. Use of a moisture trapping air filter (ATD-7812) is highly recommended as moisture or foreign matter can damage the internal parts of this tool.

CAUTION: All air pressure in the system should be rated at 29 to 50 psi. Higher or lower pressure can adversely influence the operation or cause damage to this tool.

NOTE: To maintain 10 psi at the nozzle, use a minimum of 29 psi at the inlet.

TOOL PREPERATION

1. Check tool for worn or damaged parts. Repair or replace as necessary.
2. Check trigger to ensure that it moves freely.
3. Connect tool to air supply.
4. Adjust air pressure based on paint viscosity and paint manufacturer's recommendation. (fig 2)
5. Clean paint guns before use, to ensure any factory oils or pigments are not present. Do not use halogen hydrocarbon or acidic solvents to clean paint guns.
6. Pour paint into cup.

Figure 2:

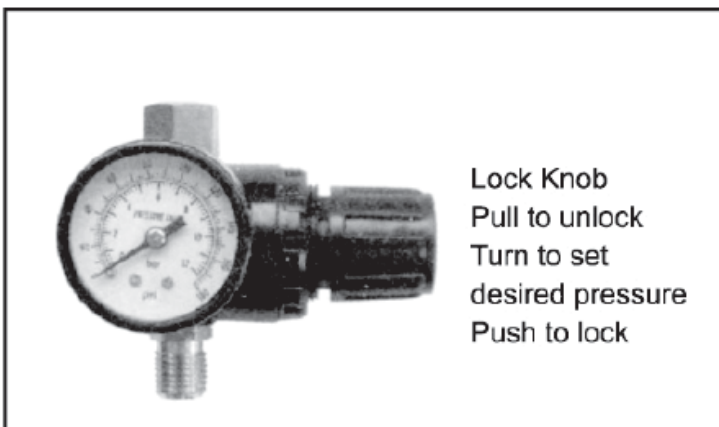

GUN HANDLING

For best results, please follow these basic guidelines:

1. Keep the spray gun perpendicular to the surface. Spraying in an arc will not give good results. (Fig. 3)
2. Keep gun moving from one side to the other while spraying. If you stop moving the gun while you are spraying, too much paint will build up and begin to run. Begin the horizontal movement of the gun before you begin spraying. Also, keep the gun at a constant distance 6-12 inches from the surface. (Fig. 4)

Figure 3 – INCORRECT

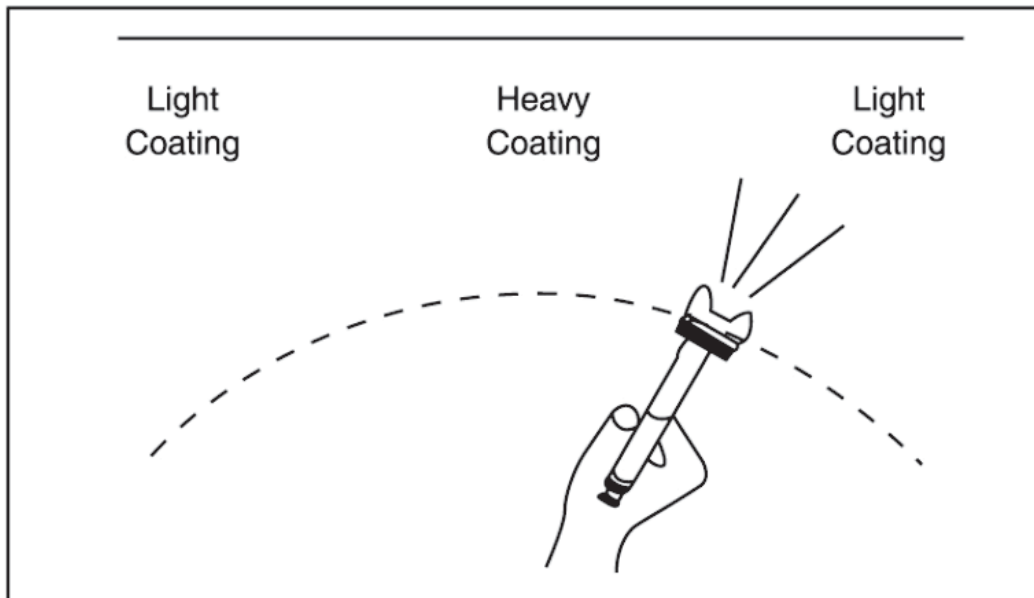
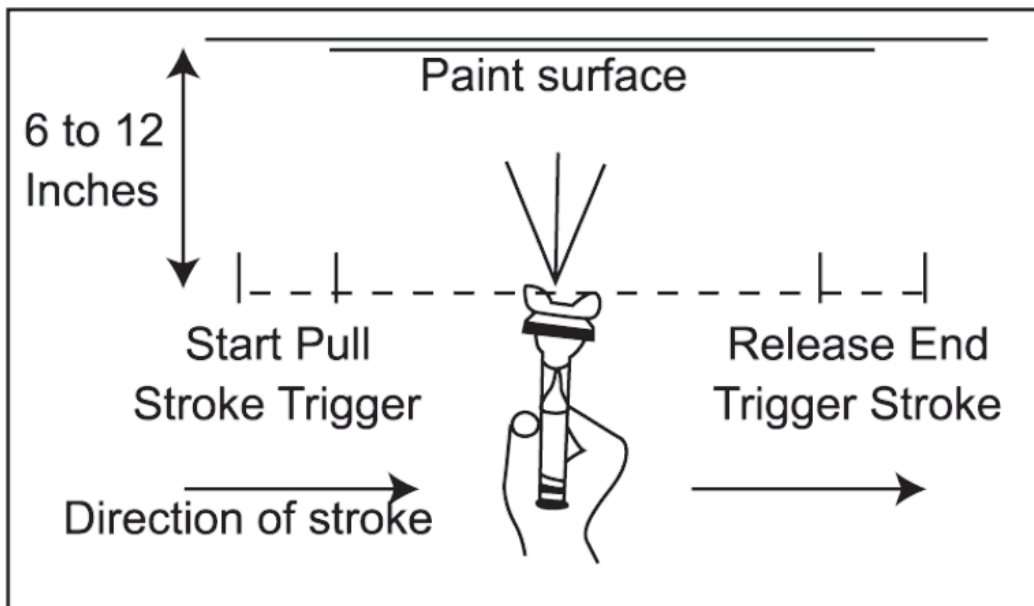

Figure 4 – CORRECT



ADJUSTMENT

1. Fine-tune the gun to your desired working settings of spray patterns, fluid output and degree of paint atomization using the three controls illustrated in Figure 5.

Figure 5

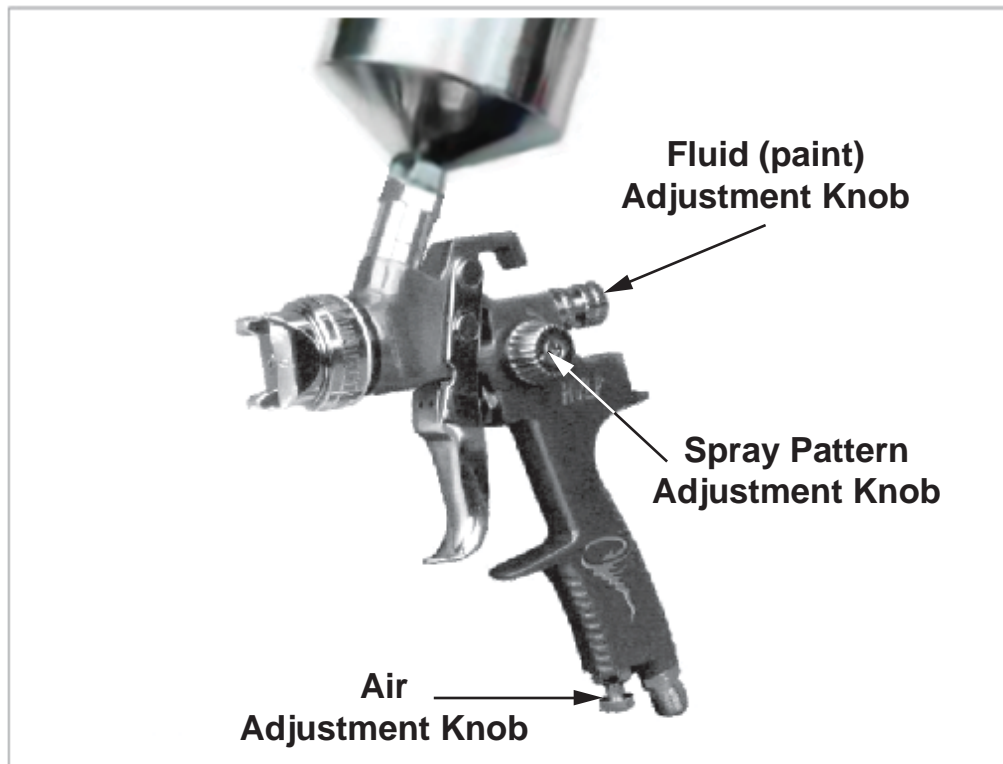

Maintenance

To clean the gun, pour any leftover paint back into its container. Using thinner, clean out the paint cup and cap. Spray some thinner through the gun to clean the spray head, needle and nozzle. Spray until thinner comes out clean. Clean all paint passages as any paint left in the gun and allowed to dry can clog the spray head. Wipe the exterior of the gun with the cleaning brush included and a soft cloth moistened with thinner. If you remove the needle, remove the nozzle as well to protect the seat. **NEVER DIG WITH A WIRE OR HARD OBJECT AS THIS CAN DAMAGE THE NEEDLE SEAT.** Remove all such paint before it has a chance to dry.



ATD-6901
1.4mm Gun
 (See drawing for parts)



ATD-6902
1.8mm Gun
 (See drawing for parts)



ATD-6903
1.0mm Gun
 (See drawing for parts)



ATD-7812
 Spray Gun Filter



PRT6900-TK
 Tool Cleaning Kit



ATD-6926
 Regulator

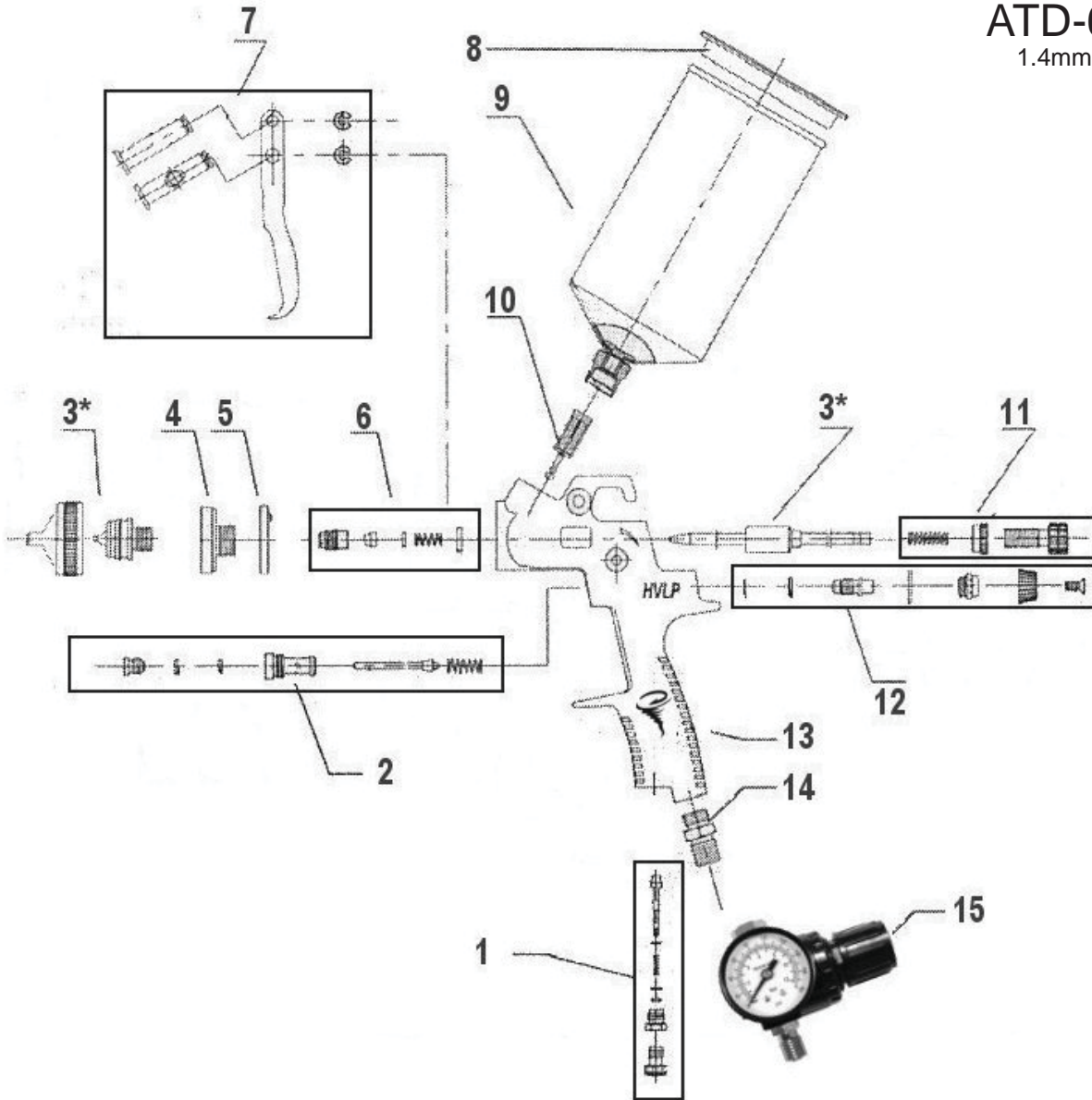

ITEM#	ORDERING PART#	PART DESCRIPTION
1	PRT6900-01	AIR ADJUST ASSY
2	PRT6900-02	AIR VALVE ASSEMBLY
3*	PRT6900-1.4	1.4mm TIP KIT (NEEDLE, FLUID NOZZLE, AIR CAP)
4	PRT6900-04	FLUID NOZZLE PLUG
5	PRT6900-05	FLUID NOZZLE WASHER
6	PRT6900-06	NEEDLE PACKING ASSEMBLY
7	PRT6900-07	TRIGGER ASSEMBLY
8	PRT6900-08	LID FOR CUP

ITEM#	ORDERING PART#	PART DESCRIPTION
9	PRT6900-09	CUP
10	PRT6900-10	FILTER (PACK OF 10)
11	PRT6900-11	FLUID ADJUST ASSEMBLY
12	PRT6900-12	PATTERN ADJUST ASSEMBLY
13	PRT6900-13	GUN BODY
14	PRT6900-14	AIR INLET FITTING
15	ATD-6926	REGULATOR
N/A	PRT6900-RK	REPAIR KIT (ALL SEALS AND SPRINGS)

* - Parts available as set only

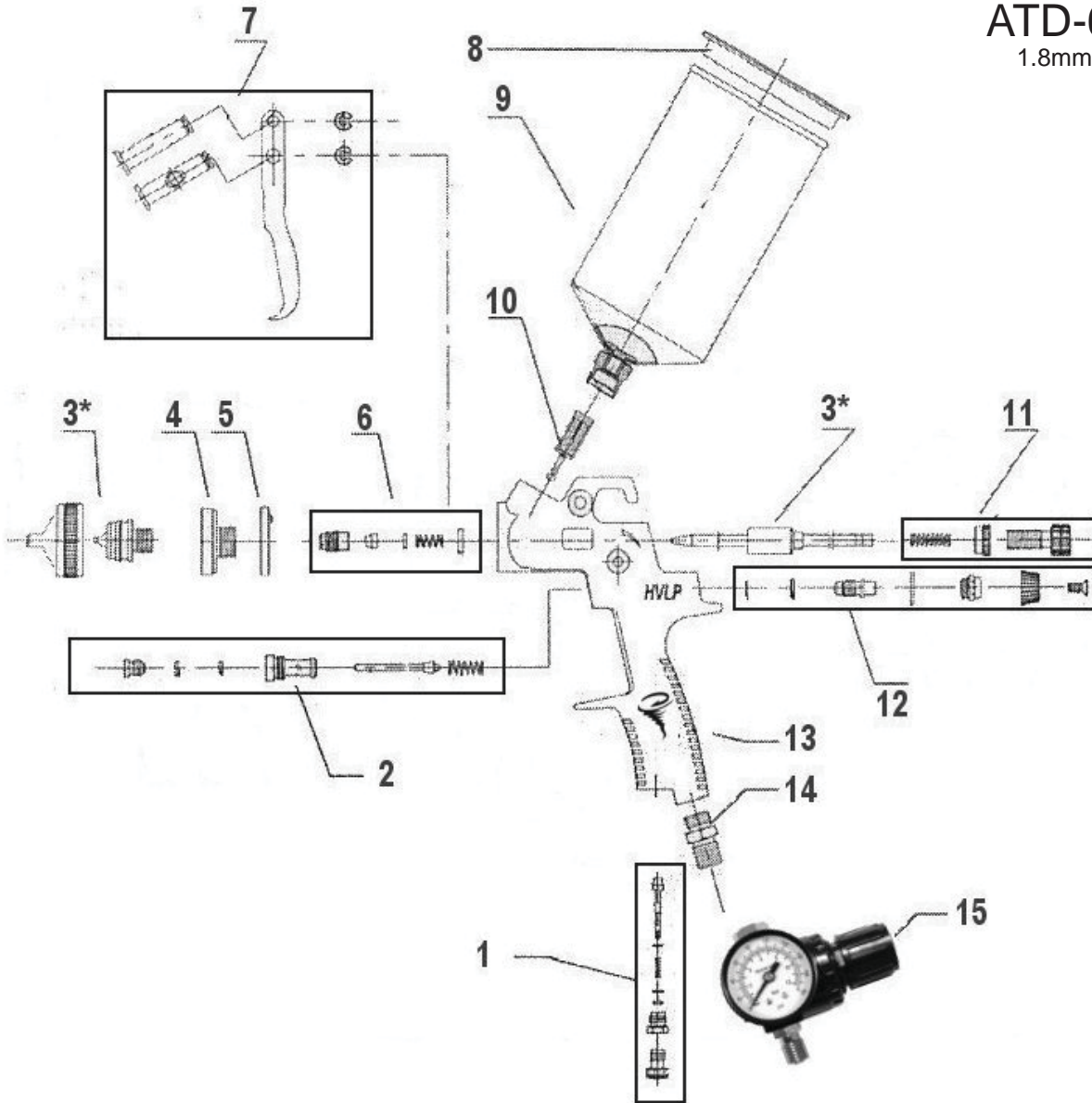

ITEM#	ORDERING PART#	PART DESCRIPTION
1	PRT6900-01	AIR ADJUST ASSY
2	PRT6900-02	AIR VALVE ASSEMBLY
3*	PRT6900-1.8	1.8mm TIP KIT (NEEDLE, FLUID NOZZLE, AIR CAP)
4	PRT6900-04	FLUID NOZZLE PLUG
5	PRT6900-05	FLUID NOZZLE WASHER
6	PRT6900-06	NEEDLE PACKING ASSEMBLY
7	PRT6900-07	TRIGGER ASSEMBLY
8	PRT6900-08	LID FOR CUP

ITEM#	ORDERING PART#	PART DESCRIPTION
9	PRT6900-09	CUP
10	PRT6900-10	FILTER (PACK OF 10)
11	PRT6900-11	FLUID ADJUST ASSEMBLY
12	PRT6900-12	PATTERN ADJUST ASSEMBLY
13	PRT6900-13	GUN BODY
14	PRT6900-14	AIR INLET FITTING
15	ATD-6926	REGULATOR
N/A	PRT6900-RK	REPAIR KIT (ALL SEALS AND SPRINGS)

* - Parts available as set only



ATD-6903
1.0mm Gun

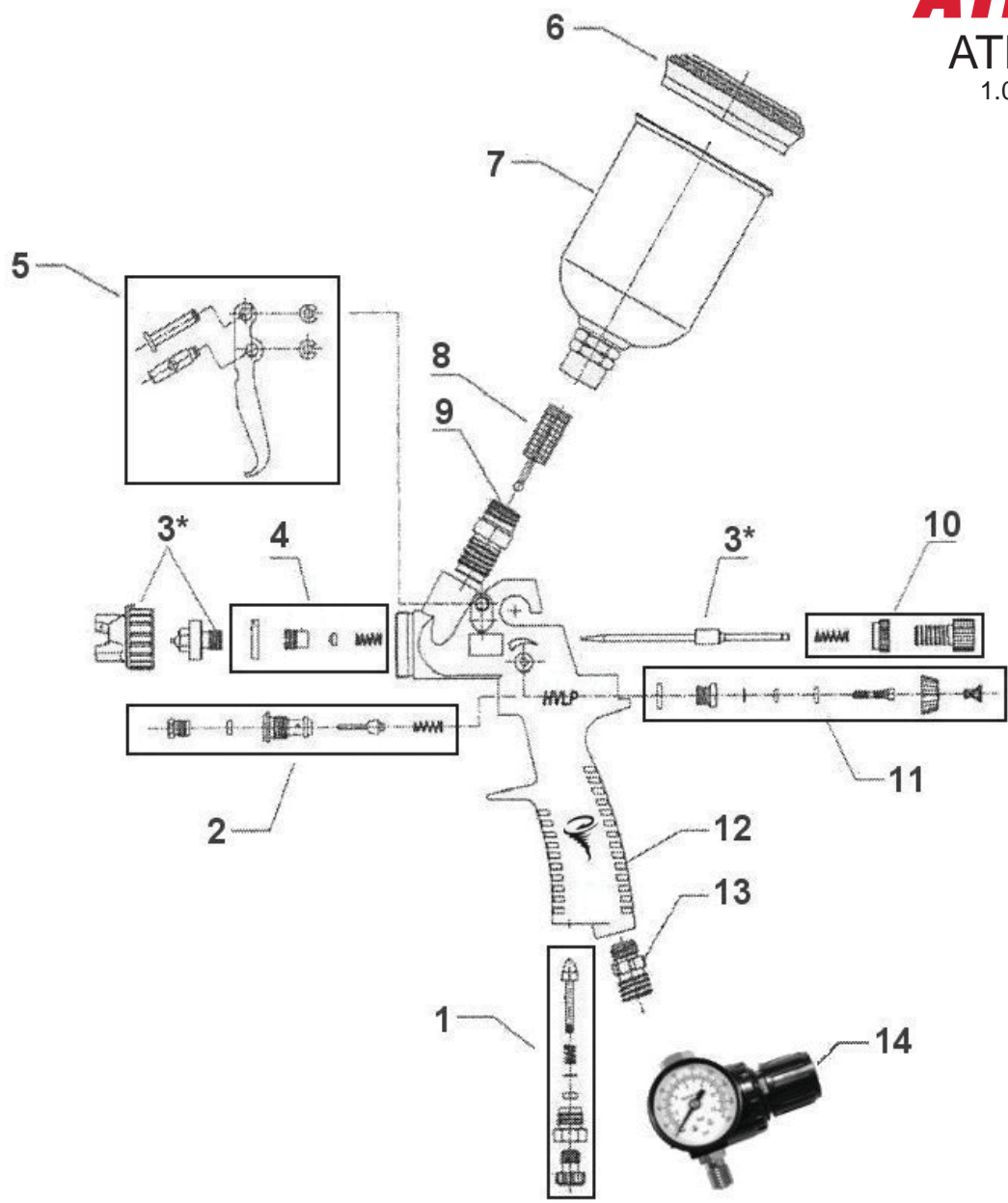

ITEM#	ORDERING PART#	PART DESCRIPTION
1	PRT6900-16	AIR ADJUST ASSY
2	PRT6900-17	AIR VALVE ASSEMBLY
3*	PRT6900-1.0	1.0mm TIP KIT (NEEDLE, FLUID NOZZLE, AIR CAP)
4	PRT6900-18	NEEDLE PACKING ASSEMBLY
5	PRT6900-19	TRIGGER ASSEMBLY
6	PRT6900-20	LID FOR CUP
7	PRT6900-21	CUP
8	PRT6900-10	FILTER (PACK OF 10)

ITEM#	ORDERING PART#	PART DESCRIPTION
9	PRT6900-22	FLUID INLET JOINT
10	PRT6900-23	FLUID ADJUST ASSY
11	PRT6900-24	PATTERN ADJUST ASSY
12	PRT6900-25	GUN BODY
13	PRT6900-26	AIR INLET FITTING
14	ATD6926	REGULATOR
N/A	PRT6900-RK1.0	REPAIR KIT (ALL SEALS AND SPRINGS)

* - Parts available as set only