

**ADCOM<sup>®</sup>  
PREAMP  
GFP-555II**

**THE FOLLOWING PRECAUTIONS AND SAFETY INSTRUCTIONS  
ARE REQUIREMENTS OF UL AND CSA SAFETY REGULATIONS**

**Warning: To reduce the risk of fire or electric shock, do not expose this unit to rain or moisture.**

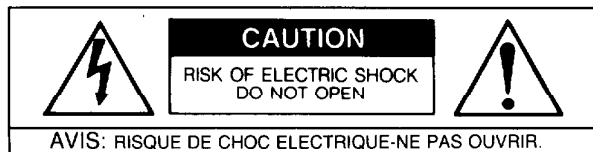

The graphic symbol of a lightning flash with an arrow point within a triangle signifies that there is dangerous voltage within the unit and it poses a hazard to anyone removing the cover to gain access to the interior of the unit. **Only qualified service personnel should make any such attempt.**



The graphic symbol of an exclamation point within an equilateral triangle warns a user of the device that it is necessary to refer to the instruction manual and its warnings for proper operation of the unit.



Do not place this unit on an unstable cart, stand, tripod, bracket, or table. The unit may fall, causing serious injury to a child or adult, and serious damage to the unit. Use only with a cart, stand, tripod, bracket, or table recommended by the manufacturer, or sold with the unit. Any mounting of the device should follow the manufacturer's instructions, and should use a mounting accessory recommended by the manufacturer.

Read all the safety and operating instructions before connecting or using this unit.

Retain this notice and the owner's manual for future reference.

All warnings on the unit and in its operating instructions should be adhered to.

All operating and use instructions should be followed.

Do not use this unit near water; for example, near a bathtub, washbowl, kitchen sink, laundry tub, in a wet basement, or near a swimming pool.

The unit should be installed so that its location or position does not interfere with its proper ventilation. For example, it should not be situated on a bed, sofa, rug, or similar surface that may block the ventilation openings; or placed in a built-in installation, such as bookcase or cabinet, that may impede the flow of air through its ventilation openings.

The unit should be situated away from heat sources such as radiators, heat registers, stoves, or other devices (including amplifiers) that produce heat.

The unit should be connected to a power-supply outlet only of the voltage and frequency marked on its rear panel.

The power-supply cord should be routed so that it is not likely to be walked on or pinched, especially near the plug, convenience receptacles, or where the cord exits from the unit.

Clean unit only as recommended in its instruction manual.

The power-supply cord of the unit should be unplugged from the wall outlet when it is to be unused for a long period of time.

Care should be taken so that objects do not fall, and liquids are not spilled, into the enclosure through any openings.

This unit should be serviced by qualified service personnel when:

- A. The power cord or the plug has been damaged; or
- B. Objects have fallen, or liquid has been spilled, into the unit; or
- C. The unit has been exposed to rain, or liquids of any kind; or
- D. The unit does not appear to operate normally, or exhibits a marked change in performance; or
- E. The device has been dropped, or the enclosure damaged.

**DO NOT ATTEMPT SERVICING OF THIS UNIT YOURSELF.  
REFER SERVICING TO QUALIFIED SERVICE PERSONNEL.**

**ATTENTION**

POUR PRÉVENIR LES CHOCS ÉLECTRIQUES NE PAS UTILISER CETTE FICHE POLARISÉE AVEC UN PROLONGATEUR, UNE PRISE DE COURANT OU UNE AUTRE SORTIE DE COURANT, SAUF SI LES LAMES PEUVENT ÊTRE INSÉRÉES À FOND SANS EN LAISSER AUCUNE PARTIE À DÉCOUVERT.

**CAUTION**

TO PREVENT ELECTRIC SHOCK DO NOT USE THIS POLARIZED PLUG WITH AN EXTENSION CORD, RECEPTACLE OR OTHER OUTLET UNLESS THE BLADES CAN BE FULLY INSERTED TO PREVENT BLADE EXPOSURE.

**CAUTION  
POWER LINES**

Any outdoor antenna must be located away from all power lines.

**OUTDOOR ANTENNA GROUNDING**

If an outside antenna is connected to your tuner or tuner-preamplifier, be sure the antenna system is grounded so as to provide some protection against voltage surges and built-up static charges. Section 810 of the National Electrical Code, ANSI/NFPA No. 70-1984, provides information with respect to proper grounding of the mast and supporting structure, grounding of the lead-in wire to an antenna discharge unit, size of grounding conductors, location of antenna discharge unit, connection to grounding electrodes, and requirements for the grounding electrode.

- a. Use No.10 AWG (5.3 mm<sup>2</sup>) copper, No.8 AWG (8.4 mm<sup>2</sup>) aluminum, No.17 AWG (1.0 mm<sup>2</sup>) copper-clad steel or bronze wire, or larger, as a ground wire.
- b. Secure antenna lead-in and ground wires to house with stand-off insulators spaced from 4-6 feet (1.22-1.83 m) apart.
- c. Mount antenna discharge unit as close as possible to where lead-in enters house.
- d. Use jumper wire not smaller than No.6 AWG (13.3 mm<sup>2</sup>) copper, or the equivalent, when a separate antenna-grounding electrode is used. See NEC Section 810-21 (j).

EXAMPLE OF ANTENNA GROUNDING AS PER NATIONAL ELECTRICAL CODE INSTRUCTIONS CONTAINED IN ARTICLE 810 - RADIO AND TELEVISION EQUIPMENT.

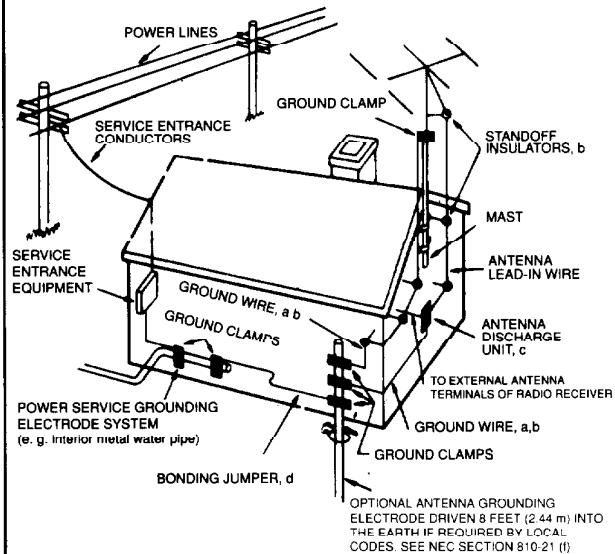

**NOTE TO CATV SYSTEM INSTALLER**

This reminder is provided to call the CATV system installer's attention to Article 820-22 of the National Electrical Code that provides guidelines for proper grounding and, in particular, specifies that the cable ground shall be connected to the grounding system of the building, as close to the point of cable entry as practical.

## FEATURES

Although the front panels of the GFP-555 and GFP-555II are very similar in appearance, the GFP-555II has been completely redesigned internally and electronically. All desirable features and benefits of the GFP-555 have been retained in the GFP-555II; in addition, the GFP-555II boasts the most advanced, state-of-the-art devices and circuit topologies to insure performance superior to that of any preamplifier at or near its price level. Among the benefits provided by the GFP-555II are:

- Low-impedance power supply for best regulation and optimal circuit performance. This type of design insures that music dynamics are delivered through the preamplifier totally uncompressed.
- Enlarged power-supply traces on a double, copper-plated printed circuit board for minimal losses and improved voltage stability. This technique insures constant voltage to all the circuitry, regardless of volume or dynamic demands of the music.
- All capacitors are state-of-the-art electrolytics and film capacitors with very low ESR and unsurpassed sonic purity. This design feature provides an audible benefit, the lowest possible distortion of music signals.
- New, larger, all-mu-metal-shielded power transformer for better regulation. This type of transformer design eliminates stray hum fields for lowest noise (especially in phono) and provides undiminished voltage to circuits for best performance under any demands for level.
- New, precision, programmable regulators for stabilized, constant DC voltages, regardless of load. This type of regulator insures stable operation of all circuits regardless of the dynamic demands of the music being played.
- Signal-path amplifier stages use premium-grade ICs selected for their linear operation and sonic quality. These linear amplifiers insure extremely low noise, low distortion and low DC offset for best performance with either set of preamp outputs.
- All stages are operated in pure Class-A mode to insure lowest distortion regardless of the signal level or setting of the volume control.
- Entire signal path is direct-coupled from input to output when using BYPASS OUTPUT. Direct coupling minimizes the number of components signal must go through insuring no degradation of the music signal.
- Two sets of outputs: BYPASS OUTPUT is direct-coupled and placed before tone controls, filters, etc. They provide a signal in the most straightforward, simplest path. MAIN OUTPUT is capacitor-coupled using precision, high-grade film capacitors for virtually zero signal degradation, but providing switchable tone controls, filter, loudness contour, and mono mode. MAIN OUTPUT has provision to insert a simple jumper to remove the capacitors from the output circuit when a direct-coupled signal is desired.
- Low-output-impedance (100 ohms) from both sets of outputs to reduce interaction of connecting cables and other equipment and preserve music dynamic contrasts. This low-impedance output design guarantees that full dynamic range of the signal will be preserved regardless of cable characteristics or amplifier load.
- Extremely-low-noise phono preamplifier with virtually zero RIAA error, optimized for high-output moving-coil and moving-magnet cartridges plus direct-coupled signal output for maximum bass impact and dynamic response. These features will provide the flattest, lowest noise, lowest distortion response from a phono cartridge and virtually perfect reproduction from any record.
- Low-impedance, RIAA-equalization network. This unique network insures the lowest achievable noise level in a phono preamp.
- Low-impedance tape outputs to perfectly interface with any type of tape recorder. This technique allows the preamp to mate with any type recorder, including DAT, and insures the best recording characteristics independently of the cable used and the load impedance of the tape recorder inputs.
- Buffered tape outputs to preserve input-source-signal integrity and preclude "loading" of the signal-source component and distortion. Buffering prevents the degradation of the source signal by most tape recorders when these are connected to the tape outputs. These buffers insure that the integrity of the internal signal path will not be affected by the tape recorder used.
- Front-panel-switchable processor loop. Shortens the signal path by switching the processor in and out of the circuit directly on the main circuit board. Allows the processor to be removed totally from the circuit when not needed.
- All high-grade construction parts including 1%, Roederstein metal-film resistors and all metallized-film, precision capacitors throughout. These components help achieve lower noise levels and lower signal degradation than preamps selling for many times the price of the GFP-555II.
- Improved headphone amplifier, optimized for use with headphone impedances of 100 to 2,000 ohms.

## **IMPORTANT NOTICE**

### **ADCOM PROTECTION PLAN (U.S.A. ONLY)**

ADCOM offers the enclosed valuable Limited Warranty. Please read the details on the Warranty Card carefully to understand the extent of the protection offered by the Warranty, its reasonable limitations, and what you should do in order to obtain its benefits.

Be sure to verify that the serial number printed on the back panel matches the serial number on the outer carton. If either number is altered or missing, or if the Warranty Card is not included in the carton, you should notify us immediately in order to insure that you have received a genuine ADCOM product which has not been opened, mishandled or tampered with in any way.

## **INTRODUCTION**

Please read thoroughly these operating instructions for the GFP-555II before connecting or attempting to operate this unit. For your own benefit, follow all the instructions in this manual and save it for future reference.

The ADCOM GFP-555II is a result of a thorough examination and reevaluation of all factors affecting the sonic performance of preamplifiers. A great deal of care was taken to insure that the audio performance of the GFP-555II could be maintained for years to come by the selection of top-quality components and circuit topologies. The result is a preamplifier which is as musical-sounding as, and which preserves the dynamic contrasts of, an original performance.

The installation and operation of the GFP-555II are described in the following pages. We sincerely hope you will value and enjoy the considerable attention we have given its design and construction. This manual has been written to help you understand the correct operation of the GFP-555II. Please read it carefully to fully comprehend all its features and functions and thereby derive the maximum performance from its use in your system.

## **UNPACKING**

Before each GFP-555II left the factory, it was carefully inspected for physical imperfections and electrical performance as a routine part of ADCOM's systematic Quality Control. This, along with full operational and mechanical testing, should insure a product flawless in both appearance and performance. After you have unpacked the GFP-555II, inspect it for physical damage. Save the shipping carton and all packing materials as they are intended to reduce to a minimum the possibility of transportation damage, should the product ever need to be shipped again. In the unlikely event damage has occurred, notify your dealer immediately and request the name of the carrier so that a written claim to cover shipping damage can be initiated.

**THE RIGHT TO A CLAIM AGAINST A PUBLIC CARRIER CAN BE FORFEITED IF THE CARRIER IS NOT NOTIFIED PROMPTLY IN WRITING AND IF THE SHIPPING CARTON AND PACKING MATERIALS ARE NOT AVAILABLE FOR INSPECTION BY THE CARRIER. SAVE ALL PACKING MATERIALS UNTIL THE CLAIM HAS BEEN SETTLED.**

## **INSTALLING THE GFP-555II**

Although the GFP-555II does not generate much heat, you will help insure its long-term, trouble-free operation if you keep it away from external sources of heat, such as radiators or hot-air ducts, and provide reasonable ventilation. The GFP-555II should never be placed with other heat-producing components in a cabinet or enclosure lacking free air flow. If placed near or above any heat-producing component, such as a power amplifier, please allow a minimum of three inches between the components.

For use in professional installations, the GFP-555II may be mounted in a standard 19-inch rack using the optional RM-3 rack-mount adaptors available through ADCOM dealers.

## CONNECTING THE GFP-555II

The performance of the GFP-555II will depend on the quality of the interconnection of both the preamplifier and its associated equipment. All the input- and output-signal connections should be made only with high-quality, low-loss audio cables such as the one supplied with the GFP-555II. LEFT and RIGHT inputs and outputs are clearly labelled on the rear panel.

### NOTE

**WHENEVER CONNECTIONS TO OR FROM THE GFP-555II ARE BEING MADE, BE CERTAIN ALL ASSOCIATED COMPONENTS ARE TURNED OFF.**

### GND ①

Ground connection to chassis is provided primarily to connect phonograph (turntable) ground terminals. Most turntables are supplied with a separate ground wire to help eliminate hum. Connect the separate ground wire, if supplied with your turntable, to the GND ① terminal. The GND ① terminal can also be used to connect the chassis of the GFP-555II directly to the center screw of your AC wall outlet or other good "earth" connection such as a water pipe or radiator. This earth connection may be useful in areas of high RF interference, and may help to minimize noise particularly when playing low-output-level phonograph cartridges.

### NOTE

Although the GND ① connection is probably the best place at which to connect your system to a good earth ground, it should be pointed out that only **one** connection to an earth ground is to be made in any system. Otherwise what is commonly known as a "ground-loop" will be caused and hum and noise may increase sufficiently to become a nuisance. In any system, only **one** ground connection can be made to earth. If one of your components is supplied with a three-prong AC connector which is plugged into the AC wall outlet, earth connection will be made through this plug and additional ground connections are not recommended. Similarly, if the system's units are mounted in a rack and ground connection between the chassis is made through the rack mounting, special techniques must be undertaken to minimize ground-loops and subsequent noise. A detailed discussion of ground-loops with methods for their elimination is beyond the scope of this manual.

### PHONO HI MC/MM ②

These two standard RCA jacks will accept all common RCA plugs, one for each channel, left and right, usually supplied at the ends of the turntable's cables. LEFT and RIGHT PHONO ② inputs are clearly labelled. Determine the exact color coding or markings on your turntable's cable for left and right channels in order to insure the correct connections.

The PHONO ② circuitry is designed to accept the signal from any high-output moving-coil, moving-magnet, induced-magnet, moving-iron or variable-reluctance cartridge, the output from which is rated at 2.2mV/cm or higher. The PHONO ② input electrical impedance characteristics are the standard 47,000 ohms with 100pF shunt capacitance. ADCOM high-output moving-coil cartridges, for example, are ideally suited for use with this phono preamplifier. Low-output moving-coil cartridges which normally require a pre-preamplifier (sometimes referred to as a "head-amp"), or step-up transformer, must have these auxiliary devices connected **before** the PHONO ② input. A pre-preamplifier, or step-up transformer, provides the additional gain required by very-low-output moving-coil cartridges to operate with a standard phono preamplifier. A pre-preamplifier, or step-up transformer, is not necessary, and must **not** be used, with high-output moving-coil cartridges or moving-magnet, induced-magnet, etc. cartridges. If you are uncertain as to which type of cartridge you will be using, please consult the instruction manual or specification sheet which is included with your cartridge, or contact the dealer from whom you purchased the cartridge, or the cartridge manufacturer.

A provision has been made on the printed-circuit board of the GFP-555II (in the form of two unused "eyelets") to allow easy modification, by your ADCOM dealer, of the impedance characteristics of the PHONO ② input if the cartridge you plan to use requires a load different from the standard 47,000 ohms/100pF. Please note that the change in load impedance which can be made to the PHONO ② input of the GFP-555II does **not** change the gain characteristics of the phono preamp, and, therefore, does not permit the use of a low-output moving-coil cartridge with the GFP-555II. Only in unusual cases will this minor modification have to be undertaken, since most modern phono cartridges are designed to work into the standard load provided by the GFP-555II.

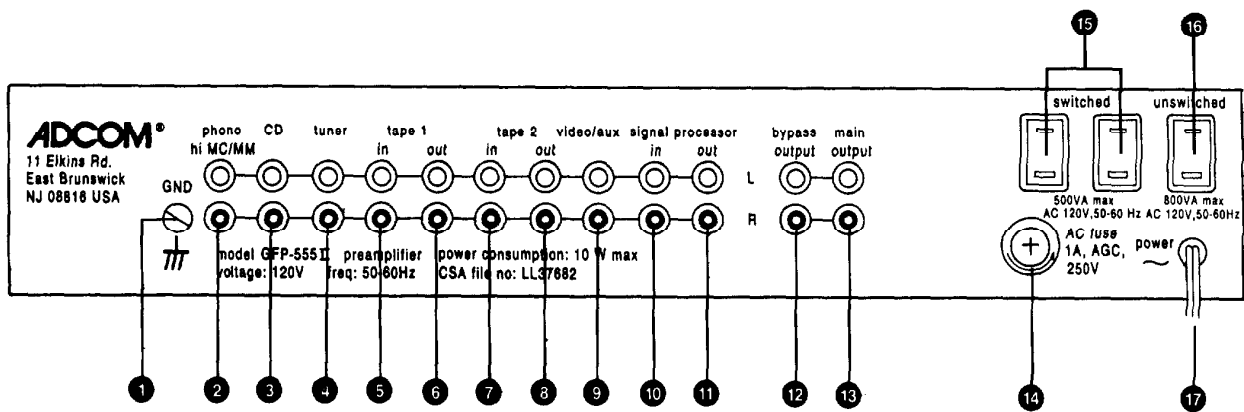

GFP-555II Rear Panel Diagram

### CD ③

This set of input jacks is for use with a Compact Disc (CD) player or other similar high-level signal source, such as a tape player, the audio signal from a video-disc player, or video-cassette recorder (VCR). The load impedance of this input is approximately 22,000 ohms.

### TUNER ④

Although this pair of inputs is provided for your tuner, they may be used with any other high-level source such as a tape player, an additional Compact Disc (CD) player or other similar high-level signal source. The load impedance of this input is identical to that of the CD ③ input.

### TAPE 1 IN ⑤ / TAPE 2 IN ⑦

These two sets of tape inputs are identical in sensitivity and electrical characteristics to the CD ③ inputs and the comments made about the CD ③ inputs apply. These may be used not only for cassette or other audio tape recorders (such as a DAT), but also with any high-level signal source, such as a VCR's audio outputs, etc.

These two sets of tape inputs are also part of a "cross-dubbing" tape circuit. Refer to TAPE 1 OUT ⑥ / TAPE 2 OUT ⑧ below for interconnection of the tape-dubbing facility.

If you desire simple playback of pre-recorded tapes, plug the left and right outputs of your tape machine labeled "tape out" or "line out" into either set of TAPE 1 IN ⑤ or TAPE 2 IN ⑦ jacks using a set of good-quality, low-loss audio cables.

### TAPE 1 OUT ⑥ / TAPE 2 OUT ⑧

The outputs from these jacks are selected by the RECORDING ⑲ selector on the front panel. Whichever input is selected via the RECORDING ⑲ knob will appear at the TAPE 1 OUT ⑥ and TAPE 2 OUT ⑧ jacks. It should be pointed out that when the RECORDING ⑲ selector is placed in the TAPE 1 position, the TAPE 1 IN ⑤ inputs will appear **only** at the TAPE 2 OUT ⑧ jacks. Similarly, if TAPE 2 IN ⑦ is selected by the RECORDING ⑲ knob, the TAPE 2 IN ⑦ inputs will appear **only** at the TAPE 1 OUT ⑥ jacks.

This type of system permits "cross-dubbing" from one cassette deck to another or from one audio recorder to another without having to disconnect, or change connections from, either cassette or tape recorder.

To hook-up the TAPE 1 OUT ⑥ to your cassette or tape recorder, connect the right and left jacks on the cassette or tape recorder labeled "line in" or "record in" to the corresponding LEFT and RIGHT TAPE 1 OUT ⑥ jacks on the rear panel of the GFP-555II. To connect the TAPE 2 OUT ⑧ jacks to another recorder proceed in the same manner outlined above. It is very important that you use only high quality, low-loss interconnecting cables, in order not to degrade the quality of the recording.

## NOTE

Both the TAPE 1 OUT ⑥ and TAPE 2 OUT ⑧ circuits are individually and actively "buffered" in order to insure that the signal within the circuitry of the GFP-555II will not be compromised regardless of whether the tape recorders are in use or not. Therefore, you can listen to the same source which you are recording, or any other source, without fear of degrading the signal either in the recording or the listening mode. In addition, the buffered outputs will prevent the normal degradation that tape recorder inputs cause an audio signal in a preamplifier when the tape recorder circuits are turned off and not in operation.

## VIDEO/AUX 9

This set of input jacks is for use with any high-level signal source and is identical in sensitivity and electrical characteristics to the CD 3 inputs. All the comments and recommendations made about the CD 3 inputs apply.

## SIGNAL PROCESSOR IN 10 / SIGNAL PROCESSOR OUT 11

This set of inputs and outputs is provided for use with any "signal processor" such as an equalizer, time delay, surround sound decoder, etc. The SIGNAL PROCESSOR IN 10 / SIGNAL PROCESSOR OUT 11 jacks are selected and controlled by the front-panel button labelled PROCESSOR IN 28. Pushing in the PROCESSOR IN 28 button will connect whatever processor is plugged into the SIGNAL PROCESSOR IN 10 / SIGNAL PROCESSOR OUT 11 jacks to the circuitry of the GFP-555II. Pushing in and releasing the PROCESSOR IN 28 button will disconnect the SIGNAL PROCESSOR IN 10 / SIGNAL PROCESSOR OUT 11 jacks from the circuitry of the preamplifier. It is important to note that when the PROCESSOR IN 28 button is released, both of the jacks (SIGNAL PROCESSOR IN 10 and SIGNAL PROCESSOR OUT 11) are electrically removed from the circuitry of the preamplifier (and, so, consequently whatever processor is plugged into these jacks) to prevent any possible degradation of the signal selected through the RECORDING 29 and LISTENING 30 switches.

To connect the processor, equalizer or surround sound decoder, etc., to the GFP-555II always use high-quality, low-loss audio cables. Plug the jacks on the signal processor labelled "input", "in", "line in" or "source" into the SIGNAL PROCESSOR OUT 11 jack on the rear panel of the GFP-555II, observing the left and right labelling on both sets of jacks. Plug the jacks on the signal processor marked "output", "out" or "line out" to the GFP-555II jacks labelled SIGNAL PROCESSOR IN 10. Once these connections have been effected, simply pushing in the PROCESSOR IN 28 button on the front panel of the GFP-555II will bring the processor into the circuit.

### NOTE

1. Please be advised that if no processor is plugged into the SIGNAL PROCESSOR IN 10 and SIGNAL PROCESSOR OUT 11 jacks, and the PROCESSOR IN 28 button is pushed in, all the inputs of the GFP-555II will be **disconnected** and no output signal will be present at either the BYPASS OUTPUT 12 or the MAIN OUTPUT 13 and, consequently, no sound will be heard through the system. Whenever a signal processor is not being used, the PROCESSOR IN 28 button should always be in the **out** position.
2. However, it is possible, when no processor is connected to the SIGNAL PROCESSOR IN 10 and SIGNAL PROCESSOR OUT 11 jacks, to use the PROCESSOR IN 28 button as a mute function. By pressing in the PROCESSOR IN 28 button, the signal will be interrupted until the PROCESSOR IN 28 button is, once again, pushed in and **released**.
3. Normally, the GFP-555II does not invert polarity; that is, if a positive-going signal is present at any of its inputs, it will appear as a positive-going signal at the outputs. However, if a signal processor is connected to the SIGNAL PROCESSOR IN 10 and SIGNAL PROCESSOR OUT 11 jacks, and its circuitry inverts polarity, the signals present at the BYPASS OUTPUT 12 and MAIN OUTPUT 13 will also be inverted in polarity (check the Instruction Manual of your signal processor to determine if it does or does not invert polarity). See also the NOTE under TONE IN 24 below.
4. Usually, there should be no appreciable level difference whenever a signal processor is connected into or out of the circuitry of the GFP-555II (through the use of the PROCESSOR IN 28 button), so long as the processor was designed with an absolute gain of 1 and adequate input and output impedances to fulfill this function. If a level difference can be detected when switching a processor in and out of the circuit, and this is disturbing to you, please contact the manufacturer of the processor you are using to see if a correction of this level difference can be effected.
5. It is also possible to employ the SIGNAL PROCESSOR IN 10 jacks as an additional set of inputs, since these jacks are located, in the circuitry, before the volume 31 and BALANCE 21 controls. If you wish to use the SIGNAL PROCESSOR IN 10 jacks as an additional input, simply plug the signal source into the SIGNAL PROCESSOR IN 10 jacks as you would any of the other inputs (CD 3, TUNER 4, etc.) and select that source by pushing in the PROCESSOR IN 28 button. Whatever other selection of sources has been made through the LISTENING 30 selector will be disconnected and the source plugged into the SIGNAL PROCESSOR IN 10 jacks will then be fed through the circuits of the GFP-555II and out of the BYPASS OUTPUT 12 and MAIN OUTPUT 13.

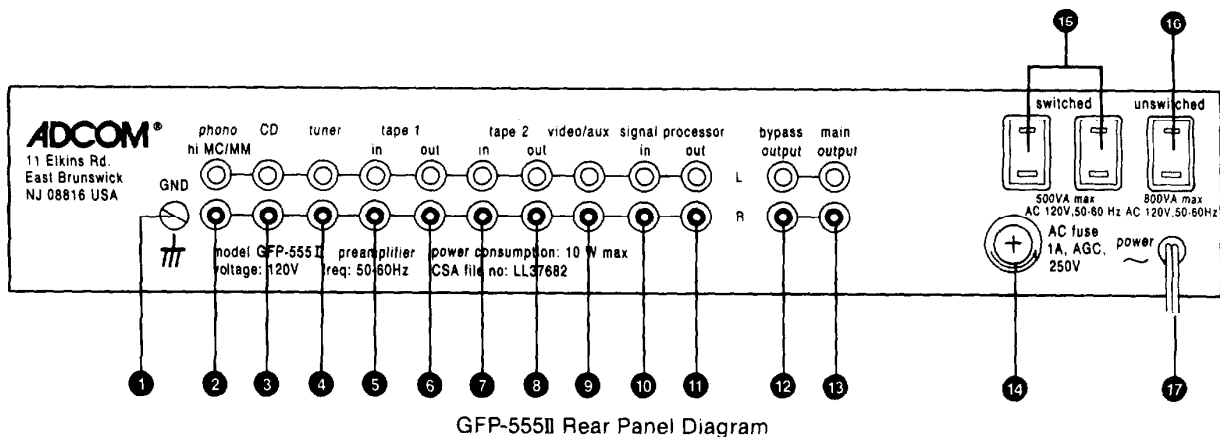

GFP-555II Rear Panel Diagram

Whatever processor is connected to the SIGNAL PROCESSOR IN **10** and SIGNAL PROCESSOR OUT **11** jacks will **not** be operative at the TAPE 1 OUT **6** and TAPE 2 OUT **8** jacks. If you wish to insert an equalizer into the tape recording circuits, this must be done through the specific TAPE 1 IN **5** and TAPE 1 OUT **6** jacks, or the TAPE 2 IN **7** and TAPE 2 OUT **8** jacks along with the particular tape recorder. In such an instance, this processor will not operate on any other source selected through the LISTENING **30** selector but will only operate on the tape loop to which it has been connected. Similarly, because of the design of the circuitry in the GFP-555II, and when the SIGNAL PROCESSOR IN **10** jacks are used as an additional high-level input, this individual signal will **not** appear at the TAPE 1 OUT **6** or the TAPE 2 OUT **8** jacks, nor can it be selected through the RECORDING **29** selector. Therefore, tape recordings **cannot** be made of the signal source plugged into the SIGNAL PROCESSOR IN **10** jacks. To return to usual operation of the preamplifier, push and **release** the PROCESSOR IN **20** button and the operation of all the switches and selectors will return to normal and the source plugged into the SIGNAL PROCESSOR IN **10** jacks will be disconnected from the circuitry of the GFP-555II.

### BYPASS OUTPUT **12**

This set of jacks was designed to provide as simple a signal path as possible. The tone controls and filter, switches, etc. are **not** in the signal path when these outputs are used. Essentially, when using these outputs, the signal comes into the GFP-555II, goes through the LISTENING **30** switch, through the volume **31** and BALANCE **27** controls into a single amplification stage to buffer the source, and lower its impedance to 100 ohms, and directly out of the BYPASS OUTPUT **12** jacks.

The BYPASS OUTPUT **12** is direct-coupled with no capacitors and was designed to provide an output voltage ideally matched for operation with the ADCOM brand of amplifiers. It can be used, however, to drive almost any power amplifier presently available with input sensitivities ranging from below 500mV (0.5V) to well above 2.0V.

To connect this output to your power amplifier, simply interconnect the LEFT and RIGHT BYPASS OUTPUT **12** jacks to the corresponding left and right input jacks on the amplifier. To preserve the extremely high quality of the circuitry in the GFP-555II, it is recommended that you use either the cable supplied with the preamplifier or as high a quality cable as possible to make this interconnection.

It should be pointed out that, since the BYPASS OUTPUT **12** is direct-coupled, it is an extremely broadband circuit which responds down to DC (direct current). Therefore, it requires that your power amplifier (if it is not an ADCOM-brand amplifier) be able to handle this extremely broadband signal.

### NOTE

Both the BYPASS OUTPUT **12** and the MAIN OUTPUT **13** may be used simultaneously should you wish to bi-amp your speakers, or drive more than one amplifier. When using both of these outputs simultaneously, please refer to the NOTE under TONE IN **24** below.

### MAIN OUTPUT **13**

The MAIN OUTPUT **13** is capacitively coupled using extremely high-grade metallized polyester capacitors. It is ideal for use with power amplifiers that require a bandwidth-limited signal which does not extend to DC. Although this capacitively-coupled output does restrict somewhat the extremely low frequencies, around 1Hz or 2Hz, it does not, in any way, degrade the quality of the signal from the preamplifier. Great care was taken in the selection of the capacitors to preclude any sonic deterioration.

It is possible, for special applications, to bypass these capacitors by inserting two jumpers into eyelets provided on the PC board (J126 and J127), which can be easily done by your ADCOM dealer's Service Department. When these capacitors are jumped out, the MAIN OUTPUT **13** jacks are identical in operation to the BYPASS OUTPUT **12** jacks, so long as the TONE IN **24** and LOW FILTER **26** switches are in the **out** position. Please note that when the tone control circuits are activated by pushing in the TONE IN **24** button, the output from the MAIN OUTPUT **13** jacks will be inverted in polarity (see NOTE under TONE IN **24**).



The MAIN OUTPUT 13 jacks permit the use of all the optional controls and circuits, which are normally inoperative, so long as the individual switches, such as the TONE IN 24 and LOW FILTER 26, are pushed into the In position.

### NOTE

Although the GFP-555II was designed primarily for use with stereo power amplifiers, it can operate just as well with two mono power amplifiers. When two mono amplifiers are used for stereophonic reproduction, it is strongly suggested that they be a matched-pair with respect to brand, model, input sensitivity and power output.

### AC FUSE 14

The AC line fuse which protects the circuits of the GFP-555II is a Bussman 1-ampere, AGC/250V-type (Littelfuse 3AG312001/250V is a direct equivalent). This fuse should be replaced only with a fuse of the same current value, type and rating. Replacements with fuses of higher value and/or different rating and/or type will not protect the GFP-555II circuits, will void the Warranty, and **may cause a fire hazard.**

### NOTE

**Before checking or replacing a blown fuse, make certain you UNPLUG THE POWER 17 CORD FROM THE AC WALL OUTLET TO PREVENT POSSIBLE ELECTRICAL SHOCK.**

### SWITCHED 15 OUTLETS

The SWITCHED 15 outlets are controlled by the power switch 18 on the front panel of the GFP-555II. You may plug the AC line cord of your power amplifier, or any other accessory, which you want to turn on and off with the power switch 18 of the GFP-555II into these outlets. The current-carrying capacity of the switch 18 is sufficient to handle the inrush current of power amplifiers up to the 200-watt-per-channel class. It is not recommended that very-large-power amplifiers, above the 200-watt class, be plugged into these outlets (see NOTE below following UNSWITCHED 16 outlet).

### UNSWITCHED 16 OUTLET

The UNSWITCHED 16 outlet can supply the AC power requirements of any accessory source used with the GFP-555II, such as a CD player or analog turntable. The AC line cord of the accessory may be plugged into this outlet. The UNSWITCHED 16 outlet is not controlled by the power switch 18 on the front panel of the GFP-555II, and 120VAC will always be available at this outlet so long as the GFP-555II is plugged into an energized wall outlet, regardless of the position of the main power switch 18. The total power drawn through the UNSWITCHED 16 outlet must never exceed 800 watts.

### NOTE

Most electronic or electrical devices state the maximum power drawn by the device on a plate, or label, on the rear panel of the unit, near the AC line cord which supplies power to the unit. It is a good idea to check these requirements before plugging an amplifier into either the UNSWITCHED 16 outlet or the SWITCHED 15 outlets. Most large-power amplifiers should be plugged directly into an AC wall outlet or an ADCOM ACE-515 AC Enhancer for overall maximum performance and best power delivery.

### POWER 17

This cord provides AC power to operate the GFP-555II's circuits and energize the SWITCHED 15 and UNSWITCHED 16 accessory outlets. The AC line cord should be plugged into any standard wall outlet providing 120VAC, 50-60Hz.

## NOTE

The GFP-555II's power cord is supplied with a "polarized" AC plug as required by UL/CSA standards and local electrical codes. To minimize the risk of electrical shock, and to insure minimal hum from the system, do not defeat the polarity-insuring feature of the plug (one wide blade and one narrow blade). To prevent electrical shock, do not use this polarized plug with an extension cord or receptacle, or other outlet, unless the blades can be fully inserted to prevent blade exposure.

## CONTROLLING THE GFP-555II

Please refer to the diagram of the front panel of the GFP-555II to identify all the controls and their functions.

### AC ON/OFF SWITCH 18 19

The "rocker" AC on/off switch 18 controls power to the circuits of the GFP-555II and to the SWITCHED 15 outlets on the rear panel of the GFP-555II. Whenever the GFP-555II is energized, the red LED 19 will glow. Push the top of the rocker switch to energize the GFP-555II. Push the bottom of the rocker switch to turn the unit off.

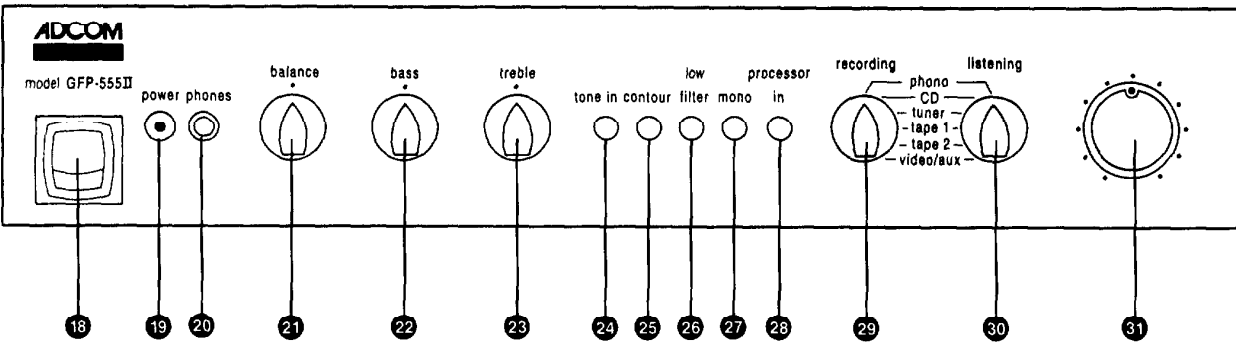

GFP-555II Front Panel Diagram

### PHONES 20

The headphone jack is a standard, 1/4-inch, 3-contact type which will operate with any conventional set of stereo headphones. If you have a set of light-weight stereo headphones, which are generally supplied with a mini-phoneplug, you may use a stereo phoneplug-to-miniplug adaptor.

The PHONES 20 jack is powered by its own high-quality stereo amplifier, the level from which is governed by the setting of the volume 31 control. The amplifier driving the PHONES 20 jack has been optimized to operate with headphones having an impedance of 100 ohms up to 2,000 ohms. Although the PHONES 20 jack and its internal amplifier will operate with other headphone impedances, maximum quality will be obtained if headphones with an impedance of approximately 600 ohms are used.

## NOTE

Since the volume 31 control, BASS 22, TREBLE 23, CONTOUR 25, TONE IN 24, etc. affect the level from both the MAIN OUTPUT 13 jacks and the PHONES 20 jack, it is advisable to unplug any set of headphones connected to the PHONES 20 jack whenever they are not in use and you are listening to your speakers. Conversely, if you are listening to your headphones, it is recommended that you turn off your power amplifier to deactivate your loudspeakers, thereby preventing possible interference between the two listening modes or inadvertent damage to either.

## **BALANCE 21**

The BALANCE 21 control permits you to adjust the level of the left channel versus the right channel and vice-versa. Turning the control counterclockwise will reduce the level of the right channel. Turning it clockwise will reduce the level in the left channel. At the maximum counterclockwise position, only the left channel will operate. Conversely, at the maximum clockwise position, only the right channel will operate. In most cases the proper setting of the BALANCE 21 control will be at or near its 12 o'clock position.

To adjust for optimum balance between channels, it is easiest to use a tuner tuned to a station in which the announcer is speaking. This will almost always be a mono signal. Place yourself in your normal listening position and adjust, or have someone adjust, the BALANCE 21 control until the announcer appears to be centered between the two speakers. This method will compensate for almost all the variations within your system, and the room, and is the easiest of all methods to use.

If your system does not include a tuner, the next best way is to select either an analog record or CD, push in the MONO 27 button, place the LISTENING 30 selector on either phono or CD (whichever is being used for this procedure) and adjust the BALANCE 21 control as described above.

Once the correct setting is chosen, it will need to be changed only to compensate for unequal signal levels from an outside music source, such as a cassette, disc, etc.

## **BASS 22**

This control emphasizes the bass frequencies when turned in the clockwise direction and de-emphasizes them when turned counterclockwise in both left and right channels simultaneously. The normal position of the BASS 22 control will be at or near its 12 o'clock position. In many cases, however, it will be useful in compensating for inadequate or over-prominent low bass that is due to poor program sources, inadequate speaker placement, etc. You will very seldom, if ever, need to set this control at its maximum clockwise or counterclockwise position. Please note that the maximum clockwise setting emphasizes extreme low frequencies by a factor of 10 which, when playing music at normal or loud levels, may exceed the power-output capabilities of your amplifier and/or speakers — particularly when playing music of very wide dynamic range.

## **TREBLE 23**

This control emphasizes treble frequencies when turned clockwise. It de-emphasizes them when turned counterclockwise. The control affects both left and right channels simultaneously. Its normal position is at the center, or 12 o'clock, setting. The TREBLE 23 control will be primarily useful in taming musical source material which is strident and/or in adding "sparkle" to older analog recordings or broadcasts of similar material. You may also find it useful to correct for slight speaker deficiencies in their extreme high range or to compensate somewhat for inadequate room acoustics. If your listening room has "dull" acoustics, due to heavy carpeting, upholstered furniture, etc., a small amount of treble boost may achieve better overall balance. Conversely, a "live" room with hard surfaces and sparse furnishings may benefit from a judicious reduction of treble.

### **NOTE**

The tone-control circuitry of the GFP-555II was very carefully designed to provide subtle, but effective, low- and high-frequency equalization without affecting unduly the critical midrange frequencies. Careful circuit damping prevents any action of the BASS 22 or TREBLE 23 controls on the frequency response, or any other parameter of the GFP-555II, when either control is in the normal, centered, 12 o'clock position. Do not expect to hear drastic, non-musical boosts or attenuations of bass and treble usually encountered with less sophisticated tone-control circuits.

## **TONE IN 24**

Pushing in this switch inserts the tone control circuitry (BASS 22 and TREBLE 23 controls) into the circuit path of the GFP-555II. When this switch is in the **out** position, the entire tone control circuitry is completely bypassed and is **not** in the circuitry of the GFP-555II. Please note that in order for the BASS 22 and TREBLE 23 controls to operate, the TONE IN 24 switch must be pushed **in**. The BASS 22 and TREBLE 23 controls are operative only through the MAIN OUTPUT 19.

## NOTE

Whenever the TONE IN 24 switch is pushed **In**, an additional stage of amplification is inserted into the circuitry of the GFP-555II. As a result, the normally non-inverted signal at the MAIN OUTPUT 13 will be inverted in polarity. In other words, if there is a signal with positive-going polarity at the MAIN OUTPUT 13 jacks when the TONE IN 24 switch is in the **out** position, the signal will be inverted (to negative-going polarity) whenever the TONE IN 24 switch is pushed **In**. See MAIN OUTPUT 13 above.

### CONTOUR 25

The CONTOUR circuit in the GFP-555II differs markedly from conventional loudness compensation circuits. Recent studies show that conventional circuits overcompensate for natural low- and high-frequency hearing reduction at low signal levels. The studies of Robinson and Dadson of Harvard University have provided guidelines for a newer and more accurate curve for loudness compensation. In our judgement, a subtle boost of low frequencies (in the 20-100Hz range) and no boost at high frequencies, provides the ideal musical balance for listening at low to moderate levels. The effects of the circuit gradually diminish as the volume level is increased (that is, when the volume 31 control is turned clockwise). Pushing **In** the CONTOUR 25 switch activates this function. Whenever the CONTOUR 25 switch is in the **out** position, the CONTOUR circuit will be disconnected from the circuitry of the GFP-555II.

### LOW FILTER 26

Pushing **In** this switch engages an infrasonic filter to roll off the extreme low frequencies. This switch will be particularly useful when playing older analog recordings, which contain "rumble", or if your turntable is prone to acoustic feedback or rumble as well. The LOW FILTER 26 is meant to be used whenever there is infrasonic energy in the music signal which is either unrelated to the musical material or is disturbing in one way or another. The infrasonic filter will also be extremely useful when playing back warped records in which the warp may generate very-low-frequency energy which could drive your loudspeakers or amplifier into non-linear operating regions. Whenever the LOW FILTER 26 is **out**, the infrasonic filter is removed from the circuitry of the GFP-555II. Please note that the LOW FILTER 26 circuit is operative only through the MAIN OUTPUT 13.

### MONO 27

Pushing **In** this switch mixes the left- and right-channel signals. This combined signal is then fed to both BYPASS OUTPUT 12 and MAIN OUTPUT 13 jacks. The mono switch does not insert switch contacts in series with the signal path but simply parallels the left and right channels. The MONO 27 switch is useful in reducing FM noise and distortion on weak stations, or when playing older analog mono recordings, or in checking relative phasing of your loudspeakers. It is also useful when setting channel balance of your loudspeakers using the BALANCE 21 control.

### PROCESSOR IN 28

Pushing **In** this switch connects the SIGNAL PROCESSOR IN 10 and SIGNAL PROCESSOR OUT 11 jacks on the rear panel of the GFP-555II. Please refer to the section SIGNAL PROCESSOR IN 10 / SIGNAL PROCESSOR OUT 11 above for a complete explanation of the function of this circuit. Please note that whenever the PROCESSOR IN 28 switch is in the **out** position, whatever processor is connected to the SIGNAL PROCESSOR IN 10 and SIGNAL PROCESSOR OUT 11 jacks will be **completely** disconnected from the circuit to prevent any possible degradation of the signal being amplified by the GFP-555II.

### RECORDING 29

This rotary selector switch permits you to choose any input connected to the GFP-555II and feed it directly to the TAPE 1 OUT 6 and TAPE 2 OUT 8 jacks on the rear panel of the GFP-555II for recording the selected input. With the GFP-555II selector system, it is possible to record one source (say, CD 3 or PHONO 2) while listening to a different source such as an FM tuner or DAT. Please refer to the sections TAPE 1 OUT 6 and TAPE 2 OUT 8 above for the proper use of the RECORDING 29 selector in conjunction with these outputs.

Neither the volume 31 control nor any of the other controls on the front panel of the GFP-555II, including the PROCESSOR IN 28 switch, affect the output at the TAPE 1 OUT 6 or TAPE 2 OUT 8 jacks.

### LISTENING 30

This rotary selector lets you choose any input connected to the GFP-555II and feed it, through the circuitry of the GFP-555II, to both the BYPASS OUTPUT 12 and MAIN OUTPUT 13 jacks (as well as to the PHONES 20 jack) and, then, through your amplifier and loudspeakers. The LISTENING 30 selector operates independently from the RECORDING 29 selector (above); therefore, you can listen to one source while recording another, different source. All the controls on the front panel of the GFP-555II will affect the signal present at the MAIN OUTPUT 13 jacks. The BYPASS OUTPUT 12 jacks will be affected only by the BALANCE 21, CONTOUR 25, MONO 27, PROCESSOR IN 28 and the volume 31 control.

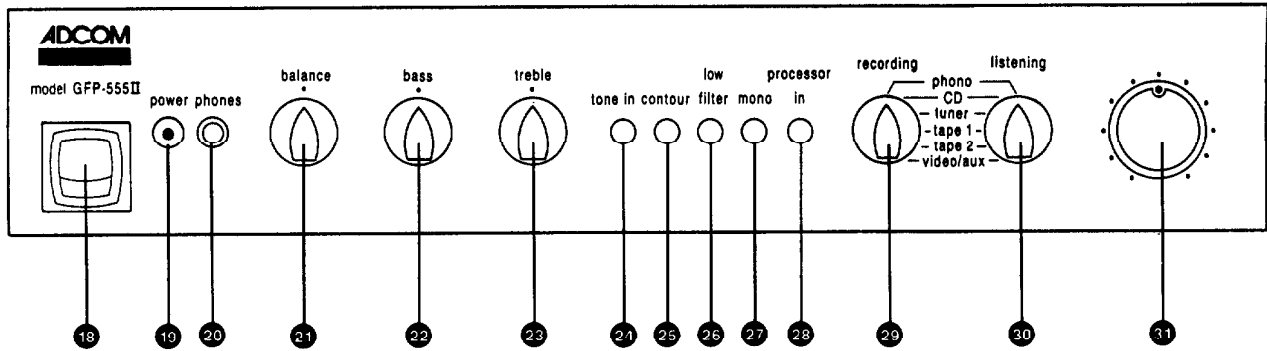

GFP-555II Front Panel Diagram

## VOLUME 31

This rotary control sets the level at the BYPASS OUTPUT 12, MAIN OUTPUT 13, and the PHONES 20 jacks and, consequently, the level heard through the headphones, amplifier and speakers. Turning this control clockwise will raise the level of the signal chosen via the LISTENING 30 selector. Turning the control counterclockwise will reduce the level of the signal. Normally, when used with standard amplifiers and speakers having medium-to-low sensitivities, the position of this control will be at its normal 12:30 to 1:30 o'clock position. There are many factors which will affect the position of the volume 31 control for any given listening level. Among these are: the specific sensitivity of the power amplifier for maximum output; the sensitivity (or "efficiency") of the speakers being used; the size of the room in which the speakers are located; the output levels of the sources being used and plugged into the GFP-555II (cassette machine, tape recorder, CD player, etc.); the modulation level of the station being received by your tuner; etc. The position of the volume 31 control is a relative indication to permit you to return to a similar level setting again and again. It is not an absolute indication of how much power the amplifier is delivering to the speakers or "how powerful" a system is. It is quite possible, with different component systems, to have the same power output from an amplifier, and sound level from the speakers, but with different volume 31 control settings of the GFP-555II.

It is also quite common to have to set the volume 31 control to a different position, when switching from one source (say, CD) to another (such as a cassette machine), to achieve the same, or approximate, volume level from the loudspeakers. Similarly, different FM and AM stations received by your tuner may require adjustment of the volume 31 control depending on the amount of audio "limiting" and "compression" used by the particular station and/or the type of music it broadcasts.

## NOTE

For the reasons described above, it is good practice to lower the volume 31 control before changing the LISTENING 30 selector to another input. It is also advisable to unplug headphones from the PHONES 20 jack when using your loudspeakers, or turn off your power amplifier through its on/off switch when listening to headphones. See PHONES 20 above.

The design of the GFP-555II makes it usable with the gamut of power amplifiers presently available, as well as with all loudspeakers presently in use. The volume 31 control was designed to be fully operable throughout its complete rotation.

## CARING FOR YOUR GFP-555II

Great care has been taken by ADCOM to assure that your preamplifier is as flawless in appearance as it is electronically. The front panel is a heavy-gauge, high-grade, anodized-aluminum extrusion, bead-blasted for durability. The bottom cover, chassis, top cover and rear panel are of heavy-gauge steel, both painted and baked. If the front panel, top or sides should become dusty or fingerprinted, they can be cleaned with a soft, lintless cloth, slightly dampened with a very mild detergent solution.

## NOTE

**DO NOT SPRAY OR USE LIQUIDS OF ANY KIND ON THE SURFACES OF THE GFP-555II.**

## **SERVICING**

ADCOM has a Technical Service Department to answer questions pertinent to the installation and operation of your unit. In the event of difficulty, please contact us for prompt advice. If your problem cannot be resolved through our combined efforts, we may refer you to an authorized repair agency, or authorize return of the unit to the factory. To aid us in directing you to a convenient service station, it would be helpful if you indicate which major city is accessible to your home.

Please address mail inquiries to:  
ADCOM Service Corp.  
11 Elkins Road  
East Brunswick, New Jersey 08816

For telephone inquiries call:  
Monday through Friday  
9AM to 4PM Eastern Time  
(201) 390-1130

For fax inquiries: (201) 390-9152; please include a return fax number for the reply.

When calling or writing about your GFP-555II, be sure to note and refer to its model and serial numbers as well as the date of purchase and the dealer from whom it was purchased. In the event that the unit must be returned to the factory for service, you will be instructed as to the proper procedure when you call or write for a Return Authorization.

**UNDER NO CIRCUMSTANCES SHOULD YOUR UNIT BE SHIPPED TO THE FACTORY WITHOUT OBTAINING PRIOR AUTHORIZATION, OR PACKED IN OTHER THAN ITS ORIGINAL CARTON AND FILLERS.**

If the original shipping carton and its fillers have been lost, discarded, or damaged, a duplicate carton may be obtained from our Service Department for a nominal charge. Inquire as to the procedure when requesting a Return Authorization.

Always ship PREPAID via United Parcel Service (UPS) or other approved carrier. **DO NOT SHIP VIA PARCEL POST**, since the packing was not designed to withstand rough Parcel Post handling. **FREIGHT COLLECT SHIPMENTS CANNOT BE ACCEPTED.**

**ADCOM**  
11 Elkins Road  
East Brunswick, NJ 08816  
Telephone (201) 390-1130  
Fax (201) 390-9152

## SPECIFICATIONS

Output Impedance	
Bypass Output .....	100 ohms
Main Output .....	100 ohms
Tape Out .....	475 ohms
Output Level (Rated)	
Bypass Output .....	2.0V
Main Output .....	2.0V
Output Level (Maximum)	
Bypass Output .....	10.0V
Main Output .....	10.0V
Frequency Response (+0.5dB)	
High Level .....	.5Hz-85kHz
Phono .....	.5Hz-60kHz
THD + Noise (@ Rated Output, 20Hz-20kHz)	
High Level .....	0.003%
Phono .....	0.02%
IMD (SMPTE, @ Rated Output)	
High Level .....	0.004%
Phono .....	0.006%
Signal-to-Noise (@ Rated Output, "A" Weighted)	
High Level .....	≥100dB
Phono .....	≥90dB
Input Impedance	
High Level .....	22,000 ohms
Phono .....	47,000 ohms/100pF
Input Sensitivity (@ Rated Output)	
High Level .....	200mV
Phono .....	2.3mV
RIAA Accuracy (20Hz-20kHz) .....	±0.1dB
Tape Out THD + Noise (@ 2.0V, 20Hz-20kHz) .....	0.003%
Tape Out IMD (SMPTE) @ 2.0V .....	0.002%
Tone Controls	
Bass (20Hz) .....	±10dB
Treble (20kHz) .....	±9dB
Loudness (Volume Control @ 9:00 o'clock)	
100Hz .....	+5dB
20Hz .....	+10dB
Crosstalk (1kHz) .....	-95dB
Separation (1kHz, @ Rated Output) .....	≥75dB
Low Filter (20Hz) .....	-3.5dB

## GENERAL

Power (available in 220V or 240V on special order) .....	120VAC/50-60Hz
Power Consumption .....	10 watts max.
Chassis Dimensions .....	17" (432mm)x11-3/8" (289mm)x3" (76mm)
Maximum Dimensions .....	17" (432mm)x12-9/16" (319mm)x3-1/4" (83mm)
Weight .....	11.5 lbs. (5.2 kg)
Weight, Packed .....	15 lbs. (6.8 kg)

Specifications subject to change  
without prior notice.

**ADCOM**  
11 Elkins Road  
East Brunswick, NJ 08816  
Telephone (201) 390-1130  
Fax (201) 390-9152

CVC0910